

## 1 Features

- Designed for GSM applications [800/900/1800/1900 MHz]
- Intended for Snap-In mounting
- Supplied in trays

## 2 Description

The Flavus antenna is intended for use with all GSM applications. The antenna is a quarterwave type. The antenna uses plastic snap ins to attach to the PCB, no need for soldering.

## 3 Application

- GSM modules
- Cell phones
- Vehicle tracking



## Contents

1 Features	1
2 Description	1
3 Application	1
4 Model name	3
5 General data	3
6 Electrical characteristics	3
7 Electrical performance	4
7.1 Voltage Standing Wave Ratio	4
7.2 Radiation patterns	4
8 Antenna Dimensions	5
9 Antenna Footprint	5
10 Electrical interface	6
10.1 Transmission line and matching	6
10.2 Test board dimensions	6
10.3 Test board matching	7
11 Reliability	7
11.1 Temperature and Humidity	7
11.2 Mechanical	7
11.3 Miscellaneous	8
11.4 Judgement standard	8
12 Hazardous Material Regulation Conformance	8
13 Application example	9
14 Packaging	10
14.1 Shelf storage recommendation	10
14.2 Packaging characteristics	10
14.3 Tray dimension	10
14.4 Box dimension	10
14.5 Label information	10

### 4 Model name

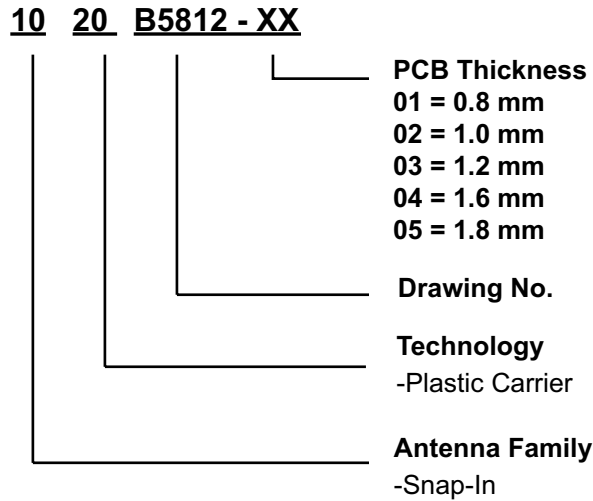

### 5 General data

<b>Product Name</b>	Flavus GSM
<b>Article No.</b>	1020B5812-01..05
<b>Frequency</b>	880-960 MHz, 1710-1990 MHz
<b>Polarization</b>	Linear
<b>Operating temperature</b>	-40 to + 85 degC
<b>Impedance</b>	50 Ohm
<b>Weight</b>	0.6 gram
<b>Antenna type</b>	Snap-in

### 6 Electrical characteristics

	Characteristics			Conditions*
	GSM	DCS	PCS	
<b>Efficiency</b>	> 65%	> 68 %	> 77%	Measured in 3D chamber ( near field)
<b>VSWR</b>	< 1:2.3	< 1:2.7	< 1:1.9	Measured in Network Analyzer

\*Note all data provided in this table are based on the Antenova reference board

## 7 Electrical performance

### 7.1 Voltage Standing Wave Ratio

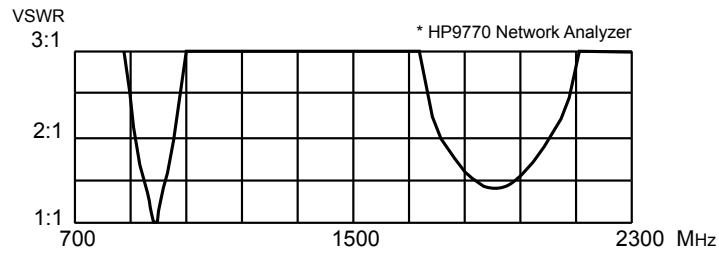

### 7.2 Radiation patterns

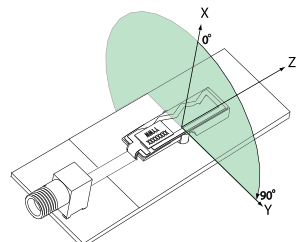

XZ- Plane

— 810(MHz)  
— 920(MHz)  
— 960(MHz)

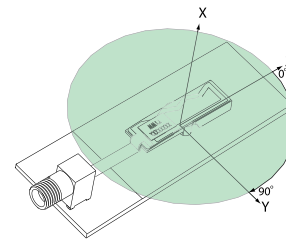

YZ- Plane

— 810(MHz)  
— 920(MHz)  
— 960(MHz)

GSM

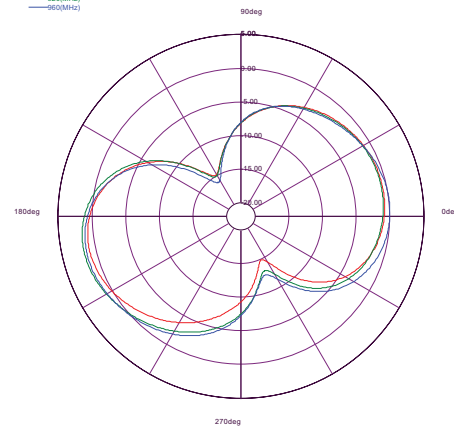
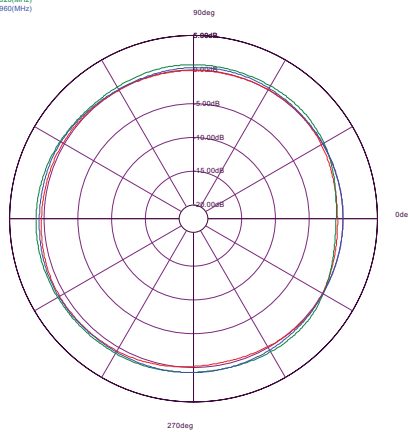

DCS/PCS

— 1710(MHz)  
— 1750(MHz)  
— 1850(MHz)  
— 1900(MHz)  
— 1920(MHz)  
— 1950(MHz)

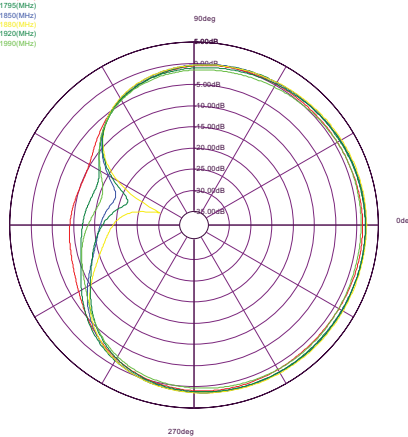

— 1710(MHz)  
— 1750(MHz)  
— 1850(MHz)  
— 1900(MHz)  
— 1920(MHz)  
— 1950(MHz)

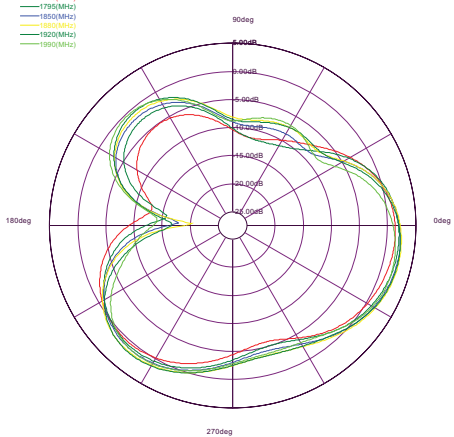

### 8 Antenna Dimensions

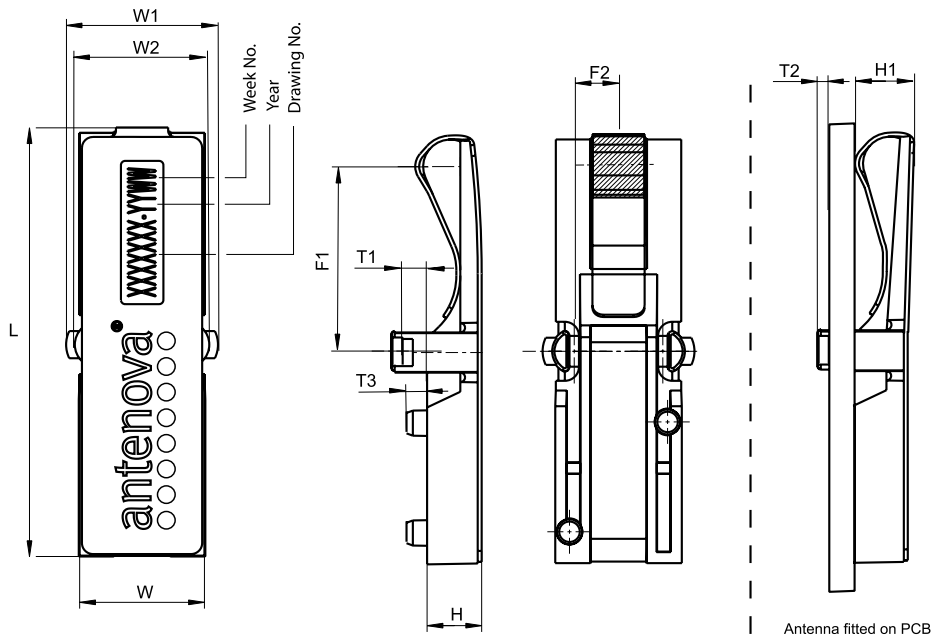

L	W	W1	W2	H	H1	F1	F2	T1	T2	T3
Length	Width	Width	Width	Height	Height	Feed	Feed	PCB		
27.3 ±0.2	7.9 ±0.2	9.6±0.2	8.5±0.2	3.45±0.1	3.85±0.1	11.85±0.2	2.8±0.1	T1±0.05	1.35±0.2	1.3±0.1

Dimensions in millimeters

### 9 Antenna Footprint

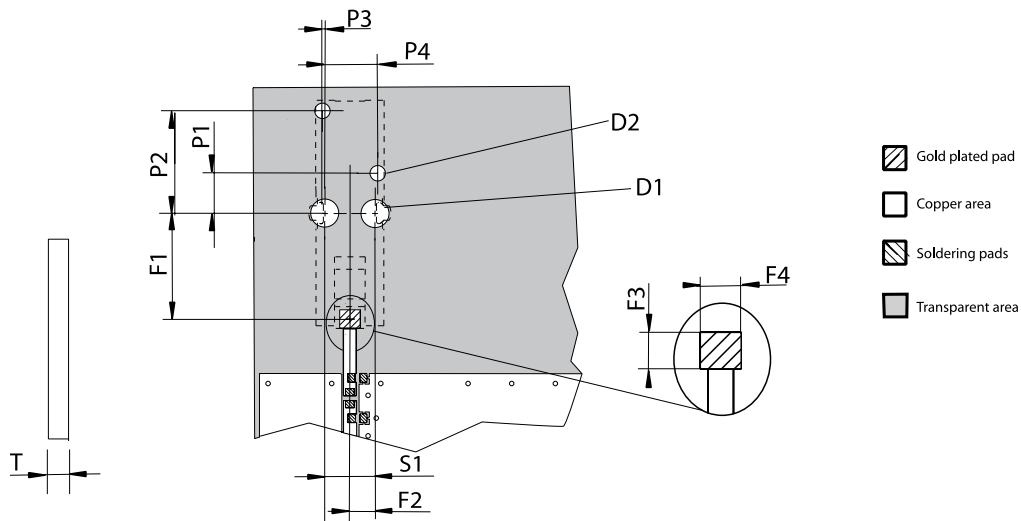

F1	F2	F3	F4	S1	P1	P2	P3	P4	D1	D2	T*
Feed	Feed	Feed	Feed	Snap-In	Position	Position	Position	Position	Diameter	Diameter	PCB
11.85±0.1	2.8±0.1	2±0.05	2.25±0.05	5.6±0.1	4.5±0.1	11.5±0.1	0.3±0.1	5.9±0.1	3.05±0.1	1.75±0.1	0.8, 1.0, 1.2, 1.6, 1.8

Dimensions in millimeters

## 10 Electrical interface

### 10.1 Transmission line and matching

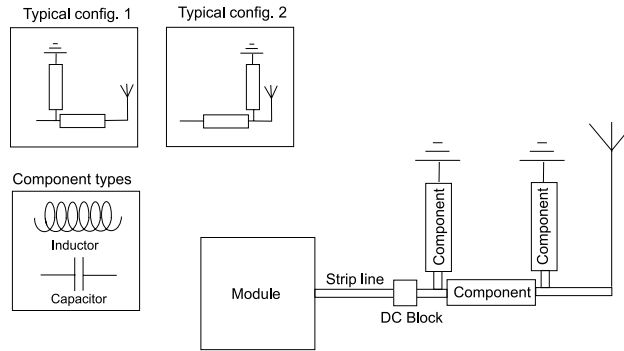

The matching network has to be individually designed using one, two or three components.

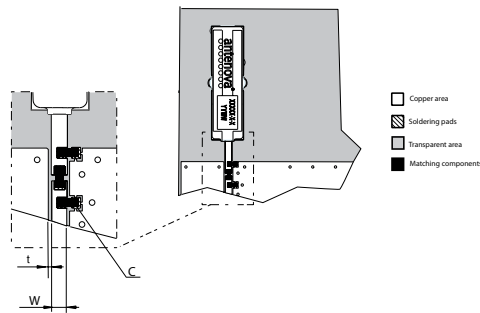

$t, w$  = Unique dimensioning according to your PCB \*

$C$  = Inductor and capacitor values according to your specific device\*

\* Antenova provides this service upon request

### 10.2 Test board dimensions

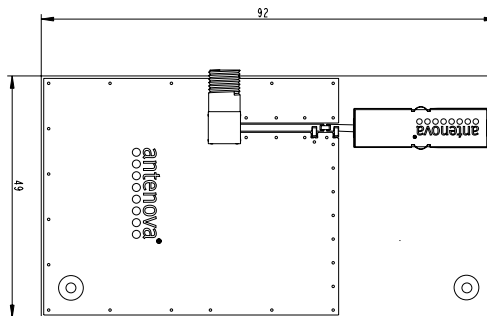

The testboard is designed for evaluation purposes for Flavus GSM antenna. The card has the same size as a typical PCMCIA card and is fitted with an SMA connector.

### 10.3 Test board matching

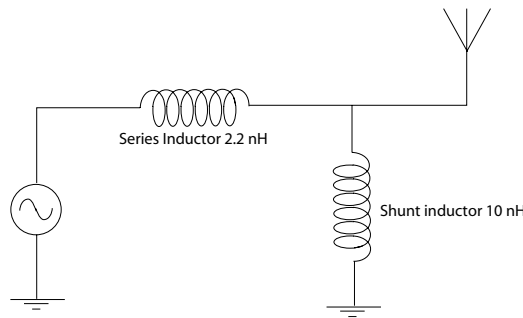

The testboard is matched with above specified component.

**Note! The component value(s) will vary depending on size of PCB, surrounding components etc.**

## 11 Reliability

### 11.1 Temperature and Humidity

Item	Standard	Low	High	Duration
Operating temperature	EN/IEC 60068-2-2, Test Bd: Dry heat	-30 degC	+90 degC	-
Temperature cycling	EN/IEC 60068-2-14, Test Na: Change of temperature	-30 degC	+90 degC	100cycles / 10min
Storage life Humidity	EN/IEC 60068-2-1, Test Ca: Damp heat	+40 degC / 93% RH		96 h
Storage life Low temperature	EN/IEC 60068-2-1, Test Ad: Cold	-25 degC	-	200 h
Storage life High temperature	EN/IEC 60068-2-2, Test Bb: Dry heat	-	+ 90 degC	1000 h

### 11.2 Mechanical

Item	Standard	Specification	Duration
Contact force		Antenna is mounted on reference board. and a pressure gauge is applied to antenna contact.	
Drop test		Dummy weight: 150g Height: 170cm	One drop at each side, total drops: 6
Vibration	EN/IEC 60068-2-6, Test Fc (sinusoidal)	Acceleration spectral density:10-1000Hz Acceleration: 20m/s <sup>2</sup> Number of axes: 3 mutually perpendicular	5 cycles per axis

### 11.3 Miscellaneous

Item	Standard	Specification	Duration
Contact pad Corrosion	ASTM B117	SO2 Concentration: 25 ppm Temperature : 25 Deg C RH: 93%	96 hours

### 11.4 Judgement standard

The judgement of the above tests should be made as follows:

1. Visual inspection - Normal appearance with no obvious deformation
2. Electrical inspection - The antenna satisfies the VSWR specification throughout the GSM band
3. Mechanical inspection - Acceptable contact force min. 0.5 N

## 12 Hazardous Material Regulation Conformance

Cadmium and cadmium compound.	Lead and lead compound
Organic brominated compound (PBB, PBDE)	Mercury and mercury compound
Polychlorinated biphenyl (PCB)	Sexivalent chrome compound
Polychlorinated naphthalene (PCN)	Chlorinated paraffin (CP)
Organic tin compound	Mirex
Asbestos	Formaldehyde
Azo compound	Tetra-bromo-bisphenol-A-bis (TBBP-A-bis)

## 13 Application example

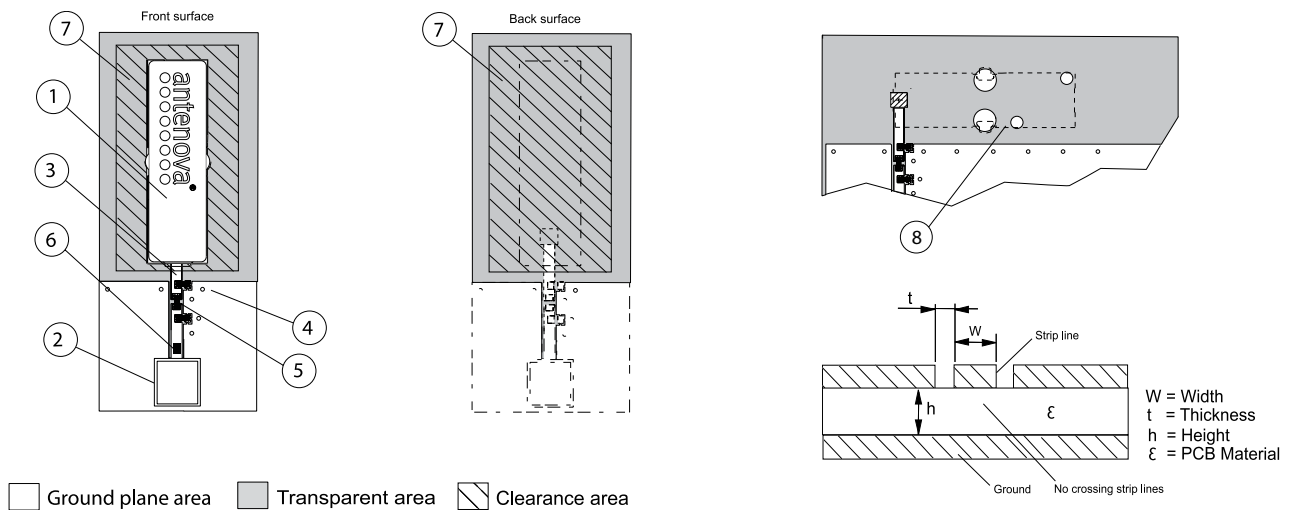

Fig. 1

### 1. Placement of antenna

The antenna shall preferably be placed at the edge of the PCB oriented as above. Other placements and orientations and size of groundplanes are possible, but will affect the performance. Avoid active components near the antenna.

### 2. Placement of GSM module or radio

To avoid losses the module shall be placed as close to the antenna as possible.

### 3. Strip line

The strip line must be dimensioned according to your specific PCB. ( see Fig 1). No crossing strip lines are allowed between the strip line and its ground plane.

### 4. Via connections

To avoid spurious effects, via connections must be made to analogue ground.

### 5. Component matching

Component values are depending on antenna placement, PCB dimensions and location of other components.

### 6. DC Block

Might be needed depending on RF Module configuration.

### 7. Clearance area

Avoid components and parts close to the antenna.

### 8. Alternate positioning

The Flavus GSM antenna can placed horizontally to the groundplane, but this position is less favourable than the recommended vertical placement, and will cause a decrease in performance.

**Note ! Incorrect implementation of the antenna will affect the performance.  
Contact Antenova for implementation services.**

## 14 Packaging

### 14.1 Shelf storage recommendation

<b>Temperature</b>	-10 to +40 degree C
<b>Humidity</b>	Less than 75% RH
<b>Shelf Life</b>	12 Months
<b>Storage place</b>	Away from corrosive gas and direct sunlight

### 14.2 Packaging characteristics

Quantity	Number of trays	Tray quantity
840 pcs / box	6 / box	140 pcs

### 14.3 Tray dimension

Material: Anti static plastic tray  
 Width [mm] W: 290  
 Breadth [mm] B: 390  
 Height [mm] H: 14

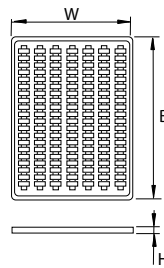

### 14.4 Box dimension

Material: Paper  
 Width [mm] W: 296  
 Breadth [mm] B: 396  
 Height [mm] H: 75

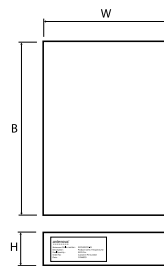

### 14.5 Label information

Antenna Article number :	XXXXXXXX-XX
Description :	Product name, Frequency Hz
Reel Quantity :	XXXX Pcs.
Order No:	Customer PO number
Date:	YYMMDD



[www.antenova.com](http://www.antenova.com)

### Corporate Headquarters

#### Antenova Ltd.

Far Field House  
Albert Road  
Stow-cum-Quy  
Cambridge, CB25 9AR  
UK

**Tel:** +44 (0) 1223 810600  
**Fax:** +44 (0) 1223 810650  
**Email:** [sales@antenova.com](mailto:sales@antenova.com)

### Asia Headquarters

#### Antenova Asia Ltd.

4F, No. 324, Nei-Hu Dist.  
Nei-Hu Sec. 1  
Taipei, Taiwan  
ROC

**Tel:** +886 (0) 2 8797 8630  
**Fax:** +886 (0) 2 8797 6890  
**Email:** [sales@antenova.com](mailto:sales@antenova.com)



Certificate No: 4598/04