

**PICDEM™ CAN-LIN 2**  
**Development Kit**  
**for 28/40-pin Devices**  
**User's Guide**

---

**Note the following details of the code protection feature on Microchip devices:**

- Microchip products meet the specification contained in their particular Microchip Data Sheet.
- Microchip believes that its family of products is one of the most secure families of its kind on the market today, when used in the intended manner and under normal conditions.
- There are dishonest and possibly illegal methods used to breach the code protection feature. All of these methods, to our knowledge, require using the Microchip products in a manner outside the operating specifications contained in Microchip's Data Sheets. Most likely, the person doing so is engaged in theft of intellectual property.
- Microchip is willing to work with the customer who is concerned about the integrity of their code.
- Neither Microchip nor any other semiconductor manufacturer can guarantee the security of their code. Code protection does not mean that we are guaranteeing the product as "unbreakable."

Code protection is constantly evolving. We at Microchip are committed to continuously improving the code protection features of our products. Attempts to break microchip's code protection feature may be a violation of the Digital Millennium Copyright Act. If such acts allow unauthorized access to your software or other copyrighted work, you may have a right to sue for relief under that Act.

---

Information contained in this publication regarding device applications and the like is intended through suggestion only and may be superseded by updates. It is your responsibility to ensure that your application meets with your specifications. No representation or warranty is given and no liability is assumed by Microchip Technology Incorporated with respect to the accuracy or use of such information, or infringement of patents or other intellectual property rights arising from such use or otherwise. Use of Microchip's products as critical components in life support systems is not authorized except with express written approval by Microchip. No licenses are conveyed, implicitly or otherwise, under any intellectual property rights.

**Trademarks**

The Microchip name and logo, the Microchip logo, KEELOQ, MPLAB, PIC, PICmicro, PICSTART, PRO MATE and PowerSmart are registered trademarks of Microchip Technology Incorporated in the U.S.A. and other countries.

FilterLab, microID, MXDEV, MXLAB, PICMASTER, SEEVAL and The Embedded Control Solutions Company are registered trademarks of Microchip Technology Incorporated in the U.S.A.

Accuron, Application Maestro, dsPIC, dsPICDEM, dsPICDEM.net, ECONOMONITOR, FanSense, FlexROM, fuzzyLAB, In-Circuit Serial Programming, ICSP, ICEPIC, microPort, Migratable Memory, MPASM, MPLIB, MPLINK, MPSIM, PICC, PICkit, PICDEM, PICDEM.net, PowerCal, PowerInfo, PowerMate, PowerTool, rLAB, rPIC, Select Mode, SmartSensor, SmartShunt, SmartTel and Total Endurance are trademarks of Microchip Technology Incorporated in the U.S.A. and other countries

Serialized Quick Turn Programming (SQTP) is a service mark of Microchip Technology Incorporated in the U.S.A.

All other trademarks mentioned herein are property of their respective companies.

© 2003, Microchip Technology Incorporated, Printed in the U.S.A., All Rights Reserved.

 Printed on recycled paper.

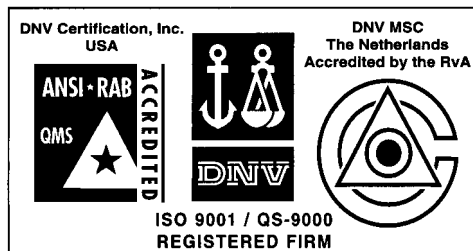

*Microchip received QS-9000 quality system certification for its worldwide headquarters, design and wafer fabrication facilities in Chandler and Tempe, Arizona in July 1999 and Mountain View, California in March 2002. The Company's quality system processes and procedures are QS-9000 compliant for its PICmicro® 8-bit MCUs, KEELOQ® code hopping devices, Serial EEPROMs, microperipherals, non-volatile memory and analog products. In addition, Microchip's quality system for the design and manufacture of development systems is ISO 9001 certified.*

---



---

**Table of Contents**

---



---

<b>Preface.....</b>	<b>1</b>
<b>Chapter 1. Introduction to the PICDEM™ CAN-LIN 2 Board</b>	
1.1 Introduction .....	7
1.2 Highlights .....	7
1.3 PICDEM CAN-LIN 2 Development Kit Contents .....	7
1.4 Overview of the PICDEM CAN-LIN 2 Board .....	8
1.5 PICDEM CAN-LIN 2 Board Features .....	9
1.6 CANKing Host Software .....	12
<b>Chapter 2. Getting Started with the PICDEM™ CAN-LIN 2 Board</b>	
2.1 Highlights .....	13
2.2 Host Computer Requirements .....	13
2.3 Using the PICDEM CAN-LIN 2 Board for the First Time .....	13
2.4 Checking the Board in Evaluation Mode .....	19
<b>Chapter 3. Getting Started with the CANKing Software</b>	
3.1 Highlights .....	21
3.2 Software Overview .....	21
3.3 Starting the Program .....	21
3.4 Introduction to the Templates .....	22
3.5 The Main Menu .....	22
3.6 The Output Window .....	23
3.7 Customizing Projects .....	24
<b>Chapter 4. Using the CANKing Templates</b>	
4.1 Highlights .....	25
4.2 PIC Register View Template .....	25
4.3 The Basic Template .....	30
4.4 PIC18+CAN Evaluation Board Template .....	35
4.5 Template-Specific Variations in the Main Menu .....	40
<b>Chapter 5. Reconfiguring the PICDEM™ CAN-LIN 2 Hardware</b>	
5.1 Highlights .....	41
5.2 Node Configurations .....	41
5.3 Oscillator Configurations .....	42
5.4 Jumper Settings .....	42
5.5 Restoring the PICDEM CAN-LIN 2 Firmware .....	43

# PICDEM™ CAN-LIN 2 User's Guide

---

---

## Chapter 6. Troubleshooting

6.1 Highlights .....	45
6.2 Common Problems .....	45

## Appendix A. PICDEM™ CAN-LIN 2 Board Technical Information

A.1 Highlights .....	47
A.2 Block Diagram .....	47
A.3 PICDEM CAN-LIN 2 Board Schematics .....	48

## Appendix B. FAQs on Configuring the PIC18FXX8

B.1 Highlights .....	55
B.2 FAQs .....	55

## Appendix C. PICDEM™ CAN-LIN 2 Software CD

C.1 Highlights .....	57
C.2 What's on the CD .....	57

<b>Index.....</b>	<b>59</b>
-------------------	-----------

<b>Worldwide Sales and Service.....</b>	<b>62</b>
---	-----------

## Preface

---

---

### INTRODUCTION

This chapter contains general information about this manual and contacting customer support.

### HIGHLIGHTS

Items discussed in this chapter are:

- About this Guide
- Warranty Registration
- Recommended Reading
- Troubleshooting
- Microchip On-Line Support
- Customer Change Notification Service
- Customer Support

### ABOUT THIS GUIDE

#### Document Layout

This document describes how to use the PICDEM™ CAN-LIN 2 Development Board as a development system for the PICmicro® PIC18FXX8 microcontrollers. The manual layout is as follows:

- **Chapter 1: Introduction to the PICDEM™ CAN-LIN 2 Board** – What the PICDEM CAN-LIN 2 Board is, what makes it a desirable development tool and what features are available.
- **Chapter 2: Getting Started with the PICDEM™ CAN-LIN 2 Board** – Describes how to connect and begin to use the PICDEM CAN-LIN 2 board.
- **Chapter 3: Getting Started with the CANKing Software** – Gives a brief overview of the CANKing host software and the concept of the pre-defined templates.
- **Chapter 4: Using the CANKing Templates** – Provides a more detailed description of the individual templates and how to use them.
- **Chapter 5: Reconfiguring the PICDEM™ CAN-LIN 2 Hardware** – Describes various multi-node configurations of the board, and how to customize certain features.
- **Chapter 6: Troubleshooting** – Provides information on solving common problems.

- **Appendix A: PICDEM™ CAN-LIN 2 Technical Information** – Provides the block diagram and detailed schematics of the PICDEM CAN-LIN 2 board.
- **Appendix B: FAQs on Configuring the PIC18FXX8** – Provides a list of the most commonly encountered issues when programming PIC18FXX8 microcontrollers, as well some solutions.
- **Appendix C: PICDEM™ CAN-LIN 2 Software CD** – Provides a summary of the software on the accompanying CD-ROM.
- **Index** – Cross-reference listing of terms, features and sections of this document.
- **Worldwide Sales and Service** – gives the address, telephone and fax number for Microchip Technology Inc. sales and service locations throughout the world.

## Conventions Used in This Guide

This manual uses the following documentation conventions:

**Table: Documentation Conventions**

Description	Represents	Examples
<b>Code (Courier font):</b>		
Plain characters	Sample code Filenames and paths	#define START c:\autoexec.bat
Angle brackets: < >	Variables	<label>, <exp>
Square brackets [ ]	Optional arguments	MPASMWIN [main.asm]
Curly brackets and pipe character: {   }	Choice of mutually exclusive arguments; An OR selection	errorlevel {0 1}
Lower case characters in quotes	Type of data	"filename"
Ellipses...	Used to imply (but not show) additional text that is not relevant to the example	list ["list_option...", "list_option"]
0xnnn	A hexadecimal number where n is a hexadecimal digit	0xFFFF, 0x007A
Italic characters	A variable argument; it can be either a type of data (in lower case characters) or a specific example (in upper case characters).	char isascii (char, ch);
<b>Interface (Arial font):</b>		
Underlined, italic text with right arrow	A menu selection from the menu bar	<u>File &gt; Save</u>
Bold characters	A window or dialog button to click	<b>OK, Cancel</b>
Characters in angle brackets < >	A key on the keyboard	<Tab>, <Ctrl-C>
<b>Documents (Arial font):</b>		
Italic characters	Referenced books	<i>MPLAB® IDE User's Guide</i>

## Documentation Updates

All documentation becomes dated, and this user's guide is no exception. Since MPLAB® IDE, MPLAB C1X and other Microchip tools are constantly evolving to meet customer needs, some actual dialogs and/or tool descriptions may differ from those in this document. Please refer to our web site to obtain the latest documentation available.

# Introduction to the PICDEM™ CAN-LIN 2 Board

---

## Documentation Numbering Conventions

Documents are numbered with a “DS” number. The number is located on the bottom of each page, in front of the page number. The numbering convention for the DS Number is: DSXXXXXA,

where:

XXXXX = The document number.

A = The revision level of the document.

## WARRANTY REGISTRATION

Please complete the enclosed Warranty Registration Card and mail it promptly. Sending in your Warranty Registration Card entitles you to receive new product updates. Interim software releases are available at the Microchip web site.

## RECOMMENDED READING

This user’s guide describes how to use the PICDEM CAN-LIN 2 Development Kit. The data sheets contain current information on programming the specific microcontroller devices.

### **MPLAB® IDE User’s Guide (DS51025)**

Comprehensive guide that describes installation and features of Microchip’s MPLAB Integrated Development Environment (IDE), as well as the editor and simulator functions in the MPLAB IDE environment.

### **MPASM™ User’s Guide with MPLINK™ and MPLIB™ (DS33014)**

This user’s guide describes how to use the Microchip PICmicro MCU MPASM assembler, the MPLINK object linker and the MPLIB object librarian.

### **Technical Library CD-ROM (DS00161)**

This CD-ROM contains comprehensive application notes, data sheets and technical briefs for all Microchip products. To obtain this CD-ROM, contact the nearest Microchip Sales and Service location (see back page) or download individual data sheet files from the Microchip web site (<http://www.microchip.com>).

### **Embedded Control Handbook (DS00711)**

This handbook consists of several documents that contain a wealth of information about microcontroller applications. To obtain these documents, contact the nearest Microchip Sales and Service location (see back page).

The application notes described in these manuals are also obtainable from Microchip Sales and Service locations or from the Microchip web site (<http://www.microchip.com>).

### **PICmicro® Mid-Range MCU Family Reference Manual (DS33023) and PICmicro® 18C MCU Family Reference Manual (DS39500)**

These manuals explain the general details and operation of the mid-range and advanced MCU family architecture and peripheral modules. They are designed to complement the device data sheets.

### **Microsoft® Windows® Manuals**

This manual assumes that users are familiar with the Microsoft Windows operating system. Many excellent references exist for this software program, and should be consulted for general operation of Windows.

## TROUBLESHOOTING

See Chapter 6 for information on common problems.

## MICROCHIP ON-LINE SUPPORT

Microchip provides on-line support on the Microchip web site at:

**<http://www.microchip.com>**

A file transfer site is also available by using an FTP service connecting to:

**<ftp://ftp.microchip.com>**

The web site and file transfer site provide a variety of services. Users may download files for the latest development tools, data sheets, application notes, user' guides, articles and sample programs. A variety of Microchip specific business information is also available, including listings of Microchip sales offices and distributors. Other information available on the web site includes:

- Latest Microchip press releases
- Technical support section with FAQs
- Design tips
- Device errata
- Job postings
- Microchip consultant program member listing
- Links to other useful web sites related to Microchip products
- Conferences for products, development systems, technical information and more
- Listing of seminars and events

## CUSTOMER CHANGE NOTIFICATION SERVICE

Microchip started the customer notification service to help customers stay current on Microchip products with the least amount of effort. Once you subscribe, you will receive email notification whenever we change, update, revise or have errata related to your specified product family or development tool of interest.

Go to the Microchip web site ([www.microchip.com](http://www.microchip.com)) and click on Customer Change Notification. Follow the instructions to register.

The Development Systems product group categories are:

- Compilers
- Emulators
- In-Circuit Debuggers
- MPLAB IDE
- Programmers

Here is a description of these categories:

**Compilers** – The latest information on Microchip C compilers and other language tools. These include the MPLAB C17, MPLAB C18 and MPLAB C30 C Compilers; MPASM and MPLAB ASM30 assemblers; MPLINK and MPLAB LINK30 linkers; and MPLIB and MPLAB LIB30 librarians.

**Emulators** – The latest information on Microchip in-circuit emulators. This includes the MPLAB ICE 2000.

**In-Circuit Debuggers** – The latest information on Microchip in-circuit debuggers. These include the MPLAB ICD and MPLAB ICD 2.

# Introduction to the PICDEM™ CAN-LIN 2 Board

---

**MPLAB** – The latest information on Microchip MPLAB IDE, the Windows Integrated Development Environment for development systems tools. This list is focused on the MPLAB IDE, MPLAB SIM simulator, MPLAB IDE Project Manager and general editing and debugging features.

**Programmers** – The latest information on Microchip device programmers. These include the PRO MATE® II device programmer and PICSTART® Plus development programmer.

## CUSTOMER SUPPORT

Users of Microchip products can receive assistance through several channels:

- Distributors
- Local Sales Office
- Field Application Engineers (FAEs)
- Corporate Applications Engineers (CAEs)
- Systems Information and Upgrade Hot Line

Customers should call their distributor or field application engineer (FAE) for support. Local sales offices are also available to help customers. See the last page of this document for a listing of sales offices and locations.

Corporate applications engineers (CAEs) may be contacted at (480) 792-7627.

### Systems Information and Upgrade Line

The Systems Information and Upgrade Information Line provides system users with a listing of the latest versions of all of Microchip's development systems software products. Plus, this line provides information on how customers can receive the most current upgrade kits. The Information Line Numbers are:

1-800-755-2345 for U.S. and most of Canada.

1-480-792-7302 for the rest of the world.

# PICDEM™ CAN-LIN 2 User's Guide

---

---

NOTES:

---

---

**Chapter 1. Introduction to the PICDEM™ CAN-LIN 2 Board**

---

---

**1.1 INTRODUCTION**

The PICDEM™ CAN-LIN 2 Development Kit has been developed for the evaluation or development of CAN network nodes utilizing Microchip's PIC18FXX8 family of 28- and 40-pin microcontrollers. This tool is ideal for beginning CAN designers, as well as those new to the PIC18FXX8 family.

The Demonstration Board provides three nodes (two CAN and one LIN bus) that can be configured in numerous ways through jumpers and component selection. The CAN nodes implement basic input and output functionality, and can send and receive CAN bus messages. The Host Software included with the kit allows fine manipulation of the PIC18F458 devices down to the bit level, as well as high-level control of the microcontroller. It also provides predefined templates for demonstration, evaluation and development uses.

**1.2 HIGHLIGHTS**

This chapter discusses:

- PICDEM CAN-LIN 2 Development Kit Contents
- Overview of the PICDEM CAN-LIN 2 Board
- PICDEM CAN-LIN 2 Board Features
- CANKing Host Software

**1.3 PICDEM CAN-LIN 2 DEVELOPMENT KIT CONTENTS**

Your PICDEM CAN-LIN 2 Development kit contains the following items:

1. PICDEM CAN-LIN 2 Development Board, complete with three Microchip microcontrollers (two PIC18F458 controllers and one PIC16C432) preprogrammed with demo firmware.
2. A universal power supply (110-230 VAC input, 12 VDC output) and power cable for the Development Board.
3. A male-to-female DB9 serial cable for use in communicating with the board.
4. The PICDEM CAN-LIN 2 CD-ROM with CANKing host software, User's Guide and other supporting documents.
5. A warranty registration card.

## 1.4 OVERVIEW OF THE PICDEM CAN-LIN 2 BOARD

Most demonstration or evaluation systems use a single microcontroller, and are designed to show off that controller's features. While this makes sense in most situations, it also means that users must set up several boards to evaluate even a simple network of a few nodes. The drawbacks to this arrangement should be obvious.

In contrast, PICDEM CAN-LIN 2 provides three network nodes on one circuit board. By using a common power supply and allowing the nodes to be configured in multiple ways, the process of evaluating and developing network nodes can be significantly streamlined.

The three nodes on the PICDEM CAN-LIN 2 board are:

- Node0, a CAN node implemented with either a 28-pin PIC18F248/258 or 40-pin PIC18F448/458 microcontroller. This node interfaces to the external host computer through a standard serial (RS-232) interface, and is directly controlled by the host software. It monitors both the on-board and external CAN busses, and can be used for basic PIC18FXX8 evaluation/development.
- Node1, a CAN node also implemented with either a PIC18F248/258 or PIC18F448/458. This node communicates with Node0 over the on-board CAN bus. It also implements the CAN-to-LIN bus gateway to Node2 (below), and acts as the LIN bus master node. Like Node0, Node1 can also be used for basic PIC18FXX8 evaluation/development.
- Node2, a LIN bus slave node, is implemented with the 20-pin PIC16C432 microcontroller with integrated LIN bus transceiver. It communicates to Node1 via the LIN bus.

Both the CAN and LIN busses are routed off-board through a connector, which allows the board to be connected to an external bus.

### 1.4.1 Benefits of Using the PICDEM CAN-LIN 2 Board

Putting three nodes on one board gives the developer some definite benefits:

**MULTIPLE HARDWARE CONFIGURATIONS WITH ONE BOARD:** Of course, the PICDEM CAN-LIN 2 board accommodates a large selection of CAN and LIN node combinations. When all three nodes are used, sixteen different combinations of microcontrollers are possible, depending on which sockets are populated for the CAN nodes. In addition, users can implement any one of three oscillator configurations for the CAN nodes, or easily add other hardware to the board using the prototyping area and headers.

Many of these configuration changes are performed with jumpers, while others require component additions or removals. The board configurations and jumper locations are discussed in detail in chapters 5 and 6.

**EASIER CAN NODE EVALUATION:** The CANKing host software included with the PICDEM CAN-LIN 2 Development Kit allows for fast evaluation of CAN node operation, as well as the CAN protocol. Using one of the included template sets, users can evaluate everything from bit-level status of registers to node operation and bus status. The host software and the templates are discussed in detail in Chapter 3 and Chapter 4.

**ENHANCED CAN NODE DEVELOPMENT:** Including two CAN nodes on the PICDEM CAN-LIN 2 board provides an additional tool for developing PIC18FXX8-based CAN nodes, either by themselves or together. For example, a user might use the controller in Node1 to prototype a CAN node, while using Node0 as a simple bus monitor (using the basic template). Node0 could also be used as a tool to set or verify bit timings, masks or filters.

# Introduction to the PICDEM™ CAN-LIN 2 Board

---

The possibilities are not limited to what can be developed with just the nodes on the board, either. For example, Node0 can be included as part of a more complex developmental network of many CAN nodes, and serve as the “tap point” for monitoring the entire network.

## 1.5 PICDEM CAN-LIN 2 BOARD FEATURES

As mentioned, the PICDEM CAN-LIN 2 board consists of two CAN nodes and one LIN node. Node0 acts as the main node. It interfaces with the host software through a serial connection (RS-232), and either executes commands from the host system or passes them to Node1. Node0 also interfaces with the on-board LCD header. If an LCD is connected, Node0 can display text messages under host software control.

Node1 also acts as a CAN node, and demonstrates a CAN-to-LIN bridge. This node is controlled via Node0, which relays commands for Node1 from the host system. Node1 receives these messages and performs the appropriate actions. This node also acts as a LIN master mode and provides CAN-to-LIN bridge functionality to Node2. As a LIN master, it receives messages from Node0 and relays them to the LIN slave node.

Node2 is a LIN slave node implemented by the PIC16C432. This node contains an integrated LIN bus transceiver. It waits for commands from Node1 and performs the appropriate actions.

As configured from the box, the behavior of the CAN nodes is determined by its hardware configuration. While Node0 and Node1 both execute the exact same code, the function of the node is decided by its hardware configuration. When either node is reset, its firmware attempts to communicate with the external EEPROM. If the EEPROM is found, the code assumes the role of Node0, and uses the USART to communicate with the host system. If the EEPROM is not found, it assumes the role of Node1 and uses the USART for LIN bus communication. Since the EEPROM is hard-wired to the Node0 controller, this essentially ensures that this controller will always be Node0.

Node0 and Node1 are connected via the on-board CAN bus, which is also available to an external CAN bus through a D-shell connector. Node1 and Node2 are connected via on-board LIN bus. Node1 uses a separate LIN transceiver while Node2 uses an integrated LIN transceiver. The board routes on-board LIN bus to 3-pin header for connection to external LIN devices.

The overall layout of the board is shown in Figure 1-1.

FIGURE 1-1: THE PICDEM CAN-LIN 2 BOARD (TOP ASSEMBLY VIEW)

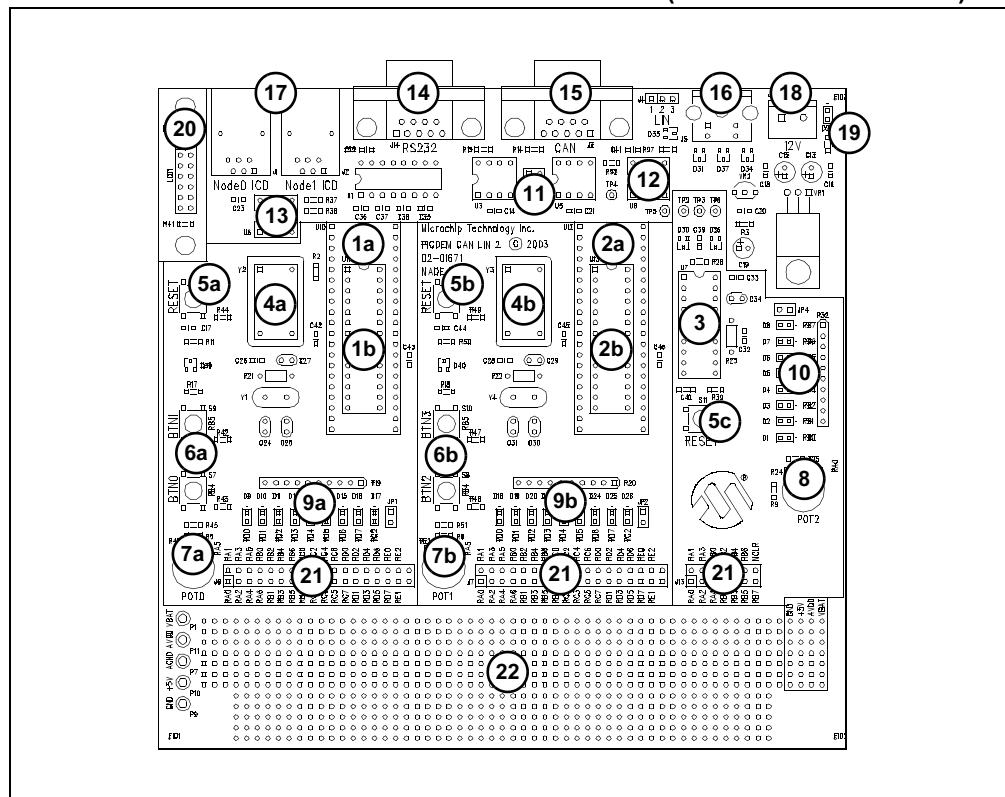

The main features of the board include:

1. **Node0 Microcontroller:** The board is equipped with a pair of nested DIP sockets, designed to accommodate the 40-pin PIC18F448/458 (1a) or the 28-pin PIC18F248/258 (1b); each includes an integrated CAN module. The Node0 microcontroller also handles the communications to the host computer (via RS-232), as well as the external serial EEPROM and the optional LCD module.
2. **Node1 Microcontroller:** This is also a nested DIP socket pair that can accommodate either the PIC18F448/458 (2a) or PIC18F248/258 (2b). This node communicates with Node0 and any external CAN nodes over the on-board CAN bus. It also serves as the LIN master, and communicates to Node2 and other external LIN nodes over the on-board LIN bus.
3. **Node2 Microcontroller:** This is a 20-pin DIP PIC16C432 with integrated LIN bus transceiver. It acts as a LIN slave and transfers data to and from Node1.
4. **Oscillators:** Node0 and Node1 each support three different oscillator configurations (Crystal, RC and Canned). The board is factory equipped with 25 MHz canned oscillators for both of the CAN nodes. If a different oscillator type is required, the board hardware must be reconfigured (see Section 5.3 "Oscillator Configurations" for more information). Node2 uses an RC oscillator only (not shown). It cannot be reconfigured.
5. **Reset Push Buttons:** Each of the microcontrollers has its own RESET push button switch, tied to the MCLR pin. Pressing the switch causes a hard controller reset.
6. **CAN Node User-Defined Switches:** Two push button switches are connected to each the CAN nodes to simulate digital inputs. Their status can be monitored through the host software.

# Introduction to the PICDEM™ CAN-LIN 2 Board

---

7. **CAN Node Potentiometers:** These analog potentiometers (7a and 7b) are connected to Node0 and Node1, respectively. These potentiometers simulate analog inputs for their controllers, and control the brightness of the PWM-controlled LED on the *other* CAN node (i.e., the Node0 potentiometer controls the brightness of Node1's LED, and vice versa). Their real-time status is also displayed by the host software.
8. **Node2 Potentiometer:** This analog potentiometer is connected to Node2. When Node2 is configured for "Poll Automatically" option, the real-time status of this potentiometer is displayed by the host software.
9. **CAN Node LED Banks:** Both Node0 and Node1 are connected to their own bank of nine LEDs: one 8-bit LED port and one PWM-controlled LED. The 8-bit LED shows the (digital) status of PORTD of the controller, and can be modified under software control. The output of the PWM-controlled LED is continuously variable, and is determined by the value of the *other* CAN node's potentiometer (7a or 7b), as noted. For the LEDs to function, their associated LED Enable jumper (JP1 or JP2) must be installed.
10. **Node2 LED Bank:** An 8-bit LED port is connected to PORTB of the LIN slave node, and shows its (digital) status. The display can be modified under software control. The LED Enable jumper JP4 must be installed for the bank to function.
11. **CAN Transceivers:** The MCP2551 transceivers (one for each CAN node) convert the differential signal on the CAN bus to levels that are compatible with the PIC18 microcontrollers.
12. **LIN Transceiver:** The MCP201 transceiver converts the high-voltage signals from the LIN bus to levels compatible with the PIC16 microcontroller.
13. **External EEPROM:** A 24LC16 serial EEPROM is included for the use of developers in creating a full range of prototype devices. This is a 16 Kbit device which is programmable by a two-wire I<sup>2</sup>C™ interface. The EEPROM memory is controlled by Node0. Its contents may be read or modified via the host software interface.
14. **RS-232 (DB9F) Port:** A standard D-shell connector provides a serial connection to control and monitor the Demonstration Board. Since it uses a standard 232 level shifter, this connector can also be used as a standard serial port for prototype applications.
15. **CAN Connector (DB9M):** This connector allows the on-board CAN nodes to be connected to an external CAN bus.
16. **LIN Connector (3-pin) Pad:** A space is provided to add a 3-pin connector, allowing the on-board LIN node to connect with an external LIN bus.
17. **ICD Connectors:** These two 6-wire RJ-11 connectors allow the CAN Node microcontrollers to be connected to an external programmer and programmed on the board.
18. **Power Connector:** Power (12 VDC) is supplied to the board from the power adapter through a 4-pin mini-DIN jack. Alternatively, external power can be provided through the 2-pin terminal block. On-board regulators provide separate +5 VDC sources for analog and digital circuits. Both inputs are protected from accidental polarity reversal. Direct 12 VDC is also available to appropriate circuits.
19. **Power LED (Red):** This is lit to show that power is being supplied to the Demonstration Board.

20. **LCD Connector:** This 14-pin header allows the addition of a standard LCD controller module (such as Hitachi HD4478 or equivalent) to the demonstration board.
21. **Prototype Headers:** These connector pads are provided for users to directly access the I/O port signals for all the microcontrollers. As an option, headers may be installed in these locations.
22. **MCU Prototype Area:** This grid is provided for prototyping controllers that are not supported by the existing sockets. The area is provided with connections for analog and digital power (separate +5 VDC sources), VBAT for LIN (up to +12 VDC) and ground connections.

## 1.6 CANKing HOST SOFTWARE

Included with the Development kit is the CANKing host software. Developed by Kvaser AB, the CANKing package allows users to examine and control the board's operation in detail, as well as monitor CAN node operations. Interfaces are implemented through a series of three pre-designed templates, which are grouped by functionality (CAN node evaluation and control, board-level control, etc.). CAN-related templates are designed around the CAN Kingdom upper-layer protocol primitives; previous experience with this CAN design system is helpful, but not strictly necessary.

Installation and overall operation of the host software is discussed in Chapter 3. The CANKing templates are detailed in Chapter 4.

---

---

## **Chapter 2. Getting Started with the PICDEM™ CAN-LIN 2 Board**

---

---

### **2.1 HIGHLIGHTS**

This chapter will cover the following topics:

- Host Computer Requirements
- Using the PICDEM™ CAN-LIN 2 Board For the First Time
- Checking the Board in Evaluation Mode

### **2.2 HOST COMPUTER REQUIREMENTS**

To communicate with and program the PICDEM™ CAN-LIN 2 Development Board, you must have a system that meets the following hardware and software requirements:

- PC-compatible system with an Intel 80486 class or higher processor, or equivalent
- A minimum of 16 MB RAM
- A minimum of 5 MB available hard drive space
- CD-ROM drive (for use with the accompanying CD)
- One available standard serial port, with a matching COM port available through the operating system
- Microsoft Windows® 95, or any 32-bit version of Microsoft Windows (Windows 98, Windows NT®, Windows 2000 or Windows XP)

### **2.3 USING THE PICDEM CAN-LIN 2 BOARD FOR THE FIRST TIME**

For evaluating the PICDEM CAN-LIN 2 board, the simplest configuration uses a host computer connected directly to the board using a crossover cable. Creating this setup involves the following steps:

1. Installing the CANKing Host Software
2. Connecting the PICDEM CAN-LIN 2 board to the host system
3. Starting the Host Software

## 2.3.1 Installing the Host Software

The installation of the host software package is completely automated and does not require any user intervention or configuration once the process is started. The process is identical for all 32-bit Windows operating systems. Users with Windows NT-based desktops (NT 4.0, 2000 and XP) should not need to have administrative rights to their systems for this installation. Closing all background applications before proceeding is helpful, but not required.

**Note:** It is possible that some organizations may implement a desktop computer policy sufficiently restrictive to prevent the user from loading any software at all. In theory, this can be done with **any** 32-bit Windows operating system on a network – including Windows 95. If this describes your situation, contact your local Information Services provider for assistance in installing this software.

To install the host software:

1. Insert the PICDEM CAN-LIN 2 Software CD into your system's CD-ROM drive.
2. Double-click on "My Computer", then on the icon for the CD-ROM.
3. Double-click on the "wc32mchip\_pic.exe" icon. Installation will proceed automatically and take 1-2 minutes.

Alternatively, run the installation by selecting *Run* from the Start menu. At the dialog box, enter:

```
x:\wc32mchip_pic
```

where "x" is the drive letter of your CD-ROM.

The installation process will install the host software package, as well as the templates and help files. By default, all files are installed by default in the directory `Program Files\Microchip` under the root level of your hard drive. A shortcut for the host software is also installed under Programs from the Start menu (*Programs > Microchip > CANKing*).

**Note:** Always use the suggested default path for installing the host software. Because of certain software dependencies, it may not work correctly if installed elsewhere.

## 2.3.2 Connecting the PICDEM CAN-LIN 2 Board

The basic connections are shown in Figure 2-1.

1. Power-down the host system. (This isn't strictly necessary, but it's always a good safety idea – particularly if you need to rearrange cables or move the system.)
2. Unbox and unwrap the board, and set it on a non-conductive surface near the host system.
3. If they aren't installed already, install the microcontrollers in their respective sockets. Check that they are completely seated and that all pins are making contact.

# Getting Started with the PICDEM™ CAN-LIN 2 Board

FIGURE 2-1: CONNECTIONS BETWEEN THE PICDEM CAN-LIN 2 BOARD AND THE HOST COMPUTER

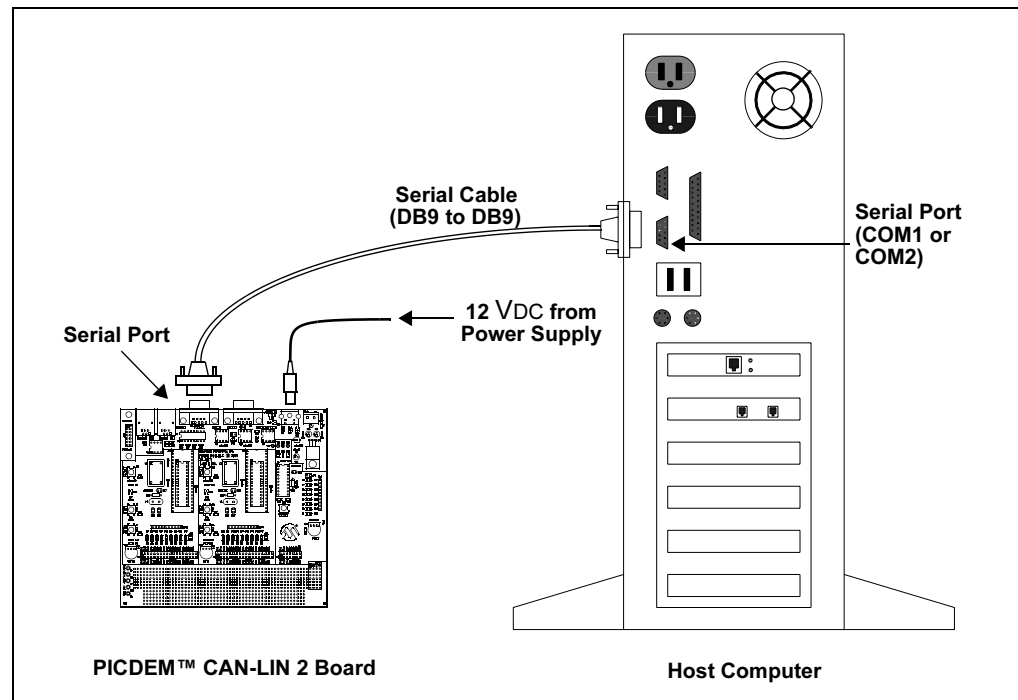

4. Connect the serial cable (supplied in the kit) to the RS-232 connector on the board, then to the open serial port on your computer.

**Note:** If your available serial port is a DB25 male connector, you will need to use a DB25F-to-DB9M port adapter, sometimes known as an “external modem adapter”. Check with your local electronics parts store or your Information Services provider for additional information.

5. Connect the mini-DIN plug of the power supply to the Power Input jack on the board.
6. Plug the power adapter into your wall socket or power strip.
7. Check the board. The red Power LED should light, and the Node0 port LEDs should briefly flash once. If they don't, check all connections with the power supply and the board. For additional assistance, refer to Chapter 6 ("Troubleshooting").
8. Power-up the host system.

## 2.3.3 Starting the Host Software for the First Time

With the software installed and the PICDEM CAN-LIN 2 board connected, all you need to do is to actually start the host software and confirm communications.

1. From the Start menu, select *Programs > Microchip > CANKing*;

**OR**

From a command window (DOS® window on Windows 95/98), navigate to the directory \program files\microchip, then enter:

```
wc32
```

However it is started, the CANKing welcome dialog box appears (Figure 2-2).

**FIGURE 2-2: THE CANKing WELCOME DIALOG**



2. Select the “Start using CANKing” option. Optionally, to remove the dialog from future start-ups, check the “Don’t ask me again” box. Click on **OK**.
3. At the subsequent “Warning!” dialog, click on **OK, I Know What I’m Doing** to proceed. Optionally, check “Don’t show me this warning in the future” to remove this dialog from future start-ups.

**Note:** The cautions against personal injuries in this dialog refer to those cases where the PICDEM CAN-LIN 2 board is being used in the evaluation and development of live automotive and industrial networks. Obviously, this doesn’t apply to situations where the board is being used in isolation to prototype network nodes.

4. At the next dialog box (Figure 2-3), select the “Template” option under “Create a New Project Using”. Click **OK**.

# Getting Started with the PICDEM™ CAN-LIN 2 Board

FIGURE 2-3: CREATING A NEW PROJECT

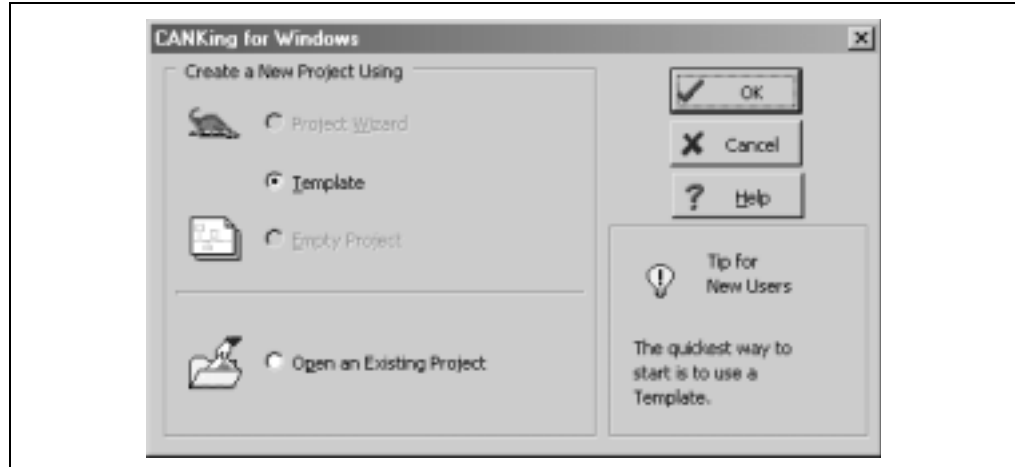

5. At the "Templates" dialog, select "PIC18+CAN Evaluation Board". Click on **OK**.
6. A series of smaller windows and dialog boxes is launched as part of the Evaluation Board template (Figure 2-4). Go to the "CANKing for Windows" menu at the top of the screen and select *Options > PIC18+CAN...* (you will need to close the "Tip of the Day" window at center screen first).

FIGURE 2-4: THE EVALUATION BOARD TEMPLATE AT LAUNCH (CANKing MAIN MENU BAR AT TOP LEFT)

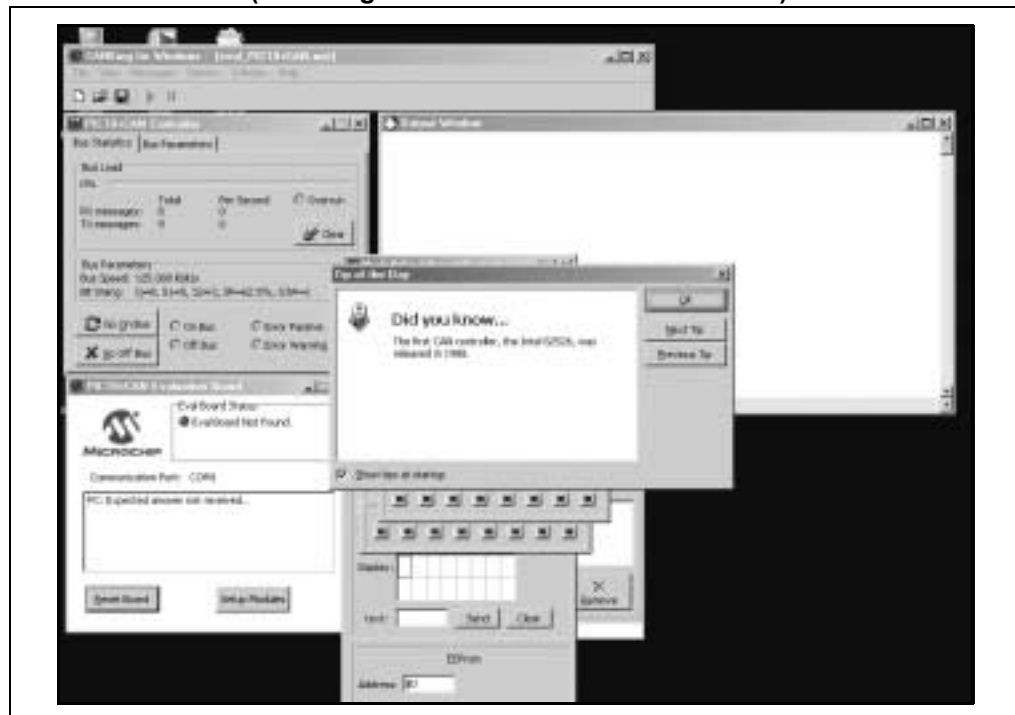

7. At the "Evaluation Board Options" dialog, select the following options from the appropriate drop-down menus:
  - Clock Frequency: 25000 kHz (25 MHz)
  - COM Baud Rate: 38400 bps
  - COM Port: (the port that the board is connected to)Under "Options for the Current Configuration", check "Reset PIC18+CAN on Open".  
Click **OK**.
8. In the Evaluation Board window (which launched along with the other windows of the Evaluation Board template), the "Connected" status indicator turns green, and a message indicating a successful serial connection appears.  
Click on **Reset Board**. The green light stays on, and the message below it changes to "Eval Board is in Disable Mode" (Figure 2-5).

**FIGURE 2-5: THE EVALUATION BOARD WINDOW, SHOWING A SUCCESSFUL CONNECTION**

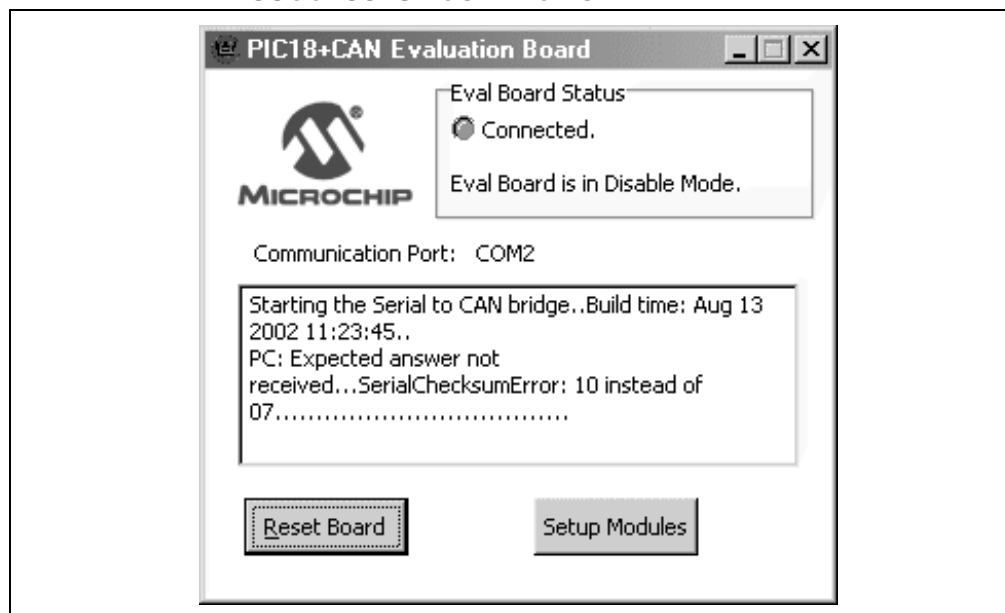

9. In the CAN Controller window, click on **Go on Bus**. The On Bus light turns green. At the same time, the message in the Evaluation Board window changes to "Eval Board is in Normal Mode".
10. In the Evaluation Board window, click on **Setup Modules**. Output information from the board appears in the Output window.

The PICDEM CAN-LIN 2 board is now ready to respond to control inputs from the host software.

# Getting Started with the PICDEM™ CAN-LIN 2 Board

---

## 2.4 CHECKING THE BOARD IN EVALUATION MODE

While the board is connected to the host system and the host software is using the Evaluation template, it may be useful to verify its operation. This is also a good way to show off the board's capabilities.

After following the instructions in Section 2.3 "Using the PICDEM CAN-LIN 2 Board for the First Time", do the following:

1. Slowly turn the Node0 potentiometer clockwise and counterclockwise. The right most LED of Node1's LED bank should brighten and dim. At the same time, the "Pot Value" displayed in the Node0 Eval Board window should increase and decrease, while the "PWM Intensity" indicator in the Node1 Eval Board window should increase and decrease by the same amount.
2. Slowly turn the Node1 potentiometer clockwise and counterclockwise. The right most LED of Node0's LED bank should brighten and dim. At the same time, the "Pot Value" displayed in the Node1 Eval Board window should increase and decrease, while the "PWM Intensity" indicator in the Node0 Eval Board window should increase and decrease by the same amount.

**Note:** While this may seem anti-intuitive, using one node's potentiometer to affect the other's LED does prove a point. For this demonstration, we are showing that an analog input from one microcontroller can be communicated across the CAN bus to control the PWM output of the other microcontroller.

3. Click on any of the LED buttons in either of the CAN node's windows. The corresponding LED on the board should toggle on or off.
4. In the Node2 Eval Board window, select the "Count LEDs" check box. Both the LED buttons in the window, as well as the Node2 LEDs on the board, should start counting up in binary and in sync with each other.

If all of these tests worked, you are now ready to start working with the board.

# PICDEM™ CAN-LIN 2 User's Guide

---

---

NOTES:

---

---

## Chapter 3. Getting Started with the CANKing Software

---

---

### 3.1 HIGHLIGHTS

The items discussed in this chapter are:

- Software Overview
- Starting the Program
- Introduction to the Templates
- The Main Menu
- The Output Window
- Customizing Projects

### 3.2 SOFTWARE OVERVIEW

The CANKing Host Software provides a comprehensive interface to control the board's operation. To make things easier, the program uses three distinct, pre-defined templates that perform specific functions.

**Note:** Using the CANKing Host Software requires that the PICDEM™ CAN-LIN 2 board's microcontrollers be programmed with the demo firmware. Since the CAN firmware is designed to run on PIC18F458 microcontrollers only, using any configuration in Node0 and Node1 other than two PIC18F458 microcontrollers precludes the use of CANKing Host Software. The board can still be used in other configurations for prototype development.

### 3.3 STARTING THE PROGRAM

To run CANKing, select *Programs > Microchip > CANKing*. from the Start menu. Alternatively, double-click on the CANKing icon or shortcut.

If you have not disabled them on the first use of the software, you will see the initial CANKing dialog and Warning window (see Section 2.3.3 "Starting the Host Software for the First Time" for details). If they appear, click **OK** at these dialogs to continue.

At the Open a Project or Template dialog (simply titled "CANKing for Windows"), select the "Template" option for creating a new project. (The other options listed are not available in this version of CANKing and should be dimmed.) Click **OK**.

At the "Templates" dialog, select the appropriate template and click **OK** to launch it. You can also directly launch the template by double-clicking on its icon.

If you have an alternate template or project you wish to use, select the "Open an Existing Project" option at the "Open a Project" dialog. A standard Windows dialog allows you to browse for the desired folder. Custom projects and templates are covered in more detail in Section 3.7 "Customizing Projects".

## 3.4 INTRODUCTION TO THE TEMPLATES

Much of the host software's versatility comes from its use of pre-defined templates. Because of the potential complexity of managing a microcontroller at the bit level – let alone a network protocol such as CAN – the problem of organizing all the information and controls that a user might need to evaluate and manage becomes a major challenge. CANKing simplifies matters by grouping all the necessary controls for a particular type of task into a template. Launching the template activates the necessary individual control or monitor windows that are required for the task. Users have the option to close or reopen particular windows as needed.

The individual templates and their controls are covered in detail in Chapter 4 ("Using the CANKing Templates"). A brief overview is given below.

### 3.4.1 PIC® Register View Template

The PIC Register template allows low-level control of Node0. It is typically used to evaluate and test the PIC18FXX8 at the register and bit level. All of the registers required for complete configuration of the CAN module are available in this template.

### 3.4.2 Basic Template

The Basic Template is a high-level tool which focuses on CAN bus traffic. It is typically used to observe the PIC18FXX8 while on the bus. The development of a CAN node based on Node1 can be evaluated by using this template with Node0.

### 3.4.3 PIC18+CAN Evaluation Board Template

The Evaluation Board template provides real-time control of the entire board as a demonstration tool. It allows users to control the LEDs for each of the nodes and monitor in real-time the status of the user push buttons and potentiometers.

## 3.5 THE MAIN MENU

Launching any of the templates, or opening any existing CANKing project, always places a common toolbar at the top of the screen. The overall operation of CANKing is controlled from here. The menu options available are, with a very few exceptions, universal across all of the templates.

The *File* menu implements a standard set of Windows options. Users can create a new project, save an existing project, open or reopen an existing saved project, close the existing project without exiting CANKing and exit CANKing entirely.

The *View* menu allows the user to selectively open and close any of the windows and dialogs available within the template. By default, each template opens only some of the windows available to it. All of the windows available within a template are listed in the View menu, allowing the user to select only those that are needed (or all windows, if required).

The *Messages* menu is context-sensitive. Depending on the template, it either opens (or shifts focus to) a specific configuration or message window, or selects the format for the next CAN message to be sent. This is covered in more detail in Section 4.5 "Template-Specific Variations in the Main Menu".

The *Options* menu sets program-wide operational options for CANKing. The *PIC18+CAN...* selection configures hardware and communication options with the board (see Figure 2-3). The *Global...* selection configures software options for CANKing's operation, such as the displayed numeric base of data and auto-save on exit.

# Getting Started with the CANKing Software

The *Window* menu lists the open windows and dialogs, and lets the user bring any one of the windows to the foreground. Unlike the View menu, this menu only shows those windows which are active.

The *Help* menu provides access to indexed and interactive on-line product help, as well as Internet links to Kvaser's CANKing web site. Context-sensitive help is also available by pressing F1.

The main menu toolbar (Figure 3-1) is the same for all templates. It provides standard Windows toolbar buttons for creating a new project, and opening and saving an existing project. Icons are also provided to go on and off the CAN bus; they are always present, but functional only in the Basic and Evaluation templates.

**FIGURE 3-1: THE CANKing MAIN MENU**

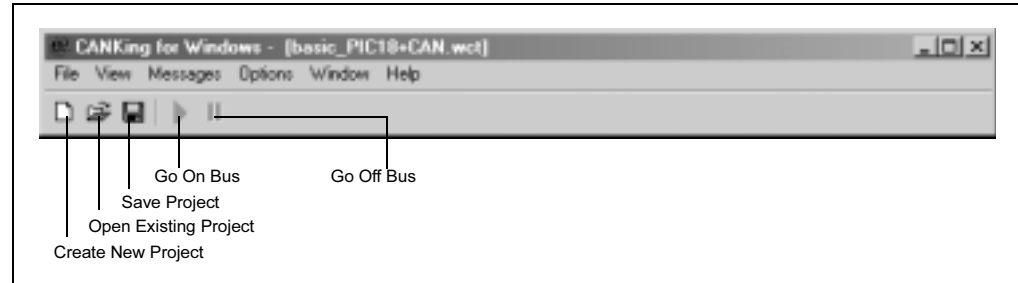

## 3.6 THE OUTPUT WINDOW

Common to both Basic and PIC18+CAN Evaluation templates is an output window, which displays the messages that are received and transmitted by Node0. This window can be reconfigured to display messages in different formats. The formats are changed using a combination of the Message Formatter dialog box and the right mouse button.

The Message Formatter window (titled "Select Formatter") selects one or more of several predefined formats for the window. The format type may be specific to a particular usage (e.g, a King's page interpreter or a LIN bus message interpreter) or a generic text format. More than one formatter may be selected, and their order of display may be arranged at will. Many of the formats can be fine-tuned with their own configuration options. For additional information, see Section 4.3.3 "Select Formatters Window".

Using the right mouse button in this window brings up a menu with several options:

- *Options* allows the user to set the font used in the window, as well as the maximum number of lines available in the window's buffer.
- *Fixed Positions* effectively assigns a slot for each message identifier. As messages with the same ID are received or transmitted, they overwrite the contents of the previous message with the same ID. Used in conjunction with the delta time feature, the frequency of each message type can be observed.
- *Copy to Clipboard* copies the contents of the window's buffer to the Windows clipboard.
- *Clear* empties the window and its buffer.

FIGURE 3-2: TYPICAL OUTPUT WINDOW (STANDARD TEXT FORMAT SHOWN)

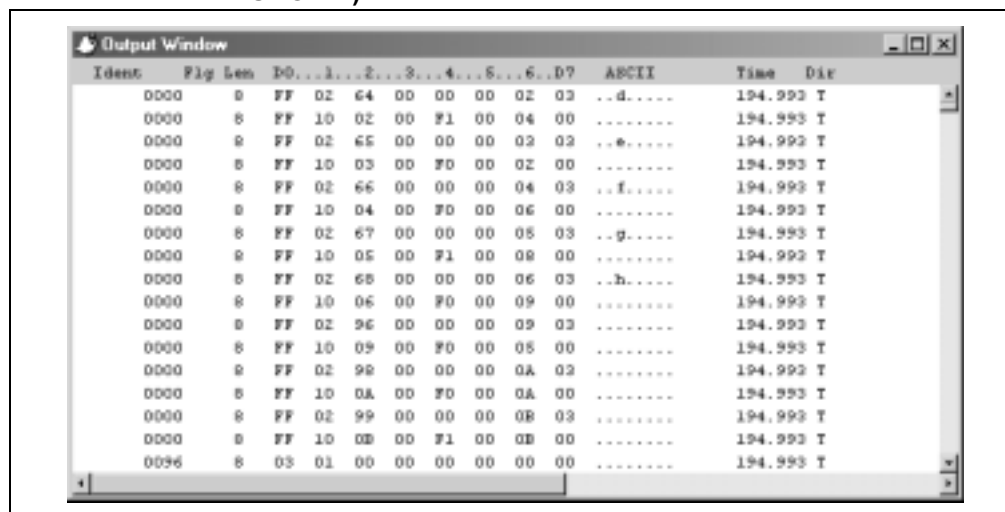

## 3.7 CUSTOMIZING PROJECTS

The templates furnished with the CANKing host software provide a quick way to connect to the PICDEM™ CAN-LIN 2 board and examine its operation. As you gain experience with the board and the software, however, you may want to customize your environment. For example, you may want to launch a different set of controls than those that a particular template uses as its default. Alternatively, you may want to use different communications settings. The host software accommodates these needs by allowing users to save CANKing projects with their particular settings, preserving both hardware and window configurations.

To save a configuration, use the *File > Save As* menu option. CANKing allows you to save either as a project (.wcc file extension), or a new template (.wct extension). A standard Windows dialog permits you to browse folders for the desired location.

To open a previously saved project, either choose the "Open an Existing Project" from the dialog box, or use the *File > Open* menu option. A standard Windows dialog box permits you to browse folders for the desired file.

## Chapter 4. Using the CANKing Templates

### 4.1 HIGHLIGHTS

The items discussed in this chapter are:

- PIC® Register View Template
- The Basic Template
- PIC18+CAN Evaluation Board Template
- Template-Specific Variations in the Main Menu

### 4.2 PIC® REGISTER VIEW TEMPLATE

This template allows low-level control of Node0. It is typically used to evaluate and test the PIC18FXX8 microcontroller at the bit level. All of the registers required for complete configuration are available in this template.

Values for buffer and control registers can be changed on both the byte and bit levels. To modify the register on a byte level, enter the value in the boxes next to the register names. Notice that the bit values will reflect the entered byte values.

To modify the registers at the bit level, double-click the desired bit. The bit will toggle for each double click and the byte representation will be reflected next to the register name. The bit boxes are only modifiable when unshaded. Shaded bit boxes are read only bits.

**FIGURE 4-1: PIC REGISTER VIEW TEMPLATE (WHOLE-SCREEN VIEW SHOWING THE AVAILABLE WINDOWS AT START-UP)**

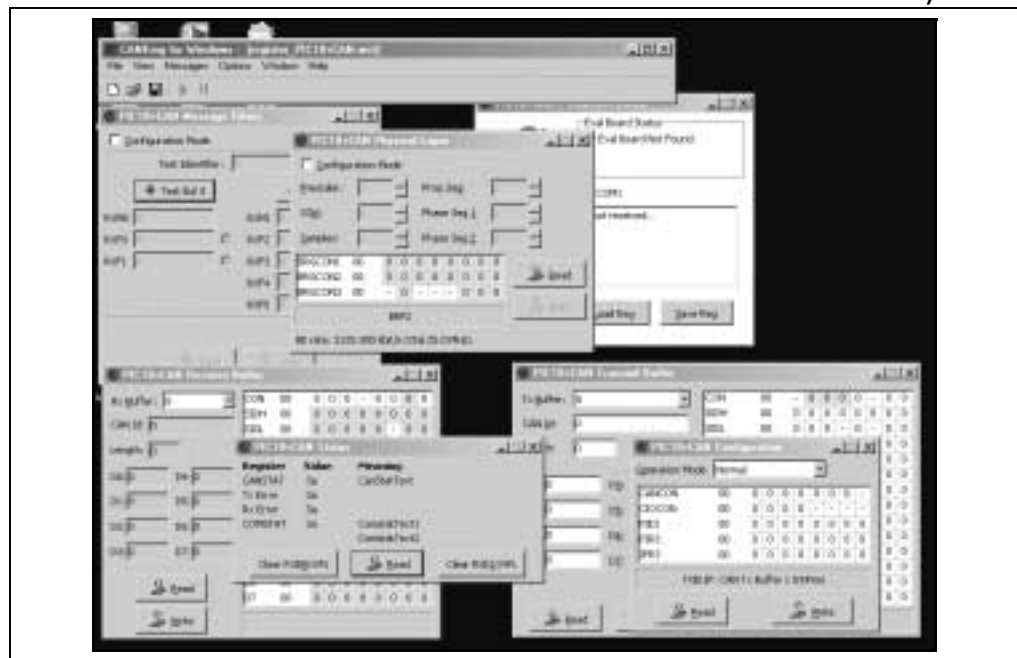

## 4.2.1 PIC18+CAN Evaluation Board

This window is functionally available in all three templates, but is named and configured in a slightly different manner for each. In each template, it displays the current communication status with the board. When a successful connection is detected, the “Eval Board Status” LED turns green and displays a “connected” message. The window also shows the current COM port setting and any log messages as the host software communicates with the board.

In the PIC Register template, the window provides three control buttons. “Reset Board” causes a RESET of the board’s firmware, and erases all previous settings. “Save Reg” saves the current register values as a HEX file; a standard Windows dialog allows the user to browse for the file location. “Load Reg” restores previously-saved register values from a HEX file, and also uses a Windows dialog to search for the file’s location.

**FIGURE 4-2: PIC18+CAN EVALUATION BOARD WINDOW (REGISTER TEMPLATE VERSION, BOARD NOT CONNECTED)**



## 4.2.2 PIC18+CAN Message Filters

This window is used to set up and test mask and filter combinations with different message identifiers. Each mask and filter can be tested without actually writing the configuration to Node0. This is done to allow the user to test different configurations against message identifiers that would appear on the bus. When the desired mask and filter combinations are achieved, the values can be written to the Node0 by clicking the 'Write' button.

**Note:** The masks and filters can be written only when the Node0 is in Configuration mode.

**FIGURE 4-3: MESSAGE FILTER WINDOW**



### 4.2.3 PIC18+CAN Physical Layer

The Physical Layer window is where the CAN bus rate is configured. The user has bit-level control of the three BRGCON registers (BRGCON1, BRGCON2 and BRGCON3), which sets up all items required for CAN bit timing including the time quanta (TQ), bit segments, the synchronization jump width (SJW), and the baud rate prescaler (BRP).

The calculated bit rate is shown at the bottom of the window. For this calculation to be valid, the oscillator value must be correct. To change the oscillator value, select Options->PIC18+CAN... from the main menu.

The BRGCON registers can be modified only when Node0 is in Configuration mode. The bit will be shaded and cannot be modified in other modes of operation.

**FIGURE 4-4: PHYSICAL LAYER WINDOW**

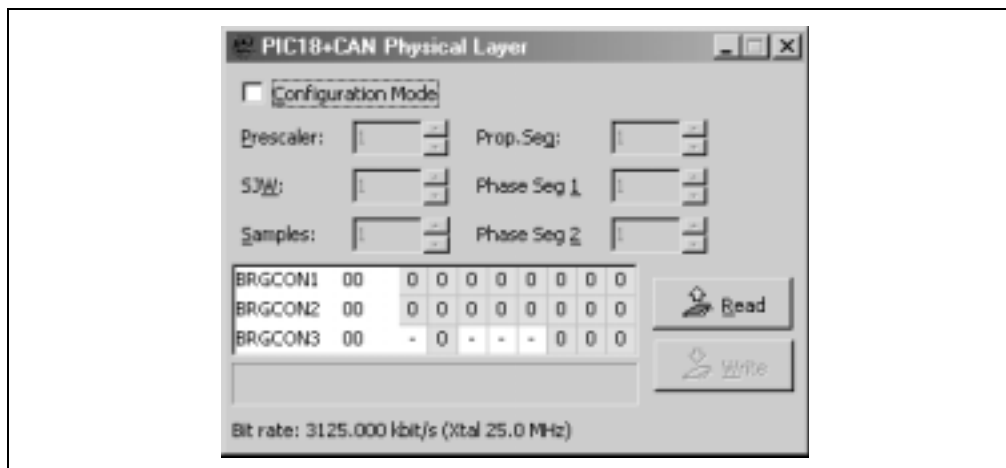

## 4.2.4 PIC18+CAN Receive Buffer

This window contains all of the buffer contents for the receive buffers including RXBnCON, the identifier registers and the data registers.

RXB0CON and RXB1CON are the only registers in this window that are not read-only, as indicated by the unshaded bit locations. These two registers set up the receive modes and enables or disables the hardware double-buffer function.

The Receive Buffer windows allows users to select one buffer to view at a time. Multiple Receive Buffer windows can be opened for simultaneous viewing by holding down the Shift key while selecting the Receive Buffer option from the Windows menu (*Messages > PIC18+CAN Eval Board > Receive Buffer*).

**FIGURE 4-5: RECEIVE BUFFER WINDOW**

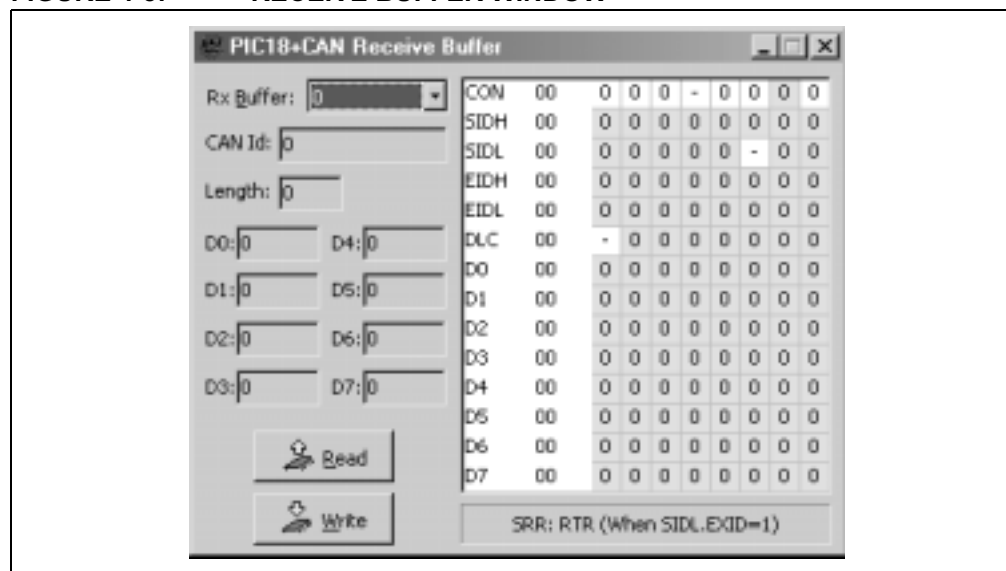

## 4.2.5 PIC18+CAN Status Window

The Status Window displays the contents of the CANSTAT register, the COMSTAT register, and the counts for the receive and transmit error counters. The condition of the registers are also shown (for example, a CANSTAT value of 80h displays the condition as Configuration mode with no interrupts pending).

The window also contains controls to clear overrun conditions for each of the receive buffers.

**FIGURE 4-6: PIC18+CAN STATUS WINDOW**

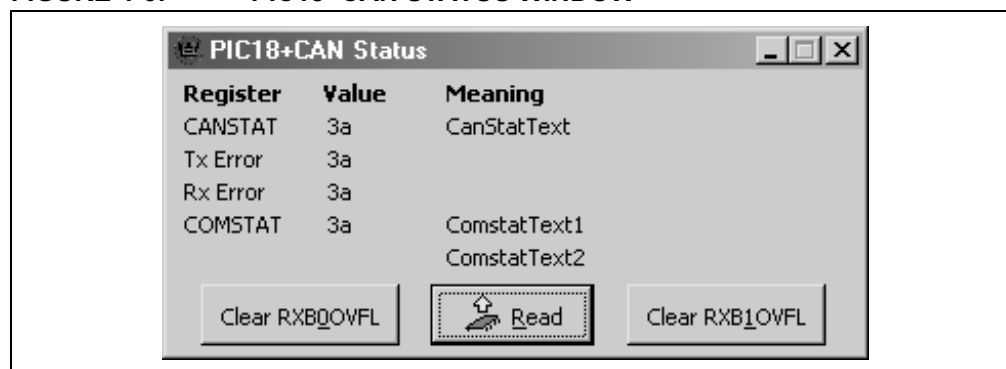

# Using the CANKing Templates

## 4.2.6 PIC18+CAN Transmit Buffer

This window controls the buffer contents for the three transmit registers including TXBnCON, the identifier registers and the data registers.

Like the other register windows, the Transmit Window maps the byte values to the bit boxes. Entering data into the CAN ID box maps to multiple registers (SIDH, SIDL, EIDH and EIDL). For example, entering '1FFFFFFF' in the CAN ID box maps all '1's to SIDH, SIDL, EIDH and EIDL.

Like the Receive Buffer, the Transmit Buffer window allows users to select one buffer to view at a time. Multiple Transmit Buffer windows can be opened for simultaneous viewing by holding down the Shift key while selecting the Receive Buffer option from the Windows menu (*Messages > PIC18+CAN Eval Board > PIC18+CAN Transmit Buffer*).

**FIGURE 4-7: TRANSMIT BUFFER WINDOW**

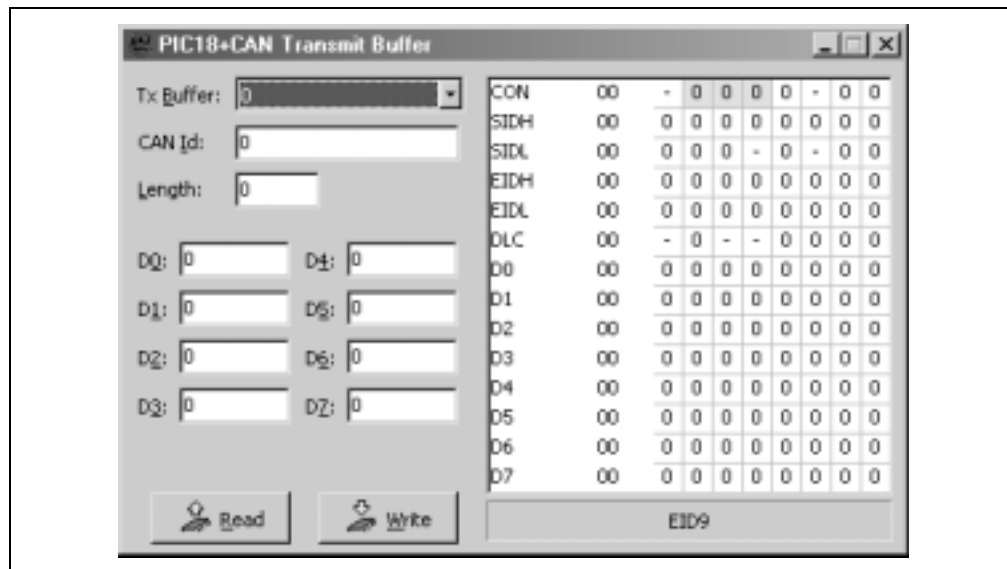

## 4.2.7 PIC18+CAN Configuration

This window displays and can directly control the contents of the CAN control and peripheral interrupt registers (CANCON, CIOCON, PIE3, PIR3 and IPR3). These are the control and flag registers for the PIC18FXX8 microcontrollers.

A complete discussion of the function of these registers is beyond the scope of this manual. Interested readers are referred to the PIC18FXX8 Data Sheet (DS41159) for more information.

FIGURE 4-8: .PIC18+CAN CONFIGURATION WINDOW

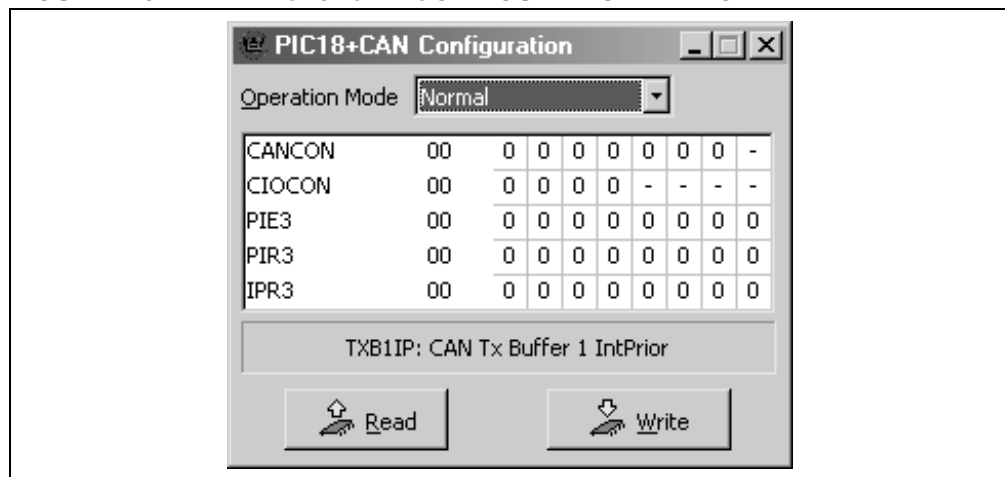

## 4.3 THE BASIC TEMPLATE

The Basic Template is a high-level tool which focuses on CAN bus traffic. The user only has high-level control of Node0 (i.e., no direct register control) which includes:

- Configuring the bus rate
- Changing modes of operation (Configuration and Normal)
- Configuring a transmit register (the register number is predefined)
- Transmitting messages
- Resetting Node0

Other functions of the basic template are receiving messages, saving transmitted messages, starting timed transmissions and observing the bus loading. Details of these functions can be found later in this section under the details of the individual windows.

This template would typically be used as a simple bus monitor that could be used to evaluate the PIC18FXX8 on a CAN bus, or assist in development by monitoring how Node1 is operating.

By default, the Basic template configures Node0 to receive ALL messages. The user has the option to maintain Node0 configurations when switching templates by selecting *Options > PIC18+CAN...* and deselecting the "Reset PIC18+CAN on Opening" check box. Keep in mind that deselecting this box may create unforeseen problems if the Node0 was not configured properly previously.

# Using the CANKing Templates

**FIGURE 4-9: THE BASIC TEMPLATE (WHOLE-SCREEN VIEW SHOWING THE AVAILABLE WINDOWS AT START-UP)**

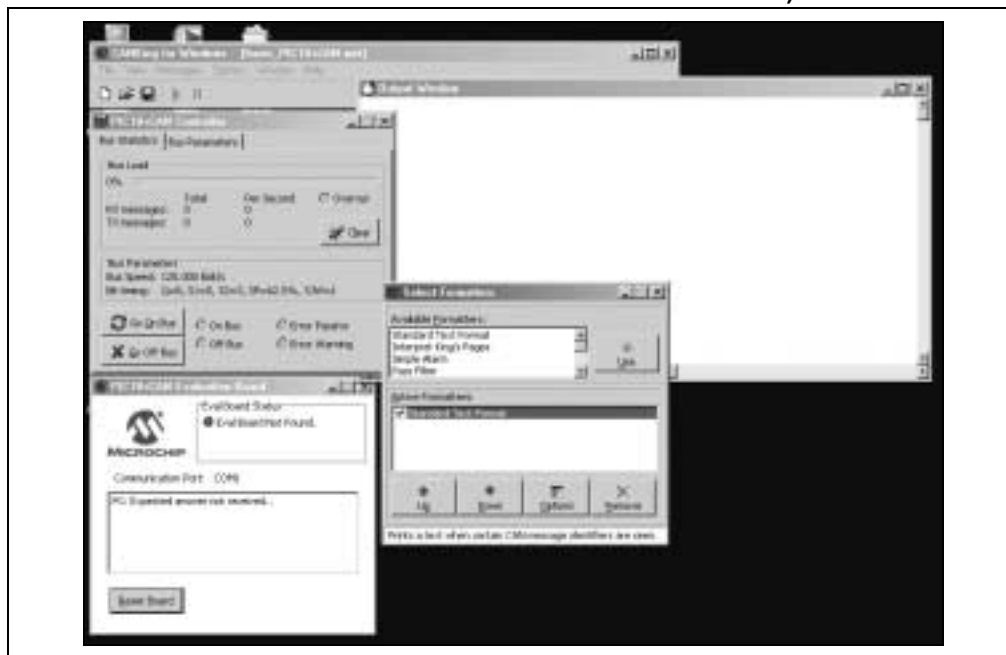

## 4.3.1 PIC18+CAN Evaluation Board

This window is similar in function to the Evaluation Board window in the PIC Register template (Section 4.2.1 "PIC18+CAN Evaluation Board") in displaying the current communication status of the board. For the Basic template, there is only one control, the "Reset Board" button; it resets the firmware and writes power-on default values to all of Node0's CAN registers.

**FIGURE 4-10: PIC18+CAN EVALUATION BOARD WINDOW (BASIC TEMPLATE VERSION)**



## 4.3.2 PIC18+CAN Controller

This window provides information about the status of the bus including nominal bus loading, status of node (on or off the bus), and bus bit rate. The tabs at the top of the window select between “Bus Statistics” and “Bus Parameters” pages.

On the “Bus Statistics” page, the bus loading, bus parameters and bus status can be viewed. The bus loading shows the nominal load on the CAN bus as a percentage and as a number as well as the total number of messages sent and received. The bus parameters reflect the parameters set in the Bus Parameters view (i.e., Bit rate, number of TQ, bit segment lengths and the location of the sample point). The Bus Status shows the mode of operation and error states; this is also where the controls to put the board “On Bus” (Normal Operation) or “Off Bus” (Configuration mode) are located.

Options on the “Bus Parameters” page allow the user to configure the bus rate, the sample point, the Synchronization Jump Width (SJW) and switching between Normal and Listen Only modes of operation.

**FIGURE 4-11: PIC18+CAN CONTROLLER WINDOW**

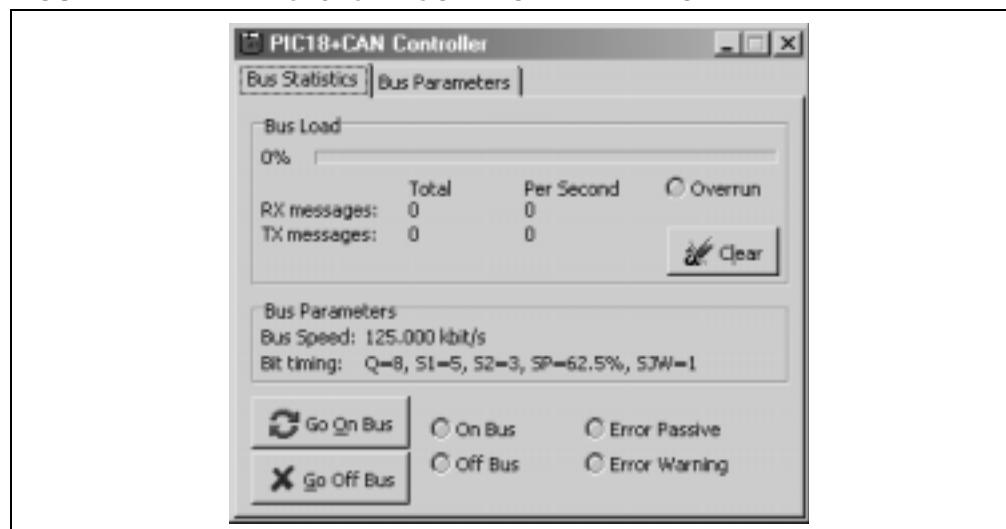

# Using the CANKing Templates

## 4.3.3 Select Formatters Window

This window determines the format of the displayed data in the output window.

CANKing provides a number of pre-defined general and specialized format options for data display. Many of these formats can in turn be fine-tuned with specific configuration options. The default is “Standard Text Format” which displays the message data as normal data.

To add a formatter for the output window, select an option from the “Available Formatters” spin box, and click on the **Use** button. Alternatively, you can double-click on the item. The formatter is successfully selected when it appears in the “Active Formatters” window and its check box is selected.

To deactivate a formatter, select the item from the Active Formatters window and click the “Remove” button. You can also temporarily deactivate an option by deselecting the check box next to it.

To change the order that formatters are applied to the output window, select a formatter in the Active Formatters window and click on the **Up** or **Down** buttons.

The properties of the formatter can be changed by pressing the **Properties** button while the selection is highlighted in the Active Formatter list. The properties of the Standard Text Format are the numeric base of the display (octal, decimal or hexadecimal) and whether or not to display the message time stamp as a running total or as delta time. Many of the other formatters have their own unique configuration properties (e.g., filter limits, message interpreters).

**FIGURE 4-12: MESSAGE FORMATTERS WINDOW**

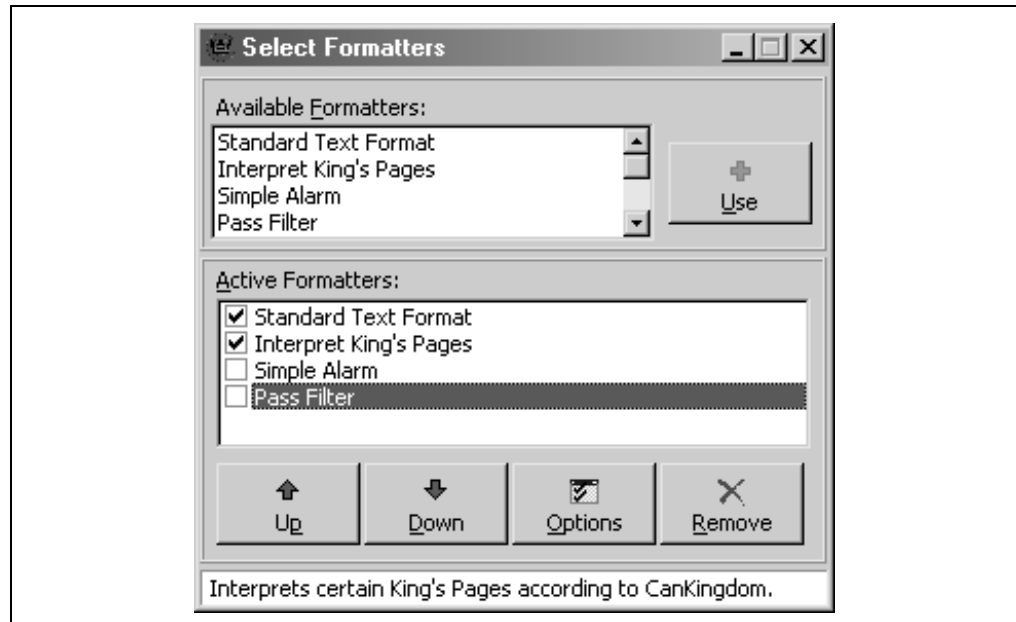

## 4.3.4 Output Window

The output window is discussed in detailed in Section 3.6 “The Output Window”.

## 4.3.5 History List

This window is used to collect transmitted messages for saving to a file. It is not opened by default when opening a new template, but by selecting *View > History List* from the main menu. Once opened, every transmitted message is captured in the History List window for saving to a file if desired. Each line consists of Identifier, Data Len, Data Byte D0 through Data Byte D7. One or more messages can be selected for retransmission. There is also a button for sending all the captured messages.

The History List window works in conjunction with the Timed Transmission window. Messages can be retransmitted once, or continually at defined intervals. See the Timed Transmission window (Section 4.3.6 "Timed Transmission") for more details.

**FIGURE 4-13: HISTORY LIST WINDOW**

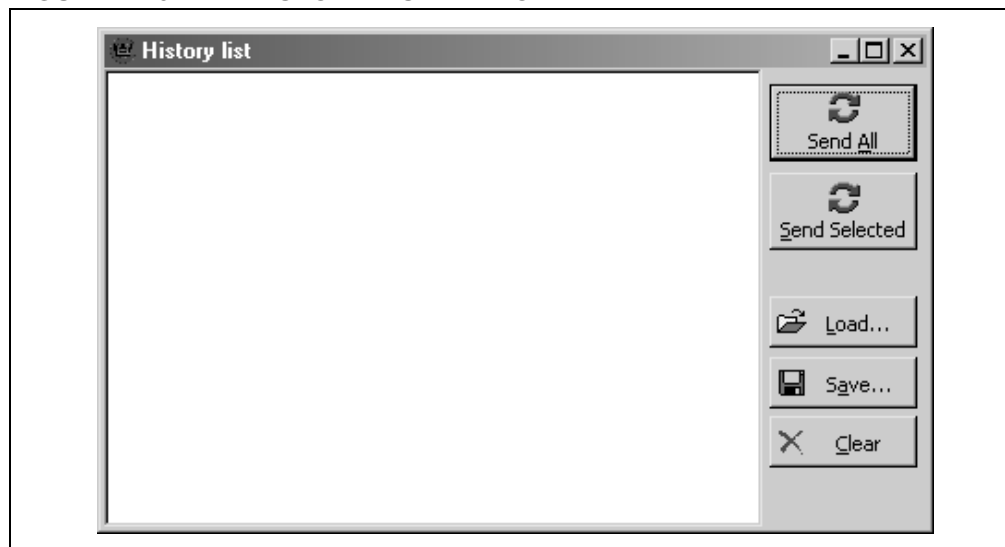

## 4.3.6 Timed Transmission

The Timed Transmissions window is used to send the messages in the history list, either once or continually at timed intervals.

The *One Shot* mode sends the selected (in the History List window) messages one time each time the send buttons are pressed in the History List window.

The *Cyclic* selection sends the selected messages at regular intervals (from 1 ms to 10 s). The interval is set with the fixed-interval spin box.

The other Message Timing selections (*Just-in-Time* and *Manual*) are not available in this version of the software.

**FIGURE 4-14: TIMED TRANSMISSION WINDOW**

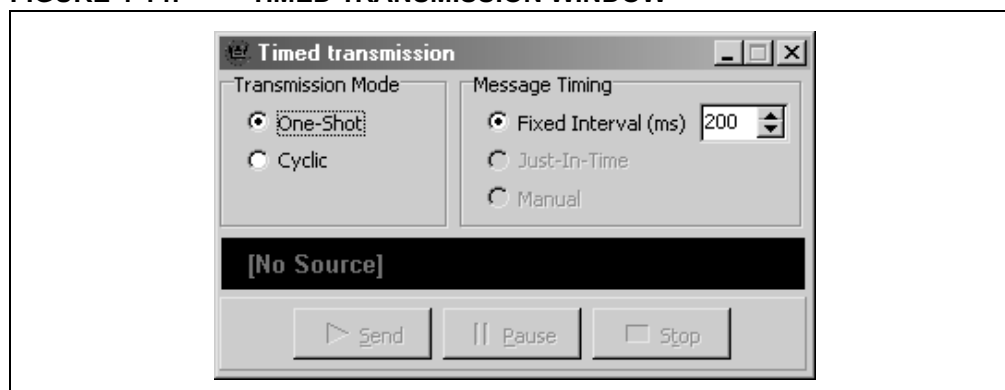

## 4.4 PIC18+CAN EVALUATION BOARD TEMPLATE

For most users, this is the very first template used when the PICDEM™ CAN-LIN 2 board is first set up and configured. It provides real-time control of the board's interactive features, and serves as the demo application for the on-board controls. The individual Board Evaluation windows allow users to, among other things, toggle the LEDs and monitor the real-time status of the push button switches and potentiometers.

**FIGURE 4-15: THE EVALUATION BOARD TEMPLATE (WHOLE-SCREEN VIEW SHOWING THE AVAILABLE WINDOWS AT START-UP)**

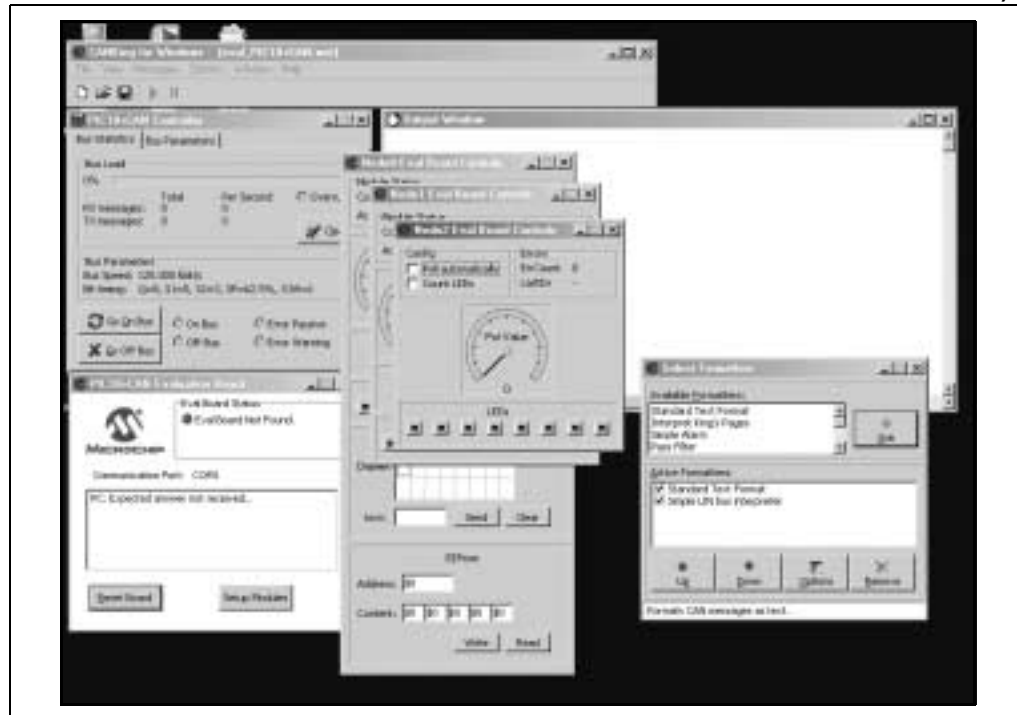

### 4.4.1 Putting the Board in Evaluation Mode

Unlike the other templates, the PIC18+CAN Evaluation Board template requires additional action by the user beyond a firmware RESET. This involves initializing that section of the firmware which allows interactive control of the board's features, which are not available when operating with the other templates. The initial setup described in Section 2.3 "Using the PICDEM CAN-LIN 2 Board for the First Time" describes the process in detail. If the board is already connected, however, it is only necessary to do the following:

1. Open a new project using the Evaluation Board template.
2. In the "PIC18+CAN Controller" window, click **Go on Bus**.
3. In the PIC18+CAN Evaluation Board window, click **Setup Modules**. This command causes multiple CAN messages to be transmitted and initializes all nodes on the board.

The interactive features of the board are now available.

## 4.4.2 PIC18+CAN Evaluation Board Window

As with its counterparts in the other templates, this window displays the current communication status with the board. In this template, there are two control buttons. “Reset Board” resets the firmware and writes power-on default values to all CAN registers. “Setup Modules” initializes the firmware for the interactive (demonstration) mode.

**FIGURE 4-16: PIC18+CAN EVALUATION BOARD WINDOW (EVALUATION BOARD TEMPLATE VERSION)**



## 4.4.3 Node0 Eval Board (Control) Window

This window controls the interactive features on the Node0. Once initialized, this window displays the correct status for the user-defined devices connected to Node0. Node0 has the most interactive features, which means that this control window is the largest of the three. From top to bottom, the controls are:

- **Pot Value:** This indicator is updated in real-time to display the approximate position of the Node0 potentiometer. The value is also displayed in numerical format, ranging from 0 to 1000 (approximately).
- **PWM Intensity:** This indicator shows the output of the PWM module in relative terms, from minimum to maximum. It also shows the value numerically, ranging from 0 to 1000 (approximately); this value is controlled by, and should match that of, the Node1 potentiometer in the Node1 Eval Board window. The relative value should also correspond to the brightness of the ninth LED, which is controlled by the PWM module's output.
- **Push Button Status:** The two indicators (btn0 and btn1) show the status of the node's user-defined push buttons. Pressing the buttons on the board will change the indicators.
- **LED Status:** These eight buttons control and indicate the status of the first 8 LEDs of the LED bank (the ninth LED is controlled by Node1's potentiometer). Clicking on any of the buttons will toggle the corresponding LED on or off. The LED Enable jumper (JP3) must be installed for this feature to work.

# Using the CANKing Templates

- **LCD:** If a compatible LCD display is attached at the header, a message can be written to it by using this area. To send a line of text, type into the “Text” text box (up to 7 characters), then click **Send**. To erase the display, click **Clear**.
- **EEPROM:** The on-board serial EEPROM can be read from and written to from this area. To write, enter a valid address in the “Address” text box, enter data values into one or more of the “Content” boxes, then click **Write**. To read, enter a valid address in “Address”, then click **Read**.

**FIGURE 4-17: NODE0 EVAL BOARD CONTROL WINDOW**

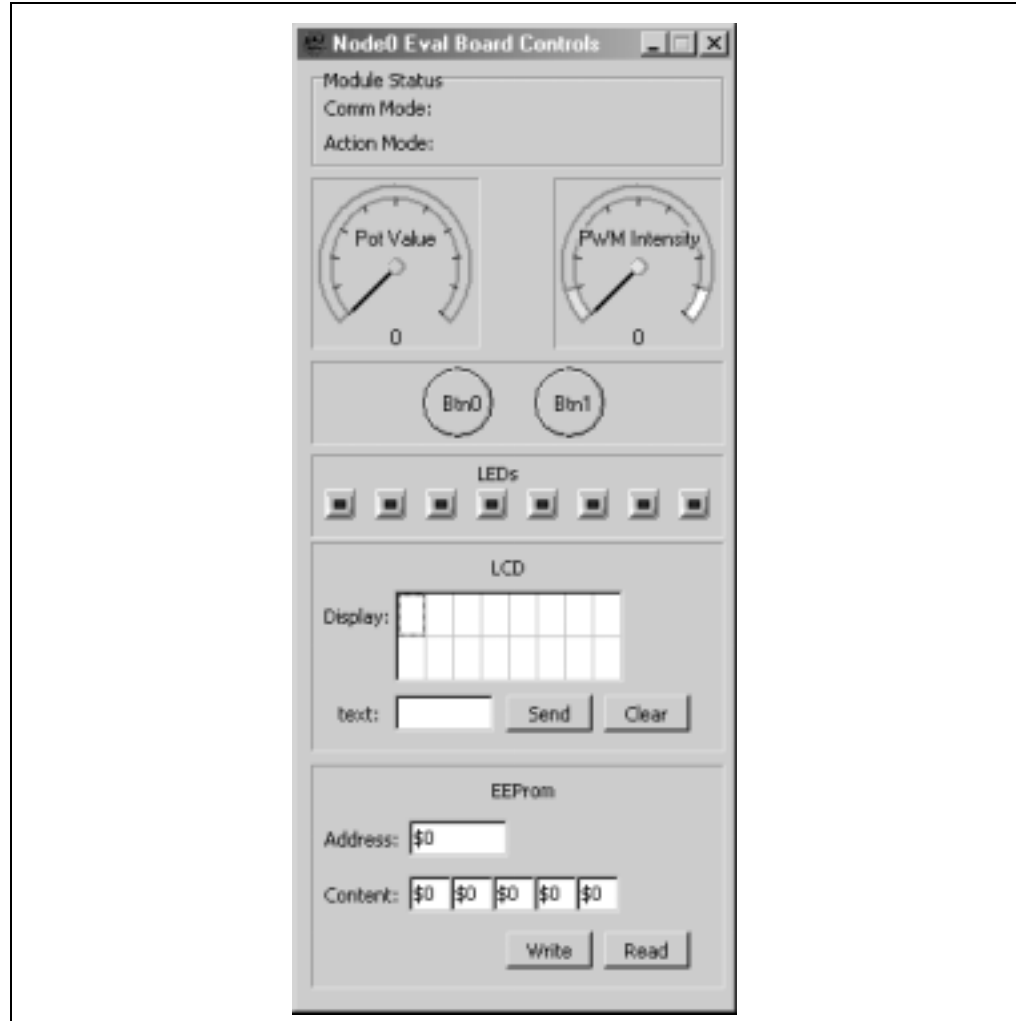

## 4.4.4 Node1 Eval Board (Control) Window

This window controls Node1, the second CAN and LIN master node. When the board is properly initialized, this window will also display the correct "Module Status".

The interactive features are:

- **Pot Value and PWM Intensity:** These function identically to their counterparts for the Node0 Eval Board control window, except these refer to Node1. The PWM intensity displayed and brightness of the ninth LED is controlled by the Node0 potentiometer, the value of which is displayed in the Node0 Eval Board window.
- **Push Button Status:** These are identical in function to Node0.
- **LED Status:** These are also identical to Node0. The LED Enable jumper (JP4) must be installed for this feature to work.

FIGURE 4-18: NODE1 EVAL BOARD CONTROL WINDOW

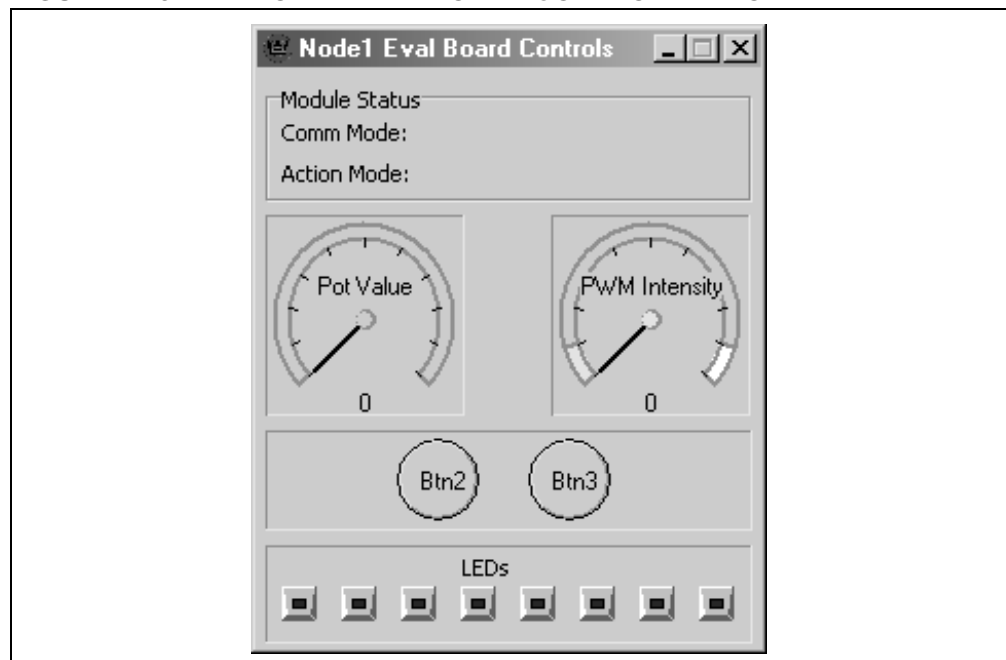

## 4.4.5 Node2 Eval Board (Control) Window

This window shows real-time status of Node2, the LIN slave node.

Its features are:

- **Poll Automatically:** When this check box is selected, the status of the Node2 potentiometer is monitored in real-time and shown on the “Pot Value” display. Like the other nodes, the value is also reported numerically.
- **Count LEDs:** Checking this box causes the Node2 LEDs to count up in binary sequence (Least Significant digit on the left). The LEDs on the board and the Eval window display count synchronously.
- **LED Status:** Like the other nodes, the LEDs for Node2 can also be individually toggled on and off. For this feature (and the “Count LEDs”) to work, the LED Enable jumper (JP4) must be installed.

**FIGURE 4-19: NODE2 EVAL BOARD CONTROL WINDOW**

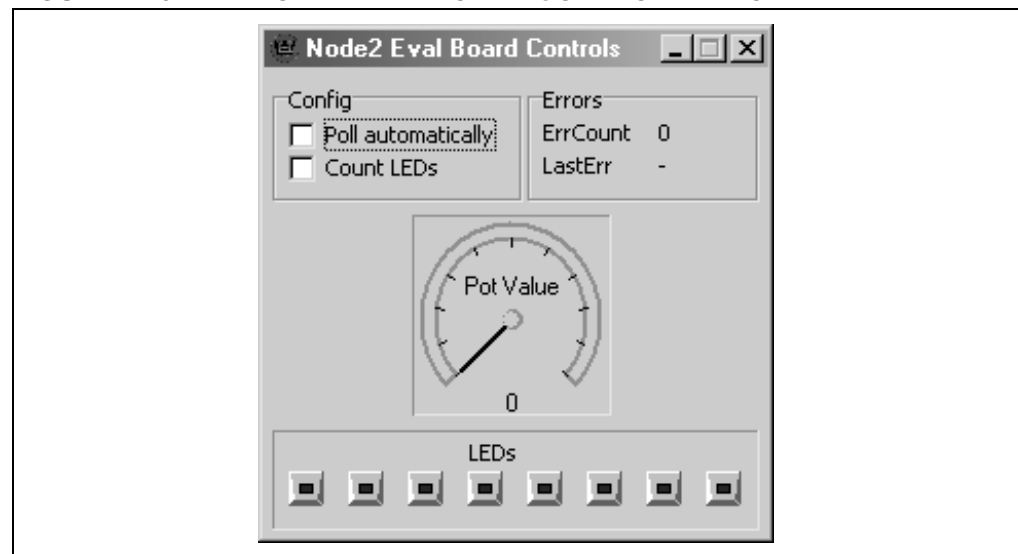

## 4.4.6 PIC18+CAN Controller

This window is identical to the PIC18+CAN Controller window in the Basic Template (Section 4.3.2 “PIC18+CAN Controller”).

## 4.4.7 Select Formatters

This window is identical to the Message Formatters window in the Basic Template (Section 4.3.3 “Select Formatters Window”).

## 4.4.8 History List

This window is identical to the History List window in the Basic Template (Section 4.3.5 “History List”).

## 4.4.9 Timed Transmission

This is identical to in form and function to the Timed Transmission window in the Basic Template (Section 4.3.6 “Timed Transmission”).

## 4.4.10 Output Window

The output window is discussed in Section 3.6 “The Output Window”.

## 4.5 TEMPLATE-SPECIFIC VARIATIONS IN THE MAIN MENU

For the most part, the options available from the CANKing main menu are identical in all three template views. The few exceptions are described below. Only two menu items will be discussed in this section, as the others are self explanatory.

### Messages Menu

In the Basic and PIC18+CAN Evaluation templates, the *Messages* menu selects the CAN message type to be transmitted. Each option opens a dialog box for configuring the message; the dialog is unique to the message type.

Two message options are available: Universal or CAN Kingdom. The *Universal* option allows the user to send standard generic-format messages using a normal (up to eight byte), integer, long integer, 32-bit floating point or string page format. The *CAN Kingdom* option lets the user transmit a message that adheres to the CAN Kingdom higher layer protocol in one of 20 pre-defined King's page formats, or a default letter format.

In the PIC Register template, the Messages menu provides alternate access to the various buffer and register configuration windows; these are available as submenu options from the single menu option (*PIC18+CAN Eval Board*).

### Options Menu

All of the templates offer the *Global* and *PIC18+CAN...* options in the Options menu. These are used to configure communications with the board and global features of CANKing, and are discussed in Section 3.5 "The Main Menu".

The Basic and P Evaluation templates also include the *King's Pages* option. Selecting this allows the user to set a default King's envelope and city/group address.

<p><b>Note:</b> The oscillator frequency must be set in software to match the hardware so the software can configure the bit timing registers correctly. The formulas for bit timing contain a oscillator frequency.</p>
--

The options menu contains the configurable properties of both the hardware and the software.

The default numeric base is selected by *Options > Global*. Auto-save switches are also contained here.

*Options > PIC18+CAN...* is where the COM port is selected, and where the oscillator frequency is set in software. This menu also contains a switch that determines whether or not the Node0 controller will be reset on file open. This feature is for those users who want to switch between templates without changing the PIC18FXX8 configuration (e.g., masks and filters are set to receive ALL messages in the Basic template unless this box is deselected).

---

---

## Chapter 5. Reconfiguring the PICDEM™ CAN-LIN 2 Hardware

---

---

### 5.1 HIGHLIGHTS

This chapter covers the following:

- Node Configurations
- Oscillator Configurations
- Jumper Settings
- Restoring the PICDEM™ CAN LIN 2 Firmware

### 5.2 NODE CONFIGURATIONS

The PICDEM CAN-LIN 2 board can be operated in many different configurations; only a few of the possibilities are listed here. Most of these can be implemented without any changes to the board; some may require the addition of some components or wiring. Access to the external LIN bus will require the addition of a LIN bus connector at the pads provided for J4 (item 16 in Figure 1-1).

#### 5.2.1 Two CAN Nodes, One LIN Node, Embedded System

This is the default configuration. The two CAN nodes (Node0 and Node1) are connected via the on-board CAN bus, while Node1 and Node2 are connected via the on-board LIN bus. There are no external CAN or LIN bus connections.

This configuration can be used for evaluation or development. For design evaluation, use one of the three templates to monitor or control the board. For development, use Node1 for the development of applications; Node0 can then be used with the CANKing software to monitor the development node. If required, Node1 may also communicate with Node2.

#### 5.2.2 Two CAN Nodes, One LIN Node, Distributed System

In this configuration, external CAN and LIN bus devices can be connected to the on-board bus.

This configuration can be used for evaluation or development, using a similar approach as an embedded system configuration (above).

#### 5.2.3 Two CAN Nodes, Embedded System

In this configuration, Node2 is deactivated by removing the PIC16C432 controller from its socket (with the power off, of course). If required, the circuit traces between the Node1 USART pins and the stand-alone LIN bus transceiver may be cut, and an extra RS-232 line driver may be added.

In Development mode, Node0 can be used to monitor Node1.

#### 5.2.4 Two CAN Nodes, Distributed System

This configuration connects both on-board CAN nodes to an external CAN bus.

In Evaluation mode, Node0 can be used to monitor the external bus. In Development mode, Node0 can be used to monitor both Node1 and the external bus.

## 5.3 OSCILLATOR CONFIGURATIONS

The PICDEM CAN-LIN 2 Board is designed to accommodate three different types of oscillators for the PIC18FXX8-based nodes:

- Crystal-controlled oscillator
- RC oscillator
- Self-contained oscillator module (“canned” oscillator)

There are two oscillator sections on the board, one for each of the CAN controllers. As shipped from the factory, the board is configured with two 25 MHz canned oscillators. If a different clock frequency is desired, it is only necessary to remove the existing oscillator modules and insert new ones.

To implement the other options, it will be necessary for users to make changes to the board.

### 5.3.1 Crystal Oscillator

The on-board oscillator module(s) (Y2 and/or Y3) must be removed from their sockets.

Either one (or both) of the CAN controllers can be configured to use a crystal oscillator. Pads Y1 and Y4 (for Node0 and Node1, respectively) have been provided to add a crystal. Depending on frequency and crystal used, capacitors may also need to be added at pads C24/C25 (Node0) and C30/C31 (Node 1). It is the user's responsibility to select values for these components to obtain a frequency compatible with the controller. If the RC oscillator option has been previously used, it will be necessary to remove the RC network components.

### 5.3.2 RC Oscillator

The on-board oscillator module(s) (Y2 and/or Y3) must be removed from their sockets.

The RC network for the oscillator is not provided and must be added by the user. Each CAN controller has pads provided for an RC network. Pads R21/C27 (for Node0) and R22/C29 (for Node1) are provided for the addition of these components. It is the user's responsibility to select values for these components to obtain a frequency compatible with the controller.

## 5.4 JUMPER SETTINGS

There are several jumpers provided for configuring the hardware operation of the PICDEM CAN-LIN 2 board. Their functions are listed in Table 5.1, and locations are shown in Figure 5-2.

**Table 5.1: Jumper Description**

Number	Board ID	Function
1	JP3	Connects 120 ohm terminating resistor to the CAN bus
2	JP1	LED Enable for Node0
3	JP2	LED Enable for Node1
4	JP4	LED Enable for Node2

# Reconfiguring the PICDEM™ CAN-LIN 2 Hardware

FIGURE 5-2: JUMPER LOCATIONS

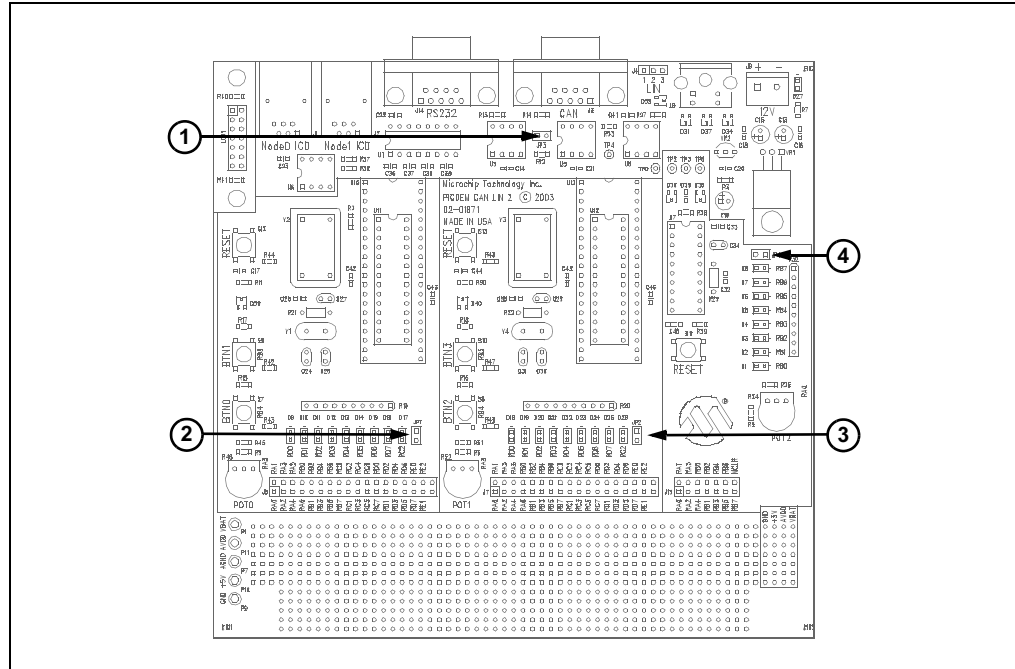

## 5.5 RESTORING THE PICDEM CAN-LIN 2 FIRMWARE

As shipped from the factory, the microcontrollers on the PICDEM CAN-LIN 2 board are preprogrammed with special firmware. This provides the code that makes the interactive Evaluation mode possible and enables communication with the CANKing host software.

As users develop their own CAN applications, it is likely that the controllers will be reprogrammed with new firmware. Should it ever become necessary to return the board to its original state, it will be necessary to restore the original firmware.

To make this process easier, the required source and HEX files for the firmware have been included on the PICDEM CAN-LIN 2 Software CD, in the Firmware folder. To reprogram the microcontrollers directly with the original firmware, use these HEX files:

- **cannode.hex**: for Node0 and Node1 devices (PIC18F458 only)
- **linnode.hex**: for the Node2 device (PIC16C432)

Users should follow the procedure appropriate for their device programmer and development environment.

**Note:** The PIC18 CAN-based firmware included with the PICDEM™ CAN-LIN 2 Development Kit has been specifically designed for use with the PIC18F458 microcontroller *only*. Substituting other devices from the PIC18FXX8 family means that the PICDEM™ CAN-LIN 2 board cannot be used with the CANKing software.

# PICDEM™ CAN-LIN 2 User's Guide

---

---

NOTES:

---

---

## Chapter 6. Troubleshooting

---

---

### 6.1 HIGHLIGHTS

This chapter discusses the following:

- Common issues with the PICDEM™ CAN-LIN 2 Board and how to solve them.

### 6.2 COMMON PROBLEMS

#### 1. The Power LED is not lit

Check the PICDEM CAN-LIN 2 board for power:

- Verify that the power supply is plugged in and the wall outlet has power. If battery connection is used, verify that the correct polarity is used.
- Check that voltage is available (12VDC) at the plug. If the original power supply is not being used, check for appropriate voltage (12VDC).
- Check that the regulated voltage (5VDC) is available at the connectors at the prototype area of the board.

#### 2. The host software cannot communicate with the board

Check that the board is receiving power (see issue 1 above).

Check the serial cable for proper connections to the board and the computer. Verify that the cable is connected to the correct serial port on the computer. If necessary, verify the serial cable by swapping in another cable that is known to be good.

Verify through Windows Device Manager (accessed through the System applet in the Control Panel) that the selected COM port is recognized by the operating system and is working.

Verify that you are using the correct serial port. Check that the COM port you have selected in the terminal software is actually the physical port that the serial cable is connected to.

Verify that the Node0 LEDs flash briefly on RESET or power-up of the board.

If you are using the optional LCD module, verify that the text "PIC CAN" is briefly displayed on RESET or power-up, and an underscore cursor is displayed.

#### 3. The board is operational, but neither of the CAN nodes are recognized on an external network.

See Appendix B ("FAQs on Configuring the PIC18FXX8") for the most common CAN troubleshooting hints.

# PICDEM™ CAN-LIN 2 User's Guide

---

---

NOTES:

**Appendix A. PICDEM™ CAN-LIN 2 Board Technical Information**

**A.1 HIGHLIGHTS**

This chapter will cover the following topics:

- PICDEM™ CAN-LIN 2 Block Diagram
- PICDEM CAN-LIN 2 Board Schematics

**A.2 BLOCK DIAGRAM**

**FIGURE A-1: PICDEM CAN-LIN 2 DEVELOPMENT BOARD FUNCTIONAL BLOCK DIAGRAM**

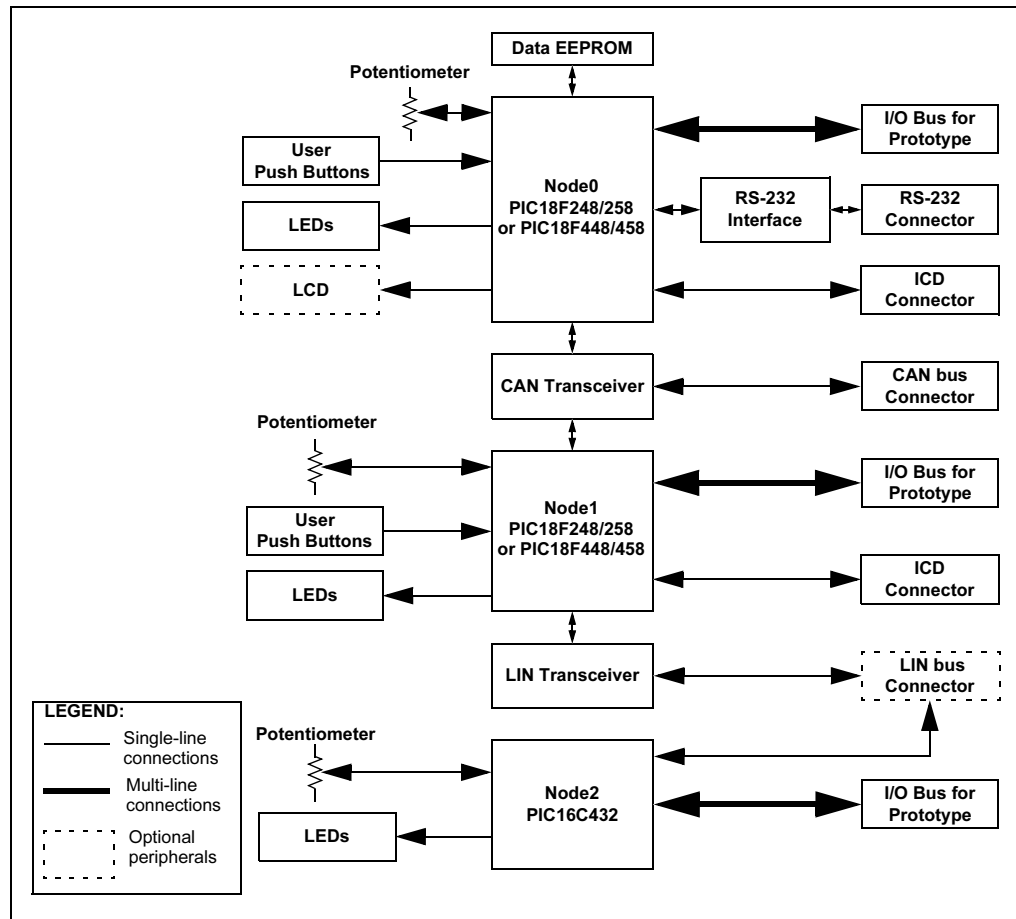

## A.3 PICDEM CAN-LIN 2 BOARD SCHEMATICS

FIGURE A-2: BOARD SCHEMATIC, PART 1 (NODE0 MICROCONTROLLERS AND ASSOCIATED PARTS)

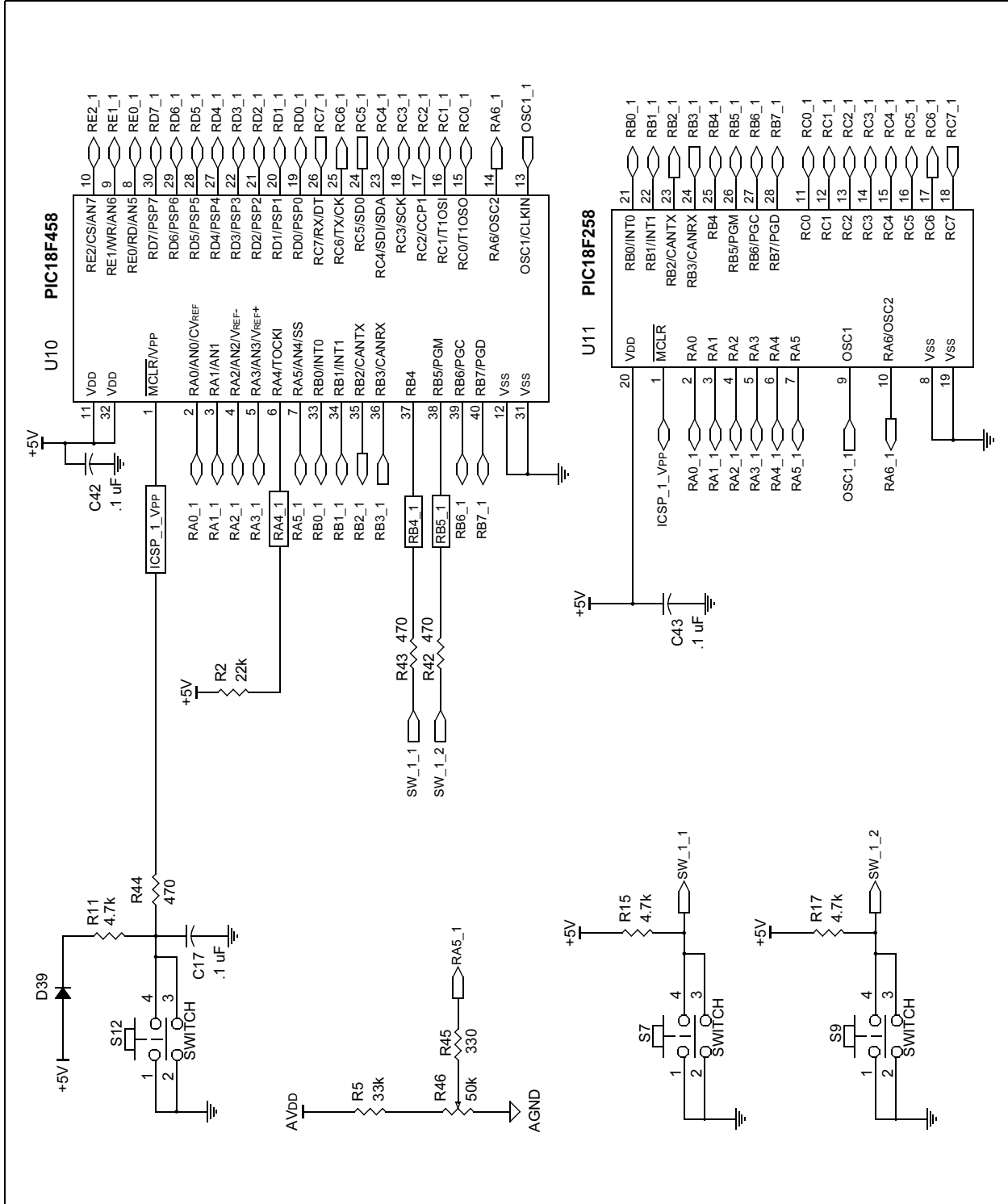

# PICDEM™ CAN-LIN 2 Board Technical Information

**FIGURE A-3: BOARD SCHEMATIC, PART 2 (NODE1 MICROCONTROLLERS AND ASSOCIATED PARTS)**

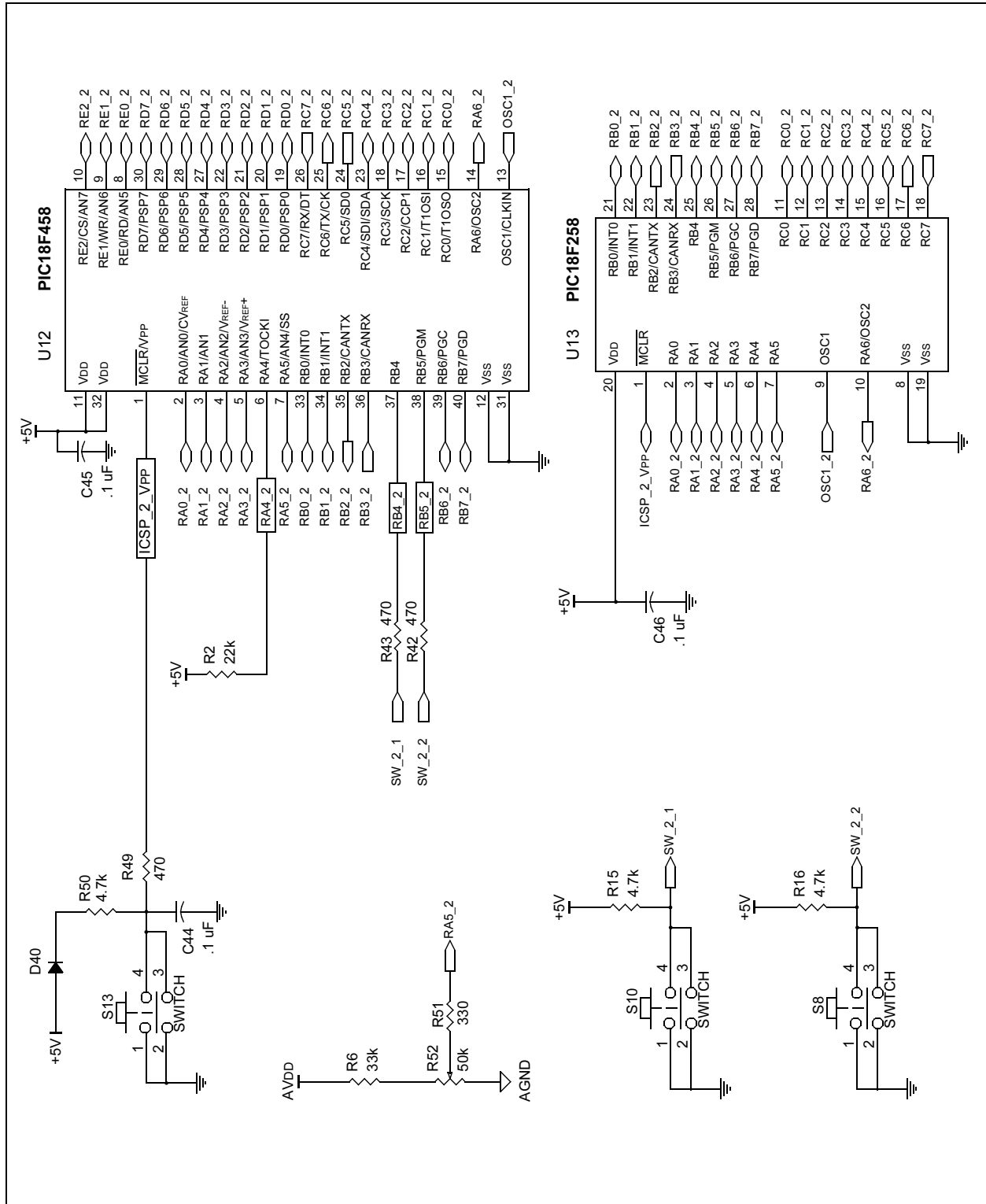

# PICDEM™ CAN-LIN 2 User's Guide

**FIGURE A-4: BOARD SCHEMATIC, PART 3 (NODE2 MICROCONTROLLER, LIN AND CAN TRANSCEIVERS, EEPROM)**

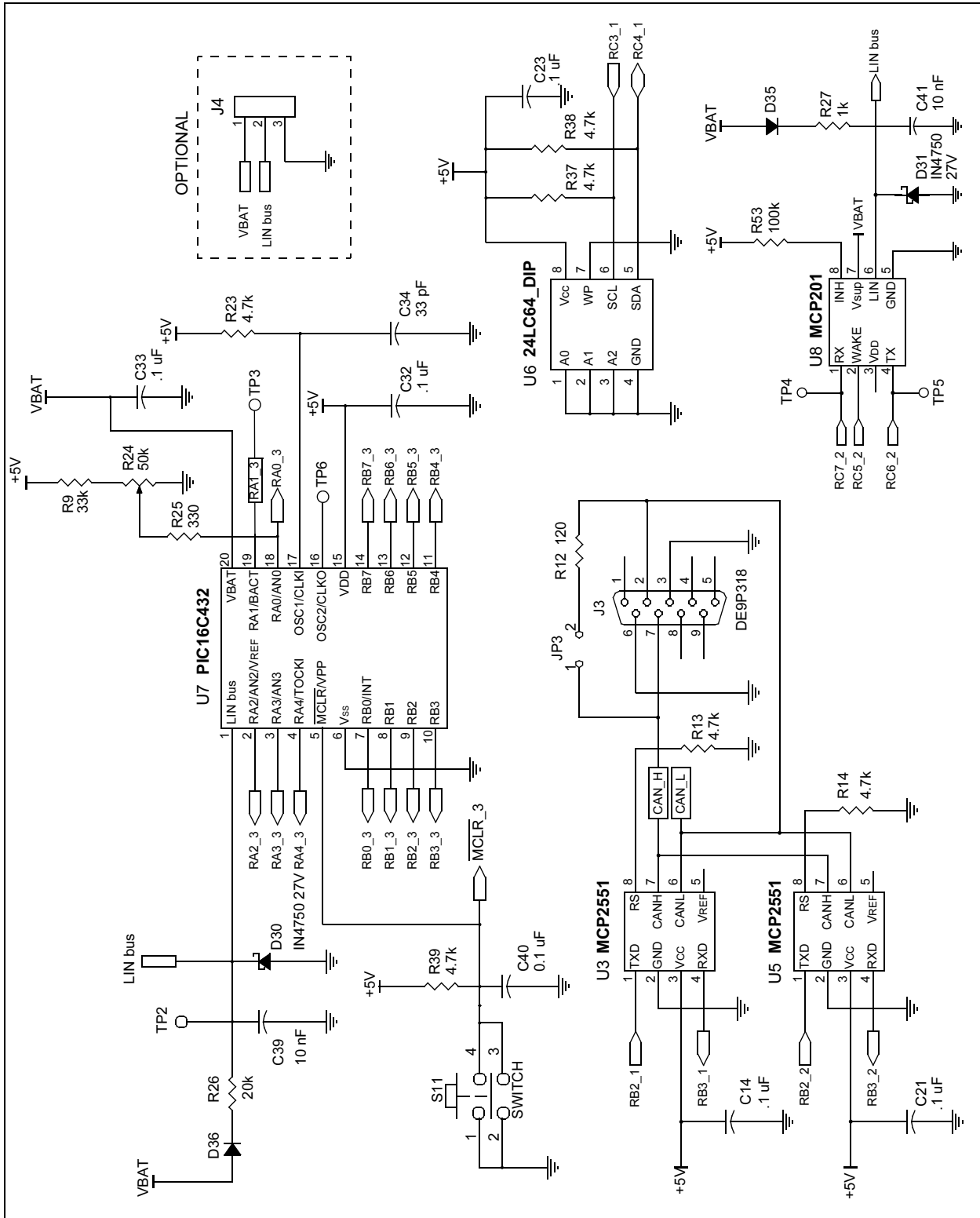

# PICDEM™ CAN-LIN 2 Board Technical Information

FIGURE A-5: BOARD SCHEMATIC, PART 4 (USART, OSCILLATOR OPTIONS AND POWER SUPPLY)

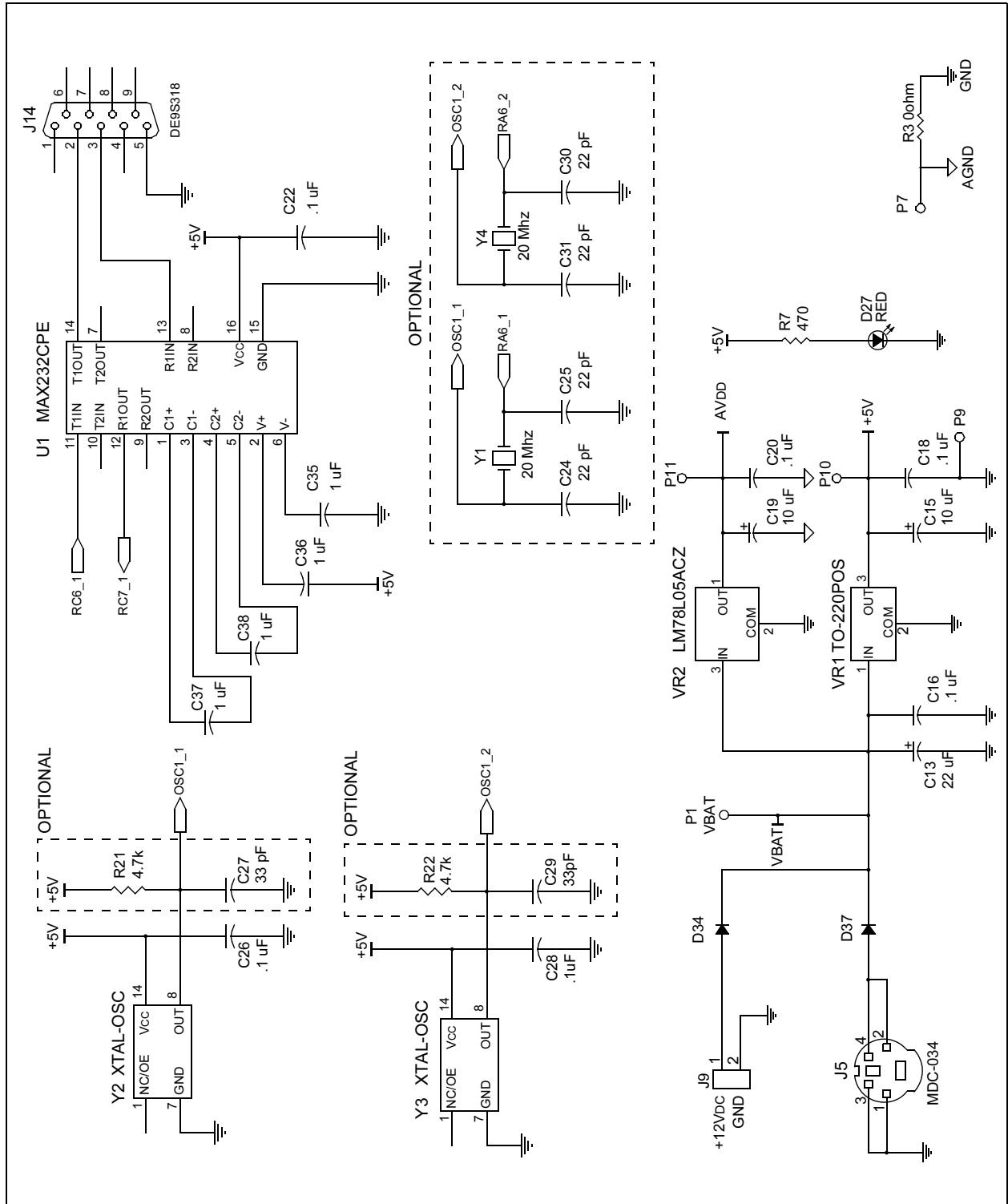

# PICDEM™ CAN-LIN 2 User's Guide

FIGURE A-6: BOARD SCHEMATIC, PART 5 (LEDS AND LCD DISPLAY OPTION)

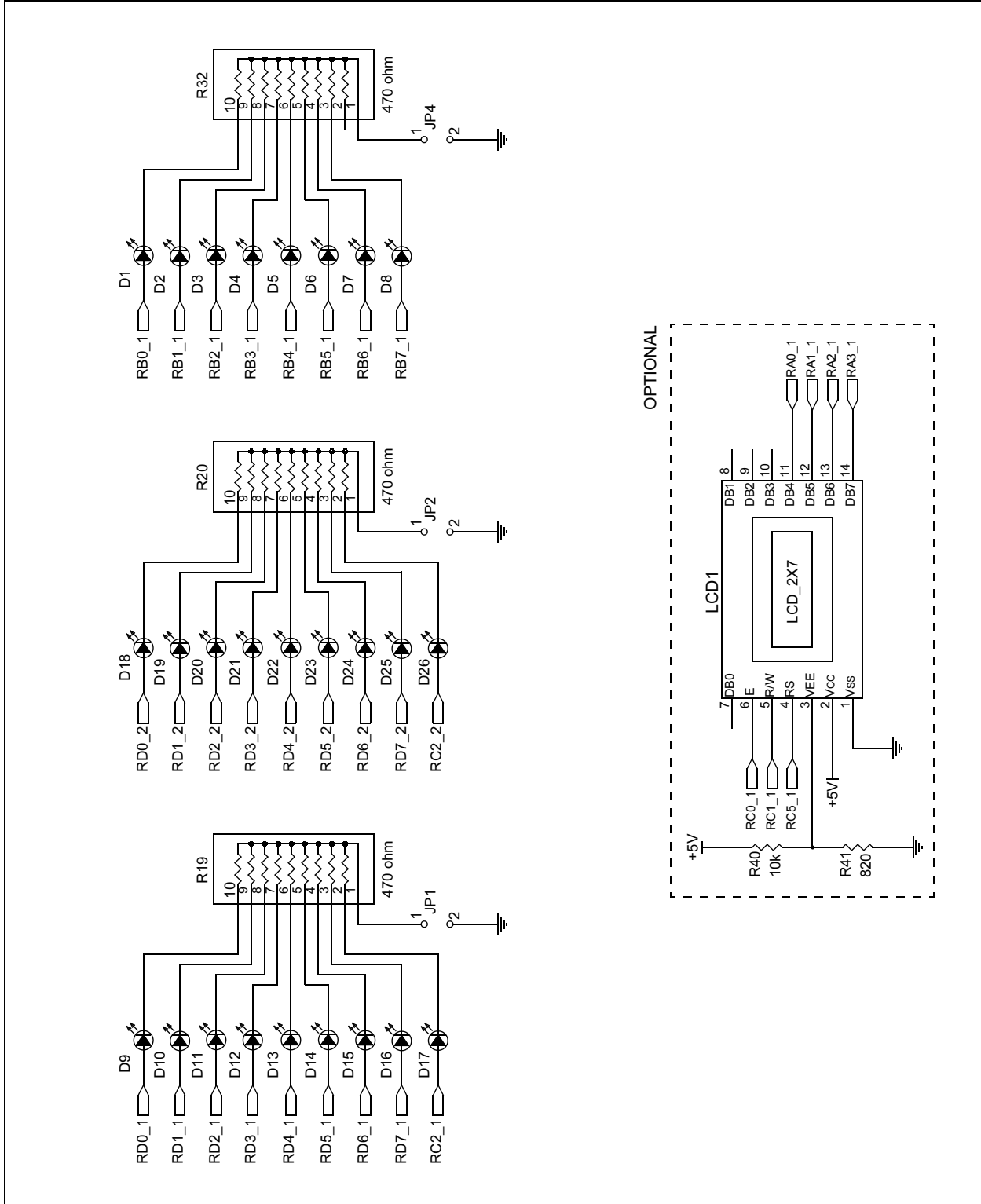

# PICDEM™ CAN-LIN 2 Board Technical Information

FIGURE A-7: BOARD SCHEMATIC, PART 6 (PROTOTYPE HEADERS AND CONNECTORS)

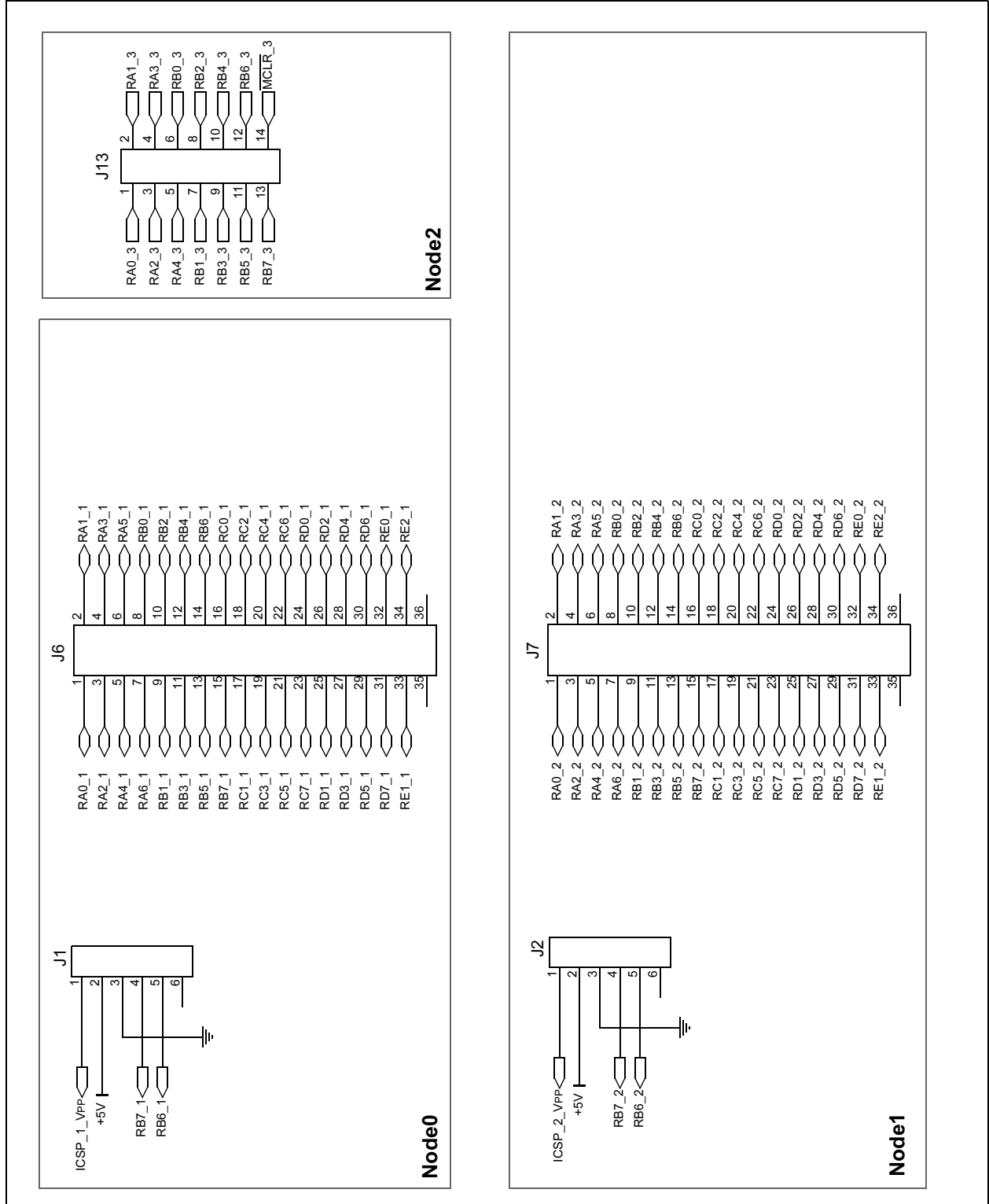

**TABLE A-1: SIGNALS USED IN THE PICDEM CAN LIN 1 SCHEMATIC**

Signal Name	Function
CAN_H, CAN_L	Differential high and low CAN bus signals
ICSP_1_VPP or ICSP_2_VPP	ICSP™ programming voltage and RESET for the designated controller: 1 – CAN Node0 2 – CAN Node1
LIN bus	Differential LIN bus signal
MCLR_3	RESET signal for LIN Node (PIC16C432)
SW_1_n or SW_2_n	Push button input from switch n for the designated controller: 1 – CAN Node0 2 – CAN Node1
RXn_1, RXn_2 or RXn_3	Bit n of Port X for the designated controller: 1 – CAN Node0 2 – CAN Node1 3 – LIN Node (PIC16C432)
VBAT	LIN bus battery voltage (+9 to +12 VDC)

**TABLE A-2: LCD CONTROLLER HEADER**

Pin	Signal	Pin	Signal
1	GND	2	+5V
3	VEE	4	RS
5	R/W	6	E
7	NC	8	NC
9	NC	10	NC
11	DB4	12	DB5
13	DB6	14	DB7

## Appendix B. FAQs on Configuring the PIC18FXX8

### B.1 HIGHLIGHTS

This section discusses some of the most frequently asked questions (FAQs) on configuring and programming PIC18FXX8 microcontrollers.

### B.2 FAQs

**Q: Why doesn't the development tool successfully communicate on an external bus?**

A: There are several possible reasons why this happens. The following are the most common problems:

Condition	Fix
The PIC18FXX8 is off the bus (not in Normal mode).	Basic template – “Go on Bus” button in the “Bus Status” window.
The COM port is not configured correctly.	Make sure COM port selection is correct ( <i>Options &gt; PIC18+CAN...</i> ).
The bus rate is not set to match the bus.	Basic template – Set the bus rate in the Bus Status window. Register template – change BRGCON registers.
The oscillator frequency not set to match hardware (Fosc is required in bit rate formula).	Set the oscillator frequency ( <i>Options &gt; PIC18+CAN...</i> ).
Board is not connected to the external bus.	Connect to the external bus using the DB9 labeled CAN. Pinouts: CANH - pin 7, CANL - pin2.

**Q: Why does the node acknowledge messages in the Basic template, but not display them?**

A: The PIC18FXX8 filters are not matching the incoming messages. This can be caused because the “Reset PIC18+CAN on Open” is deselected causing the old register contents (masks and filters) to remain unchanged when switching templates.

Press RESET or select the “Reset PIC18+CAN on Open” box and reopen the template.

**Q: Why can't I enter values in the Physical Layer window?**

A: The PIC18FXX8 is not in Configuration mode. The three BRGCON registers are only modifiable while in Configuration mode. Change modes.

**Q: Why don't the mask and filter registers change after pressing the Write button?**

A: The PIC18FXX8 is not in Configuration mode. Masks and filters are changeable only in Configuration mode.

**Q: How do I enter extended IDs into a field?**

A: Lead off the number with an 'x', which indicates an extended frame (e.g., x12345).

---

---

**Appendix C. PICDEM™ CAN-LIN 2 Software CD**

---

---

**C.1 HIGHLIGHTS**

This chapter summarizes the contents of the PICDEM™ CAN-LIN 2 Software CD-ROM.

**C.2 WHAT'S ON THE CD**

The PICDEM CAN-LIN 2 CD includes the following software tools and support documentation.

**CANKing Host Software**

The entire utility is contained in the self-extracting installer file `wc32mchip_pic.exe`. Executing this file will install the CANKing software described in Chapter 3, and the pre-defined templates covered in Chapter 4.

**PICDEM CAN-LIN 2 Firmware**

The firmware for the Demonstration Board's microcontrollers are located in the Firmware folder. The device-specific files are located in the subfolders CANNode (for PIC18F458 devices) and LINNode (for PIC16C432). In addition to the HEX files for device programming, assembler and C language source files are provided for creating custom projects.

All necessary project, header and linker files are also included, so that users with MPLAB may begin to create custom projects immediately.

**Note:** The MPLAB Integrated Development software is not included with the PICDEM CAN-LIN 2 Kit. Users who do not have MPLAB may download it without charge from the Microchip web site ([www.microchip.com](http://www.microchip.com)).

**Support Files for Microchip PICmicro Microcontrollers with CAN**

Also provided is a complete library of support information for Microchip's line of microcontrollers with CAN functionality. This includes:

- The latest data sheet for the PIC18FXX8 family of microcontrollers;
- The In-Circuit Serial Programming™ specification for the PIC18FXX8 family;
- Application Note 738, "PIC18C CAN Routines in 'C'", which presents a library of CAN functions;
- Application Note 853, "PIC18CXX8 CAN Driver with Prioritized Transmit Buffer", which provides an assembler-based firmware driver for a CAN node; and
- Sales and support literature for the PIC18FXX8 family.

The application notes are provided with a complete set of the source code files discussed in each document, allowing the user to begin working with the CAN utilities immediately.

**PICDEM™ CAN-LIN 2 User's Guide**

This single file is the electronic version of this Development Kit manual, provided in Adobe® Acrobat® format.

# PICDEM™ CAN-LIN 2 User's Guide

---

---

NOTES:

## Index

### C

CAN Controller Window .....	32, 39
CAN Kingdom Protocol .....	12
CANKing Host Software .....	12, 14, 16, 21, 41, 57
Customizing Projects in .....	24
Installation .....	14
Main Menu .....	22
Output Window .....	23, 33, 39
Templates .....	25–40
Connectors	
CAN (DB9M) .....	11
ICSP (pads for) .....	11
LCD Header .....	12
LIN (pad for) .....	11
Power .....	11
Serial (DB9F) .....	11
Customer Support .....	4

### D

Document Layout .....	1
Documentation	
Conventions .....	2
Layout .....	1
Numbering Conventions .....	3
Updates .....	2

### E

EEPROM, External .....	9, 11, 37
Evaluation Board Window	
Basic Template .....	31
PIC Register Template .....	26
PIC18+CAN Evaluation Board Template .....	36

### H

Hardware Configuration	
Jumper Settings .....	42
Oscillators .....	42
History List Window .....	34, 39
Hooking Up the Board .....	14
Host Computer Requirements .....	13

### K

Kvaser AB .....	12
-----------------	----

### L

LCD Display .....	9, 12, 37, 45, 52
Pinout for Header .....	54

### LEDs

Count LEDs (Node2) .....	39
Digital Port .....	11, 15, 19, 36, 38, 39, 42, 45

Power .....	11, 15, 45
PWM-Driven .....	11, 19, 36, 38

### M

Message Filter Window .....	26
Message Formatters Window .....	33, 39

### N

Node Configurations .....	41
Node0 .8, 10, 22, 23, 25, 26, 27, 30, 36, 41, 42, 48	
Node0 Eval Board (Control) Window .....	36
Node1 .....	8, 10, 22, 30, 36, 38, 41, 49
Node1 Eval Board (Control) Window .....	38
Node2 .....	8, 9, 10, 11, 19, 39, 41, 50
Node2 Eval Board (Control) Window .....	39

### O

Oscillators .....	10
Configuring .....	42

### P

Physical Layer Window .....	27
PIC16C432 .....	7, 8, 10, 41, 47, 54
PIC18+CAN Configuration Window .....	30
PIC18+CAN Status Window .....	28
PIC18C+CAN Configuration Window .....	30
PIC18F248/258 .....	8
PIC18F448/458 .....	8
PIC18FXX8 .....	30, 47
PICDEM CAN-LIN 2 Board	
Block Diagram .....	47
Jumper Locations .....	43
Schematics .....	48–53
Signals in Schematic (table) .....	54
PICDEM CAN-LIN 2 Software CD	
Contents .....	57
Potentiometers, User-Defined .....	11, 19, 36, 38
Prototype Area .....	12
Prototype Headers (pads for) .....	12
Pushbuttons	
Reset .....	10
User-Defined .....	10, 36, 38, 54
Putting the Board in Evaluation Mode .....	35

### R

Receive Buffer Window .....	28
References .....	3

### S

Select Formatters Window .....	33, 39
--------------------------------	--------

# PICDEM™ CAN-LIN 2 User's Guide

---

Serial port .....	15
Support	
Customer .....	4

## T

Template Windows and Dialog Boxes	
CAN Controller Window .....	32, 39
Evaluation Board Window	
Basic Template .....	31
PIC Register Template .....	26
PIC18+CAN Evaluation Template .....	36
History List Window .....	34, 39
Message Filter Window .....	26
Message Formatters Window .....	33, 39
Node0 Eval Board (Control) Window .....	36
Node1 Eval Board (Control) Window .....	38
Node2 Eval Board (Control) Window .....	39
Output Window .....	33, 39
Physical Layer Window .....	27
PIC18+CAN Configuration Window .....	30
PIC18+CAN Status Window .....	28
Receive Buffer Window .....	28
Timed Transmission Window .....	34, 39
Transmit Buffer Window .....	29
Templates	
Basic .....	30
PIC Register View .....	25
PIC18+CAN Evaluation Board .....	35
Variations in the Main Menu .....	40
Timed Transmission Window .....	34, 39
Transmit Buffer Window .....	29
Troubleshooting .....	4

NOTES:



# MICROCHIP

## WORLDWIDE SALES AND SERVICE

### AMERICAS

#### Corporate Office

2355 West Chandler Blvd.  
Chandler, AZ 85224-6199  
Tel: 480-792-7200 Fax: 480-792-7277  
Technical Support: 480-792-7627  
Web Address: <http://www.microchip.com>

#### Rocky Mountain

2355 West Chandler Blvd.  
Chandler, AZ 85224-6199  
Tel: 480-792-7966 Fax: 480-792-4338

#### Atlanta

3780 Mansell Road, Suite 130  
Alpharetta, GA 30022  
Tel: 770-640-0034 Fax: 770-640-0307

#### Boston

2 Lan Drive, Suite 120  
Westford, MA 01886  
Tel: 978-692-3848 Fax: 978-692-3821

#### Chicago

333 Pierce Road, Suite 180  
Itasca, IL 60143  
Tel: 630-285-0071 Fax: 630-285-0075

#### Dallas

4570 Westgrove Drive, Suite 160  
Addison, TX 75001  
Tel: 972-818-7423 Fax: 972-818-2924

#### Detroit

Tri-Atria Office Building  
32255 Northwestern Highway, Suite 190  
Farmington Hills, MI 48334  
Tel: 248-538-2250 Fax: 248-538-2260

#### Kokomo

2767 S. Albright Road  
Kokomo, Indiana 46902  
Tel: 765-864-8360 Fax: 765-864-8387

#### Los Angeles

18201 Von Karman, Suite 1090  
Irvine, CA 92612  
Tel: 949-263-1888 Fax: 949-263-1338

#### San Jose

Microchip Technology Inc.  
2107 North First Street, Suite 590  
San Jose, CA 95131  
Tel: 408-436-7950 Fax: 408-436-7955

#### Toronto

6285 Northam Drive, Suite 108  
Mississauga, Ontario L4V 1X5, Canada  
Tel: 905-673-0699 Fax: 905-673-6509

### ASIA/PACIFIC

#### Australia

Microchip Technology Australia Pty Ltd  
Marketing Support Division  
Suite 22, 41 Rawson Street  
Epping 2121, NSW  
Australia  
Tel: 61-2-9868-6733 Fax: 61-2-9868-6755

#### China - Beijing

Microchip Technology Consulting (Shanghai)  
Co., Ltd., Beijing Liaison Office  
Unit 915  
Bei Hai Wan Tai Bldg.  
No. 6 Chaoyangmen Beidajie  
Beijing, 100027, No. China  
Tel: 86-10-85282100 Fax: 86-10-85282104

#### China - Chengdu

Microchip Technology Consulting (Shanghai)  
Co., Ltd., Chengdu Liaison Office  
Rm. 2401-2402, 24th Floor,  
Ming Xing Financial Tower  
No. 88 TIDU Street  
Chengdu 610016, China  
Tel: 86-28-86766200 Fax: 86-28-86766599

#### China - Fuzhou

Microchip Technology Consulting (Shanghai)  
Co., Ltd., Fuzhou Liaison Office  
Unit 28F, World Trade Plaza  
No. 71 Wusi Road  
Fuzhou 350001, China  
Tel: 86-591-7503506 Fax: 86-591-7503521

#### China - Hong Kong SAR

Microchip Technology Hongkong Ltd.  
Unit 901-6, Tower 2, Metroplaza  
223 Hing Fong Road  
Kwai Fong, N.T., Hong Kong  
Tel: 852-2401-1200 Fax: 852-2401-3431

#### China - Shanghai

Microchip Technology Consulting (Shanghai)  
Co., Ltd.  
Room 701, Bldg. B  
Far East International Plaza  
No. 317 Xian Xia Road  
Shanghai, 200051  
Tel: 86-21-6275-5700 Fax: 86-21-6275-5060

#### China - Shenzhen

Microchip Technology Consulting (Shanghai)  
Co., Ltd., Shenzhen Liaison Office  
Rm. 1812, 18/F, Building A, United Plaza  
No. 5022 Binhe Road, Futian District  
Shenzhen 518033, China  
Tel: 86-755-82901380 Fax: 86-755-82966626

#### China - Qingdao

Rm. B505A, Fullhope Plaza,  
No. 12 Hong Kong Central Rd.  
Qingdao 266071, China  
Tel: 86-532-5027355 Fax: 86-532-5027205

#### India

Microchip Technology Inc.  
India Liaison Office  
Marketing Support Division  
Divyasree Chambers  
1 Floor, Wing A (A3/A4)  
No. 11, O'Shaughnessey Road  
Bangalore, 560 025, India  
Tel: 91-80-2290061 Fax: 91-80-2290062

### Japan

Microchip Technology Japan K.K.  
Benex S-1 6F  
3-18-20, Shinyokohama  
Kohoku-Ku, Yokohama-shi  
Kanagawa, 222-0033, Japan  
Tel: 81-45-471-6166 Fax: 81-45-471-6122

### Korea

Microchip Technology Korea  
168-1, Youngbo Bldg. 3 Floor  
Samsung-Dong, Kangnam-Ku  
Seoul, Korea 135-882  
Tel: 82-2-554-7200 Fax: 82-2-558-5934

### Singapore

Microchip Technology Singapore Pte Ltd.  
200 Middle Road  
#07-02 Prime Centre  
Singapore, 188980  
Tel: 65-6334-8870 Fax: 65-6334-8850

### Taiwan

Microchip Technology (Barbados) Inc.,  
Taiwan Branch  
11F-3, No. 207  
Tung Hua North Road  
Taipei, 105, Taiwan  
Tel: 886-2-2717-7175 Fax: 886-2-2545-0139

### EUROPE

#### Austria

Microchip Technology Austria GmbH  
Durisolstrasse 2  
A-4600 Wels  
Austria  
Tel: 43-7242-2244-399  
Fax: 43-7242-2244-393

#### Denmark

Microchip Technology Nordic ApS  
Regus Business Centre  
Lautrup høj 1-3  
Ballerup DK-2750 Denmark  
Tel: 45 4420 9895 Fax: 45 4420 9910

#### France

Microchip Technology SARL  
Parc d'Activite du Moulin de Massy  
43 Rue du Saule Trapu  
Batiment A - 1er Etage  
91300 Massy, France  
Tel: 33-1-69-53-63-20 Fax: 33-1-69-30-90-79

#### Germany

Microchip Technology GmbH  
Steinheilstrasse 10  
D-85737 Ismaning, Germany  
Tel: 49-089-627-144-100  
Fax: 49-089-627-144-44

#### Italy

Microchip Technology SRL  
Via Quasimodo, 12  
20025 Legnano (MI)  
Milan, Italy  
Tel: 39-0331-742611 Fax: 39-0331-466781

#### United Kingdom

Microchip Ltd.  
505 Eskdale Road  
Winnersh Triangle  
Wokingham  
Berkshire, England RG41 5TU  
Tel: 44 118 921 5869 Fax: 44-118 921-5820

02/12/03