

# PSR-MC50

PL  
EN ISO 13849

SILCL  
IEC 62061



## Safety relays for monitoring non-equivalent signal generators

Data sheet  
106176\_en\_01

© PHOENIX CONTACT 2015-05-19

### 1 Description

#### Intended Use

The **PSR-MC50** safety relay can be used to monitor two-channel non-equivalent signal generators, e.g., magnetic switches, as well as to control actuators.

The safety relay is equipped with three enabling current paths that drop out without delay corresponding to stop category 0 according to EN 60204-1.

The enabling current paths are controlled as an automatic or manual, monitored start once sensor circuit channel 1 has been closed and channel 2 has been opened.

With the manual, monitored reset device, a machine start may not be triggered in accordance with EN ISO 13849-1.

#### Features

- Safety relays for monitoring non-equivalent signal generators, e.g., magnetic switches
- Suitable up to category 4, PL e (EN ISO 13849-1), SILCL 3 (EN 62061)
- 1 two-channel non-equivalent sensor circuit
- 3 undelayed enabling current paths
- 1 digital signal output
- Option of screw or spring-cage terminal blocks for plug-in
- 12.5 mm housing width



#### **WARNING: Risk of electric shock**

Observe the safety instructions in the corresponding section!



Make sure you always use the latest documentation.  
It can be downloaded from the product at [phoenixcontact.net/products](http://phoenixcontact.net/products).



This data sheet meets the same requirements as the original operating instructions in terms of contents and is valid for all products listed on the following pages.

---

<b>2</b>	<b>Table of contents</b>	
1	Description .....	1
2	Table of contents .....	2
3	Ordering data .....	3
4	Technical data .....	3
5	Safety notes.....	6
6	Basic circuit diagram .....	7
7	Derating.....	7
	7.1 Vertical or horizontal mounting position .....	7
8	Load curve.....	7
	8.1 Ohmic load .....	7
9	Function/time diagrams .....	8
	9.1 Time diagram for automatic start .....	8
	9.2 Time diagram for manual, monitored start .....	8
10	Operating and indication elements .....	9
	10.1 Connection versions .....	9
	10.2 Connection assignment.....	9
11	Mounting and connection .....	10
12	Startup.....	10
13	Calculating the power dissipation .....	11
14	Diagnostics.....	12
	14.1 General states .....	12
	14.2 Error Messages.....	12
15	Application examples .....	14
	15.1 Magnetic switch monitoring/automatic start .....	14
	15.2 Magnetic switch monitoring/manual, monitored start.....	14
	15.3 Safety door monitoring/automatic start .....	15
	15.4 Safety door monitoring/manual, monitored start.....	15
16	Revision history .....	16

### 3 Ordering data

Description	Type	Order No.	Pcs. / Pkt.
Safety relay for monitoring non-equivalent signal generators up to SIL 3, SILCL 3, Cat. 4, PL e, 2-channel, non-equivalent operation, automatic or manual, monitored start, 3 enabling current paths, $U_S = 24$ V DC, plug-in screw terminal block	PSR-MC50-3NO-1DO-24DC-SC	2700553	1
Safety relay for monitoring non-equivalent signal generators up to SIL 3, SILCL 3, Cat. 4, PL e, 2-channel, non-equivalent operation, automatic or manual, monitored start, 3 enabling current paths, $U_S = 24$ V DC, plug-in spring-cage terminal block	PSR-MC50-3NO-1DO-24DC-SP	2700564	1

### 4 Technical data

Hardware/firmware version	
HW/FW	$\geq 00/-$ (The technical data and safety characteristics are valid as of the specified HW/FW version.)
Input data	
Rated control supply voltage $U_S$	24 V DC -15 % / +10 %
Rated control supply current $I_S$	typ. 80 mA
Typical inrush current	5 A ( $\Delta t = 200 \mu s$ at $U_S$ ) < 20 mA (with $U_S/I_x$ to S12) < 200 mA (with $U_S/I_x$ to S34) < 5 mA (with $U_S/I_x$ to S13)
Current consumption	< 5 mA (with $U_S/I_x$ to S12) < 5 mA (with $U_S/I_x$ to S13) > -5 mA (with $U_S/I_x$ to S34) < 10 mA (with $U_S/I_x$ to S34)
Power consumption at $U_S$	typ. 1.92 W
Voltage at input/start and feedback circuit	24 V DC -15 % / +10 %
Filter time	1 ms (at A1 in the event of voltage dips at $U_S$ ) max. 1.5 ms (at S12, S13; test pulse width) min. 7.5 ms (at S12, S13; test pulse rate) Test pulse rate = 5 x Test pulse width
Max. permissible overall conductor resistance (Input and reset circuit at $U_S$ )	150 $\Omega$
Typical response time at $U_S$	< 175 ms (automatic start) < 175 ms (manual, monitored start)
Typical starting time with $U_S$	< 250 ms (when controlled via A1)
Typical release time with $U_S$	< 20 ms (when controlled via A1 or S12 and S13.)
Recovery time	< 500 ms
Maximum switching frequency	0.5 Hz
Operating voltage display	1 x green LED
Status display	3 x green LED
Protective circuit	Surge protection Suppressor diode Reverse polarity protection for rated control supply voltage
Output data	
Contact type	3 enabling current paths
Contact material	AgSnO <sub>2</sub>
Minimum switching voltage	20 V AC/DC
Maximum switching voltage	250 V AC/DC
Limiting continuous current	6 A (N/O contact)
Maximum inrush current	6 A

**Output data**

Inrush current, minimum	3 mA
Sq. Total current	48 A <sup>2</sup> (see to derating)
Switching capacity min.	60 mW
Mechanical service life	10 x 10 <sup>6</sup> cycles
Output fuse	6 A gL/gG (N/O contact) 4 A gL/gG (for low-demand applications)

**Alarm outputs**

Number of outputs	1 (digital, PNP)
Voltage	22 V DC (U <sub>S</sub> - 2 V)
Current	max. 100 mA
Maximum inrush current	500 mA ( $\Delta t = 1 \text{ ms}$ at U <sub>S</sub> )
Short-circuit protection	no

**General data**

Relay type	Electromechanically forcibly guided, dust-proof relay.
Nominal operating mode	100% operating factor
Degree of protection	IP20
Min. degree of protection of inst. location	IP54
Mounting type	DIN rail mounting
Mounting position	vertical or horizontal
Assembly instructions	See derating curve
Type of housing	PBT yellow
Clearances and creepage distances between the power circuits	DIN EN 50178
Rated insulation voltage	250 V AC
Rated surge voltage/insulation	Safe isolation, reinforced insulation 6 kV between input circuit and enabling current path (13/14) and enabling current path (23/24) and enabling current path (33/34) Basic insulation 4 kV between all current paths and housing
Pollution degree	2
Surge voltage category	III

**Dimensions**

	<b>Screw connection</b>	<b>Spring-cage connection</b>
W x H x D	12.5 x 112.2 x 114.5 mm	12.5 x 116.6 x 114.5 mm

**Connection data**

	<b>Screw connection</b>	<b>Spring-cage connection</b>
Conductor cross section, solid	0.2 mm <sup>2</sup> ... 2.5 mm <sup>2</sup>	0.2 mm <sup>2</sup> ... 1.5 mm <sup>2</sup>
Conductor cross section, stranded	0.2 mm <sup>2</sup> ... 2.5 mm <sup>2</sup>	0.2 mm <sup>2</sup> ... 1.5 mm <sup>2</sup>
Conductor cross section AWG/kcmil	24 ... 12	24 ... 16
Stripping length	7 mm	8 mm
Screw thread	M3	

**Ambient conditions**

Ambient temperature (operation)	-40 °C ... 55 °C (observe derating)
Ambient temperature (storage/transport)	-40 °C ... 85 °C
Max. permissible relative humidity (operation)	75 % (on average, 85% infrequently, non-condensing)
Max. permissible humidity (storage/transport)	75 % (on average, 85% infrequently, non-condensing)
Maximum altitude	max. 2000 m (Above sea level)
Shock	15g
Vibration (operation)	10 Hz ... 150 Hz, 2g

**Conformance / approvals**

Conformance	CE-compliant
Approvals	

**Safety data**

Stop category according to IEC 60204	0
--------------------------------------	---

**Safety parameters for IEC 61508 - High demand**

SIL	3
PFH <sub>d</sub>	$1.5 \times 10^{-9}$ (4 A DC13; 5 A AC15; 8760 switching cycles/year)
Demand rate	< 12 Months
Proof test interval	240 Months
Duration of use	240 Months

**Safety parameters for IEC 61508 - Low demand**

SIL	3
PFD <sub>avg</sub>	$1.47 \times 10^{-4}$
Proof test interval	60 Months
Duration of use	240 Months

**Safety parameters for EN 62061**

SIL CL	3
--------	---

**Safety characteristic data according to EN ISO 13849**

Category	4
Performance level	e (4 A DC13; 5 A AC15; 8760 switching cycles/year)
Duration of use	240 Months

For applications in PL e, the required demand rate for the safety function is once per month.

## 5 Safety notes



### **WARNING: Risk of electric shock**

During operation, parts of electrical switching devices carry hazardous voltages.

Before working on the switching device, disconnect the power.

Please observe the safety regulations of electrical engineering and industrial safety and liability associations!

Disregarding these safety regulations may result in death, serious personal injury or damage to equipment.

Startup, mounting, modifications, and upgrades should only be carried out by a skilled electrical engineer!



### **WARNING: Risk of automatic machine restart!**

For emergency stop applications, the machine must be prevented from restarting automatically by a higher-level control system.

Protective covers must not be removed when operating electrical switching devices.



### **WARNING: Danger due to faulty devices!**

The devices may be damaged following an error and correct operation can no longer be ensured.

In the event of an error, replace the device immediately.

Repairs to the device, especially if the housing must be opened, may only be carried out by the manufacturer or authorized persons. Otherwise the warranty is invalidated.



### **WARNING: Risk of automatic machine restart!**

When using the manual reset function with monitored start, the "cross-circuit between A2 (0 V) and the cable from the reset button to S34" error must be prevented by design-related measures, especially for safety functions with increased risk potential (see EN ISO 13849-2).



### **WARNING: Risk due to incorrect installation**

For reliable operation, the safety relay must be installed in housing protected from dust and humidity (IP54).

Carry out wiring according to the application. Refer to the "Application examples" section for this.



### **WARNING: Risk due to welded relay contacts**

A suitable and effective protective circuit is to be provided for inductive loads. This is to be implemented parallel to the load and not parallel to the switch contact.



### **WARNING: danger due to magnetic interference!**

Do not use the device in the vicinity of strong magnetic fields (e.g., caused by transformers or magnetic iron). The magnetic field strength of the environment must not exceed 30 A/m.



### **NOTE: Risk of damage to equipment due to noise emissions**

When operating relay modules the operator must meet the requirements for noise emission for electrical and electronic equipment (EN 61000-6-4) on the contact side and, if required, take appropriate measures.



### **NOTE: Risk of damage to equipment due to noise emissions**

This is a Class A product. In a domestic environment it may cause radion interference, in which case the user may be required to take adequate measures.



Only use power supply units with safe isolation and SELV / PELV in accordance with EN 50178/VDE 0160 (SELV / PELV).

## 6 Basic circuit diagram

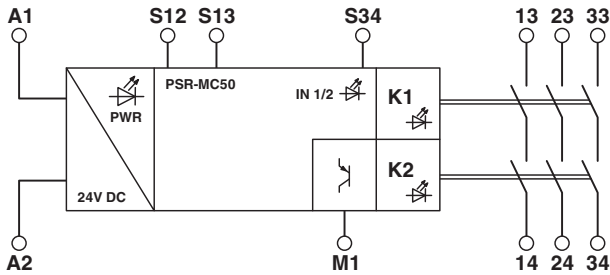

Figure 1 Block diagram

Key:

Designation	Explanation
A1	+24 V power supply
A2	0 V power supply
M1	Signal output (PNP)
S12	Input sensor circuit (channel 1)
S13	Input sensor circuit (channel 2)
S34	Start circuit
13/14	Undelayed enabling current paths
23/24	
33/34	

## 8 Load curve

### 8.1 Ohmic load

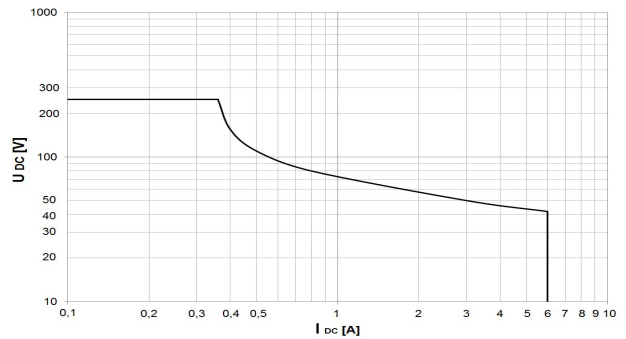

Figure 3 Relay load curve - ohmic load

## 7 Derating

### 7.1 Vertical or horizontal mounting position

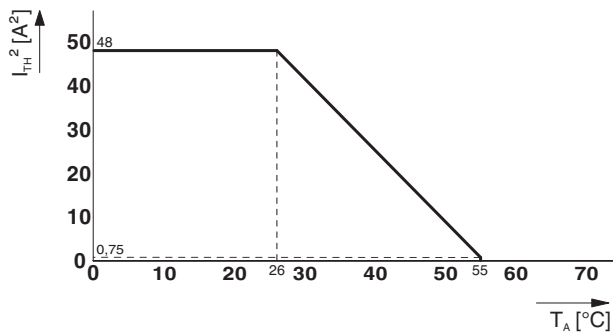

Figure 2 Derating curve - vertical or horizontal mounting position with connected modules

## 9 Function/time diagrams

Key:

Designation	Explanation
A1/A2	Power supply
S34	Start circuit
S12	Input sensor circuit (channel 1)
S13	Input sensor circuit (channel 2)
13/14, 23/24, 33/34	Undelayed enabling current paths
M1	Signal output (PNP)

### 9.1 Time diagram for automatic start

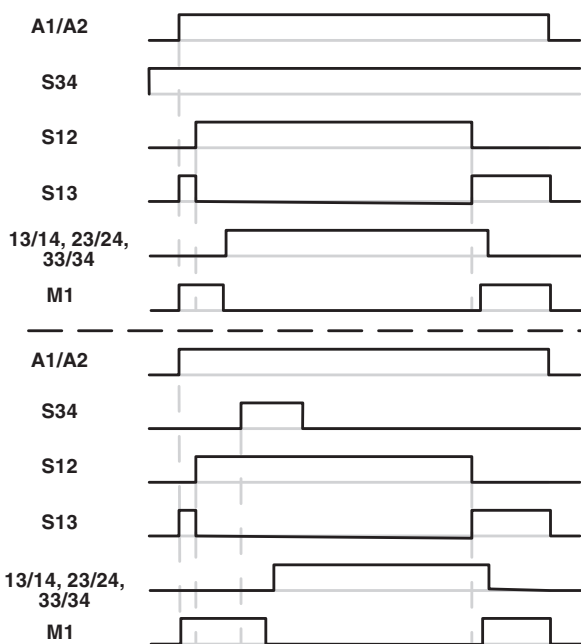

Figure 4 Time diagram for automatic start

### 9.2 Time diagram for manual, monitored start

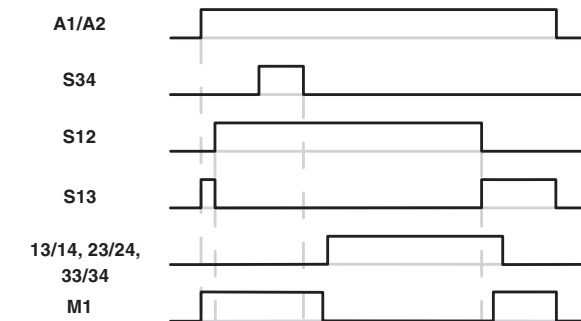

Figure 5 Time diagram for manual, monitored start

## 10 Operating and indication elements

### 10.1 Connection versions

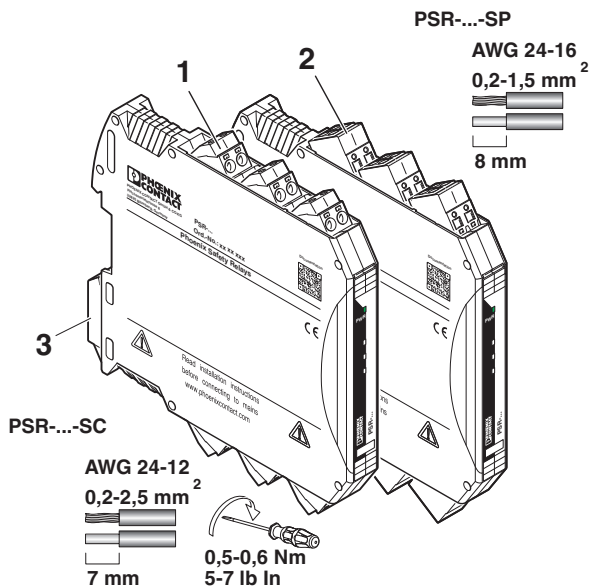

Figure 6 Connection versions

- 1 COMBICON plug-in screw terminal block
- 2 COMBICON plug-in spring-cage terminal block
- 3 Metal lock for fixing to DIN rail



The year the device was constructed can be found underneath the CE designation on the housing.

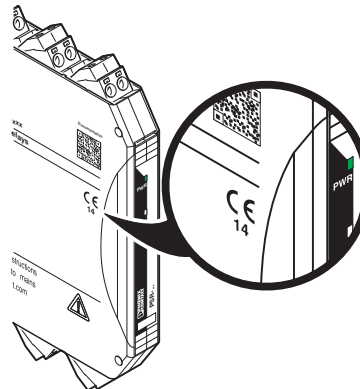

Figure 7 Year of manufacture of the device

### 10.2 Connection assignment

Figure	Designation	Explanation
	A1	+24 V power supply
	A2	0 V power supply
	M1	Signal output (PNP)
	S34	Start circuit
	S12	Input sensor circuit (channel 1)
	S13	Input sensor circuit (channel 2)
	PWR	Power LED (green)
	IN1/2	Status indicator sensor circuit; LED (green)
	K1	Status indicator safety circuit; LED (green)
	K2	Status indicator safety circuit; LED (green)
	13/14	Undelayed enabling current paths
	23/24	
	33/34	

## 11 Mounting and connection

Mount the module on a 35 mm DIN rail according to EN 60715.

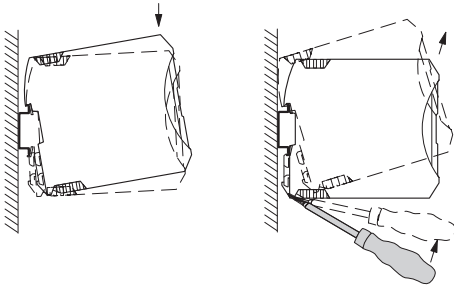

Figure 8 Mounting and removing

Connect the cables to the connection terminal blocks using a screwdriver.

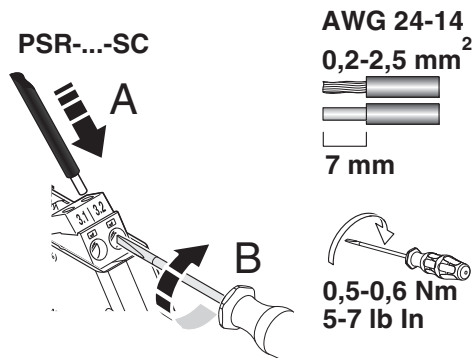

Figure 9 Connecting the cables for PSR-...-SC (screw terminal block)

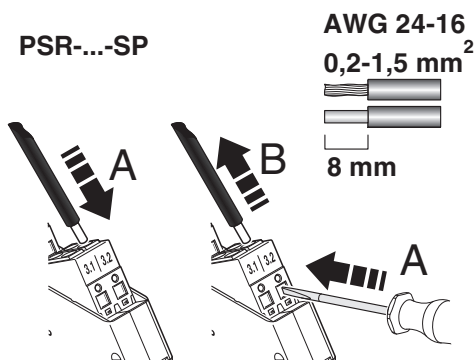

Figure 10 Connecting the cables for PSR-...-SC (spring-cage terminal block)



For compliance with UL approval, use copper wire that is approved up to 60°C/75°C.

## 12 Startup

Apply the rated control supply voltage (24 V DC) at terminal blocks A1/A2. The PWR LED lights up.

Close sensor circuit channel 1 (24 V/S12) and open channel 2 (24 V/S13). The IN1/2 LED lights up.

### Automatic or manual, monitored start:

Close contacts A1/S34 as follows.

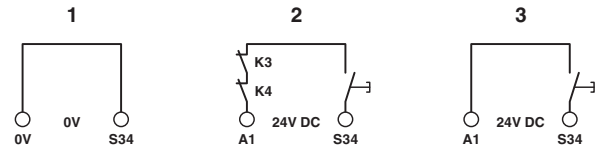

Figure 11 Connection of automatic or manual, monitored start

- 1 Automatic start
- 2 Manual, monitored start with monitored contact extension
- 3 Manual, monitored start

When automatic start is selected, the enabling current paths close.

For manual, monitored start, first press the reset button. The release of the button causes the enabling current paths to close.

The K1 and K2 LEDs light up.

If the supply voltage drops or the safety equipment is opened, the enabling current paths of the output circuits (13/14, 23/24, 33/34) open and the contacts enter the safe state.

### 13 Calculating the power dissipation



The total power dissipation of the safety relay is based on the input power dissipation and the contact power dissipation for the same and for different load currents.

#### Input power dissipation

$$P_{\text{Input}} = U_B^2 / (U_S / I_S)$$

#### Contact power dissipation

With the same load currents:

$$P_{\text{Contact}} = n \cdot I_L^2 \cdot 50 \text{ m}\Omega$$

With different load currents:

$$P_{\text{Contact}} = (I_{L1}^2 + I_{L2}^2 + \dots + I_{Ln}^2) \cdot 50 \text{ m}\Omega$$

#### Total power dissipation

$$P_{\text{Total}} = P_{\text{Input}} + P_{\text{Contact}}$$

therefore

$$P_{\text{Total}} = U_B^2 / (U_S / I_S) + n \cdot I_L^2 \cdot 50 \text{ m}\Omega$$

or

$$P_{\text{Total}} = U_B^2 / (U_S / I_S) + (I_{L1}^2 + I_{L2}^2 + \dots + I_{Ln}^2) \cdot 50 \text{ m}\Omega$$

#### Key:

Designation	Explanation
P	Power dissipation in mW
$U_B$	Applied operating voltage
$U_S$	Rated control supply voltage
$I_S$	Rated control supply current
n	Number of enabling current paths used
$I_L$	Contact load current

## 14 Diagnostics

### Function test/proof test

The following section describes the LED indicators for general states and error messages as well as possible causes and remedies.



Use the function test to check the safety function. To do this, request the safety function once by pressing the emergency stop button, for example. Check whether the safety function is running correctly by switching the device on again via the sensor circuits.

#### 14.1 General states

PWR LED	IN1/2 LED	K1 LED	K2 LED	State	Notes
ON	OFF	OFF	OFF	All relays are not activated. The sensor circuit is off.	Possible error see error messages
ON	ON	OFF	OFF	The sensor circuit is active. Relays K1 and K2 are ready to start and await reset/start command (S34).	-
ON	ON	ON	ON	The sensor circuit is active. All relays are picked up.	-

#### 14.2 Error Messages

PWR LED	IN1/2 LED	K1 LED	K2 LED	State	Possible cause	Remedy
ON	OFF	OFF	OFF	The sensor circuit is actively controlled, but no input LEDs are lit up.	Internal cross-circuit detection (via non-equivalence) is active: potential cross-circuit in the sensor circuit.	Switch off the operating voltage and rectify the cross-circuit. Then perform a function test.
ON	ON	OFF	OFF	The sensor circuit is active. The reset/start circuit (S34) is/was activated. The safety circuit (K1 and K2) is not picking up.	External error: the read-back contact (external actuator) is open in the reset circuit. Internal error: 1. The diagnostic contact is not working correctly. 2. An N/O contact is welded.	External error: check the actuator. Internal error: perform a power down reset with subsequent function test. <b>If the error occurs again after the function test, replace the device.</b>
ON	ON	OFF	OFF	The sensor circuit is active. The reset/start circuit (S34) is/was activated. The safety circuit (K1 and K2) is not picking up.	Error during manual reset S34 (stuck-at at the input).	Remove the error in the reset/start circuit. Then perform a function test.

PWR LED	IN1/2 LED	K1 LED	K2 LED	State	Possible cause	Remedy
ON	ON	OFF	ON	The sensor circuit is active. The reset/start circuit (S34) is/was activated. The safety circuit (K1) is not picking up.	External error: sensor circuit channel 1 was opened and reactivated. Internal error: diagnostics active.	External error: check the sensor circuit. Internal error: perform a power down reset with subsequent function test. <b>If the error occurs again after the function test, replace the device.</b>
ON	ON	ON	OFF	The sensor circuit is active. The reset/start circuit (S34) is/was activated. The safety circuit (K2) is not picking up.	External error: sensor circuit channel 2 was closed and reactivated. Internal error: diagnostics active.	External error: check the sensor circuit. Internal error: perform a power down reset with subsequent function test. <b>If the error occurs again after the function test, replace the device.</b>
OFF	OFF	OFF	OFF	The sensor circuit is active.	1. No supply voltage at A1/A 2. Over- or undervoltage at A1	Check the supply voltage.

## 15 Application examples

### Key:

- S1 = Mechanical safety door switch
- S2 = Manual reset device
- S3 = Solenoid switch
- K1/K2 = Contactors



Cross-circuits in the cable installation can be excluded if the safety relay and external contactors K1 and K2 are located in the same electrical installation space.

### Applications with the PSR-MC50

#### 15.1 Magnetic switch monitoring/automatic start

- Two-channel, non-equivalent magnetic switch monitoring
- Automatic start
- Suitable up to category 4, PL e (EN ISO 13849-1), SILCL 3 (EN 62061), if cross-circuits in the control to the actuator can be ruled out

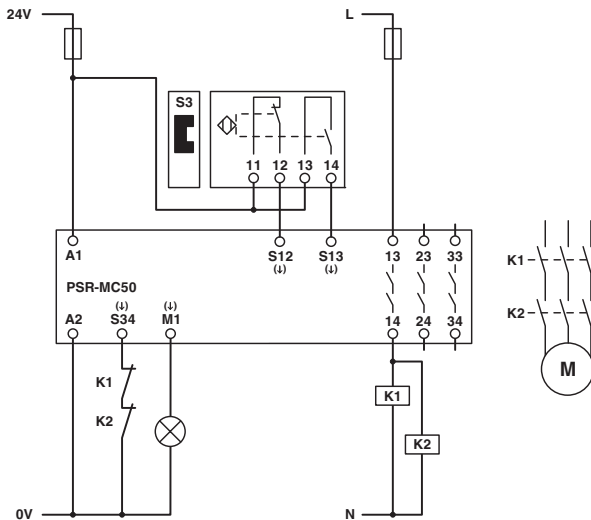

Figure 12 Magnetic switch monitoring/automatic start

#### 15.2 Magnetic switch monitoring/manual, monitored start

- Two-channel, non-equivalent magnetic switch monitoring
- Manual, monitored start
- Suitable up to category 4, PL e (EN ISO 13849-1), SILCL 3 (EN 62061), if cross-circuits in the control to the actuator can be ruled out

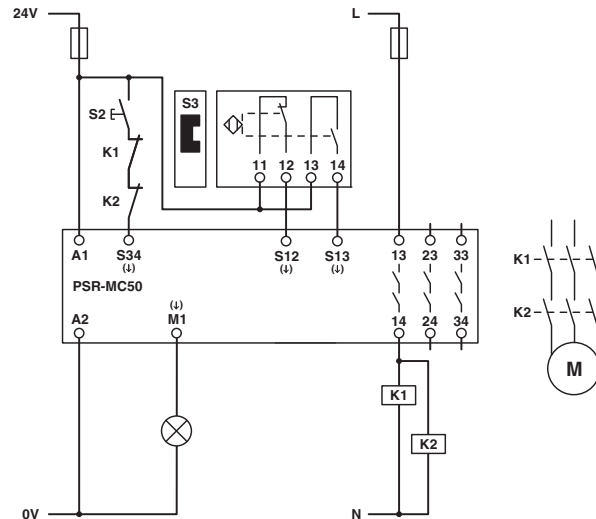

Figure 13 Magnetic switch monitoring/manual, monitored start

### 15.3 Safety door monitoring/automatic start

- Non-equivalent safety door monitoring
- Automatic start
- Suitable up to category 1, PL c (EN ISO 13849-1), SILCL 1 (EN 62061)
- Suitable up to category 4, PL e (EN ISO 13849-1), SILCL 3 (EN 62061), if cross-circuits in the control can be excluded from the actuator and when using the two switches in design 1

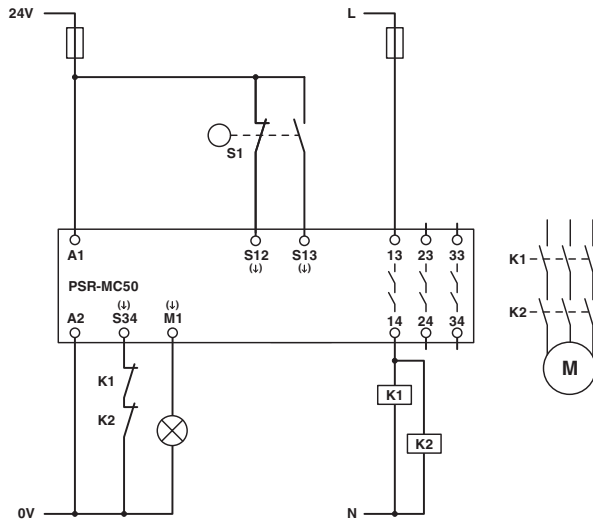

Figure 14 Safety door monitoring/automatic start

### 15.4 Safety door monitoring/manual, monitored start

- Non-equivalent safety door monitoring
- Manual, monitored start
- Suitable up to category 1, PL c (EN ISO 13849-1), SILCL 1 (EN 62061)
- Suitable up to category 4, PL e (EN ISO 13849-1), SILCL 3 (EN 62061), if cross-circuits in the control can be excluded from the actuator and when using the two switches in design 1

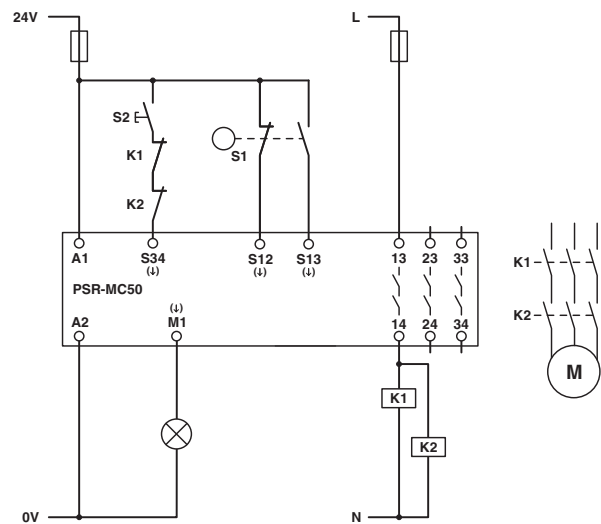

Figure 15 Safety door monitoring/manual, monitored start

## 16 Revision history

Version	Date	Contents
00	2014-12-03	First publication
01	2015-03-05	Reverse polarity protection extended; relay type extended; dimensions updated; load curve extended
01_c00	2015-05-19	Caption of figure 3 corrected (translation error)