

# SPECIFICATION

SPEC. No. C-MEGA-d

D A T E : 2017 Aug.

To

**Non-Controlled Copy**

CUSTOMER'S PRODUCT NAME

TDK PRODUCT NAME

Multilayer Ceramic Chip Capacitors  
CKG Series/ Commercial grade  
MEGACAP type

Please return this specification to TDK representatives with your signature.  
If orders are placed without returned specification, please allow us to judge that specification is accepted by your side.

## RECEIPT CONFIRMATION

DATE: \_\_\_\_\_ YEAR \_\_\_\_\_ MONTH \_\_\_\_\_ DAY \_\_\_\_\_

TDK Corporation  
Sales  
Electronic Components  
Sales & Marketing Group

Engineering  
Electronic Components Business Company  
Ceramic Capacitors Business Group

APPROVED	Person in charge

APPROVED	CHECKED	Person in charge

## 1. SCOPE

This specification is applicable to chip type multilayer ceramic capacitors with a priority over the other relevant specifications.

Production places defined in this specification shall be TDK Corporation Japan, TDK(Suzhou)Co.,Ltd, TDK Xiamen Co.,Ltd, and TDK Components U.S.A.Inc.

### EXPLANATORY NOTE:

This specification warrants the quality of the ceramic chip capacitors. Capacitors should be evaluated or confirmed a state of mounted on your product.

If the use of capacitors goes beyond the bounds of the specification, we can not afford to guarantee.

## 2. CODE CONSTRUCTION

Catalog Number (Web)	<u>CKG32K</u>	<u>X7S</u>	<u>1H</u>	<u>106</u>	<u>K</u>	<u>335</u>	<u>A</u>	<u>H</u>
	<u>CKG57N</u>	<u>X7R</u>	<u>1E</u>	<u>226</u>	<u>M</u>	<u>500</u>	<u>J</u>	<u>H</u>
	(1)	(2)	(3)	(4)	(5)	(6)	(7)	(8)
Item Description	<u>CKG32K</u>	<u>X7S</u>	<u>1H</u>	<u>106</u>	<u>K</u>	<u>T</u>	<u>xxxx</u>	
	<u>CKG57N</u>	<u>X7R</u>	<u>1E</u>	<u>226</u>	<u>M</u>	<u>T</u>	<u>xxxx</u>	
	(1)	(2)	(3)	(4)	(5)	(9)	(10)	

### (1) Type

Single type  
CKG\*\*K: 1 chip capacitor.

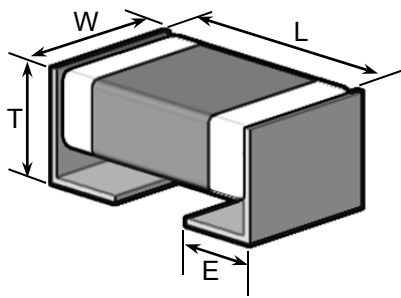

Stacked type  
CKG\*\*N: 2 chip capacitors.

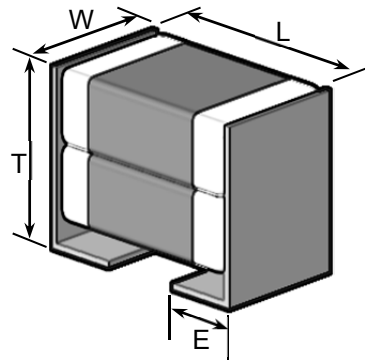

\* As for dimensions, please refer to detail page of each products on TDK Web.

### (2) Temperature Characteristics

\* Details are shown in table 1 No.6 and 7 at 6.PERFORMANCE

### (3) Rated Voltage

Symbol	Rated Voltage
3 A	DC 1k V
2 J	DC 630 V
2 W	DC 450 V
2 E	DC 250 V
2 A	DC 100 V
1 H	DC 50 V
1 V	DC 35 V
1 E	DC 25 V
1 C	DC 16 V

(4) Rated Capacitance

Stated in three digits and in units of pico farads (pF). The first and Second digits identify the first and second significant figures of the capacitance, the third digit identifies the multiplier.

(Example)

Symbol	Rated Capacitance
106	10,000,000 pF
226	22,000,000 pF

(5) Capacitance tolerance

\* K (±10%) tolerance is available only for CKG\*\*K single type (10µF and under).

Symbol	Tolerance
J	± 5 %
*K	± 10 %
M	± 20 %

(6) Thickness Code (Only for Catalog Number)

(7) Package Code (Only for Catalog Number)

(8) Special Code (Only for Catalog Number)

(9) Packaging Code (Only for Item Description)

Symbol	Packaging
T	Taping

(10) Internal Code (Only for Item Description)

3. OPERATING TEMPERATURE RANGE

T.C.	Min. operating Temperature	Max. operating Temperature	Reference Temperature
X5R	-55°C	85°C	25°C
C0G, X7R, X7S, X7T	-55°C	125°C	25°C

4. STORING CONDITION AND TERM

5 to 40°C at 20 to 70%RH  
6 months Max.

5. INDUSTRIAL WASTE DISPOSAL

Dispose this product as industrial waste in accordance with the Industrial Waste Law.

6. PERFORMANCE

table 1

No.	Item	Performance	Test or inspection method																					
1	External Appearance	No defects which may affect performance.	Inspect with magnifying glass (3×)																					
2	Insulation Resistance	10,000MΩ or 500MΩ·μF min. (As for the capacitors of rated voltage 16V DC, 100MΩ·μF min.)	Apply rated voltage for 60s. As for the rated voltage 630V DC and higher, apply 500V DC.																					
3	Voltage Proof	Withstand test voltage without insulation breakdown or other damage.	<table border="1"> <thead> <tr> <th>Class</th> <th>Rated voltage(RV)</th> <th>Apply voltage</th> </tr> </thead> <tbody> <tr> <td rowspan="4">1</td> <td><math>RV \leq 100V</math></td> <td>3 × rated voltage</td> </tr> <tr> <td><math>100V &lt; RV \leq 500V</math></td> <td>1.5 × rated voltage</td> </tr> <tr> <td><math>500V &lt; RV &lt; 1kV</math></td> <td>1.3 × rated voltage</td> </tr> <tr> <td>1kV</td> <td>1.2 × rated voltage</td> </tr> <tr> <td rowspan="4">2</td> <td><math>RV \leq 100V</math></td> <td>2.5 × rated voltage</td> </tr> <tr> <td><math>100V &lt; RV \leq 500V</math></td> <td>1.5 × rated voltage</td> </tr> <tr> <td><math>500V &lt; RV &lt; 1kV</math></td> <td>1.3 × rated voltage</td> </tr> <tr> <td>1kV</td> <td>1.2 × rated voltage</td> </tr> </tbody> </table> <p>Above DC voltage shall be applied for 1s. Charge / discharge current shall not exceed 50mA.</p>	Class	Rated voltage(RV)	Apply voltage	1	$RV \leq 100V$	3 × rated voltage	$100V < RV \leq 500V$	1.5 × rated voltage	$500V < RV < 1kV$	1.3 × rated voltage	1kV	1.2 × rated voltage	2	$RV \leq 100V$	2.5 × rated voltage	$100V < RV \leq 500V$	1.5 × rated voltage	$500V < RV < 1kV$	1.3 × rated voltage	1kV	1.2 × rated voltage
Class	Rated voltage(RV)	Apply voltage																						
1	$RV \leq 100V$	3 × rated voltage																						
	$100V < RV \leq 500V$	1.5 × rated voltage																						
	$500V < RV < 1kV$	1.3 × rated voltage																						
	1kV	1.2 × rated voltage																						
2	$RV \leq 100V$	2.5 × rated voltage																						
	$100V < RV \leq 500V$	1.5 × rated voltage																						
	$500V < RV < 1kV$	1.3 × rated voltage																						
	1kV	1.2 × rated voltage																						
4	Capacitance	Within the specified tolerance.	<table border="1"> <thead> <tr> <th>Class</th> <th>Capacitance</th> <th>Measuring frequency</th> <th>Measuring voltage</th> </tr> </thead> <tbody> <tr> <td rowspan="2">1</td> <td>1000pF</td> <td>1MHz±10%</td> <td rowspan="2">0.5-5Vrms.</td> </tr> <tr> <td>Over 1000pF</td> <td>1kHz±10%</td> </tr> <tr> <td rowspan="2">2</td> <td>10uF and under</td> <td>1kHz±10%</td> <td>1.0±0.2Vrms</td> </tr> <tr> <td>Over 10uF</td> <td>120Hz±20%</td> <td>0.5±0.2Vrms.</td> </tr> </tbody> </table>	Class	Capacitance	Measuring frequency	Measuring voltage	1	1000pF	1MHz±10%	0.5-5Vrms.	Over 1000pF	1kHz±10%	2	10uF and under	1kHz±10%	1.0±0.2Vrms	Over 10uF	120Hz±20%	0.5±0.2Vrms.				
Class	Capacitance	Measuring frequency	Measuring voltage																					
1	1000pF	1MHz±10%	0.5-5Vrms.																					
	Over 1000pF	1kHz±10%																						
2	10uF and under	1kHz±10%	1.0±0.2Vrms																					
	Over 10uF	120Hz±20%	0.5±0.2Vrms.																					
5	Q (Class1)	1,000 Min.	See No.4 in this table for measuring condition.																					
	Dissipation Factor (Class2)	Please refer to detail page of each products on TDK Web.																						
6	Temperature Characteristics of Capacitance (Class1)	<table border="1"> <thead> <tr> <th>T.C.</th> <th>Temperature Coefficient (ppm/°C)</th> </tr> </thead> <tbody> <tr> <td>C0G</td> <td>0 ± 30</td> </tr> </tbody> </table> <p>Capacitance drift within ± 0.2% or ± 0.05pF, whichever larger.</p>	T.C.	Temperature Coefficient (ppm/°C)	C0G	0 ± 30	<p>Temperature coefficient shall be calculated based on values at 25°C and 85°C temperature.</p> <p>Measuring temperature below 25°C shall be -10°C and -25°C.</p>																	
T.C.	Temperature Coefficient (ppm/°C)																							
C0G	0 ± 30																							

(continued)

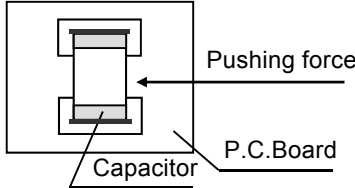
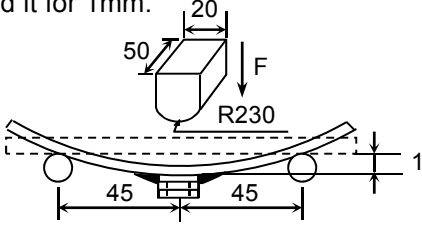
No.	Item	Performance	Test or inspection method										
7	Temperature Characteristics of Capacitance	<p style="text-align: center;">Capacitance Change (%)</p> <hr/> <p style="text-align: center;">No voltage applied</p> <hr/> <p style="text-align: center;">X5R : ± 15</p> <p style="text-align: center;">X7R : ±15</p> <p style="text-align: center;">X7S : ±22</p> <p style="text-align: center;">X7T : +22 -33</p> <hr/>	<p>Capacitance shall be measured by the steps shown in the following table after thermal equilibrium is obtained for each step.  <math>\Delta C</math> be calculated ref. STEP3 reading</p> <table border="1" data-bbox="986 383 1430 651"> <thead> <tr> <th>Step</th> <th>Temperature(°C)</th> </tr> </thead> <tbody> <tr> <td>1</td> <td>Reference temp. ± 2</td> </tr> <tr> <td>2</td> <td>Min. operating temp. ± 2</td> </tr> <tr> <td>3</td> <td>Reference temp. ± 2</td> </tr> <tr> <td>4</td> <td>Max. operating temp. ± 2</td> </tr> </tbody> </table> <p>Measuring voltage: 0.1, 0.2, 0.5, 1.0Vrms.            For information which product has which applied voltage, please contact with our sales representative.</p>	Step	Temperature(°C)	1	Reference temp. ± 2	2	Min. operating temp. ± 2	3	Reference temp. ± 2	4	Max. operating temp. ± 2
Step	Temperature(°C)												
1	Reference temp. ± 2												
2	Min. operating temp. ± 2												
3	Reference temp. ± 2												
4	Max. operating temp. ± 2												
8	Robustness of Terminations	No sign of termination coming off, breakage of ceramic, or other abnormal signs.	<p>Reflow solder the capacitors on a P.C.Board shown in Appendix 2 and apply a pushing force of 5N with 10±1s.</p>  <p>The diagram shows a cross-section of a capacitor mounted on a P.C. Board. A horizontal arrow labeled 'Pushing force' points to the left, indicating the direction of the applied force. The capacitor is labeled 'Capacitor' and the board is labeled 'P.C. Board'.</p>										
9	Bending	No mechanical damage.	<p>Reflow solder the capacitors on a P.C.Board shown in Appendix 1 and bend it for 1mm.</p>  <p>The diagram shows a top-down view of a capacitor on a P.C. Board being bent. The board is supported by two circular points, each 45 mm from the center of the capacitor. A downward force 'F' is applied to the center of the board, which has a width of 20 mm. The board is bent with a radius of R230. The final bend height is 1 mm. Dimensions are in mm.</p> <p style="text-align: right;">(Unit : mm)</p>										

(continued)

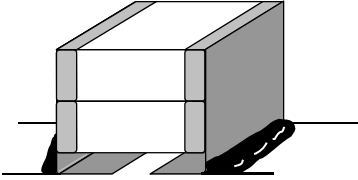
No.	Item	Performance	Test or inspection method																																										
10	Solderability	<p>Both end faces and the contact areas shall be covered with a smooth and bright solder coating with no more than a small amount of scattered imperfections such as pinholes or un-wetted or de-wetted areas. These imperfections shall not be concentrated in one area.</p> 	<p>Reflow solder the capacitor on a P.C.Board shown in Appendix2.</p> <p>Solder : Sn-3.0Ag-0.5Cu or Sn-37Pb</p> <p>Please refer to the condition at page15,16 for soldering.</p>																																										
11	Vibration	<table border="1"> <tr> <td data-bbox="359 743 518 817">External appearance</td> <td colspan="2" data-bbox="518 743 957 817">No mechanical damage.</td> </tr> <tr> <td data-bbox="359 817 518 1120" rowspan="2">Capacitance</td> <td colspan="2" data-bbox="518 817 957 896"> <table border="1"> <tr> <th colspan="2" data-bbox="542 840 710 884">Characteristics</th> <th data-bbox="710 840 949 896">Change from the value before test</th> </tr> <tr> <td data-bbox="542 907 630 974">Class1</td> <td data-bbox="630 907 710 974">C0G</td> <td data-bbox="710 907 949 974">± 2.5 %</td> </tr> <tr> <td data-bbox="542 974 630 1108">Class2</td> <td data-bbox="630 974 710 1108">X5R X7R X7S X7T</td> <td data-bbox="710 974 949 1108">± 7.5 %</td> </tr> </table> </td> </tr> <tr> <td data-bbox="359 1120 518 1198">Q (Class1)</td> <td colspan="2" data-bbox="518 1120 957 1198">Meet the initial spec.</td> </tr> <tr> <td data-bbox="359 1198 518 1276">D.F. (Class2)</td> <td colspan="2" data-bbox="518 1198 957 1276">Meet the initial spec.</td> </tr> </table>	External appearance	No mechanical damage.		Capacitance	<table border="1"> <tr> <th colspan="2" data-bbox="542 840 710 884">Characteristics</th> <th data-bbox="710 840 949 896">Change from the value before test</th> </tr> <tr> <td data-bbox="542 907 630 974">Class1</td> <td data-bbox="630 907 710 974">C0G</td> <td data-bbox="710 907 949 974">± 2.5 %</td> </tr> <tr> <td data-bbox="542 974 630 1108">Class2</td> <td data-bbox="630 974 710 1108">X5R X7R X7S X7T</td> <td data-bbox="710 974 949 1108">± 7.5 %</td> </tr> </table>		Characteristics		Change from the value before test	Class1	C0G	± 2.5 %	Class2	X5R X7R X7S X7T	± 7.5 %	Q (Class1)	Meet the initial spec.		D.F. (Class2)	Meet the initial spec.		<p>Reflow solder the capacitors on a P.C.Board shown in Appendix 2 before testing.</p> <p>Vibrate the capacitors with amplitude of 1.5mm P-P changing the frequencies from 10Hz to 55Hz and back to 10Hz in about 1min.</p> <p>Repeat this for 2h each in 3 perpendicular directions.</p>																					
External appearance	No mechanical damage.																																												
Capacitance	<table border="1"> <tr> <th colspan="2" data-bbox="542 840 710 884">Characteristics</th> <th data-bbox="710 840 949 896">Change from the value before test</th> </tr> <tr> <td data-bbox="542 907 630 974">Class1</td> <td data-bbox="630 907 710 974">C0G</td> <td data-bbox="710 907 949 974">± 2.5 %</td> </tr> <tr> <td data-bbox="542 974 630 1108">Class2</td> <td data-bbox="630 974 710 1108">X5R X7R X7S X7T</td> <td data-bbox="710 974 949 1108">± 7.5 %</td> </tr> </table>		Characteristics		Change from the value before test	Class1	C0G	± 2.5 %	Class2	X5R X7R X7S X7T	± 7.5 %																																		
	Characteristics		Change from the value before test																																										
Class1	C0G	± 2.5 %																																											
Class2	X5R X7R X7S X7T	± 7.5 %																																											
Q (Class1)	Meet the initial spec.																																												
D.F. (Class2)	Meet the initial spec.																																												
12	Temperature cycle	<table border="1"> <tr> <td data-bbox="359 1288 518 1361">External appearance</td> <td colspan="2" data-bbox="518 1288 957 1361">No mechanical damage.</td> </tr> <tr> <td data-bbox="359 1361 518 1691" rowspan="2">Capacitance</td> <td colspan="2" data-bbox="518 1361 957 1444"> <table border="1"> <tr> <th colspan="2" data-bbox="542 1384 710 1429">Characteristics</th> <th data-bbox="710 1384 949 1444">Change from the value before test</th> </tr> <tr> <td data-bbox="542 1444 630 1512">Class1</td> <td data-bbox="630 1444 710 1512">C0G</td> <td data-bbox="710 1444 949 1512">± 2.5 %</td> </tr> <tr> <td data-bbox="542 1512 630 1668">Class2</td> <td data-bbox="630 1512 710 1668">X5R X7R X7S X7T</td> <td data-bbox="710 1512 949 1668">± 7.5 %</td> </tr> </table> </td> </tr> <tr> <td data-bbox="359 1691 518 1769">Q (Class1)</td> <td colspan="2" data-bbox="518 1691 957 1769">Meet the initial spec.</td> </tr> <tr> <td data-bbox="359 1769 518 1848">D.F. (Class2)</td> <td colspan="2" data-bbox="518 1769 957 1848">Meet the initial spec.</td> </tr> <tr> <td data-bbox="359 1848 518 1926">Insulation Resistance</td> <td colspan="2" data-bbox="518 1848 957 1926">Meet the initial spec.</td> </tr> <tr> <td data-bbox="359 1926 518 2069">Voltage proof</td> <td colspan="2" data-bbox="518 1926 957 2069">No insulation breakdown or other damage.</td> </tr> </table>	External appearance	No mechanical damage.		Capacitance	<table border="1"> <tr> <th colspan="2" data-bbox="542 1384 710 1429">Characteristics</th> <th data-bbox="710 1384 949 1444">Change from the value before test</th> </tr> <tr> <td data-bbox="542 1444 630 1512">Class1</td> <td data-bbox="630 1444 710 1512">C0G</td> <td data-bbox="710 1444 949 1512">± 2.5 %</td> </tr> <tr> <td data-bbox="542 1512 630 1668">Class2</td> <td data-bbox="630 1512 710 1668">X5R X7R X7S X7T</td> <td data-bbox="710 1512 949 1668">± 7.5 %</td> </tr> </table>		Characteristics		Change from the value before test	Class1	C0G	± 2.5 %	Class2	X5R X7R X7S X7T	± 7.5 %	Q (Class1)	Meet the initial spec.		D.F. (Class2)	Meet the initial spec.		Insulation Resistance	Meet the initial spec.		Voltage proof	No insulation breakdown or other damage.		<p>Reflow solder the capacitors on a P.C.Board shown in Appendix 2 before testing.</p> <p>Expose the capacitors in the condition step1 through step 4 and repeat 100 times consecutively.</p> <p>Leave the capacitors in ambient condition for 6 to 24h (Class 1) or 24±2h (Class 2) before measurement.</p> <table border="1"> <thead> <tr> <th data-bbox="973 1635 1045 1691">Step</th> <th data-bbox="1045 1635 1308 1691">Temperature(°C)</th> <th data-bbox="1308 1635 1460 1691">Time (min.)</th> </tr> </thead> <tbody> <tr> <td data-bbox="973 1691 1045 1758">1</td> <td data-bbox="1045 1691 1308 1758">Min. operating temp. ±3</td> <td data-bbox="1308 1691 1460 1758">30 ± 3</td> </tr> <tr> <td data-bbox="973 1758 1045 1803">2</td> <td data-bbox="1045 1758 1308 1803">Ambient Temp.</td> <td data-bbox="1308 1758 1460 1803">2 - 5</td> </tr> <tr> <td data-bbox="973 1803 1045 1870">3</td> <td data-bbox="1045 1803 1308 1870">Max. operating temp. ±2</td> <td data-bbox="1308 1803 1460 1870">30 ± 2</td> </tr> <tr> <td data-bbox="973 1870 1045 1926">4</td> <td data-bbox="1045 1870 1308 1926">Ambient Temp.</td> <td data-bbox="1308 1870 1460 1926">2 - 5</td> </tr> </tbody> </table> <p>As for Min./ Max. operating temp., please refer to "3.OPERATING TEMPERATURE RANGE".</p>	Step	Temperature(°C)	Time (min.)	1	Min. operating temp. ±3	30 ± 3	2	Ambient Temp.	2 - 5	3	Max. operating temp. ±2	30 ± 2	4	Ambient Temp.	2 - 5
External appearance	No mechanical damage.																																												
Capacitance	<table border="1"> <tr> <th colspan="2" data-bbox="542 1384 710 1429">Characteristics</th> <th data-bbox="710 1384 949 1444">Change from the value before test</th> </tr> <tr> <td data-bbox="542 1444 630 1512">Class1</td> <td data-bbox="630 1444 710 1512">C0G</td> <td data-bbox="710 1444 949 1512">± 2.5 %</td> </tr> <tr> <td data-bbox="542 1512 630 1668">Class2</td> <td data-bbox="630 1512 710 1668">X5R X7R X7S X7T</td> <td data-bbox="710 1512 949 1668">± 7.5 %</td> </tr> </table>		Characteristics		Change from the value before test	Class1	C0G	± 2.5 %	Class2	X5R X7R X7S X7T	± 7.5 %																																		
	Characteristics		Change from the value before test																																										
Class1	C0G	± 2.5 %																																											
Class2	X5R X7R X7S X7T	± 7.5 %																																											
Q (Class1)	Meet the initial spec.																																												
D.F. (Class2)	Meet the initial spec.																																												
Insulation Resistance	Meet the initial spec.																																												
Voltage proof	No insulation breakdown or other damage.																																												
Step	Temperature(°C)	Time (min.)																																											
1	Min. operating temp. ±3	30 ± 3																																											
2	Ambient Temp.	2 - 5																																											
3	Max. operating temp. ±2	30 ± 2																																											
4	Ambient Temp.	2 - 5																																											

(continued)

No.	Item		Performance	Test or inspection method					
13	Moisture Resistance	External appearance	No mechanical damage.	<p>Reflow solder the capacitors on a P.C.Board shown in Appendix2 before testing.</p> <p>Apply the rated voltage at <math>40 \pm 2^{\circ}\text{C}</math> and 90 to 95%RH for 500 +24,0h.</p> <p>Charge/discharge current shall not exceed 50mA.</p> <p>Leave the capacitors in ambient condition for 6 to 24h (Class1) or <math>24 \pm 2\text{h}</math> (Class2) before measurement.</p> <p>Voltage conditioning (only for class 2) Voltage treat the capacitors under testing temperature and voltage for 1 hour.</p> <p>Leave the capacitors in ambient condition for <math>24 \pm 2\text{h}</math> before measurement.</p> <p>Use this measurement for initial value.</p>					
		Capacitance	Characteristics		Change from the value before test				
			Class 1		C0G	$\pm 7.5 \%$			
		Q (Class1)	D.F. (Class2)		Class 2	X5R X7R X7S X7T	$\pm 12.5 \%$		
					Insulation Resistance		500M $\Omega$ or 25M $\Omega$ · $\mu\text{F}$ min. (As for the capacitors of rated voltage 16V DC, 5M $\Omega$ · $\mu\text{F}$ min.,).		
14	Life	External appearance	No mechanical damage.	<p>Reflow solder the capacitors on a P.C.Board shown in Appendix2 before testing.</p> <p>Test condition : maximum operating temperature <math>\pm 2^{\circ}\text{C}</math> for 1,000 +48,0h</p> <table style="margin-left: auto; margin-right: auto; border-collapse: collapse;"> <tr><td style="border: 1px solid black; padding: 2px;">Applied Voltage</td></tr> <tr><td style="border: 1px solid black; padding: 2px;">Rated Voltage x 2</td></tr> <tr><td style="border: 1px solid black; padding: 2px;">Rated Voltage x 1.5</td></tr> <tr><td style="border: 1px solid black; padding: 2px;">Rated Voltage x 1.2</td></tr> <tr><td style="border: 1px solid black; padding: 2px;">Rated Voltage x 1</td></tr> </table> <p>As for applied voltage, please contact with our sales representative.</p> <p>Charge/discharge current shall not exceed 50mA.</p> <p>Leave the capacitors in ambient condition for 6 to 24h (Class1) or <math>24 \pm 2\text{h}</math> (Class2) before measurement.</p> <p>Voltage conditioning (only for class 2) Voltage treat the capacitors under testing temperature and voltage for 1 hour.</p> <p>Leave the capacitors in ambient condition for <math>24 \pm 2\text{h}</math> before measurement.</p> <p>Use this measurement for initial value.</p>	Applied Voltage	Rated Voltage x 2	Rated Voltage x 1.5	Rated Voltage x 1.2	Rated Voltage x 1
		Applied Voltage							
		Rated Voltage x 2							
		Rated Voltage x 1.5							
		Rated Voltage x 1.2							
Rated Voltage x 1									
Capacitance	Characteristics		Change from the value before test						
	Class1	C0G	$\pm 3 \%$						
Q (Class1)	D.F. (Class2)	Class2	X5R X7R X7S X7T	$\pm 15 \%$					
		Insulation Resistance		1,000M $\Omega$ or 50M $\Omega$ · $\mu\text{F}$ min. (As for the capacitors of rated voltage 16V DC, 10M $\Omega$ · $\mu\text{F}$ min.,)					

\*As for the initial measurement of capacitors (Class2) on number 7,11 and 12 leave capacitors at  $150 - 10,0^{\circ}\text{C}$  for 1 hour and measure the value after leaving capacitors for  $24 \pm 2\text{h}$  in ambient condition.

**Appendix1**  
**P.C.Board for bending test**

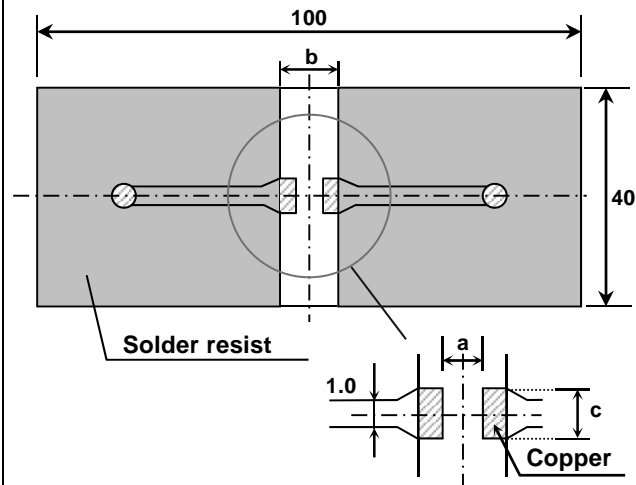

**Appendix2**  
**P.C. Board for reliability test**

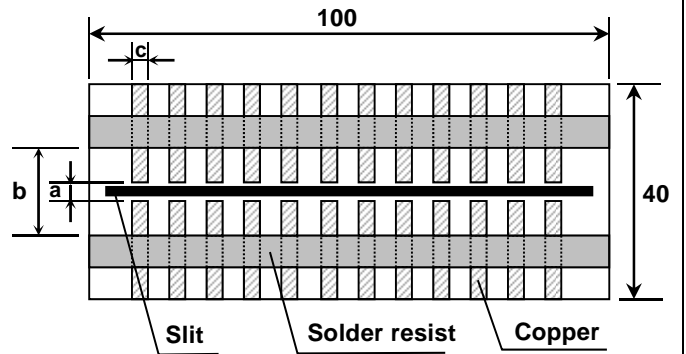

(Unit : mm)

Type	Dimensions		
	a	b	c
TDK(EIA style)			
CKG32K	2.2	5.0	2.9
CKG45K	3.5	6.1	2.9
CKG57K	4.1	7.6	4.7
CKG45N	3.5	6.1	2.9
CKG57N	4.1	7.6	4.7

1. Material : Glass Epoxy(As per JIS C6484 GE4)

2. Thickness : 1.6mm

 Copper (Thickness:0.035mm)

 Solder resist

# 7. INSIDE STRUCTURE AND MATERIAL

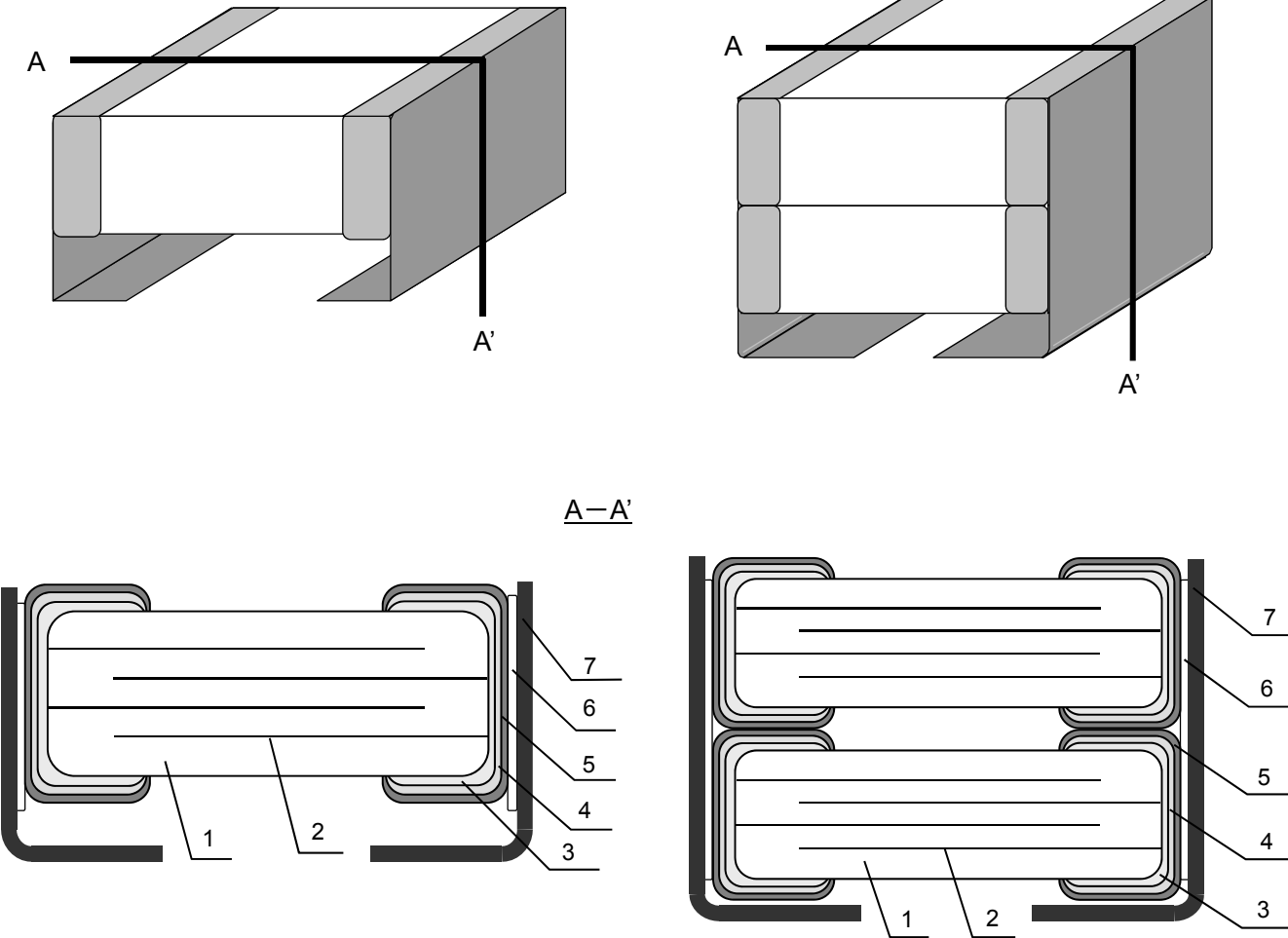

No.	NAME	MATERIAL	
		Class1	Class2
1	Dielectric	CaZrO <sub>3</sub>	BaTiO <sub>3</sub>
2	Electrode	Nickel (Ni)	
3	Termination	Copper (Cu)	
4		Nickel (Ni)	
5		Tin (Sn)	
6	Metal cap joint	High temp solder	
7	Metal frame	42 Alloy	

## 8. PACKAGING

Packaging shall be done to protect the components from the damage during transportation and storing, and a label which has the following information shall be attached.

Tape packaging is as per 12.TAPE PACKAGING SPECIFICATION.

Information on label

- 1) Inspection No.
- 2) TDK P/N
- 3) Customer's P/N
- 4) Quantity

\*Composition of Inspection No.

Example    A 7 A — 00 — 000  
                 (a) (b) (c)            (d)            (e)

- a) Line code
- b) Last digit of the year
- c) Month and A for January and B for February and so on.(Skip I)
- d) Inspection Date of the month.
- e) Serial No. of the day

## 9. RECOMMENDATION

It is recommended to provide a slit (about 1mm wide) in the board under the components to improve washing Flux.

And please make sure to dry detergent up completely before.

## 10. SOLDERING CONDITION

Reflow soldering only.

“Metal cap joint” is high temperature solder, but it may be melted under high temperature (more than 250°C).

Please keep a soldering temperature of 250°C or less and refer to 11.CAUTION on page 15-17 in detail.

# 11. CAUTION

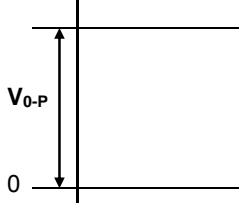
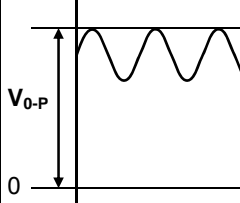
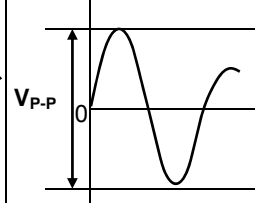
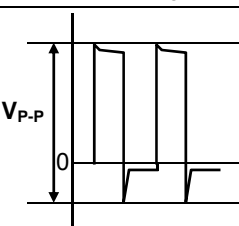
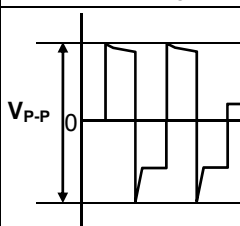
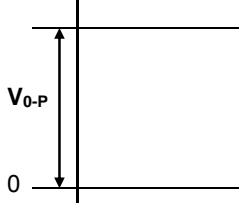
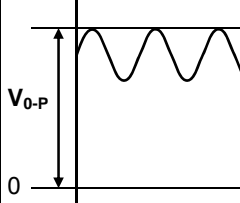
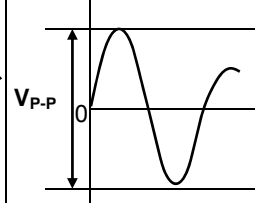
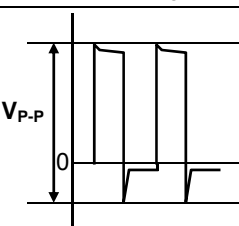
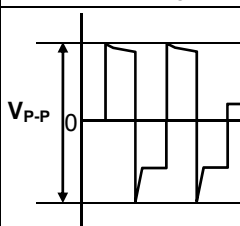
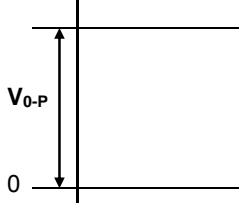
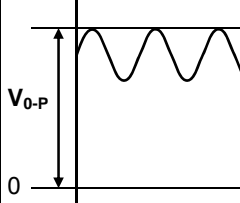
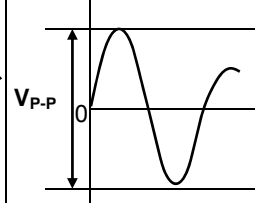
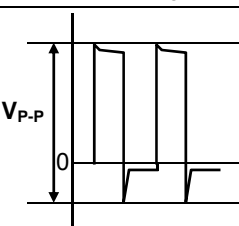
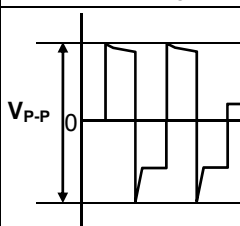
No.	Process	Condition																
1	Operating Condition (Storage, Transportation)	<p>1-1. Storage</p> <ol style="list-style-type: none"> <li>1) The capacitors must be stored in an ambient temperature of 5 to 40°C with a relative humidity of 20 to 70%RH. The products should be used within 6 months upon receipt.</li> <li>2) The capacitors must be operated and stored in an environment free of dew condensation and these gases such as Hydrogen Sulphide, Hydrogen Sulphate, Chlorine, Ammonia and sulfur.</li> <li>3) Avoid storing in sun light and falling of dew.</li> <li>4) Do not use capacitors under high humidity and high and low atmospheric pressure which may affect capacitors reliability.</li> <li>5) Capacitors should be tested for the solderability when they are stored for long time.</li> </ol> <p>1-2. Handling in transportation</p> <p>In case of the transportation of the capacitors, the performance of the capacitors may be deteriorated depending on the transportation condition.            (Refer to JEITA RCR-2335C 9.2 Handling in transportation)</p>																
2	Circuit design ⚠ Caution	<p>2-1. Operating temperature</p> <p>Operating temperature should be followed strictly within this specification, especially be careful with maximum temperature.</p> <ol style="list-style-type: none"> <li>1) Do not use capacitors above the maximum allowable operating temperature.</li> <li>2) Surface temperature including self heating should be below maximum operating temperature.            (Due to dielectric loss, capacitors will heat itself when AC is applied. Especially at high frequencies around its SRF, the heat might be so extreme that it may damage itself or the product mounted on. Please design the circuit so that the maximum temperature of the capacitors including the self heating to be below the maximum allowable operating temperature. Temperature rise at capacitor surface shall be below 20°C)</li> <li>3) The electrical characteristics of the capacitors will vary depending on the temperature. The capacitors should be selected and designed in taking the temperature into consideration.</li> </ol> <p>2-2. Operating voltage</p> <ol style="list-style-type: none"> <li>1) Operating voltage across the terminals should be below the rated voltage.            When AC and DC are super imposed, <math>V_{0-P}</math> must be below the rated voltage.            — (1) and (2)            AC or pulse with overshooting, <math>V_{P-P}</math> must be below the rated voltage.            — (3), (4) and (5)</li> </ol> <p>When the voltage is started to apply to the circuit or it is stopped applying, the irregular voltage may be generated for a transit period because of resonance or switching. Be sure to use the capacitors within rated voltage containing these Irregular voltage.</p> <table border="1" data-bbox="478 1456 1452 2016"> <thead> <tr> <th data-bbox="478 1456 670 1500">Voltage</th> <th data-bbox="670 1456 925 1500">(1) DC voltage</th> <th data-bbox="925 1456 1181 1500">(2) DC+AC voltage</th> <th data-bbox="1181 1456 1452 1500">(3) AC voltage</th> </tr> </thead> <tbody> <tr> <td data-bbox="478 1500 670 1724">Positional Measurement (Rated voltage)</td> <td data-bbox="670 1500 925 1724">  </td> <td data-bbox="925 1500 1181 1724">  </td> <td data-bbox="1181 1500 1452 1724">  </td> </tr> <tr> <th data-bbox="478 1724 670 1769">Voltage</th> <th data-bbox="670 1724 925 1769">(4) Pulse voltage (A)</th> <th data-bbox="925 1724 1181 1769">(5) Pulse voltage (B)</th> <td></td> </tr> <tr> <td data-bbox="478 1769 670 2016">Positional Measurement (Rated voltage)</td> <td data-bbox="670 1769 925 2016">  </td> <td data-bbox="925 1769 1181 2016">  </td> <td></td> </tr> </tbody> </table>	Voltage	(1) DC voltage	(2) DC+AC voltage	(3) AC voltage	Positional Measurement (Rated voltage)				Voltage	(4) Pulse voltage (A)	(5) Pulse voltage (B)		Positional Measurement (Rated voltage)			
Voltage	(1) DC voltage	(2) DC+AC voltage	(3) AC voltage															
Positional Measurement (Rated voltage)																		
Voltage	(4) Pulse voltage (A)	(5) Pulse voltage (B)																
Positional Measurement (Rated voltage)																		

No.	Process	Condition
2	Circuit design ⚠ Caution	<p>2) Even below the rated voltage, if repetitive high frequency AC or pulse is applied, the reliability of the capacitors may be reduced.</p> <p>3) The effective capacitance will vary depending on applied DC and AC voltages. The capacitors should be selected and designed in taking the voltages into consideration.</p> <p>2-3. Frequency When the capacitors are used in AC and/or pulse voltages, the capacitors may vibrate themselves and generate audible sound.</p>

3	Designing P.C.board	<p>The amount of solder at the terminations has a direct effect on the reliability of the capacitor.</p> <p>1) The greater the amount of solder, the higher the stress on the chip capacitor, and the more likely that it will break. When designing a P.C.board, determine the shape and size of the solder lands to have proper amount of solder on the terminations.</p> <p>2) Avoid using common solder land for multiple terminations and provide individual solder land for each terminations.</p> <p>3) Size and recommended land dimensions.</p>
---	---------------------	--

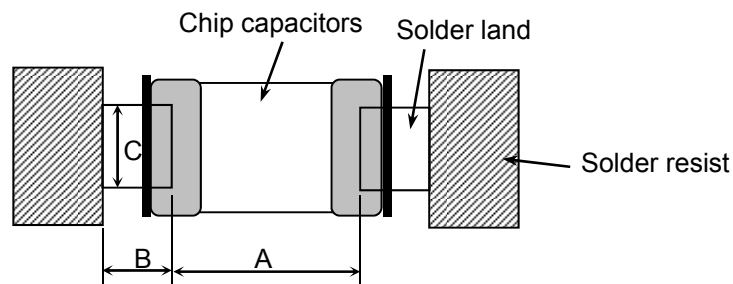

Reflow soldering

		(mm)		
Type	Symbol	CKG32K	CKG45K	CKG57K
A		2.0~2.2	3.3~3.7	3.9~4.3
B		1.1~1.3	1.2~1.5	1.5~2.0
C		2.3~2.5	2.7~3.2	4.5~5.0

Type	Symbol	CKG45N	CKG57N
A		3.3~3.7	3.9~4.3
B		1.2~1.5	1.5~2.0
C		2.7~3.2	4.5~5.0

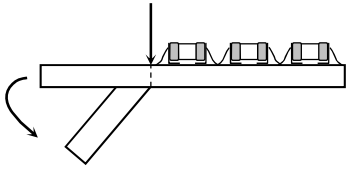
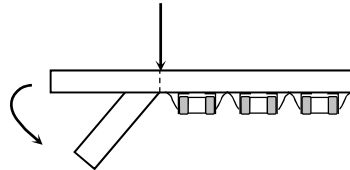
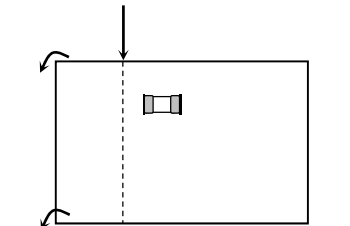
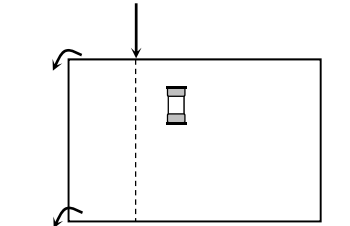
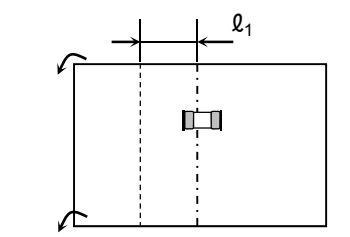
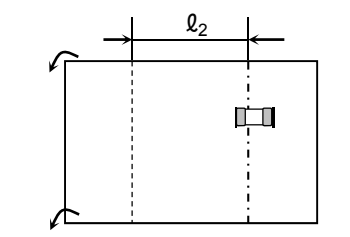
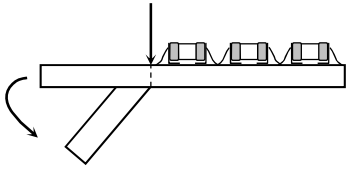
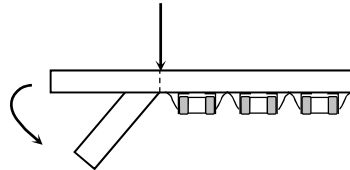
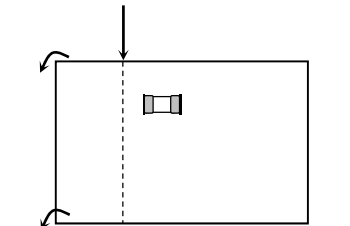
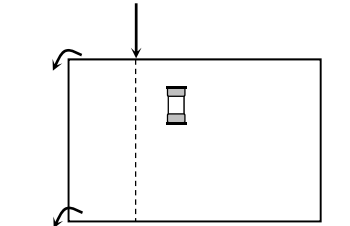
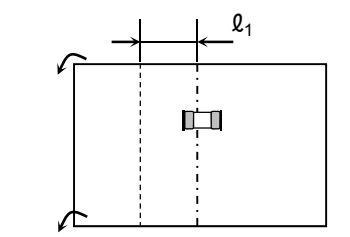
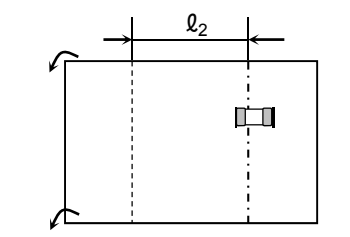
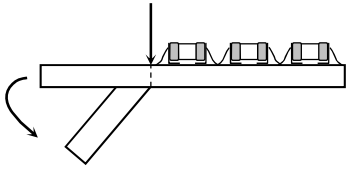
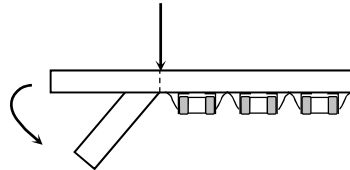
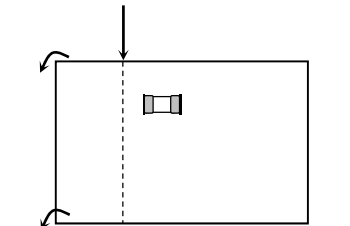
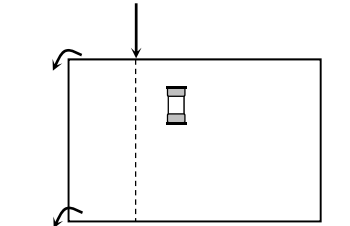
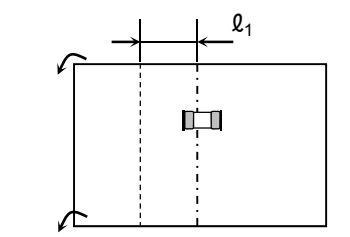
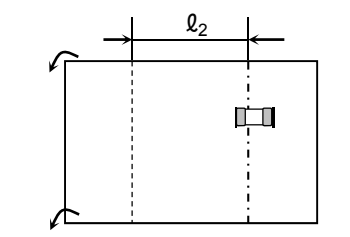
No.	Process	Condition												
3	Designing P.C.board	<p data-bbox="438 230 1109 264">4) Recommended chip capacitor layout is as following.</p> <table border="1" data-bbox="478 347 1436 1765"> <thead> <tr> <th data-bbox="478 347 662 421"></th> <th data-bbox="662 347 1045 421">Disadvantage against bending stress</th> <th data-bbox="1045 347 1436 421">Advantage against bending stress</th> </tr> </thead> <tbody> <tr> <td data-bbox="478 421 662 840">Mounting face</td> <td data-bbox="662 421 1045 840"> <p data-bbox="750 470 957 504">Perforation or slit</p>  <p data-bbox="726 728 981 795">Break P.C.board with mounted side up.</p> </td> <td data-bbox="1045 421 1436 840"> <p data-bbox="1133 470 1340 504">Perforation or slit</p>  <p data-bbox="1125 728 1380 795">Break P.C.board with mounted side down.</p> </td> </tr> <tr> <td data-bbox="478 840 662 1288">Chip arrangement (Direction)</td> <td data-bbox="662 840 1045 1288"> <p data-bbox="750 952 957 985">Perforation or slit</p>  </td> <td data-bbox="1045 840 1436 1288"> <p data-bbox="1133 952 1340 985">Perforation or slit</p>  </td> </tr> <tr> <td data-bbox="478 1288 662 1765">Distance from slit</td> <td data-bbox="662 1288 1045 1765"> <p data-bbox="678 1288 1029 1321">Closer to slit is higher stress</p>  <p data-bbox="877 1657 1005 1691"><math>(l_1 &lt; l_2)</math></p> </td> <td data-bbox="1045 1288 1436 1765"> <p data-bbox="1061 1288 1412 1321">Away from slit is less stress</p>  <p data-bbox="1260 1657 1388 1691"><math>(l_1 &lt; l_2)</math></p> </td> </tr> </tbody> </table>		Disadvantage against bending stress	Advantage against bending stress	Mounting face	<p data-bbox="750 470 957 504">Perforation or slit</p>  <p data-bbox="726 728 981 795">Break P.C.board with mounted side up.</p>	<p data-bbox="1133 470 1340 504">Perforation or slit</p>  <p data-bbox="1125 728 1380 795">Break P.C.board with mounted side down.</p>	Chip arrangement (Direction)	<p data-bbox="750 952 957 985">Perforation or slit</p> 	<p data-bbox="1133 952 1340 985">Perforation or slit</p> 	Distance from slit	<p data-bbox="678 1288 1029 1321">Closer to slit is higher stress</p>  <p data-bbox="877 1657 1005 1691"><math>(l_1 &lt; l_2)</math></p>	<p data-bbox="1061 1288 1412 1321">Away from slit is less stress</p>  <p data-bbox="1260 1657 1388 1691"><math>(l_1 &lt; l_2)</math></p>
	Disadvantage against bending stress	Advantage against bending stress												
Mounting face	<p data-bbox="750 470 957 504">Perforation or slit</p>  <p data-bbox="726 728 981 795">Break P.C.board with mounted side up.</p>	<p data-bbox="1133 470 1340 504">Perforation or slit</p>  <p data-bbox="1125 728 1380 795">Break P.C.board with mounted side down.</p>												
Chip arrangement (Direction)	<p data-bbox="750 952 957 985">Perforation or slit</p> 	<p data-bbox="1133 952 1340 985">Perforation or slit</p> 												
Distance from slit	<p data-bbox="678 1288 1029 1321">Closer to slit is higher stress</p>  <p data-bbox="877 1657 1005 1691"><math>(l_1 &lt; l_2)</math></p>	<p data-bbox="1061 1288 1412 1321">Away from slit is less stress</p>  <p data-bbox="1260 1657 1388 1691"><math>(l_1 &lt; l_2)</math></p>												

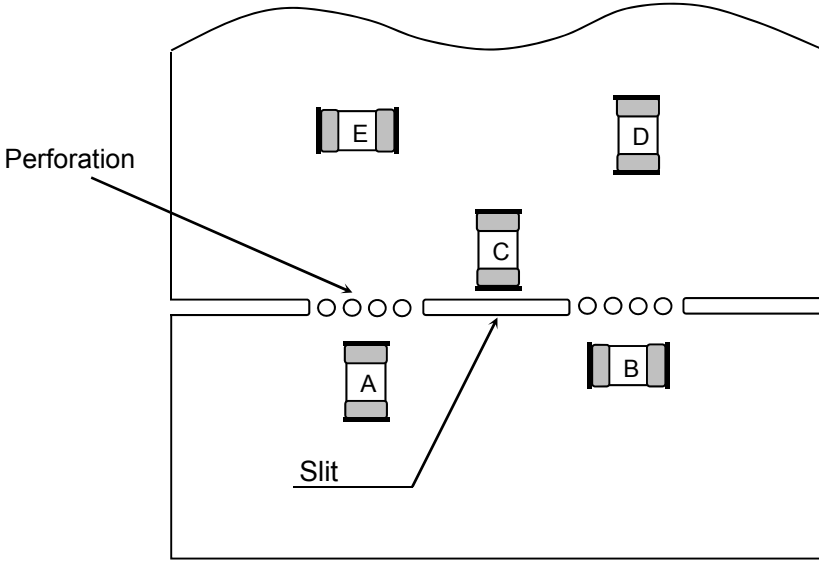
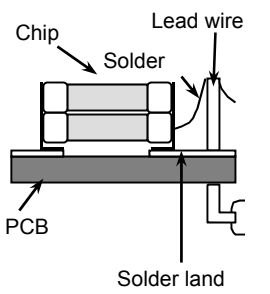
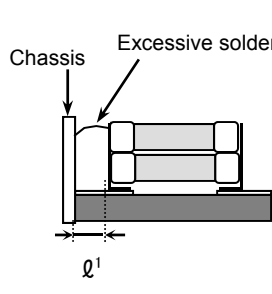
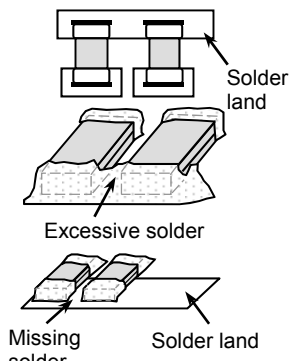
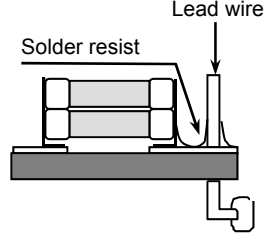
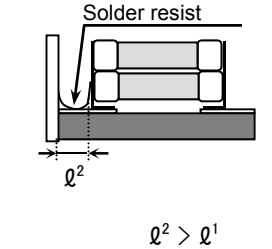
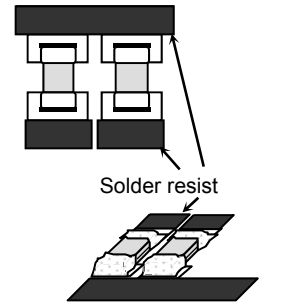
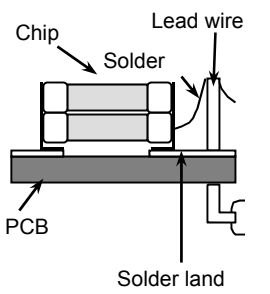
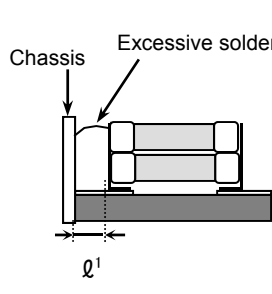
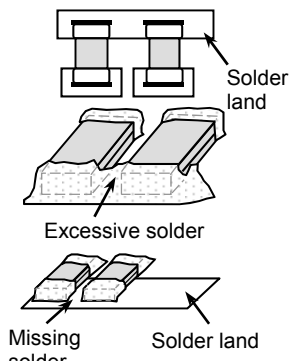
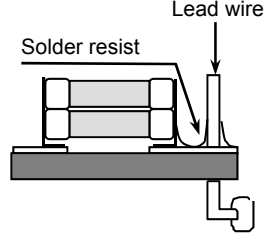
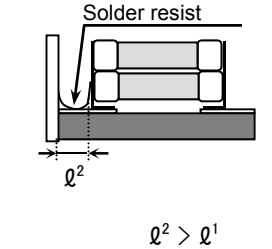
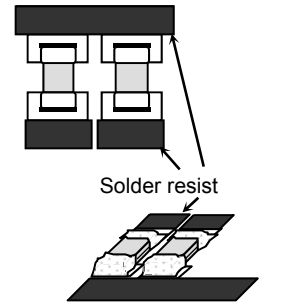
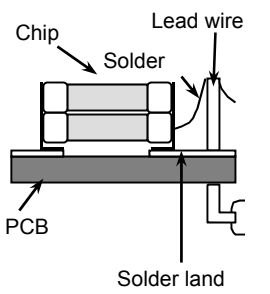
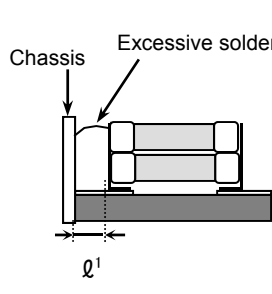
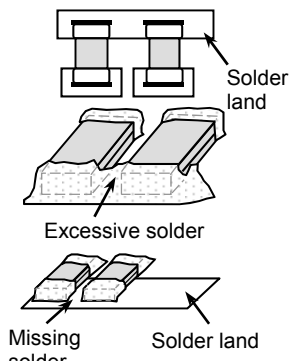
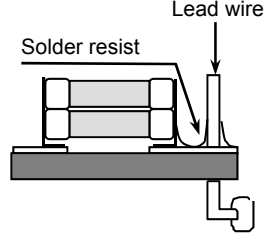
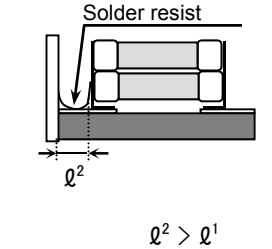
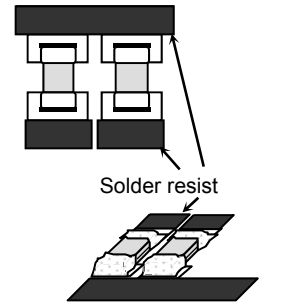
No.	Process	Condition												
3	Designing P.C.board	<p>5) Mechanical stress varies according to location of chip capacitors on the P.C.board.</p>  <p>The stress in capacitors is in the following order.  <math>A &gt; B = C &gt; D &gt; E</math></p>												
		<p>6) Layout recommendation</p> <table border="1"> <thead> <tr> <th data-bbox="403 1030 550 1142">Example</th> <th data-bbox="550 1030 853 1142">Use of common solder land</th> <th data-bbox="853 1030 1157 1142">Soldering with chassis</th> <th data-bbox="1157 1030 1497 1142">Use of common solder land with other SMD</th> </tr> </thead> <tbody> <tr> <td data-bbox="403 1142 550 1523">Need to avoid</td> <td data-bbox="550 1142 853 1523">  </td> <td data-bbox="853 1142 1157 1523">  </td> <td data-bbox="1157 1142 1497 1523">  </td> </tr> <tr> <td data-bbox="403 1523 550 1937">Recommendation</td> <td data-bbox="550 1523 853 1937">  </td> <td data-bbox="853 1523 1157 1937">  <p><math>q^2 &gt; q^1</math></p> </td> <td data-bbox="1157 1523 1497 1937">  </td> </tr> </tbody> </table>	Example	Use of common solder land	Soldering with chassis	Use of common solder land with other SMD	Need to avoid				Recommendation		 <p><math>q^2 &gt; q^1</math></p>	
Example	Use of common solder land	Soldering with chassis	Use of common solder land with other SMD											
Need to avoid														
Recommendation		 <p><math>q^2 &gt; q^1</math></p>												

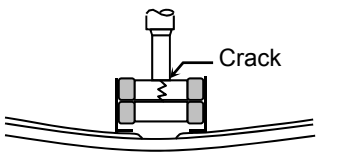
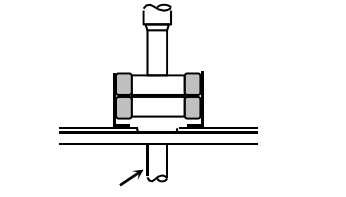
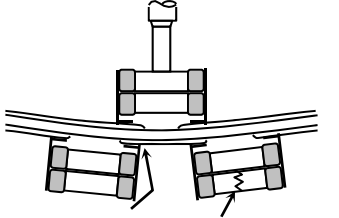
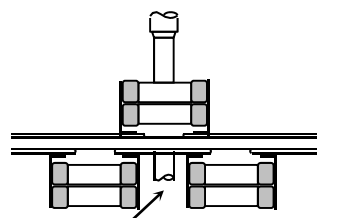
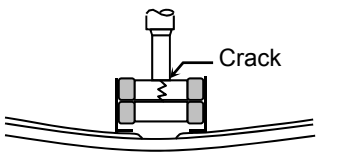
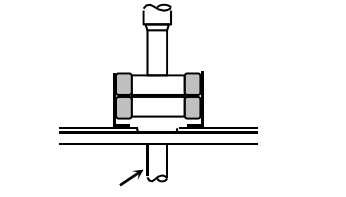
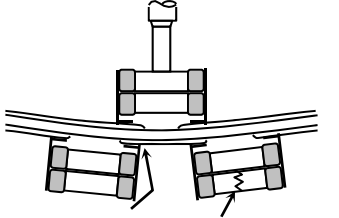
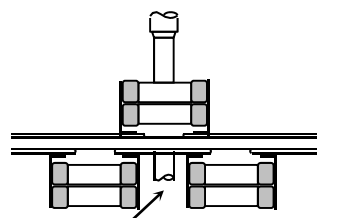
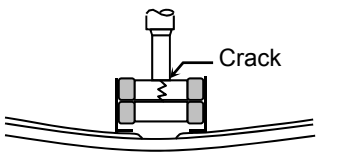
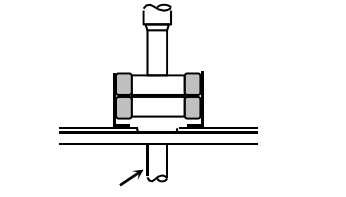
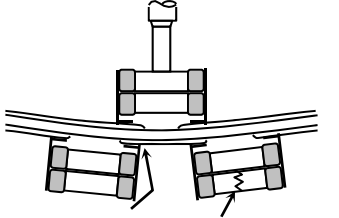
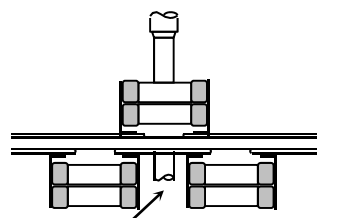
No.	Process	Condition									
4	Mounting	<p>4-1. Stress from mounting head If the mounting head is adjusted too low, it may induce excessive stress in the chip capacitor to result in cracking. Please take following precautions.</p> <ol style="list-style-type: none"> <li>1) Adjust the bottom dead center of the mounting head to reach on the P.C.board surface and not press it.</li> <li>2) Adjust the mounting head pressure to be 1 to 3N of static weight.</li> <li>3) To minimize the impact energy from mounting head, it is important to provide support from the bottom side of the P.C.board. See following examples.</li> </ol> <table border="1" data-bbox="485 618 1437 1182"> <thead> <tr> <th data-bbox="485 618 687 674"></th> <th data-bbox="687 618 1059 674">Not recommended</th> <th data-bbox="1059 618 1437 674">Recommended</th> </tr> </thead> <tbody> <tr> <td data-bbox="485 674 687 920">Single-sided mounting</td> <td data-bbox="687 674 1059 920">  <p>Crack</p> </td> <td data-bbox="1059 674 1437 920">  <p>Support pin</p> </td> </tr> <tr> <td data-bbox="485 920 687 1182">Double-sides mounting</td> <td data-bbox="687 920 1059 1182">  <p>Solder peeling Crack</p> </td> <td data-bbox="1059 920 1437 1182">  <p>Support pin</p> </td> </tr> </tbody> </table> <p>when the centering jaw is worn out, it may give mechanical impact on the capacitor to cause crack. Please control the close up dimension of the centering jaw and provide sufficient preventive maintenance and replacement of it.</p>		Not recommended	Recommended	Single-sided mounting	 <p>Crack</p>	 <p>Support pin</p>	Double-sides mounting	 <p>Solder peeling Crack</p>	 <p>Support pin</p>
	Not recommended	Recommended									
Single-sided mounting	 <p>Crack</p>	 <p>Support pin</p>									
Double-sides mounting	 <p>Solder peeling Crack</p>	 <p>Support pin</p>									

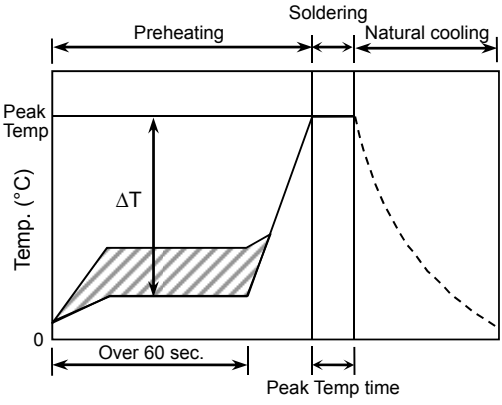
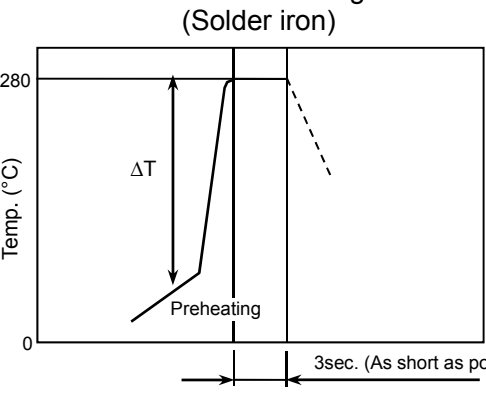
No.	Process	Condition														
5	Soldering	<p>5-1. Flux selection Flux can seriously affect the performance of capacitors. Confirm the following to select the appropriate flux.</p> <ol style="list-style-type: none"> <li>1) It is recommended to use a mildly activated rosin flux ( less than 0.1wt% chlorine ). Strong flux is not recommended.</li> <li>2) Excessive flux must be avoided. Please provide proper amount of flux.</li> <li>3) When water-soluble flux is used, enough washing is necessary.</li> </ol> <p>5-2. Recommended soldering profile by various methods Reflow soldering condition</p> <ol style="list-style-type: none"> <li>1) Soldering condition (Preheating temperature, soldering temperature and these times) is limited to reflow soldering method which is stipulated on the specification.</li> <li>2) Chips should be mounted, shortly after a solder is on a P.C.Board.</li> <li>3) Temperature of metal cap surface must not exceed 250°C. (Metal frames are jointed by high temp solder, however the solder temperature must be less than 250°C to avoid melting the solder.)</li> </ol> <div style="display: flex; justify-content: space-around; align-items: flex-start;"> <div style="text-align: center;"> <p>Reflow soldering</p>  <p>The graph shows temperature (°C) on the y-axis and time on the x-axis. It is divided into three phases: Preheating (shaded area, duration 'Over 60 sec.'), Soldering (constant peak temperature, duration 'Peak Temp time'), and Natural cooling (dashed line). A temperature difference <math>\Delta T</math> is indicated between the preheating level and the peak temperature.</p> </div> <div style="text-align: center;"> <p>Manual soldering (Solder iron)</p>  <p>The graph shows temperature (°C) on the y-axis and time on the x-axis. It shows a 'Preheating' phase followed by a sharp peak reaching 280°C. The peak duration is marked as '3sec. (As short as possible)'. A temperature difference <math>\Delta T</math> is also indicated.</p> </div> </div> <p>5-3. Recommended soldering peak temp and peak temp duration</p> <table border="1" style="margin-left: auto; margin-right: auto;"> <thead> <tr> <th rowspan="2" style="text-align: center;">Temp./Duration</th> <th colspan="2" style="text-align: center;">Reflow soldering</th> </tr> <tr> <th style="text-align: center;">Peak temp(°C)</th> <th style="text-align: center;">Duration(sec.)</th> </tr> </thead> <tbody> <tr> <td style="text-align: center;">Solder</td> <td></td> <td></td> </tr> <tr> <td style="text-align: center;">Sn-Pb Solder</td> <td style="text-align: center;">230 max.</td> <td style="text-align: center;">20 max.</td> </tr> <tr> <td style="text-align: center;">Lead Free Solder</td> <td style="text-align: center;">250 max.</td> <td style="text-align: center;">10 max.</td> </tr> </tbody> </table> <p>Recommended solder compositions Sn-37Pb (Sn-Pb solder) Sn-3.0Ag-0.5Cu (Lead Free Solder)</p>	Temp./Duration	Reflow soldering		Peak temp(°C)	Duration(sec.)	Solder			Sn-Pb Solder	230 max.	20 max.	Lead Free Solder	250 max.	10 max.
Temp./Duration	Reflow soldering															
	Peak temp(°C)	Duration(sec.)														
Solder																
Sn-Pb Solder	230 max.	20 max.														
Lead Free Solder	250 max.	10 max.														

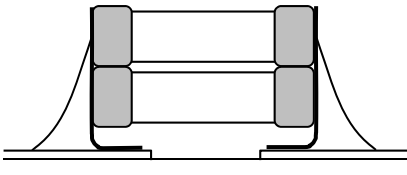
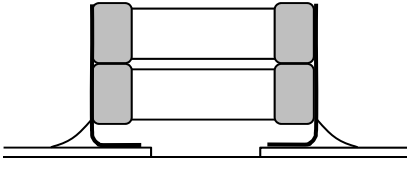
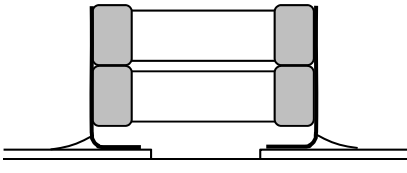
No.	Process	Condition														
5	Soldering	<p>5-4. Avoiding thermal shock</p> <p>1) Preheating condition</p> <table border="1" data-bbox="560 253 997 383"> <thead> <tr> <th>Soldering</th> <th>Temp. (°C)</th> </tr> </thead> <tbody> <tr> <td>Reflow soldering</td> <td><math>\Delta T \leq 130</math></td> </tr> <tr> <td>Manual soldering</td> <td><math>\Delta T \leq 130</math></td> </tr> </tbody> </table> <p>2) Cooling condition Natural cooling using air is recommended. If the chips are dipped into a solvent for cleaning, the temperature difference (<math>\Delta T</math>) must be less than 100°C.</p> <p>5-5. Amount of solder Excessive solder will induce higher tensile force in chip capacitor when temperature changes and it may result in chip cracking. In sufficient solder may detach the capacitor from the P.C.board.</p> <div style="display: flex; justify-content: space-between; align-items: center; margin-top: 20px;"> <div data-bbox="518 752 641 808" style="text-align: center;">Excessive solder</div> <div data-bbox="699 714 1107 887" style="text-align: center;">  </div> <div data-bbox="1129 752 1452 808" style="text-align: center;">Higher tensile force in chip capacitor to cause crack</div> </div> <hr/> <div style="display: flex; justify-content: space-between; align-items: center; margin-top: 20px;"> <div data-bbox="518 994 641 1025" style="text-align: center;">Adequate</div> <div data-bbox="699 936 1107 1108" style="text-align: center;">  </div> </div> <hr/> <div style="display: flex; justify-content: space-between; align-items: center; margin-top: 20px;"> <div data-bbox="518 1205 641 1261" style="text-align: center;">Insufficient solder</div> <div data-bbox="699 1151 1107 1323" style="text-align: center;">  </div> <div data-bbox="1129 1178 1425 1285" style="text-align: center;">Low robustness may cause contact failure or chip capacitor comes off the P.C.board.</div> </div> <hr/> <p>5-6. Solder repair by solder iron</p> <p>1) Selection of the soldering iron tip Tip temperature of solder iron varies by its type, P.C.board material and solder land size. The higher the tip temperature, the quicker the operation. However, heat shock may cause a crack in the chip capacitors. Please make sure the tip temp. before soldering and keep the peak temp and time in accordance with following recommended condition. (Please preheat the chip capacitors with the condition in 5-4 to avoid the thermal shock.)</p> <p>Recommended solder iron condition (Sn-Pb Solder and Lead Free Solder)</p> <table border="1" data-bbox="560 1686 1398 1794"> <thead> <tr> <th>Temp. (°C)</th> <th>Duration (sec.)</th> <th>Wattage (W)</th> <th>Shape (mm)</th> </tr> </thead> <tbody> <tr> <td>280 max.</td> <td>3 max.</td> <td>20 max.</td> <td>Ø 3.0 max.</td> </tr> </tbody> </table> <p>2) Direct contact of the soldering iron with ceramic dielectric of chip capacitors may cause crack. Do not touch the ceramic dielectric and the terminations by solder iron.</p> <p>5-7. Sn-Zn solder Sn-Zn solder affects product reliability. Please contact TDK in advance when utilize Sn-Zn solder.</p>	Soldering	Temp. (°C)	Reflow soldering	$\Delta T \leq 130$	Manual soldering	$\Delta T \leq 130$	Temp. (°C)	Duration (sec.)	Wattage (W)	Shape (mm)	280 max.	3 max.	20 max.	Ø 3.0 max.
Soldering	Temp. (°C)															
Reflow soldering	$\Delta T \leq 130$															
Manual soldering	$\Delta T \leq 130$															
Temp. (°C)	Duration (sec.)	Wattage (W)	Shape (mm)													
280 max.	3 max.	20 max.	Ø 3.0 max.													

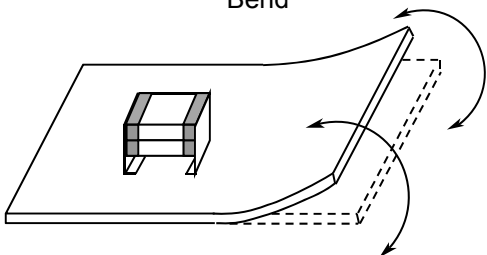
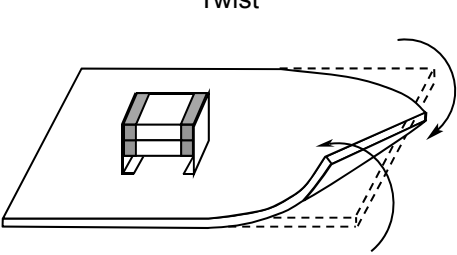
No.	Process	Condition
5	Soldering	5-8. Countermeasure for tombstone The misalignment between the mounted positions of the capacitors and the land patterns should be minimized. The tombstone phenomenon may occur especially the capacitors are mounted (in longitudinal direction) in the same direction of the reflow soldering. (Refer to JEITA RCR-2335C Annex A (Informative) Recommendations to prevent the tombstone phenomenon)
6	Cleaning	1) If an unsuitable cleaning fluid is used, flux residue or some foreign articles may stick to chip capacitor surface to deteriorate especially the insulation resistance.  2) If cleaning condition is not suitable, it may damage the chip capacitor. 2)-1. Insufficient washing (1) Terminal electrodes may corrode by Halogen in the flux.  (2) Halogen in the flux may adhere on the surface of capacitor, and lower the insulation resistance.  (3) Water soluble flux has higher tendency to have above mentioned problems (1) and (2).  2)-2. Excessive washing  When ultrasonic cleaning is used, excessively high ultrasonic energy output can affect the connection between the ceramic chip capacitor's body and the terminal electrode. To avoid this, following is the recommended condition. Power : 20W/lmax. Frequency : 40kHz max. Washing time : 5 minutes max.  2)-3. If the cleaning fluid is contaminated, density of Halogen increases, and it may bring the same result as insufficient cleaning.
7	Coating and molding of the P.C.board	1) When the P.C.board is coated, please verify the quality influence on the product.  2) Please verify carefully that there is no harmful decomposing or reaction gas emission during curing which may damage the chip capacitor.  3) Please verify the curing temperature.
8	Handling after chip mounted ⚠ Caution	1) Please pay attention not to bend or distort the P.C.board after soldering in handling otherwise the chip capacitor may crack.  <div style="display: flex; justify-content: space-around; align-items: center;"> <div style="text-align: center;"> <p>Bend</p>  </div> <div style="text-align: center;"> <p>Twist</p>  </div> </div>

No.	Process	Condition																
8	Handling after chip mounted ⚠ Caution	<p>2) Printed circuit board cropping should not be carried out by hand, but by using the proper tooling. Printed circuit board cropping should be carried out using a board cropping jig as shown in the following figure or a board cropping apparatus to prevent inducing mechanical stress on the board.</p> <p>(1) Example of a board cropping jig</p> <p>Recommended example: The board should be pushed from the back side, close to the cropping jig so that the board is not bent and the stress applied to the capacitor is compressive.</p> <p>Unrecommended example: If the pushing point is far from the cropping jig and the pushing direction is from the front side of the board, large tensile stress is applied to the capacitor, which may cause cracks.</p> <div style="display: flex; justify-content: space-around;"> <div data-bbox="443 539 730 808"> <p>Outline of jig</p> </div> <div data-bbox="743 533 1422 797"> <table border="1"> <thead> <tr> <th data-bbox="743 533 1078 589">Recommended</th> <th data-bbox="1078 533 1422 589">Unrecommended</th> </tr> </thead> <tbody> <tr> <td data-bbox="743 589 1078 797"> </td> <td data-bbox="1078 589 1422 797"> </td> </tr> </tbody> </table> </div> </div> <p>(2) Example of a board cropping machine</p> <p>An outline of a printed circuit board cropping machine is shown below. The top and bottom blades are aligned with one another along the lines with the V-grooves on printed circuit board when cropping the board.</p> <p>Unrecommended example: Misalignment of blade position between top and bottom, right and left, or front and rear blades may cause a crack in the capacitor.</p> <div style="display: flex; justify-content: space-around;"> <div data-bbox="539 1093 951 1335"> <p>Outline of machine</p> </div> <div data-bbox="943 1093 1390 1317"> <p>Principle of operation</p> </div> </div> <div style="text-align: center; margin-top: 10px;"> <p>Cross-section diagram</p> </div> <table border="1" style="width: 100%; text-align: center; margin-top: 20px;"> <thead> <tr> <th data-bbox="624 1559 804 1615">Recommended</th> <th colspan="3" data-bbox="804 1559 1334 1615">Unrecommended</th> </tr> <tr> <th data-bbox="624 1615 804 1693"></th> <th data-bbox="804 1615 984 1693">Top-bottom misalignment</th> <th data-bbox="984 1615 1149 1693">Left-right misalignment</th> <th data-bbox="1149 1615 1334 1693">Front-rear misalignment</th> </tr> </thead> <tbody> <tr> <td data-bbox="624 1693 804 1984"> </td> <td data-bbox="804 1693 984 1984"> </td> <td data-bbox="984 1693 1149 1984"> </td> <td data-bbox="1149 1693 1334 1984"> </td> </tr> </tbody> </table>	Recommended	Unrecommended			Recommended	Unrecommended				Top-bottom misalignment	Left-right misalignment	Front-rear misalignment				
Recommended	Unrecommended																	
Recommended	Unrecommended																	
	Top-bottom misalignment	Left-right misalignment	Front-rear misalignment															

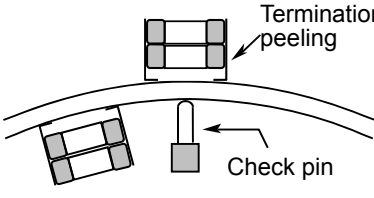
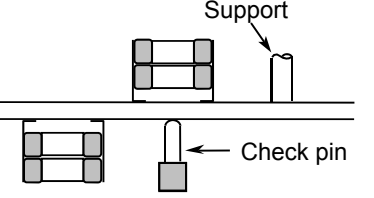
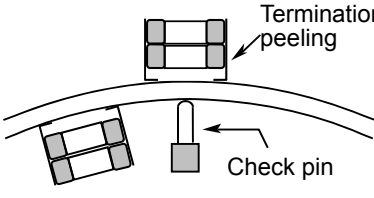
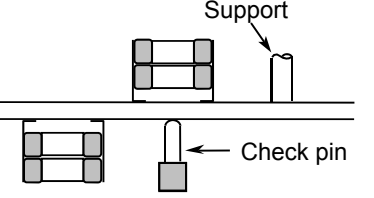
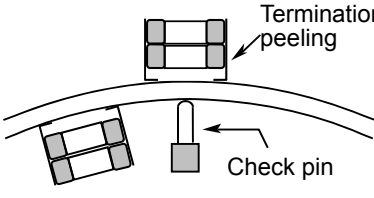
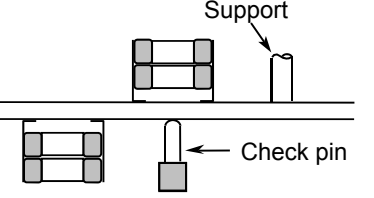
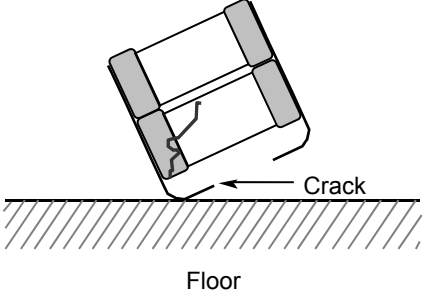
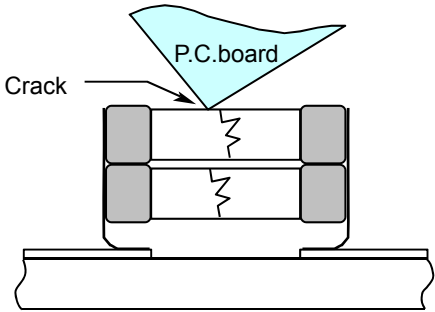
No.	Process	Condition						
8	Handling after chip mounted ⚠ Caution	<p>2) When functional check of the P.C.board is performed, check pin pressure tends to be adjusted higher for fear of loose contact. But if the pressure is excessive and bend the P.C.board, it may crack the chip capacitor or peel the terminations off. Please adjust the check pins not to bend the P.C.board.</p> <table border="1" data-bbox="486 365 1485 712"> <thead> <tr> <th data-bbox="486 365 643 427">Item</th> <th data-bbox="643 365 1066 427">Not recommended</th> <th data-bbox="1066 365 1485 427">Recommended</th> </tr> </thead> <tbody> <tr> <td data-bbox="486 427 643 712">Board bending</td> <td data-bbox="643 427 1066 712">  </td> <td data-bbox="1066 427 1485 712">  </td> </tr> </tbody> </table>	Item	Not recommended	Recommended	Board bending		
Item	Not recommended	Recommended						
Board bending								
9	Handling of loose chip capacitor	<p>1) If dropped the chip capacitor may crack. Once dropped do not use it. Especially, the large case sized chip capacitors are tendency to have cracks easily, so please handle with care.</p>  <p>2) Piling the P.C.board after mounting for storage or handling, the corner of the P.C. board may hit the chip capacitor of another board to cause crack.</p> 						
10	Capacitance aging	<p>The capacitors have aging in the capacitance. They may not be used in precision time constant circuit. In case of the time constant circuit, the evaluation should be done well.</p>						
11	Estimated life and estimated failure rate of capacitors	<p>As per the estimated life and the estimated failure rate depend on the temperature and the voltage. This can be calculated by the equation described in JEITA RCR-2335C Annex F (Informative) Calculation of the estimated lifetime and the estimated failure rate ( Voltage acceleration coefficient : 3 multiplication rule, Temperature acceleration coefficient : 10°C rule)            The failure rate can be decreased by reducing the temperature and the voltage but they will not be guaranteed.</p>						

No.	Process	Condition
12	Caution during operation of equipment	<p>1) A capacitor shall not be touched directly with bare hands during operation in order to avoid electric shock. Electric energy held by the capacitor may be discharged through the human body when touched with a bare hand. Even when the equipment is off, a capacitor may stay charged. The capacitor should be handled after being completely discharged using a resistor.</p> <p>2) The terminals of a capacitor shall not be short-circuited by any accidental contact with a conductive object. A capacitor shall not be exposed to a conductive liquid such as an acid or alkali solution. A conductive object or liquid, such as acid and alkali, between the terminals may lead to the breakdown of a capacitor due to short circuit</p> <p>3) Confirm that the environment to which the equipment will be exposed during transportation and operation meets the specified conditions. Do not to use the equipment in the following environments.</p> <p>(1) Environment where a capacitor is splattered with water or oil  (2) Environment where a capacitor is exposed to direct sunlight  (3) Environment where a capacitor is exposed to Ozone, ultraviolet rays or radiation  (4) Environment where a capacitor exposed to corrosive gas(e.g. hydrogen sulfide, sulfur dioxide, chlorine. ammonia gas etc.)  (5) Environment where a capacitor exposed to vibration or mechanical shock exceeding the specified limits.  (6) Atmosphere change with causes condensation</p>
13	Others ⚠ Caution	<p>The products listed on this specification sheet are intended for use in general electronic equipment (AV equipment, telecommunications equipment, home appliances, amusement equipment, computer equipment, personal equipment, office equipment, measurement equipment, industrial robots) under a normal operation and use condition.</p> <p>The products are not designed or warranted to meet the requirements of the applications listed below, whose performance and/or quality require a more stringent level of safety or reliability, or whose failure, malfunction or trouble could cause serious damage to society, person or property. Please understand that we are not responsible for any damage or liability caused by use of the products in any of the applications below or for any other use exceeding the range or conditions set forth in this specification sheet. If you intend to use the products in the applications listed below or if you have special requirements exceeding the range or conditions set forth in this specification, please contact us.</p> <p>(1) Aerospace/Aviation equipment  (2) Transportation equipment (cars, electric trains, ships, etc.)  (3) Medical equipment (Excepting Pharmaceutical Affairs Law classification Class1,2)  (4) Power-generation control equipment  (5) Atomic energy-related equipment  (6) Seabed equipment  (7) Transportation control equipment  (8) Public information-processing equipment  (9) Military equipment  (10) Electric heating apparatus, burning equipment  (11) Disaster prevention/crime prevention equipment  (12) Safety equipment  (13) Other applications that are not considered general-purpose applications</p> <p>When designing your equipment even for general-purpose applications, you are kindly requested to take into consideration securing protection circuit/device or providing backup circuits in your equipment.</p>

## 12. TAPE PACKAGING SPECIFICATION

### 1. CONSTRUCTION AND DIMENSION OF TAPING

#### 1-1. Dimensions of carrier tape

Dimensions of tape shall be according to Appendix 3, 4.

#### 1-2. Bulk part and leader of taping

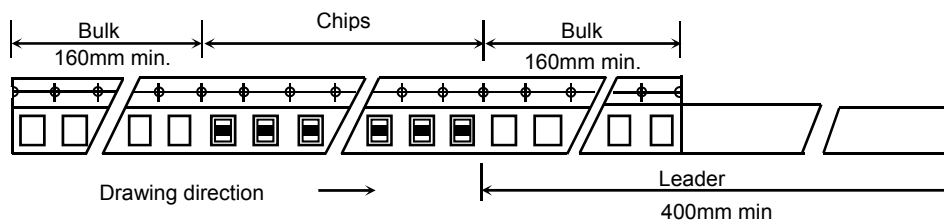

#### 1-3. Dimensions of reel

Dimensions of  $\varnothing 178$  reel shall be according to Appendix 5.

Dimensions of  $\varnothing 330$  reel shall be according to Appendix 6.

#### 1-4. Structure of taping

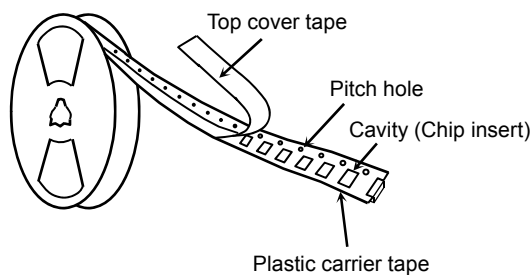

## 2. CHIP QUANTITY

Please refer to the table A in the end of the specification.

### 3. PERFORMANCE SPECIFICATIONS

3-1. Fixing peeling strength (top tape)

0.05-0.7N. (See the following figure.)

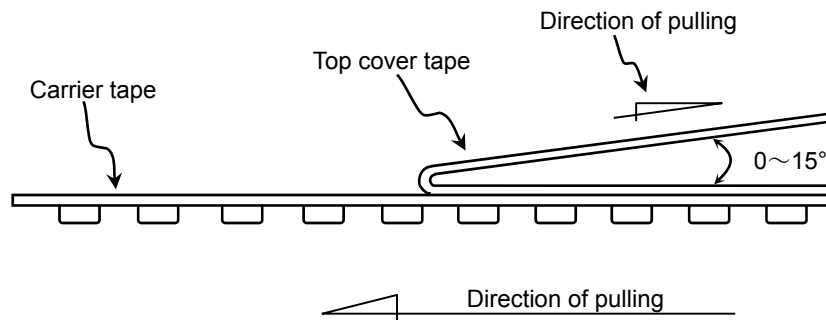

3-2. Carrier tape shall be flexible enough to be wound around a minimum radius of 30mm with components in tape.

3-3. The missing of components shall be less than 0.1%

3-4. When get cover tape off, there shall not be difficulties by unfitting clearance, burrs and crushes of cavities, also the sprocket holes shall not be covered by absorbing dust into the suction nozzle.

### Appendix 3

#### Plastic Tape

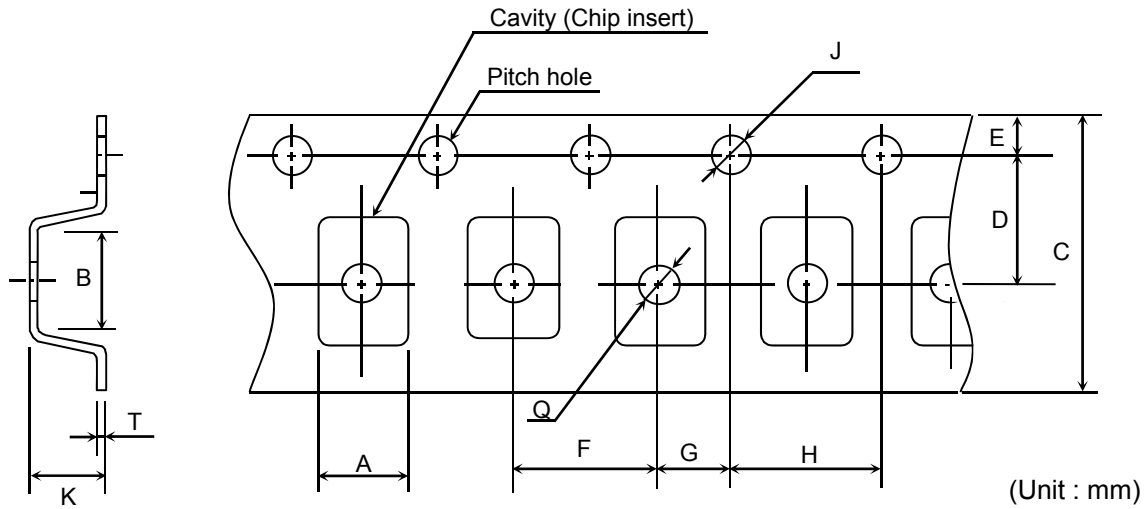

Symbol Type	A	B	C	D	E	F
CKG32K	( 3.00 )	( 3.90 )	12.0 ± 0.25	5.50 ± 0.05	1.75 ± 0.10	4.00 ± 0.10

  

Symbol Type	G	H	J	K	T	Q
CKG32K	2.00 ± 0.10	4.00 ± 0.10	∅ 1.5 <sup>+0.10</sup> <sub>0</sub>	3.75 max.	0.50 ± 0.05	∅ 1.65 ± 0.10

( ) Reference value.

### Appendix 4

#### Plastic Tape

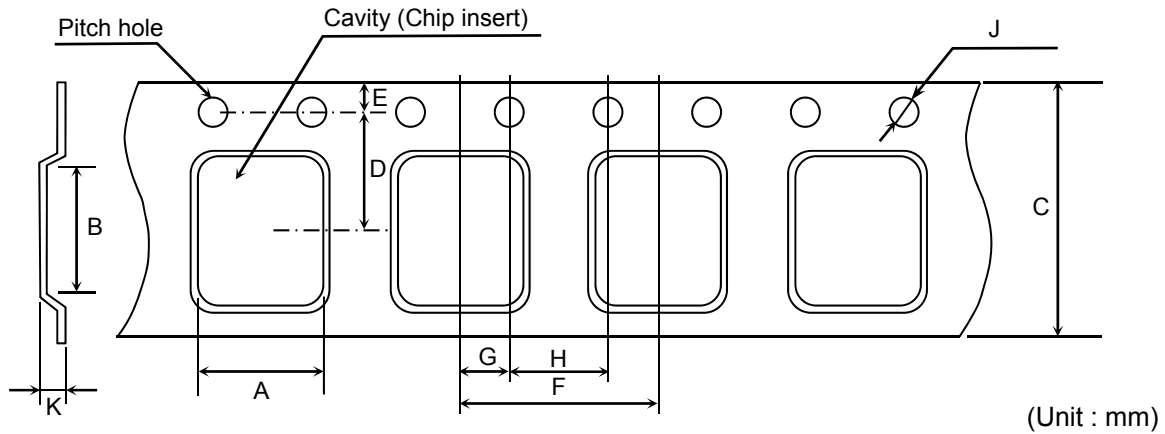

Symbol Type	A	B	C	D	E	F
CKG45K	( 3.90 )	( 5.60 )	12.0 ± 0.30	5.50 ± 0.10	1.75 ± 0.10	8.00 ± 0.10
CKG45N						
CKG57K	( 5.60 )	( 6.60 )	16.0 ± 0.30	7.50 ± 0.10	1.75 ± 0.10	8.00 ± 0.10
CKG57N						

  

Symbol Type	G	H	J	K
CKG45K	2.00 ± 0.10	4.00 ± 0.10	∅ 1.5 <sup>+0.10</sup> <sub>0</sub>	3.75 max.
CKG45N				6.15 max.
CKG57K	2.00 ± 0.10	4.00 ± 0.10	∅ 1.5 <sup>+0.10</sup> <sub>0</sub>	4.15 max.
CKG57N				6.15 max.

( ) Reference value.

## Appendix 5

(Material : Polystyrene)

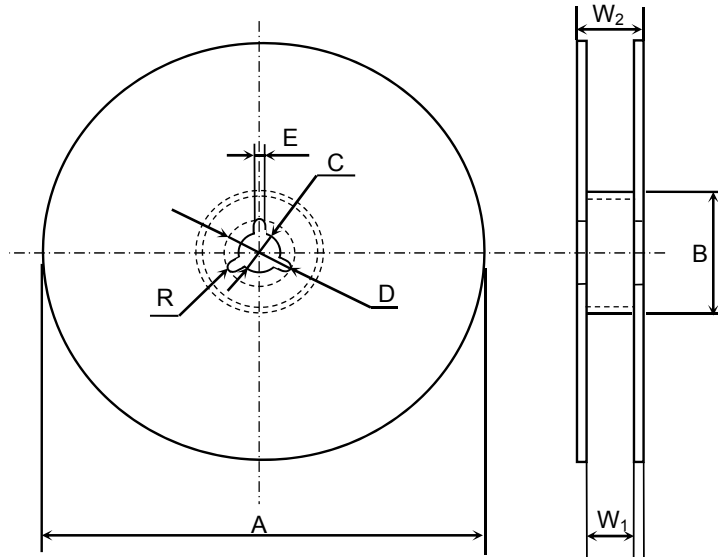

(Unit : mm)

Symbol Dimension	A	B	C	D	E	W <sub>1</sub>
CKG32K	$\varnothing 178 \pm 2.0$	$\varnothing 60 \pm 2.0$	$\varnothing 13 \pm 0.5$	$\varnothing 21 \pm 0.8$	$2.0 \pm 0.5$	$13.0 \pm 0.3$

Symbol Dimension	W <sub>2</sub>	R
CKG32K	$17.0 \pm 1.4$	1.0

## Appendix 6

(Material : Polystyrene)

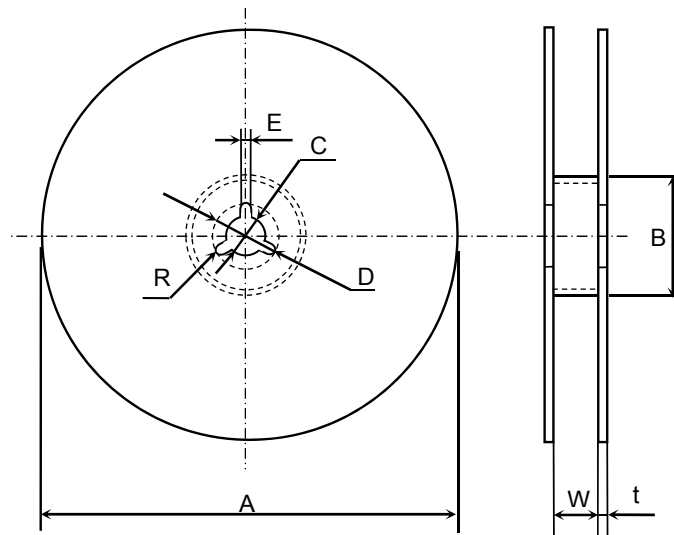

(Unit : mm)

Symbol Dimension	A	B	C	D	E	W
CKG32K	$\varnothing 382$ max. (Nominal $\varnothing 330$ )	$\varnothing 50$ min.	$\varnothing 13 \pm 0.5$	$\varnothing 21 \pm 0.8$	$2.0 \pm 0.5$	$14.0 \pm 1.5$
CKG45K, CKG45N						$13.5 \pm 1.5$
CKG57K, CKG57N						$17.5 \pm 1.5$

Symbol Dimension	t	R
CKG32	$2.0 \pm 0.5$	1.0
CKG45K, CKG45N		
CKG57K, CKG57N		