

## Technical Instructions (Basic) Brushless Motor MINAS-BL GV·GP Series

- Thank you very much for your purchase of Panasonic product.
- Please read this instruction manual carefully for proper use.
- In particular, be sure to read Safety precautions (P.E2 to E5) before use for safety.
- Keep this manual with care after reading, and read as necessary.

Be sure to give this Instruction manual to an end user.



Photo: MINAS-BL GV series 50 W

•This product is for industrial equipment. Don't use this product at general household.

### <CONTENTS>



	Page		Page
Safety Precautions .....	E2	Wiring .....	E10
Introduction.....	E6	Maintenance and inspection.....	E11
Product designation.....	E6	Compatible standards.....	E12
Name of each part.....	E7	Specifications .....	E13
Installation .....	E8	Warranty .....	E15
		After-sales service (repair) .....	Back cover

# Safety Precautions



Please observe safety precautions fully.

The following explanations are for things that must be observed in order to prevent harm to people and damage to property.

- Misuses that could result in harm or damage are shown as follows, classified according to the degree of potential harm or damage.



	<b>Danger</b>	Indicates great possibility of death or serious injury.
	<b>Caution</b>	Indicates the possibility of injury or property damage.

- The following indications show things that must be observed.

	Indicates something that must not be done.
	Indicates something that must be done.

## Danger

	<b>Do not subject the Product to water, corrosive or flammable gases, and combustibles.</b>	Failure to observe this instruction could result in fire.
	<b>Do not place combustibles nearby the motor, amplifier and external regenerative resistor.</b>	The failure could result in electric shock, personal injury or fire.
	<b>Do not use the products in a place subject to excessive vibration or shock.</b>	The failure could result in electric shock, malfunction or damage.
	<b>Do not use cables soaked in water or oil.</b>	The failure could result in fire or malfunction.
	<b>Never connect the motor directly to the commercial power supply.</b>	Failure to observe this instruction could result in electrical shock, injury or fire.
	<b>Do not attempt to carry out wiring or manual operation with wet hand.</b>	Failure to observe this instruction could result in burn and electrical shocks.
	<b>Do not put your hands in the amplifier.</b>	

	<b>Do not attempt to touch the keyway with bare hands when it is provided on a shaft end of a motor or gear head.</b>	Failure to observe this instruction could result in personal injury.
	<b>Do not touch the rotating portion of the motor while it is running.</b>	Failure to observe this instruction could result in burns.
	<b>Do not touch the motor, heat sink of amplifier and external regenerative resistor since they become very hot.</b>	Failure to observe this instruction could result in fire.
	<b>Do not drive the brushless motor with external power.</b>	Failure to observe this instruction could result in electrical shocks, damages and breakdowns.
	<b>Do not subject the cables to excessive force, heavy object, or pinching force, nor damage the cables.</b>	The failure to heed this precaution will result in electric shock, fire, malfunction or damage.
	<b>Install the motor in a clean location where it will not be exposed to drops of water or oil.</b>	Installation on a flammable material may cause fire.
	<b>Mount the motor, amplifier and external regenerative resistor on incombustible material such as metal.</b>	Wiring work done by an inexperienced person will cause electric shock.
	<b>Wiring has to be carried out by the qualified and authorized specialist.</b>	Wrong wiring or short circuit will cause electric shock, personal injury, malfunction or damage.
	<b>Arrange the phase sequense of the motor and wiring of the CS sensor.</b>	Incorrect wiring or short circuit will result in electric shock, fire or malfunction.
	<b>Positively and securely connect cables and safely isolate the live parts with insulation.</b>	Floating ground circuit will cause electric shock.
	<b>Ground the earth terminal of the motor and amplifier without fail.</b>	Wrong installation will cause electric shock, personal injury, fire, malfunction or damage.
	<b>Install and mount the Product and machinery securely to prevent any possible fire or accidents incurred by earthquake.</b>	The failure to heed these instructions will result in electric shock, personal injury or fire.
	<b>Install an emergency stop circuit externally so that you can stop the operation and shut off the power immediately.</b>	The failure to heed this instruction will result in electric shock.
<b>Install an overcurrent protection, earth leakage breaker, over-temperature protection and emergency stop apparatus without fail.</b>		
<b>Check and confirm the safety of the operation after the earthquake.</b>		
<b>Transportation, wiring and checking must be performed with power source turned off and after making sure that there is no risk of electric shock.</b>		

# Safety Precautions

Please observe safety precautions fully.



## Caution



<b>Do not hold the motor cable or motor shaft during the transportation.</b>	Failure to observe this instruction could result in injuries.
<b>Be sure to perform transportation and installation without drops and falls.</b>	Failure to heed these requirements will result in personal injury or malfunction.
<b>Do not get on the product. Do not place heavy object on the product.</b>	Failure to observe this instruction could result in electrical shocks, injuries, breakdowns and damages.
<b>Do not use the equipment under direct sunshine.</b>	Failure to heed these instructions will cause personal injury or fire.
<b>Do not block the heat dissipating holes or put the foreign particles into them.</b>	Failure to observe this instruction could result in electrical shocks and fire.
<b>Do not give strong impact shock to the Product.</b>	Failure to observe this instruction could result in breakdowns.
<b>Do not give strong impact shock to the motor shaft.</b>	
<b>Never run or stop the motor with the electromagnetic contactor installed in the main power side.</b>	Failure to observe this instruction could result in injuries.
<b>Do not make an extreme gain adjustment or change of the drive. Do not keep the machine running/operating unstably.</b>	
<b>Do not approach to the machine since it may suddenly restart after the power resumption. Design the machine to secure the safety for the operator even at a sudden restart.</b>	The failure to heed this instruction will result in fire, electric shock, personal injury or malfunction.
<b>Never attempt to perform modification, dismantle or repair.</b>	
<b>Do not turn on and off the main power of the amplifier repeatedly.</b>	The failure to heed this instruction can cause malfunction.



<b>Make an appropriate mounting of the Product matching to its weight and output rating.</b>	The failure to heed this instruction can result in personal injury or malfunction.
<b>Observe the specified mounting method and direction.</b>	Temperature rise due to poor ventilation can cause burn injury or fire.
<b>Do not place any obstacle object which blocks air passage around the motor, amplifier and peripheral.</b>	
<b>Adjust the motor and amplifier ambient environmental condition to match the motor operating temperature and humidity.</b>	Failure to heed these requirements will result in personal injury or malfunction.
<b>Provide the specified space between the amplifier and inner surface of the control panel and other devices.</b>	
<b>Observe the specified voltage.</b>	Operation from a voltage higher than the rated voltage will cause electric shock, personal injury or fire.
<b>Install a safety device against idling or locking of gear head, and leakage of grease.</b>	Lack of protection will cause personal injury, property damage or pollution.
<b>Use the motor and the amplifier in the specified combination.</b>	Wrong combination will cause malfunction or fire during operation.
<b>Test-run the securely fixed motor without loading to verify normal operation, and then connect it to the mechanical system.</b>	Operation with wrong model or wrong wiring will cause bodily injury.
<b>If trip occurs, remove the causes of the trip and secure the safety before restarting.</b>	The failure to heed this instruction will cause bodily injury.
<b>When failure occurs at the amplifier, turn off power to the amplifier.</b>	Continuous high current flow will cause fire.
<b>Correctly run and arrange wiring.</b>	Wrong connection will cause injury or electric shock.
<b>Always keep power disconnected when the power is not necessary for a long time.</b>	The failure to heed this instruction will cause improper operation that could result in hazards to personnel.
<b>Maintenance must be performed by an experienced personnel.</b>	Wrong connection will cause injury or electric shock.

**This Product shall be treated as Industrial Waste when you dispose.**

# Introduction

## Product Overview

This motor is brushless type. Carefully read through this manual so that you will properly and safely operate it for a long term.

This motor is designed to be built into general-purpose industrial equipment. However, only properly trained and responsible individuals should operate this product.

### <Caution>

When exporting a product containing this motor, make sure that the product will meet the legal requirements of the destination country.

## After unpacking

- Make sure that the model is what you have ordered.
- Check whether the product has been damaged or not during transportation.

**If any deficiency should be found,  
contact the dealer store where you bought this product.**

# Product designation

## Checking the model of Motor, Amplifier and Gear head

This amplifier is designed for use in combination with a motor to be specified by us.

Check a name of series, rated output, voltage specifications you wish to use

**You must not use any other combinations than those listed below:**

**Failure to observe this instruction could result in breakdowns.**

### • GV series (Velocity control type)

Shaft type	Voltage (V)	Motor size (mm)	Out put (W)	Motor Type	Applicable Amplifier	Applicable Gear head*	Reduction ratio
Pinion shaft	Single phase AC100 to 120	<input type="checkbox"/> 80	50	MBMU5AZAX	MBEG5A1BCV	MX8G○B	3 to 180
		<input type="checkbox"/> 90	90	MBMU9A1AZ	MBEG9A1BCV	MZ9G○B MY9G○B	3 to 200
			130	MBMU1E1AZ	MBEG1E1BCV		
	Single phase/ 3-phase AC200 to 240	<input type="checkbox"/> 80	50	MBMU5AZAX	MBEG5A5BCV	MX8G○B	3 to 180
		<input type="checkbox"/> 90	90	MBMU9A2AZ	MBEG9A5BCV	MZ9G○B MY9G○B	3 to 200
			130	MBMU1E2AZ	MBEG1E5BCV		
Round shaft	Single phase AC100 to 120	<input type="checkbox"/> 80	50	MBMU5AZAS	MBEG5A1BCV	-	-
		<input type="checkbox"/> 90	90	MBMU9A1AS	MBEG9A1BCV		
			130	MBMU1E1AS	MBEG1E1BCV		
	Single phase/ 3-phase AC200 to 240	<input type="checkbox"/> 80	50	MBMU5AZAS	MBEG5A5BCV		
		<input type="checkbox"/> 90	90	MBMU9A2AS	MBEG9A5BCV		
			130	MBMU1E2AS	MBEG1E5BCV		

\* A figure representing reduction ration in ○

e.g.) Part number of MX type gear head with reduction ratio 10 is MX8G10B.

• Brushless amplifier having the suffix V in the model designation is the GV series.

### • GP series (Position control type)

Shaft type	Voltage (V)	Motor size (mm)	Out put (W)	Motor Type	Applicable Amplifier	Applicable Gear head*	Reduction ratio
Pinion shaft	Single phase AC100 to 120	<input type="checkbox"/> 80	50	MBMU5AZAB	MBEG5A1BCP	MB8G○BV	5 to 50
		<input type="checkbox"/> 90	90	MBMU9A1AB	MBEG9A1BCP	MB9G○BV	
			130	MBMU1E1AB	MBEG1E1BCP	MB9G○BV	
	Single phase/ 3-phase AC200 to 240	<input type="checkbox"/> 80	50	MBMU5AZAB	MBEG5A5BCP	MB8G○BV	
		<input type="checkbox"/> 90	90	MBMU9A2AB	MBEG9A5BCP	MB9G○BV	
			130	MBMU1E2AB	MBEG1E5BCP	MB9G○BV	

\* A figure representing reduction ration in ○

e.g.) Part number of MB type gear head with reduction ratio 10 is MB8G10BV.

• Brushless amplifier having the suffix P in the model designation is the GP series.

# Product designation/ Name of each part

## Checking the model number of brushless motor

### Nameplate

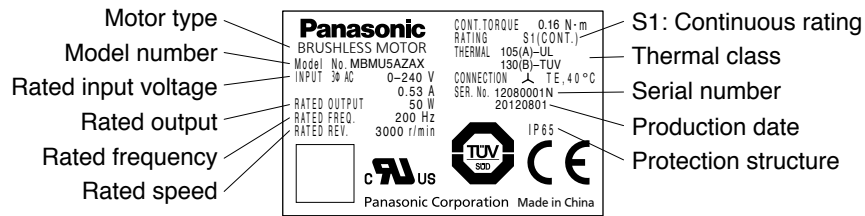

### Model designation

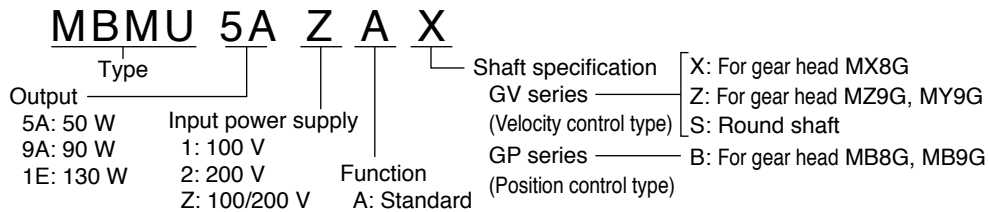

### Serial number

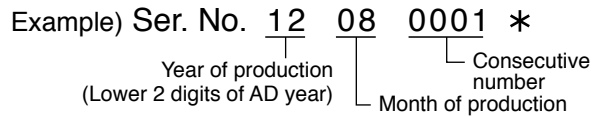

The motor manufactured in Aug. 2012 is given the Serial number 0001.

### Production date

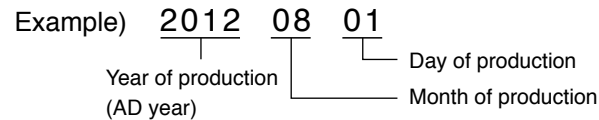

## Name of part

### Brushless motor

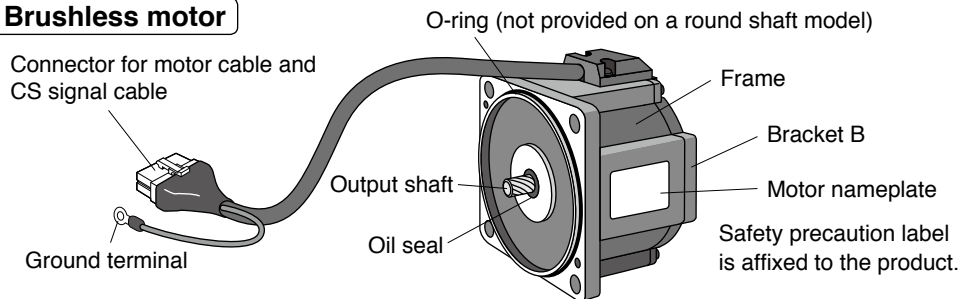

# Installation

This section describes the installation guidelines and the various considerations that must be taken into account when planning the installation.

## Transport

Use caution enough in transporting the unit to prevent injury by drop or fall, and avoid damage to the equipment.

## Storage

Keep the unit indoors in a clean and dry place free from vibration with little change of temperature.

## Location

Location gives great influence upon the life of brushless amplifier, therefore choose a place in conformance with the conditions below:

- (1) Indoors where the motor is not subjected to rain water and direct sun beam.
- (2) Do not use the motor in corrosive atmosphere such as hydrogen sulfide, sulfurous acid, chlorine, ammonia, sulfur, gas chloride, gas sulfide, acid, alkali, and salt, in the atmosphere of combustible gas, or in the vicinity of flammables.
- (3) Place not exposed to grinding liquid, oil mist, iron powder, and cutting particle.
- (4) Well-ventilated place with little moisture, oil, or inundation, and place far from heat source such as a furnace.
- (5) Place easy to check and clean
- (6) Place free from vibration
- (7) Do not use the unit in an enclosed environment. Enclosing may raise the temperature of motor (amplifier), and shorten their life.

## Caution in installing gear head

Install a device that will ensure safety operation of the system even if the following failures should occur on the life end of gear head: idling by damaged teeth, locking by bite, grease leakage, and the like.

- As for application such as on a lifter or the like device, install a device for preventing drop by damaged teeth.
- As for application such as opening and closing of door, install a release device against locking by gear biting.
- As for food or textile equipment, install an oil pan for measures against grease leakage.
- Do not install an encoder, sensor, contact, etc., in the proximity of gear head. Or otherwise, protect such devices against grease leakage.
- In order to prevent unexpected accident, be sure to perform daily check.

# Installation

## Environmental condition

Item	Condition
Ambient temperature	-10 °C to 40 °C (free from freezing) <sup>*1</sup>
Ambient humidity	20% to 85% RH (free from condensation)
Storage temperature	At normal temperature and normal humidity <sup>*2</sup>
Protection structure	IP65 (Excluding shaft pass-through section and lead wire connector) <sup>*3</sup>
Vibration	Not greater than 4.9 m/s <sup>2</sup> (10 to 60 Hz)
Altitude	Not greater than 1000 m

- \*1 Ambient temperature is measured at a distance of 5 cm from the motor.  
 \*2 Temperature which is acceptable for a short time, such as during transportation, is -20 °C to 60 °C (free from freezing).  
 \*3 This motor meets test requirements specified in EN standards (EN60529 and EN60034-5).  
 This motor cannot be used for an application that requires long term waterproof performance, such as the case where the motor is always washed with water.

## Installation of brushless motor

### Oil and water protection

- 1) Direct down the lead of cable as far as possible.
- 2) Avoid use in such an environment where the motor is always exposed to oil and water.
- 3) Avoid use with cable immersed in oil or water.

### Stress to cable

- 1) Make sure that stress is not applied to the lead or connection of cable due to bending or dead weight.
- 2) In installation where the motor moves, fix the cable of motor, and house the extension cable connected to it in the cable bear to reduce stress by bending as small as possible.
- 3) Allow the bending radius of cable as large as possible.

### Output shaft permissible load

- 1) The mechanical system should be so designed that the permissible radial load and thrust load specified for a specific model will be supported by the shaft during installation and operation.
- 2) When using rigid coupling, avoid application of unnecessary load. Excessive bending load will cause breaking of shaft or shortening of bearing life.
- 3) Use a high rigid but flexible coupling so that the radial load due to minute misalignment is limited below the allowable value.

### Installation guidelines

- 1) When installing a coupling to or removing a coupling from the motor shaft end, do not apply shock directly to the shaft with e.g. a hammer.
- 2) Make an exact centering (incomplete alignment may cause vibration and damage the bearing).
- 3) Do not allow operation that will cause the frame surface temperature to rise to 80 °C or higher (ambient temperature at 40 °C).
  - Geared shaft motor should be used with the gear head attached to it.
  - Round shaft motor should be used with its heat dissipated to the machine and equipment.

# Wiring

## Wiring

### Standard wiring diagram

#### • In Case of 3-Phase 200 V

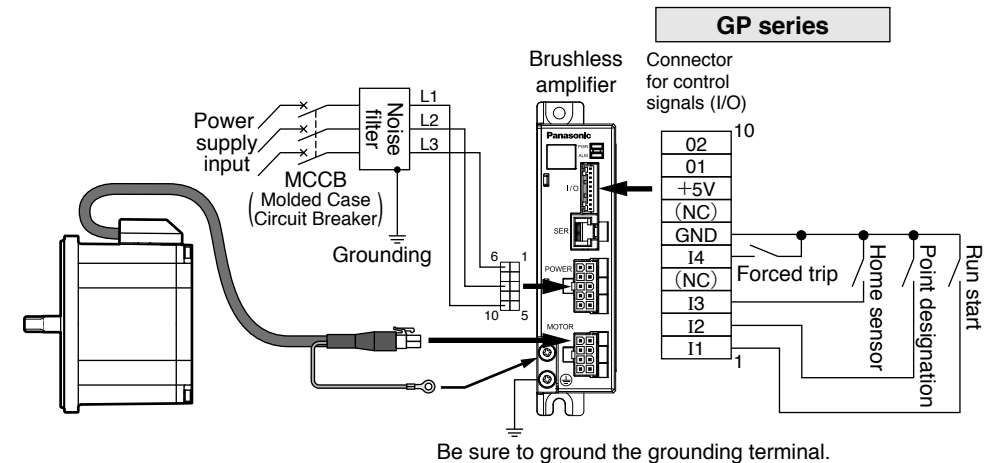
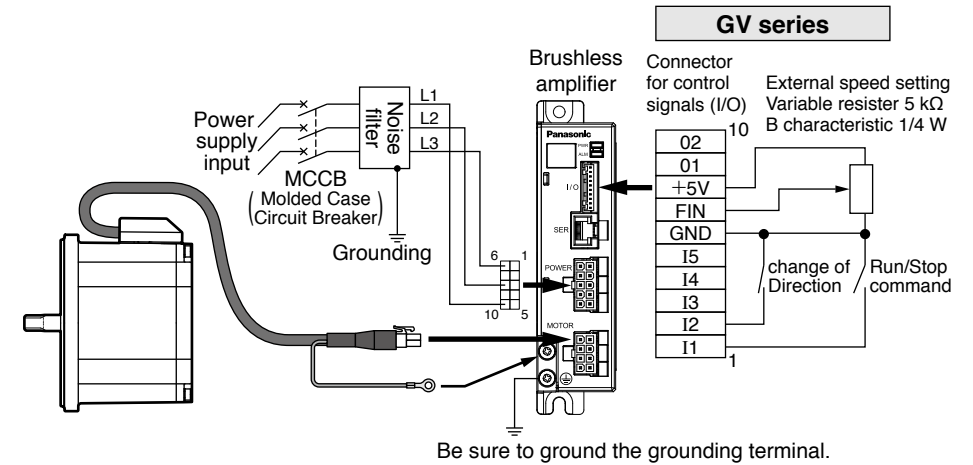

In wiring to power supply (outside of equipment) from MCCB, use an electric wire of 1.6 mm diameter (2.0 mm<sup>2</sup>) or more both for main circuit and grounding.  
 Apply grounding class D (100 Ω or below) for grounding.  
 Do not tighten the ground wires together, but connect them individually.  
 Fastening torque of earth screws to be 0.49 to 0.98 N·m.

# Wiring

• In case of single-phase 100 V/200 V

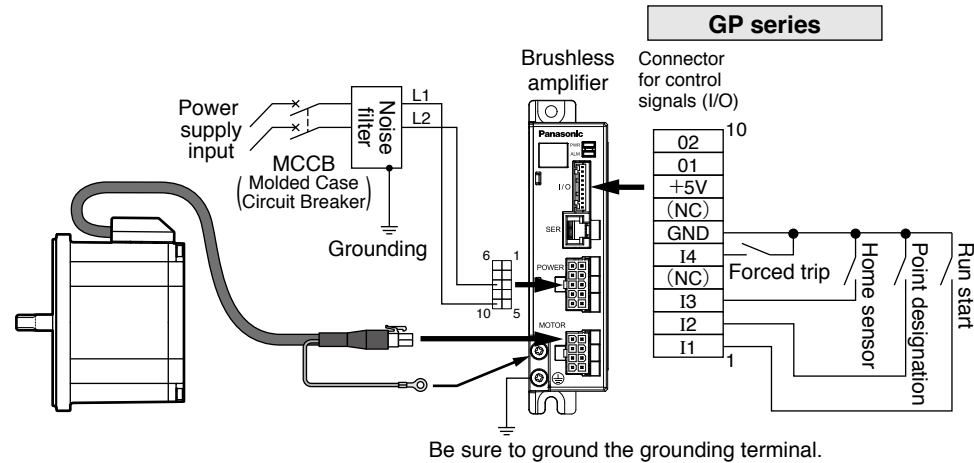
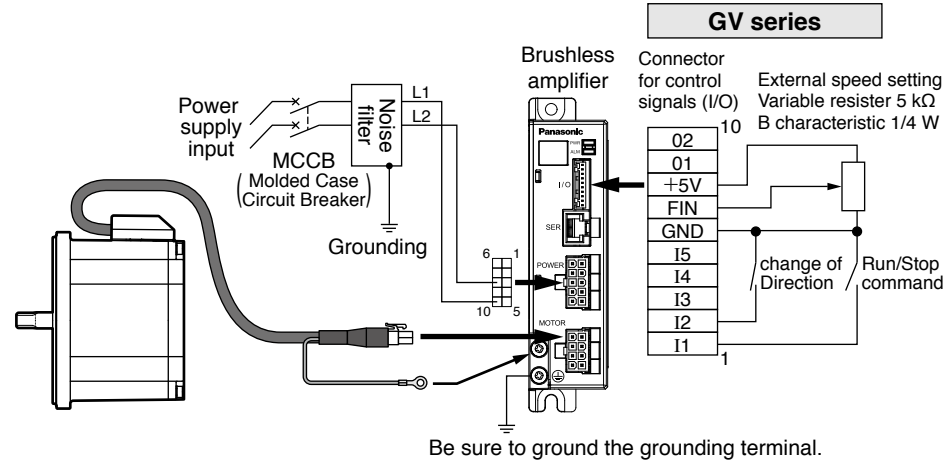

In wiring to power supply (outside of equipment) from MCCB, use an electric wire of 1.6 mm diameter (2.0 mm<sup>2</sup>) or more both for main circuit and grounding.  
 Apply grounding class D (100 Ω or below) for grounding.  
 Do not tighten the ground wires together, but connect them individually.  
 Fastening torque of earth screws to be 0.49 to 0.98 N·m.

# Maintenance/inspections

Routine maintenance and inspection are essential for proper and satisfactory operation of the motor.

## Notes to maintenance/inspection personnel

- Power-on/off operations should be done by the operators themselves for ensuring safety in checking.
- Do not touch the motor while it is running or immediately after it stops because it gets hot and stays hot for a while after power has been turned off.
- When testing the insulation resistance of the brushless amplifier with the megger, disconnect the amplifier from all associated devices. Performing megger testing without first disconnecting these devices will cause failure.

## Maintenance/ Inspection item

Maintenance/ Check item	Inspection procedure	Condition
Input voltage	Voltmeter	Must be within ±10% of rating.
Input current	Ammeter	Must be within rated input current described on nameplate.
Insulation resistance	Insulation resistance tester	The resistance of motor should be 1 MΩ or higher when tested with a 500 V megger. Brushless motor: Across phase (U, V, W) and ground terminals
Noise	Hearing	Noise level must not be different from the usual level. In addition, abnormal noise such as rumbling noise must not be heard.
Vibration	By hand	Free from abnormal vibration.
Grease leakage	Visual check	Check that circumference of the motor and gear head are free from oil and grease. If grease leakage will cause problem, use grease sealing cover.
Installation bolt	Torque wrench	Check for loosening of bolt, and tighten additionally as necessary.
Use environment	By sight	Check the ambient temperature and humidity, and make sure that dirt, dust, or foreign substance is not found.

**When disassembly, troubleshooting, etc., is needed, be sure to contact our service department or the sales agent of purchase.**

# Conformance to EC directive and UL standard

## EC Directives

The EC directives apply to all such electronic products as those having specific functions and directly sold to general consumers in EU countries. These products are required to meet the EU unified standards and to be furnished with CE marking.

Our brushless motor and amplifier meet the EC Directives for Low Voltage Equipment so that the machine or equipment comprising our brushless motor and amplifier can meet relevant EC Directives.

## EMC Directives

Our brushless motor can meet EMC Directives and related standards. However, to meet these requirements, the systems must be limited with respect to configuration and other aspects, e.g. the installation and some special wiring conditions must be met. This means that in some cases machines and equipment comprising our brushless systems may not satisfy the requirements for wiring and grounding conditions specified by the EMC Directives. Therefore, conformance to the EMC Directives (especially the requirements for emission noise and noise terminal voltage) should be examined based on the final products that include our system.

## Applicable standard

	Applicable standard	
<b>UL</b>	UL1004	Standard for electric motor
<b>CSA (c-UL)</b>	C22.2 No.100	Standard for electric motor
<b>CE</b>	EN60034-1 EN60034-5	Standard for rotary electric machine (low voltage directive) Standard for rotary electric machine (low voltage directive)
<b>CCC</b>	GB12350	Safety standard for low-power electric motor

## Configuration of peripheral equipment

<b>Power supply</b>	<ul style="list-style-type: none"> <li>100 V system: Single phase 100 V to 120 V <math>\pm</math> 10%, 50/60 Hz</li> <li>200 V system: Single phase 200 V to 240 V <math>\pm</math> 10%, 50/60 Hz</li> <li>Use the equipment under the environment of overvoltage category II specified by IEC60664-1.</li> <li>In order to obtain overvoltage category III, insert a transformer conforming to EN standard or IEC standard to the input of brushless amplifier.</li> <li>Use an electric wire size suitable to EN60204-1.</li> </ul>
<b>Circuit breaker Fuse</b>	Be sure to connect a specified no-fuse breaker certified by IEC standard or UL, or a fuse certified by UL between power supply and noise filter. Meeting this condition allows conformance with UL508C (file No. E164620) and UL1004 (file No. E166557).
<b>Noise filter</b>	When installing one noise filter at the power supply for more than one brushless motor used, contact the manufacturer of noise filter.
<b>Surge absorber</b>	Install a surge absorber on the primary side of noise filter. However, in performing the voltage resistance test of machine and equipment, be sure to remove the surge absorber; otherwise, the surge absorber may be ruptured.
<b>Grounding</b>	Be sure to connect the grounding Terminal of brushless amplifier and protective grounding wire (PE) of system for preventing electric shock. Do not tighten the grounding wires together but connect them individually.

# Conformance to EC directive and UL standard/ Specifications

## Wiring of peripheral equipment

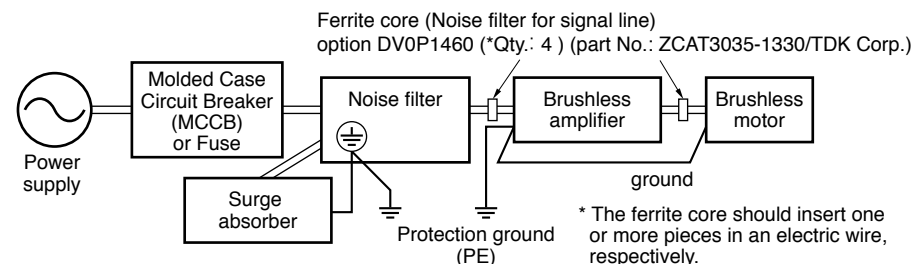

## Specifications

### • General specification

Model name		Rated output (W)	Power input			Motor Rated Current (A)	Rated torque (N·m)	Starting torque (N·m)	Rated rotation speed (r/min)	
Brushless * motor	Brushless * amplifier		Voltage (V)	Tolerance (%)	Frequency (Hz)					Rated input current (A)
MBMU5AZA *	MBEG5A1BC *	50	Single phase 100 to 120	$\pm$ 10	50/60	1.5	0.16	0.24	3000	
MBMU5AZA *	MBEG5A5BC *		Single/3-phase 200 to 240			0.7				
MBMU9A1A *	MBEG9A1BC *	90	Single phase 100 to 120			2.2	1.0	0.29		0.43
MBMU9A2A *	MBEG9A5BC *		Single/3-phase 200 to 240			1.1	0.5			
MBMU1E1A *	MBEG1E1BC *	130	Single phase 100 to 120			2.8	1.3	0.41		0.62
MBMU1E2A *	MBEG1E5BC *		Single/3-phase 200 to 240			1.5	0.72			

\* The "\*" in the motor designation is replaced with the symbol indicating the shaft specification.

\* The "\*" in the amplifier designation is replaced with the character V indicating GV series or P indicating GP series.

• **Never use a GP series amplifier in combination with a GV series motor. A wrong combination will cause malfunction.**

### • Common specification

Item	Specifications		
Brushless motor	<b>MBMU5AZA*</b>	<b>MBMU9A*A*</b>	<b>MBMU1E*A*</b>
Brushless amplifier	<b>MBEG5A*BC*</b>	<b>MBEG9A*BC*</b>	<b>MBEG1E*BC*</b>
Rated output (W)	50	90	130
Rated speed	3000 r/min		
Speed control range	30 to 4000 r/min (Speed ratio 1:133)		
Motor heat resistance class	130(B) (UL certified 105 (A))		
Time rating	Continuous		
Motor mass (kg)	(0.7)	(1.0)	(1.2)

# Specifications

## Outline dimensional drawing (Unit: mm)

### • Gear head

<MX8G□B>

(For GV series 50 W motor - sold separately)

- : Reduction ratio shown below:
- Reduction gear ratio is available in 22 types:  
3, 3.6, 5, 6, 7.5, 9, 10, 12.5, 15, 18, 20, 25  
30, 36, 50, 60, 75, 90, 100, 120, 150, 180

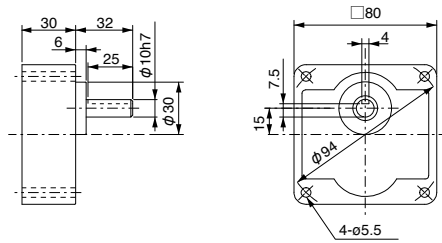

Outer size of key and key groove

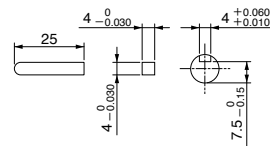

<MZ9G□B/MY9G□B>

(For GV series 90 W/130 W motor - sold separately)

- : Reduction ratio shown below:
- Reduction gear ratio is available in 23 types:  
3, 3.6, 5, 6, 7.5, 9, 10, 12.5, 15, 18, 20, 25  
30, 36, 50, 60, 75, 90, 100, 120, 150, 180, 200

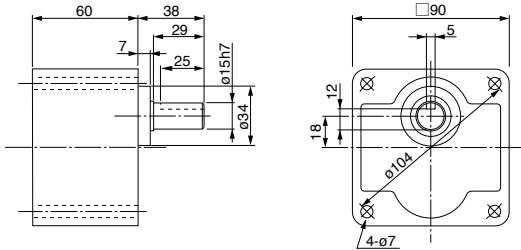

Outer size of key and key groove

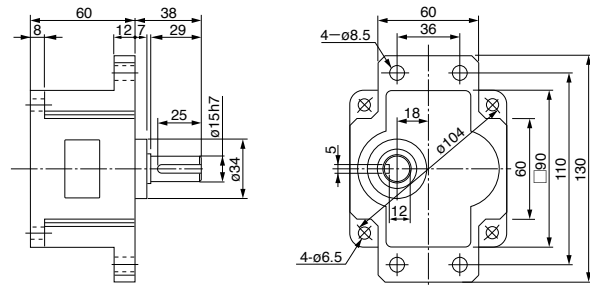
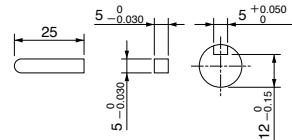

<MB8G□BV>

(For GP series 50 W motor - sold separately)

- : Reduction ratio shown below:
- Reduction gear ratio is available in 6 types:  
5, 10, 15, 20, 30, 50

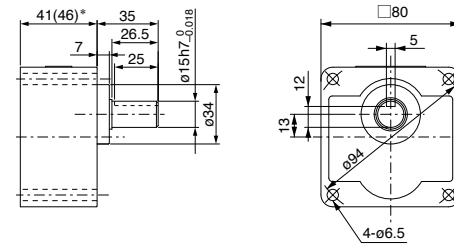

Outer size of key and key groove

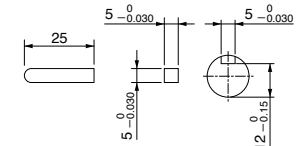

\* Dimensions of MB8G5BV - MB8G20BV:

Values in ( ) indicate dimensions of MB8G30BV - MB8G50BV.

<MB9G□BV>

(For GP series 90 W/130 W motor - sold separately)

- : Reduction ratio shown below:
- Reduction gear ratio is available in 6 types:  
5, 10, 15, 20, 30, 50

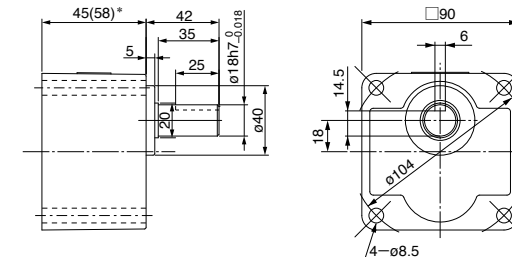

Outer size of key and key groove

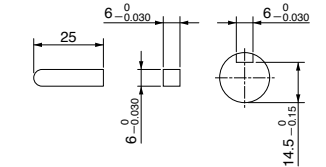

\* Dimensions of MB9G5BV - MB9G20BV:

Values in ( ) indicate dimensions of MB9G30BV - MB9G50BV.

### <Technical information>

Technical information on the products (installing method of gear head, allowable shaft torque, motor outline dimensional drawing, etc.) can be found on the catalog or downloaded from the web site of "Technical information" shown on the back cover.

## Cautions for Proper Use

### Cautions for Proper Use

- Practical considerations for exporting the product or assembly containing the product  
When the end user of the product or end use of the product is associated with military affair or weapon, its export may be controlled by the Foreign Exchange and Foreign Trade Control Law. Complete review of the product to be exported and export formalities should be practiced.
- Parts are subject to minor change to improve performance.
- This product is intended to be used with a general industrial product, but not designed or manufactured to be used in a machine or system that may cause personal death when it is failed.
- Install a safety equipments or apparatus in your application, when a serious accident or loss of property is expected due to the failure of this product.
- If you are planning to use this product under special environment, such as atomic power control, aerospace equipment, traffic organization, medical equipment, various safety systems, and equipment which requires cleanliness, please contact us.
- We have been making the best effort to ensure the highest quality of the products, however, application of exceptionally larger external noise disturbance and static electricity, or failure in input power, wiring and components may result in unexpected action. It is highly recommended that you make a fail-safe design and secure the safety in the operative range.
- When this product is operated without the shaft electrically grounded, such as in driving the fan, bearing noise may become higher due to the occurrence of electrocorrosion depending on the motor used or setting environment, so confirm and verify the condition on the customer side in such a case.
- Failure of this product depending on its content, may generate smoke of about one cigarette. Take this into consideration when the application of the machine is clean room related.
- Please be careful when using in an environment with high concentrations of sulphur or sulphuric gases, as sulphuration can lead to disconnection from the chip resistor or a poor contact connection.
- Take care to avoid inputting a supply voltage which significantly exceeds the rated range to the power supply of this product. Failure to heed this caution may result in damage to the internal parts, causing smoking and/or a fire and other trouble.

# After-Sale Service (Repair)

---

## Repair

Consult to a dealer from whom you have purchased the product for details of repair. When the product is incorporated to the machine or equipment you have purchased, consult to the manufacturer or the dealer of the machine or equipment.

## Technical information

Technical information of this product (Instruction Manual, CAD data) can be downloaded from the following web site.

[http://industrial.panasonic.com/ww/i\\_e/25000/motor\\_fa\\_e/motor\\_fa\\_e.html](http://industrial.panasonic.com/ww/i_e/25000/motor_fa_e/motor_fa_e.html)

### For your records:

The model number and serial number of this product can be found on either the back or the bottom of the unit. Please note them in the space provided and keep for future reference.

<b>Model No.</b>	MBMU <input type="text"/> <input type="text"/> <input type="text"/> A <input type="text"/>	<b>Serial No.</b>	
<b>Date of purchase</b>			
<b>Dealer</b>	Name		
	Address		
	Phone	(      )	-

Motor Business Unit, Panasonic Corporation

7-1-1 Morofuku, Daito, Osaka, 574-0044, Japan Phone : +81-72-871-1212

© Panasonic Corporation 2012

IME33+B  
Z0412-2082