



# EVALUATING THE AD9266/AD9649/AD9629/AD9609 ANALOG-TO-DIGITAL CONVERTERS

## Preface

This QuickStart user guide describes the evaluation boards, [AD9266-80EBZ](#), [AD9649-80EBZ](#), [AD9629-80EBZ](#), and [AD9609-80EBZ](#) that are used to evaluate the following Analog Devices, Inc., products: [AD9266](#), [AD9649](#), [AD9629](#), and [AD9609](#). These evaluation boards provide the support circuitry required to operate these devices in their various modes and configurations. The application software used to interface with the devices is also described.

The [AD9266](#), [AD9649](#), [AD9629](#), and [AD9609](#) data sheets provide additional information and should be consulted when using the evaluation board. All documents and software tools are available at [www.analog.com/hsadcevalboard](http://www.analog.com/hsadcevalboard). For additional information or questions, send an email to [highspeed.converters@analog.com](mailto:highspeed.converters@analog.com).

Note that, though the 80 MSPS speed grade ADCs and boards are referred to in this document, this user guide is applicable to the other speed grades, as well.

The [AD9266/AD9649/AD9629/AD9609](#) share ADC core characteristics with the [AD9269](#) family of dual ADCs. Additional application information can be found in the [Evaluation Board User Guide for Dual ADCs of this family](#).

## Typical Measurement Setup

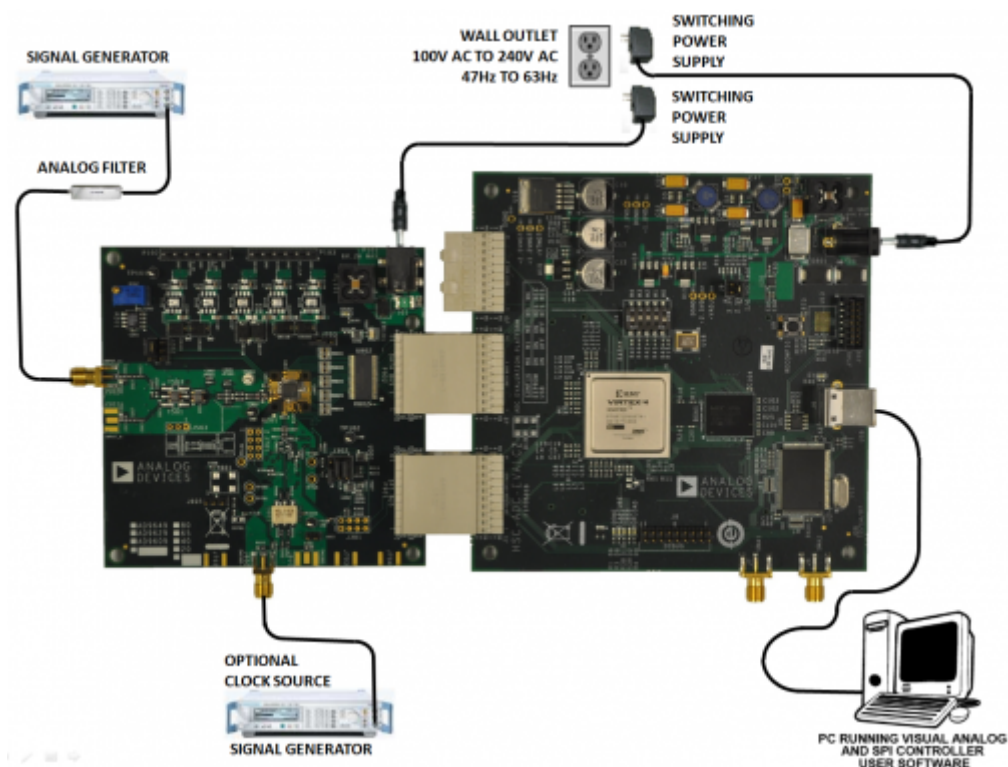

Figure 1. Evaluation Board Connection—[AD9266-80EBZ/AD9649-80EBZ/AD9629-80EBZ/AD9609-80EBZ](#) (on Left) and [HSC-ADC-EVALCZ](#) (on Right)

## Helpful Documents

- [AD9266, AD9649, AD9629, AD9609](#) data sheet
- [HSC-ADC-EVALC](#) data sheet
- [AN-905 Application Note, VisualAnalog Converter Evaluation Tool Version 1.0 User Manual](#)
- [AN-878 Application Note, High Speed ADC SPI Control Software](#)
- [AN-877 Application Note, Interfacing to High Speed ADCs via SPI](#)
- [AN-835 Application Note, Understanding ADC Testing and Evaluation](#)

## Design and Integration Files

- [Schematics, layout files, bill of materials](#)

## Equipment Needed

- Analog signal source and antialiasing filter
- Sample clock source (if not using the on-board oscillator)
- 2 switching power supplies (6.0 V, 2.5 A), CUI EPS060250UH-PHP-SZ (or equivalent), provided

- 
- PC running Windows®
  - USB 2.0 port
  - [AD9266-80EBZ](#), [AD9649-80EBZ](#), [AD9629-80EBZ](#), or [AD9609-80EBZ](#) board
  - [HSC-ADC-EVALCZ](#) FPGA-based data capture kit

## Getting Started

This section provides quick start procedures for using the [AD9266-80EBZ](#), [AD9649-80EBZ](#), [AD9629-80EBZ](#), or [AD9609-80EBZ](#) board.

## Configuring the Board

Before using the software for testing, configure the evaluation board as follows:

1. Connect the evaluation board to the data capture board, as shown in Figure 1. The [AD9266](#), [AD9649](#), [AD9629](#), and [AD9609](#) are all pin compatible and use the same evaluation board.
2. Connect one 6 V, 2.5 A switching power supply (such as the CUI, Inc., EPS060250UH-PHP-SZ (or equivalent) that is supplied) to the [AD9266-80EBZ/AD9649-80EBZ /AD9629-80EBZ /AD9609-80EBZ](#).
3. Connect one 6 V, 2.5 A switching power supply (such as the supplied CUI EPS060250UH-PHP-SZ (or equivalent)) to the [HSC-ADC-EVALCZ](#) board.
4. Connect the [HSC-ADC-EVALCZ](#) board (J6) to the PC using a USB cable.
5. On the ADC evaluation board, confirm that the jumpers are installed as shown in Figure 2. The configuration in Figure 2 enables SPI control of the device, with the onboard crystal oscillator enabled and utilizing the on-chip voltage reference.
6. On the ADC evaluation board, use a clean signal generator with low phase noise to provide an input signal to the Input SMA Connector J502. Use a shielded, RG-58, 50  $\Omega$  coaxial cable (optimally 1 m or shorter) to connect to the signal generator. For best results, use a narrow-band, band-pass filter with 50  $\Omega$  terminations and an appropriate center frequency. (Analog Devices uses TTE, Allen Avionics, and K&L band-pass filters.)
7. The evaluation board has an 80 MHz Valpey Fisher oscillator (VFAC3HL-80MHZ) that is enabled by jumpering J605 Pin 1 to J605 Pin 2. However, if the user provides an external clock source, provide a clean, low jitter clock source to Connector J602 at the desired ADC conversion rate. Move the jumper on J605 to connect Pin 2 to Pin 3 to override the built-in oscillator, and remove C610 to disconnect the oscillator from the external clock source. The input clock level should be between 10 dBm and 14 dBm.

## Evaluation Board Hardware

The evaluation board provides the support circuitry required to operate the [AD9266](#) and [AD9649](#) in their various modes and configurations. Figure 1 shows the typical bench characterization setup used to evaluate ac performance. It is critical that the signal sources used for the analog input and clock have very low phase noise (ideally  $\sim 100$  fs rms jitter) to realize the optimum performance of the

signal chain. Proper filtering of the analog input signal to remove harmonics and lower the integrated or broadband noise at the input is necessary to achieve the specified noise performance.

See [Schematics](#), [layout files](#), [bill of materials](#) for schematics and layout diagrams.

## Power Supplies

This evaluation board comes with a wall-mountable switching power supply that provides a 6 V, 2 A maximum output. Connect the supply to a 100 V ac to 240 V ac, 47 Hz to 63 Hz wall outlet. The output from the supply is provided through a 2.1 mm inner diameter jack that connects to the printed circuit board (PCB) at P101. The 6 V supply is fused and conditioned on the PCB before connecting to the low dropout linear regulators that supply the proper bias to each of the various sections on the board.

The evaluation board can be powered in a nondefault condition using external bench power supplies. To do this, remove E101, E102, E103, E105, E107, E108, and E114 ferrite beads to disconnect the bench supply traces from the on-board LDOs. Note that in some board configurations, some of these ferrite beads might already be uninstalled.

P102 and P103 need to be installed to connect external bench supplies to the board and E109, E110, E111, E112, and E113 need to be populated to connect P102 and P103 to the board power domains. A 1.8 V, 0.5 A supply is needed for P102 Pin 5 (1.8V\_DUT\_AVDD). The supplies for P103 Pin 1 (DUT\_DRVDD) and P103 Pin3 (AUX\_DVDD) can be any voltage from 1.8 V to 3.3 V. These two supplies can be shared or separate but if they are separate, the voltages on each must match the other.

Two additional supplies, 3.3V\_CLK and 3.3V\_AMPVDD, are used to bias the optional input path amplifiers, SPI buffers, and optional [AD9517-4](#) clock chip. If used, each of these supplies need at least a 0.5 A current capability.

## Input Signals

When connecting the ADC clock and analog source, use clean signal generators with low phase noise, such as the Rohde & Schwarz SMA, or an equivalent. Use a shielded, RG-58, 50  $\Omega$  coaxial cable (optimally 1 m or shorter) for connecting to the evaluation board. Enter the desired frequency and amplitude (see the Specifications section in the ADC data sheet). When connecting the analog input source, use of a multipole, narrow-band band-pass filter with 50  $\Omega$  terminations is recommended. Analog Devices uses band-pass filters from TTE and K&L Microwave, Inc. Connect the filters directly to the evaluation board.

When an external clock source is used, it must be supplied with a clean signal generator, as previously specified for the analog input signals. Analog Devices evaluation boards typically accept  $\sim 2.8$  V p-p or 13 dBm sine wave input for the clock. If an external off-board clock source is used, jumper J605 Pin 2 to J605 Pin 3 to disable the oscillator and remove C610 to disconnect the on-board crystal oscillator.

## Output Signals

The default setup uses the Analog Devices high speed converter evaluation platform ([HSC-ADC-EVALCZ](#)) for data capture. The outputs from the ADC are routed to Connector P902. For more information on the data capture board and its optional settings, visit [www.analog.com/hsadcevalboard](http://www.analog.com/hsadcevalboard).

## Jumper Settings

Set the jumper settings/link options on the evaluation board for the required operating modes before powering on the board. The functions of the jumpers are described in Table 1. Figure 2 shows the default jumper settings.

**Table 1. Jumper Settings**

Jumper	Description
J203	In the default state, the MODE_OR pin is an output that indicates an overrange condition. Connecting Pin 1 to Pin 2 connects the MODE_OR pin to an on-board LED to give a visual indication of overrange. SPI writes to Register 0x08 and Register 0x2A can configure the MODE_OR pin to be an input that controls power-down and standby modes. In the case where MODE_OR is configured as an input, connecting Pin 2 to Pin 3 invokes the programmed pin function; see the product datasheet for more information.
J302	J302 sets the ADC for SPI communications with the <a href="#">HSC-ADC-EVALCZ</a> . Connect Pin 1 to Pin 2 for SDIO, Pin 4 to Pin 5 for SCLK, and Pin 8 to Pin 9 for CSB.
J605	This jumper enables or disables the on-board crystal oscillator. Jumper Pin 1 to Pin 2 to enable the crystal oscillator; Jumper Pin 2 to Pin 3 to disable the oscillator, in the case where an external off-board clock source is used.
J201 and J202	These jumpers select between internal $V_{REF}$ and external $V_{REF}$ . To choose the internal (on-chip) 1 V reference, connect J201 Pin 2 (DUT_SENSE) to J201 Pin 3 (GND). No jumpers are needed on J202 for the internal (on-chip) 1 V reference. To use the on-board <a href="#">AD822BRZ</a> 1 V reference, connect J201 Pin 2 (DUT_SENSE) to J201 Pin 1 (1.8V_DUT_AVDD), and connect J202 Pin 2 (DUT_VREF) to J202 Pin 3 (EXT_REF). To apply a reference voltage from an external off-board source, connect J201 Pin 2 (DUT_SENSE) to J201 Pin 1 (1.8V_DUT_AVDD) and apply the reference voltage to J202 Pin 2 (DUT_VREF). The reference voltage is specified at 1.0 V for the AD9266, AD9649, AD9629, and AD9609.

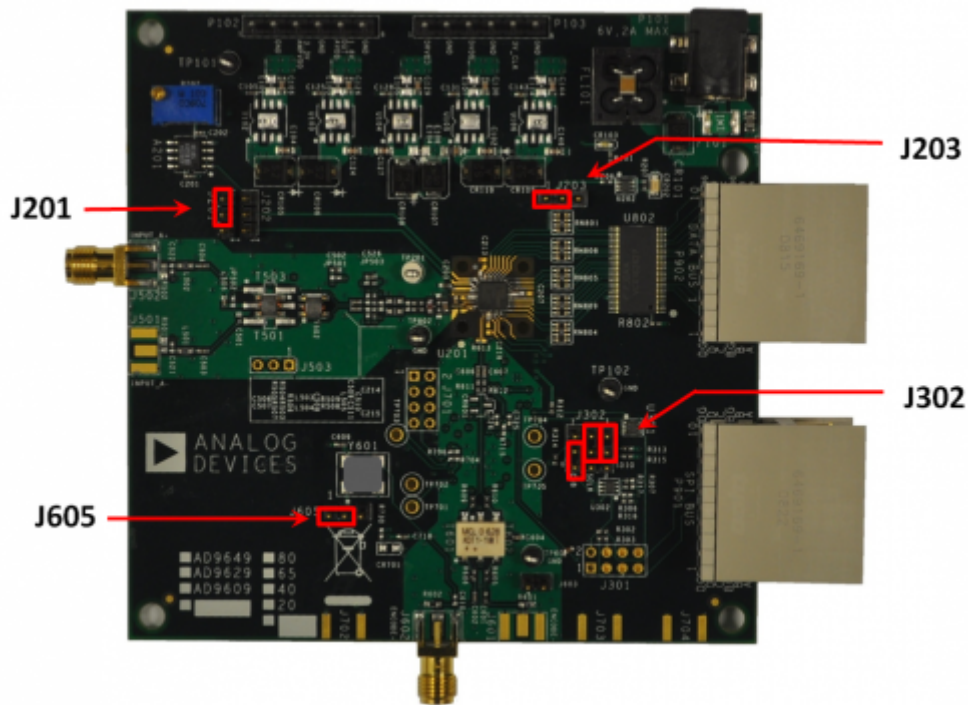

Figure 2. Default Jumper Connections for [AD9266-80EBZ](#)/[AD9649-80EBZ](#)/[AD9629-80EBZ](#)/[AD9609-80EBZ](#) Board

## Evaluation Board Circuitry

This section explains the default and optional ADC settings or modes allowed on the [AD9266-80EBZ](#) and the [AD9649-80EBZ](#) boards.

### Power

Connect the switching power supply that is supplied in the evaluation kit between a rated 100 V ac to 240 V ac, 47 Hz to 63 Hz wall outlet and to P101.

### Analog Input

The analog input on the evaluation board is set up for a double balun-coupled analog input with a 50  $\Omega$  impedance. The default analog input configuration supports analog input frequencies of up to ~200 MHz.

## RBIAS

DUT\_RBIAS has a default value of 10 k $\Omega$  (R203) to ground and is used to set the ADC core bias current. Note that using other than a 10 k $\Omega$ , 1% resistor for DUT\_RBIAS (R203) may degrade the performance of the device.

## Clock

The default clock input circuit is derived from a simple transformer coupled circuit using a high bandwidth 1:1 impedance ratio transformer (T601) that adds minimal jitter to the clock path. The clock input is 50  $\Omega$  terminated and ac-coupled to handle single-ended sinusoidal inputs. The transformer converts the single-ended input to a differential signal that is clipped by CR601 before entering the ADC clock inputs. The [AD9266](#), [AD9649](#), [AD9629](#), and [AD9609](#) ADCs are equipped with an internal 8:1 clock divider to facilitate use with higher frequency clocks. When using the internal divider and a higher input clock frequency, remove CR601 to preserve the slew rate of the clock signal.

The [AD9266-80EBZ](#), [AD9649-80EBZ](#), [AD9629-80EBZ](#), and [AD9609-80EBZ](#) boards are set up to be clocked through the transformer coupled input network from the crystal oscillator, Y601. If a different clock source is needed, remove C610 (optional) and place a jumper between Pin 2 and Pin 3 of J605 to disable the oscillator and connect the external clock source to the SMA connector, J602 (labeled ENCODE+).

## Modes of Operation

### Standalone (PIN) Mode

The [AD9266](#)/[AD9649](#)/[AD9629](#)/[AD9609](#) ADCs can operate in pin mode if there is no need to program and change the default modes of operation via the SPI. For applications that do not require SPI mode operation, the CSB pin is tied to 1.8V\_DUT\_AVDD by removing any jumper on Pin 8 of J302. In this configuration, the SDIO/PDWN pin controls the power-down function, and the SCLK/DFS pin controls the digital output format.

Table 2 and Table 3 specify the settings for pin mode operation. (These settings apply only when CSB is tied high, that is, J302 Pin 8 has no jumper.)



## Table 2. Power Down Pin Settings

SDIO/PDWN (J302 Pin 2) Voltage	Device Mode
AUX_DVDD (jumper J302 Pin 2 to Pin 3)	Power Down
GND (no jumper on J302 Pin 2)	Normal Operation

## Table 3. Digital Output Format Pin Settings

SCLK/DFS (J302 Pin 5) Voltage	Output Format
AUX_DVDD (jumper J302 Pin 5 to Pin 6)	Twos Complement
GND (no jumper on J302 Pin 5)	Offset Binary

Note that the settings in Table 2 and Table 3 apply only when CSB is tied high (J302 Pin 8 has no jumper) at power up.

Additional information on the standalone (pin) mode is provided in the [AD9266](#), [AD9649](#), [AD9629](#), and [AD9609](#) data sheets.

## Default Mode

To operate the device under test (DUT) using the SPI, follow the jumper settings for J302 as shown in Table 1.

# How To Use The Software For Testing

## Setting up the ADC Data Capture

After configuring the board, set up the ADC data capture using the following steps:

1. Open VisualAnalog on the connected PC (install from <http://www.analog.com/en/converters-tools/adc-tools/topic.html>). The appropriate device type is listed in the status bar of the **VisualAnalog - New Canvas** window. Select the template that corresponds to the type of testing to be performed (see Figure 3, where the [AD9266](#) is shown as an

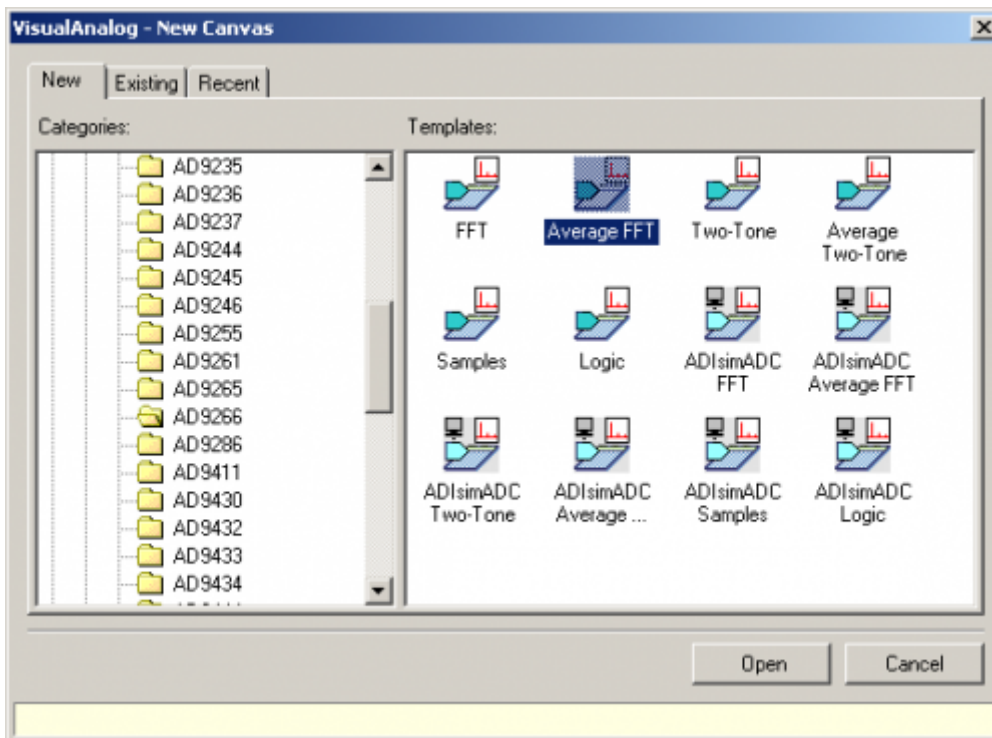
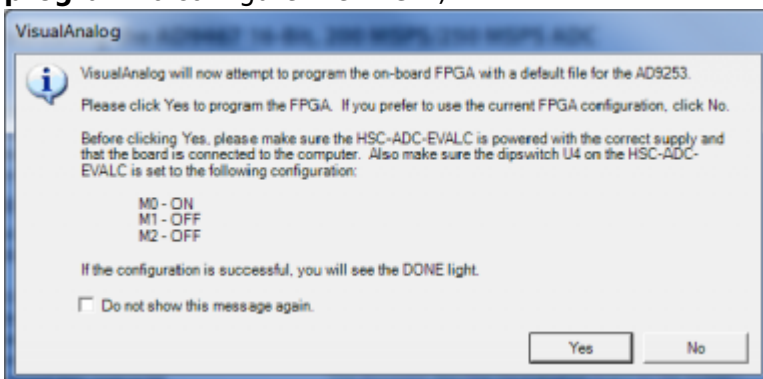

Figure 3.

example).

*VisualAnalog, New Canvas Window*

2. After the template is selected, a message might appear asking if the default configuration can be used to program the FPGA (see Figure 4). If this message appears, click **Yes**, and the window closes.
3. Select the template that corresponds to the type of testing that needs to be performed. **Average FFT** is a good first test to check ADC operation. Select **Yes** when VisualAnalog prompts for programming the FPGA.
4. The **Done** LED should illuminate on the HSC-ADC-EVALCZ board indicating that the FPGA is correctly programmed. (If VisualAnalog does not prompt for programming the FPGA, select the **ADC Data Capture Settings** window and click on the **Capture Board** tab. In the FPGA box select **program** to configure the FPGA.)



10235-005

Figure 4. VisualAnalog Default

*Configuration Message*

5. To change features to settings other than the default settings, click the **Expand Display** button, located on the right side of the window (see Figure 5), to display the window shown in Figure 6.
6. Change the features and capture settings by consulting the detailed instructions in the [AN-905 Application Note](#), *VisualAnalog Converter Evaluation Tool Version 1.0 User Manual*. After the changes are made to the settings within any of the control icons/blocks in the VA canvas, click the **OK** button to invoke the changes and collapse the edit window.

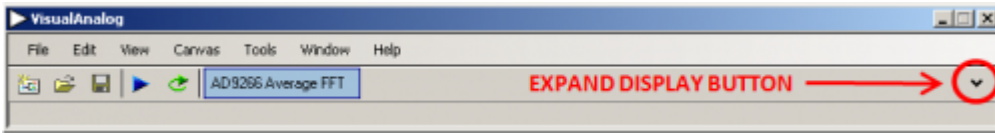

Figure 5. VisualAnalog Window Toolbar, Collapsed Display

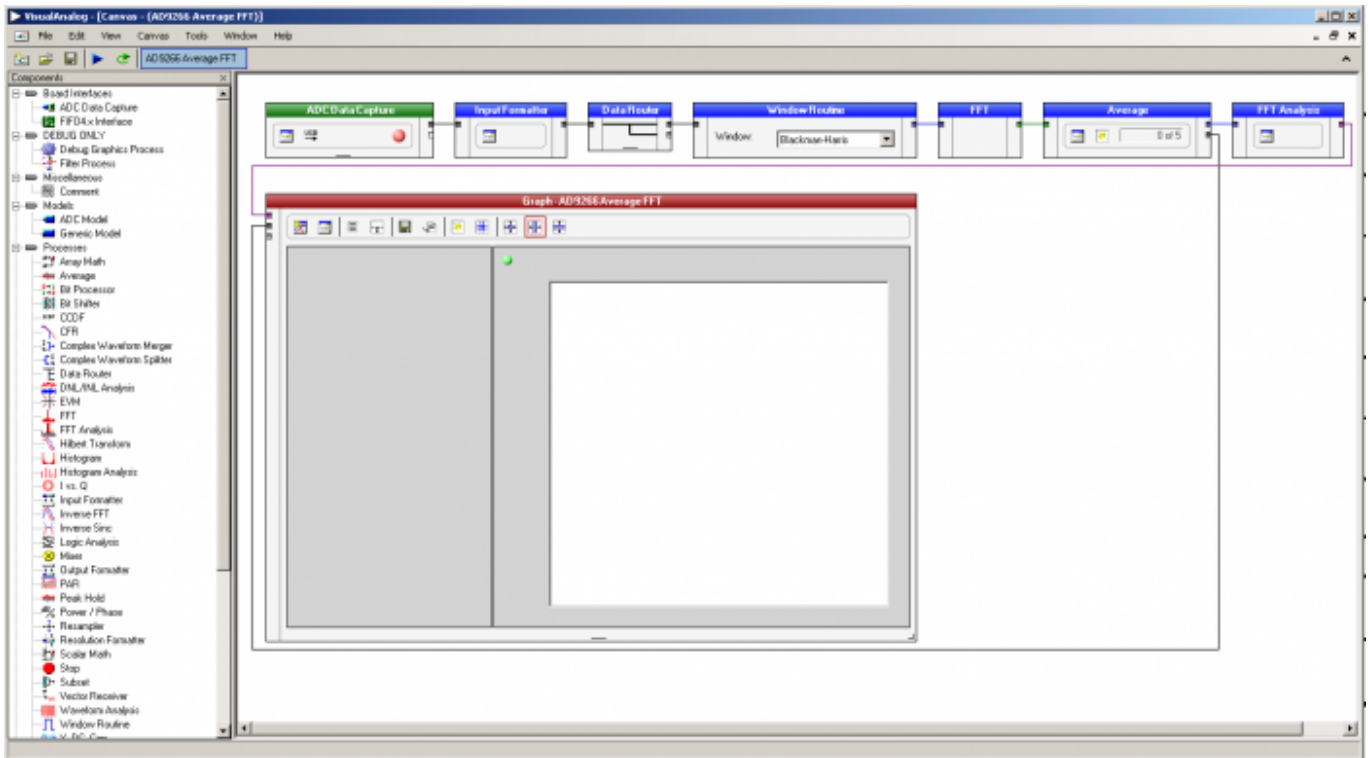

Figure 6. VisualAnalog, Main Window Expanded Display

## Evaluation And Test

### Setting up the SPI Controller Software

After the ADC data capture board setup is complete, set up the SPI controller software using the following procedure:

1. Open the SPI controller software by going to the **Start** menu or by double-clicking the **SPIController** software desktop icon. If prompted for a configuration file, select the appropriate one. If not, check the title bar of the window to determine which configuration is loaded. If necessary, choose **Cfg Open** from the **File** menu and select the appropriate file based on your part type. Note that the **CHIP ID(1)** box should be filled to indicate whether the correct SPI

controller configuration file is loaded (see Figure 7).

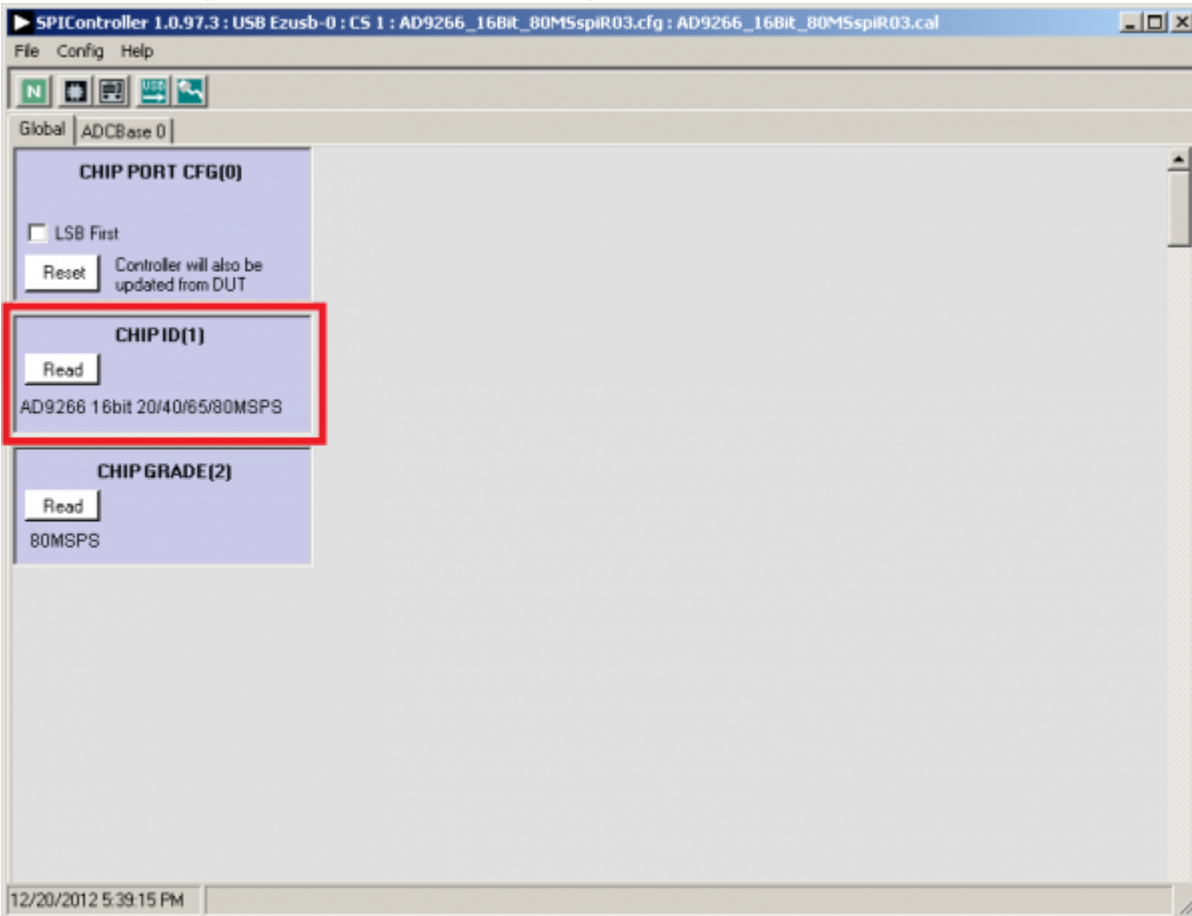

Figure 7.

*SPI Controller, CHIP ID(1) Box*

2. Click the **New DUT** button in the **SPIController** window (see Figure 8).

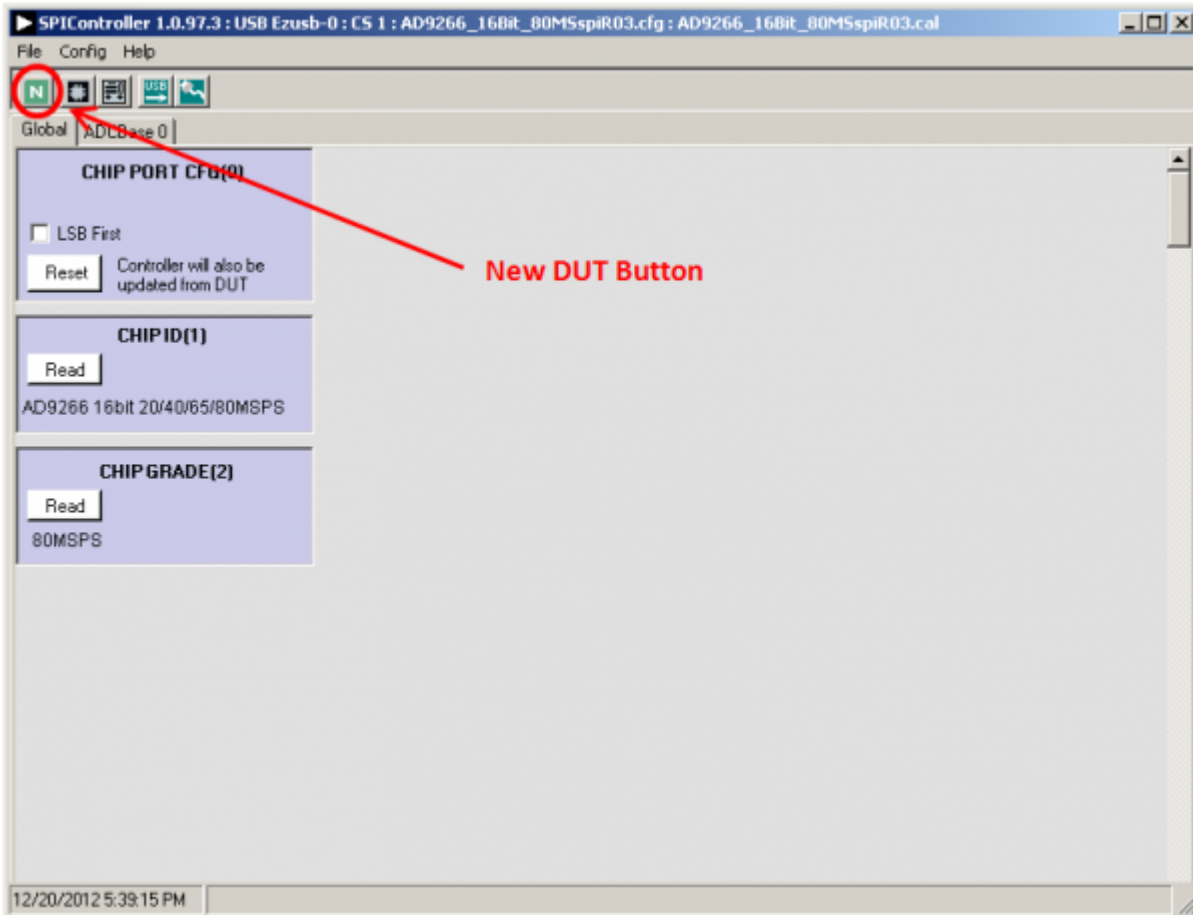

Figure 8.

*SPI Controller, New DUT Button*

3. In the **ADCBase 0** tab of the **SPIController** window, find the **CLOCK DIVIDE(B)** box (see Figure 9), and the **MODES(8)** box (see Figure 9). If using the clock divider, use the drop-down menu to select the correct clock divide ratio, as desired. If there is any interruption of the ADC clock during power-up or during operation, a digital reset may be needed to reinitialize the ADC (Figure 10). For additional information, refer to the data sheet, the [AN-878 Application Note, High Speed ADC SPI Control Software](#), and the [AN-877 Application Note, Interfacing to High Speed ADCs via SPI](#).

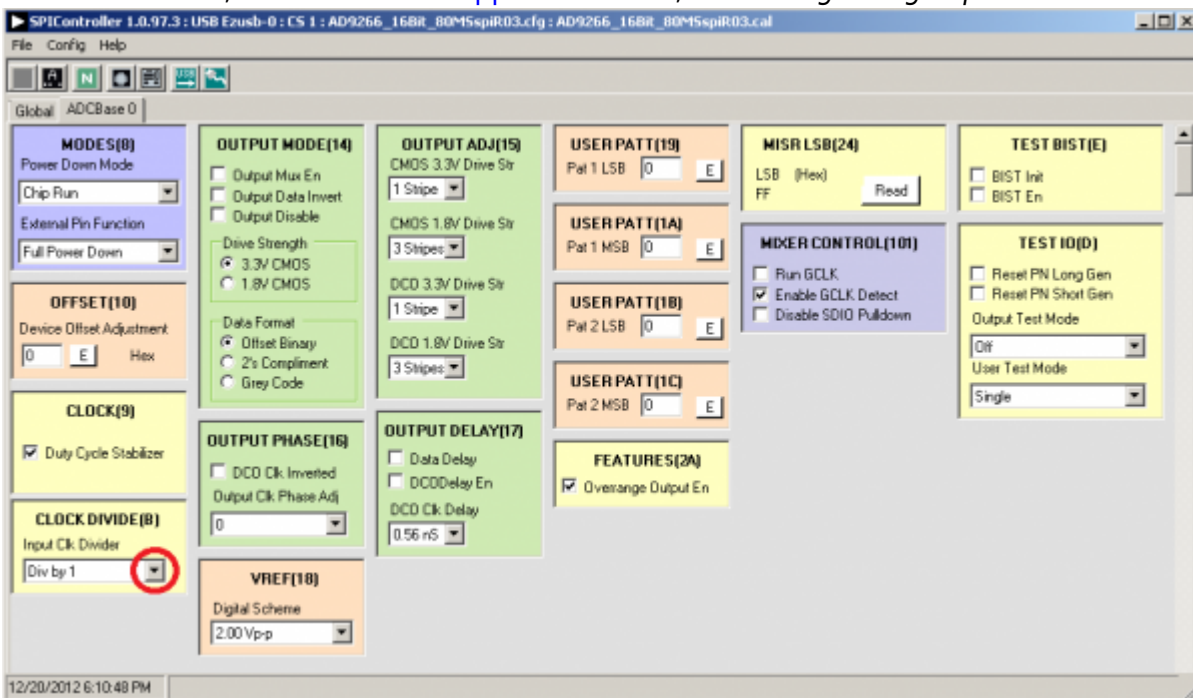

Figure 9.

*SPI Controller, CLOCK DIVIDE(B) Box*

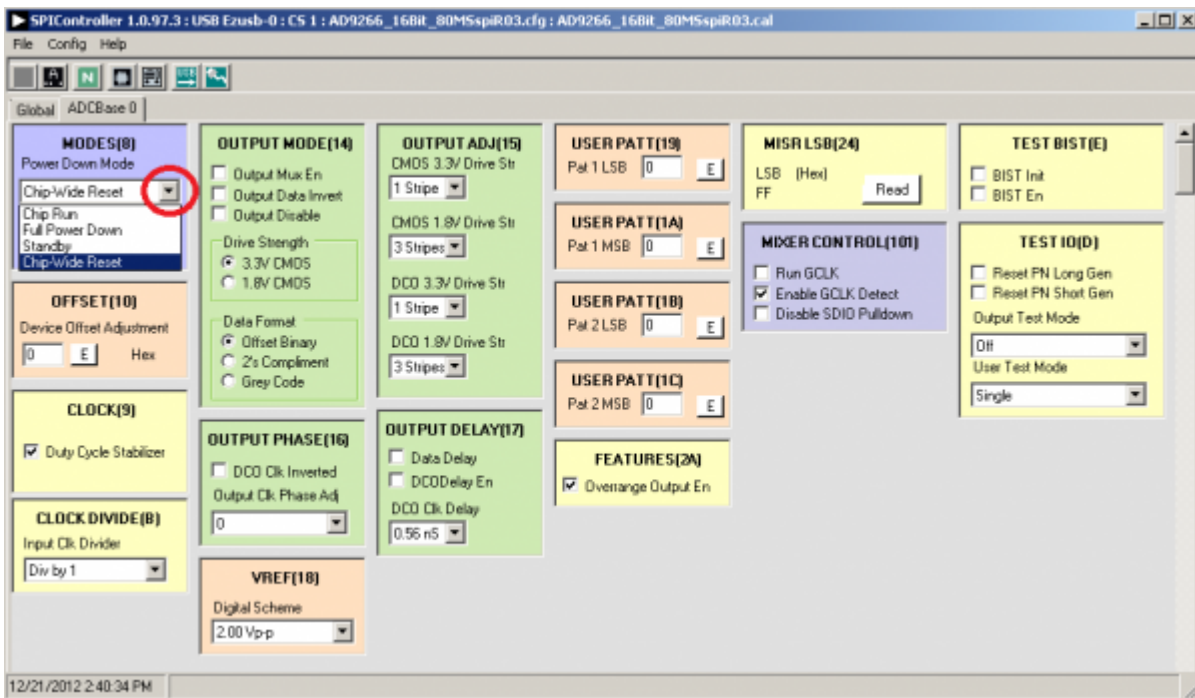

Figure 10. SPI Controller, Chip Power Mode - Digital Reset Selection

4. Note that other settings can be changed on the **ADCBASE 0** tab (see Figure 9) to set up the part in the desired mode. See the appropriate part data sheet, the [AN-878 Application Note, High Speed ADC SPI Control Software](#), and the [AN-877 Application Note, Interfacing to High Speed ADCs via SPI](#) for additional information on the available settings.
5. Click the **Run** or **Continuous Run** button in the **VisualAnalog** toolbar (see Figure 11).

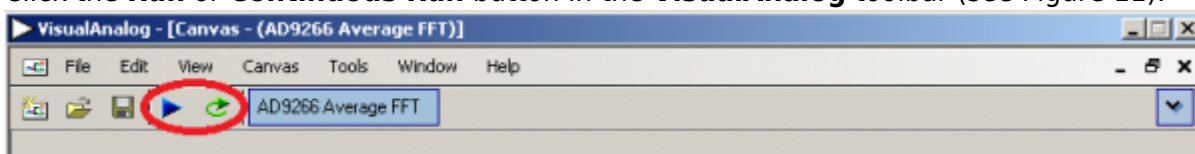
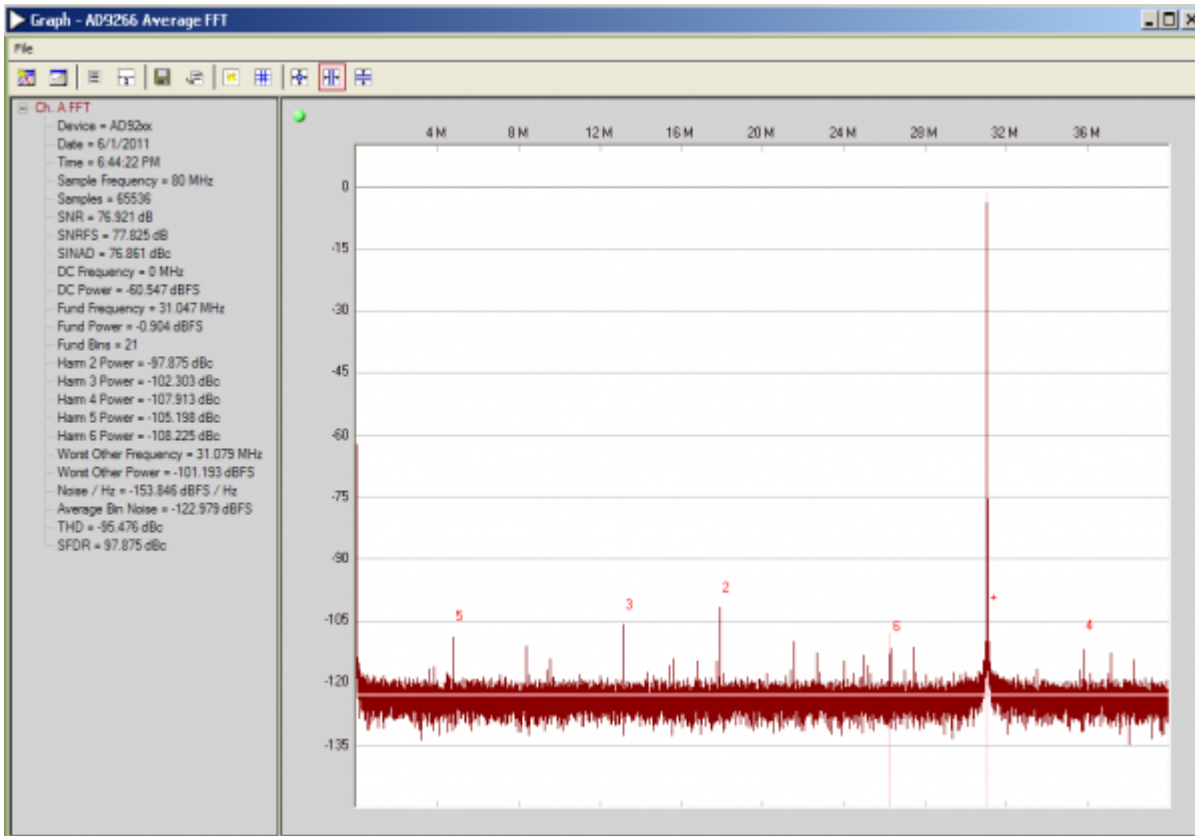

Figure 11. Run/Continuous Run Buttons (Encircled in Red) in VisualAnalog Toolbar, Collapsed Display

## Adjusting the Amplitude of the Input Signal

The next step is to adjust the amplitude of the input signal as follows:

1. Adjust the amplitude of the input signal so that the fundamental is at the desired level. Examine the **Fund Power** reading in the left panel of the **VisualAnalog Graph - AD9266 FFT** window (see Figure 12).



Figure

## 12. Graph Window of VisualAnalog

- Click the floppy disk icon within the **VisualAnalog Graph - AD9266 FFT** window to save the performance data as a .csv formatted file for plotting or analysis.

## Troubleshooting Tips

Lack of SPI communication causes difficulty in configuring the ADC.

- Go to the **Global** tab of the **SPIController** window and push the **Read** button in the **CHIP ID(1)** window. If “Unknown” appears in the CHIP ID field, the part might not be powered up, or SPI communication might not be working.
- Check that there is correct power to the [AD9266-80EBZ](#) or [AD9649-80EBZ](#) board and to the [HSC-ADC-EVALCZ](#).
- Check that the USB cable is properly connected from the PC to the [HSC-ADC-EVALCZ](#).
- The LED on the **VisualAnalog ADCDataCapture** block should be green. If it is red, push the USB button on the same block to refresh the connection.

If the FFT plot appears abnormal, do the following:

- If you see an abnormal noise floor, go to the **ADCBase0** tab of the **SPIController** window and toggle the **Chip Power Mode** in **MODES(8)** from **Chip Run** to **Reset** and back.
- If you see a normal noise floor when you disconnect the signal generator from the analog input, be sure that you are not overdriving the ADC. Reduce the input level, if necessary.
- In **VisualAnalog**, click the **Settings** icon in the **Input Formatter** block. Check that **Number Format** is set to the correct encoding (offset binary by default). Check that the **Number Format** in

the **VisualAnalog Input Formatter** matches the data format selected in the **SPIController ADCBase0 OUTPUT MODE(14)** window.

If the FFT appears normal but the performance is poor, check the following:

- That an appropriate filter is used on the analog input.
- That the signal generators for the clock and the analog input are clean (low phase noise).
- That if noncoherent sampling is being used, change the analog input frequency slightly.
- That the SPI configuration file matches the product being evaluated.

If the FFT window remains blank after **Run** in VisualAnalog (see Figure 12) is clicked, do the following:

- Make sure that the evaluation board is securely connected to the [HSC-ADC-EVALCZ](#) board.
- Make sure that the FPGA has been programmed by verifying that the **DONE** LED is illuminated on the [HSC-ADC-EVALCZ](#) board. If this LED is not illuminated, make sure that the U4 switch on the board is in the correct position for **USB CONFIG**.
- Make sure that the correct FPGA program was installed by clicking the **Settings** icon in the **ADC Data Capture** block in VisualAnalog. Then, select the **FPGA** tab and verify that the proper FPGA bin file is selected for the device.

© Analog Devices, Inc. All rights reserved. Trademarks and registered trademarks are the property of their respective owners.



[www.analog.com](http://www.analog.com)