



Joystick, 4 pos., stay-put.titan ring



Powering Business Worldwide™

Part no. M22-WRJ4
Article no. 279415

4 positions, use M22-A4 fixing adaptor

Delivery programme

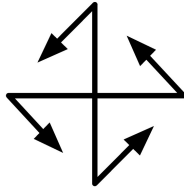
Product range			RMQ-Titan (drilling dimensions 22.5 mm)
Basic function			Joystick
Single unit/Complete unit			Single unit
Description			4 positions with one operating point per operating direction
Function			maintained in every position
Function			
Front ring			Front ring: titanium
Connection to SmartWire-DT			yes
Notes			
Bezel gold-plated →#274150			
Use adapter M22-A4→#216374			

Approvals

Product Standards	IEC/EN 60947-5; UL 508; CSA-C22.2 No. 14-05; CSA-C22.2 No. 94-91; CE marking
UL File No.	E29184
UL CCN	NKCR
CSA File No.	012528
CSA Class No.	3211-03
NA Certification	UL listed, CSA certified
Degree of Protection	UL/CSA Type 3R, 4X, 12, 13

General

Standards			IEC/EN 60947 VDE 0660
Lifespan, mechanical	Operations	x 10 ⁶	> 0.1
Operating frequency	Operations/ h		≅ 2000
Actuating force		n	≅ 5
Protection type			IP66
Climatic proofing			Damp heat, constant to IEC 60068-2-78 Damp heat, cyclic to IEC 60068-2-30
Ambient temperature		°C	
Open		°C	- 25 - + 70
Mounting position			As required
Mechanical shock resistance		g	30 Shock duration 11 ms Sinusoidal according to IEC 60068-2-27

Technical data ETIM 4.0

Coder			No
Color bezel			Chrome
Analog output signal configurable			No
Number of actuation directions			4
Number of N/Cs per actuation direction			0
Number of switch levels			1

Joy stick length		mm	75
Number of changeover contacts per direction			0
Rated operation current I _e at AC-21		A	0
Protection type (IP)			IP66
With bezel			YES
Central mounting, hole diameter		mm	22.5
Material front ring			Insulated material
Number of N/Os per actuation direction			0
Interlock in 0-position			No
With retraction in 0-position			No

Dimensions

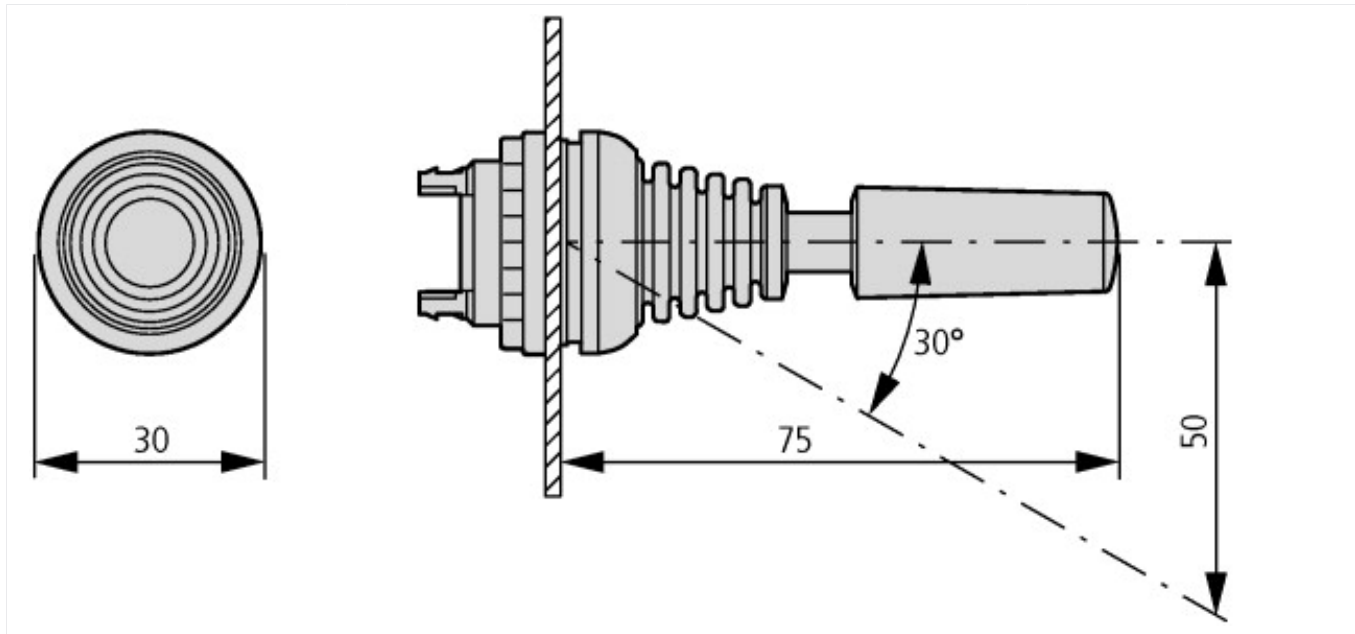

Additional product information (links)

IL04716002Z (AWA1160-1745) RMQ-Titan System

IL04716002Z (AWA1160-1745) RMQ-Titan System

ftp://ftp.moeller.net/DOCUMENTATION/AWA_INSTRUCTIONS/IL04716002Z2011_03.pdf