

Quad 2-line to 1-line selector/multiplexer, non-inverting (3-State)

74F257A

FEATURES

- Industrial range available (−40°C to +85°C)
- Multifunction capability
- Non-inverting data path
- 3-State outputs
- See 74F258A for inverting version

DESCRIPTION

The 74F257A has four identical 2-input multiplexers with 3-State outputs which select 4 bits of data from two sources under control of a common Select (S) input. The I0a inputs are selected when the common Select input is Low and the I1n inputs are selected when the common Select input is High. Data appears at the outputs in true non-inverted form from the selected inputs. The 74F257A is the logic implementation of a 4-pole, 2-position switch where the position of the switch is determined by the logic levels supplied to the common Select input. Outputs are forced to a high impedance “off” state when the Output Enable (\overline{OE}) is High. All but one device must be in high impedance state to avoid currents that would exceed the maximum rating if the outputs were tied together. Design of the Output Enable signals must ensure that there is no overlap when outputs of 3-state devices were tied together.

PIN CONFIGURATION

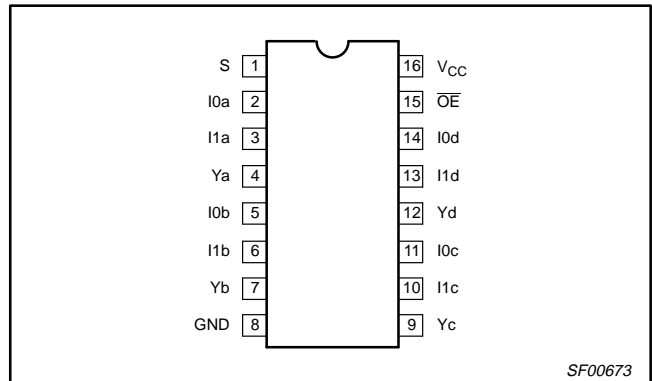

TYPE	TYPICAL PROPAGATION DELAY	TYPICAL SUPPLY CURRENT (TOTAL)
74F257A	4.3ns	12mA

ORDERING INFORMATION

DESCRIPTION	ORDER CODE		DRAWING NUMBER
	COMMERCIAL RANGE $V_{CC} = 5V \pm 10\%$, $T_{amb} = 0^{\circ}C$ to $+70^{\circ}C$	INDUSTRIAL RANGE $V_{CC} = 5V \pm 10\%$, $T_{amb} = -40^{\circ}C$ to $+85^{\circ}C$	
16-pin plastic DIP	N74F257AN	I74F257AN	SOT38-4
16-pin plastic SO	N74F257AD	I74F257AD	SOT109-1

INPUT AND OUTPUT LOADING AND FAN-OUT TABLE

PINS	DESCRIPTION	74F (U.L.) HIGH/LOW	LOAD VALUE HIGH/LOW
I0n, I1n	Data inputs	1.0/1.0	20 μ A/0.6mA
S	Common Select input	1.0/1.0	20 μ A/0.6mA
\overline{OE}	Output Enable input (active Low)	1.0/1.0	20 μ A/0.6mA
Ya – Yd	Data outputs	150/33	3.0mA/20mA

NOTE:

One (1.0) FAST unit load is defined as: 20 μ A in the High state and 0.6mA in the Low state.

LOGIC SYMBOL

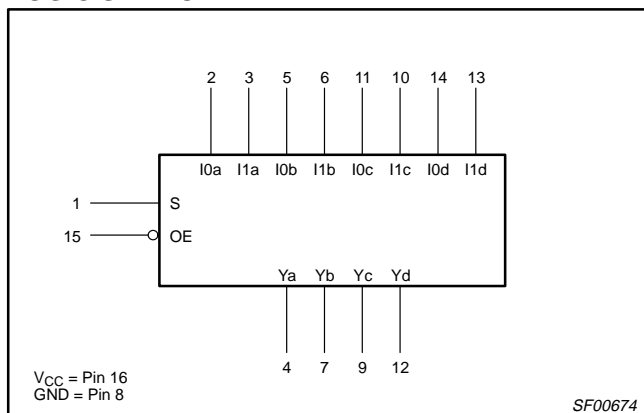

LOGIC SYMBOL (IEEE/IEC)

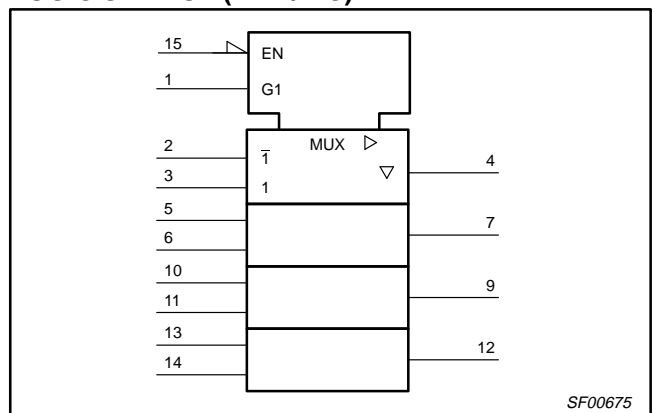

Quad 2-line to 1-line selector/multiplexer, non-inverting (3-State)

74F257A

LOGIC DIAGRAM

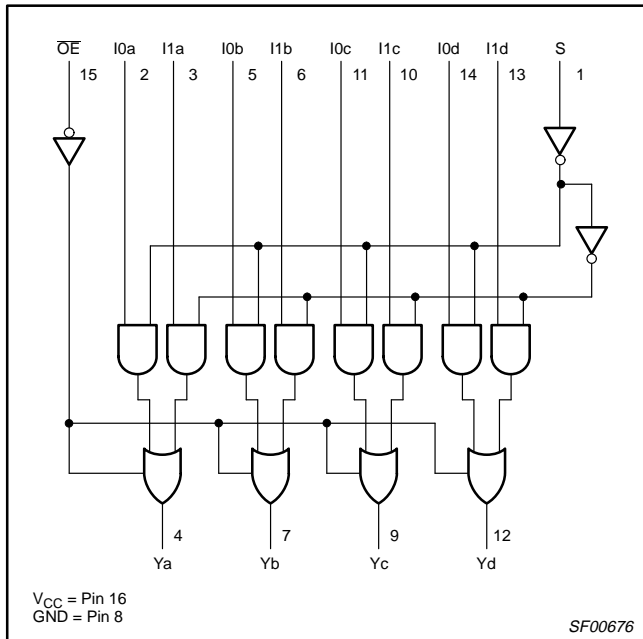

FUNCTION TABLE

INPUTS				OUTPUT
OE	S	I0	I1	Y
H	X	X	X	Z
L	H	X	L	L
L	H	X	H	H
L	L	L	X	L
L	L	H	X	H

H = High voltage level
 L = Low voltage level
 X = Don't care
 Z = High impedance "off" state

APPLICATION

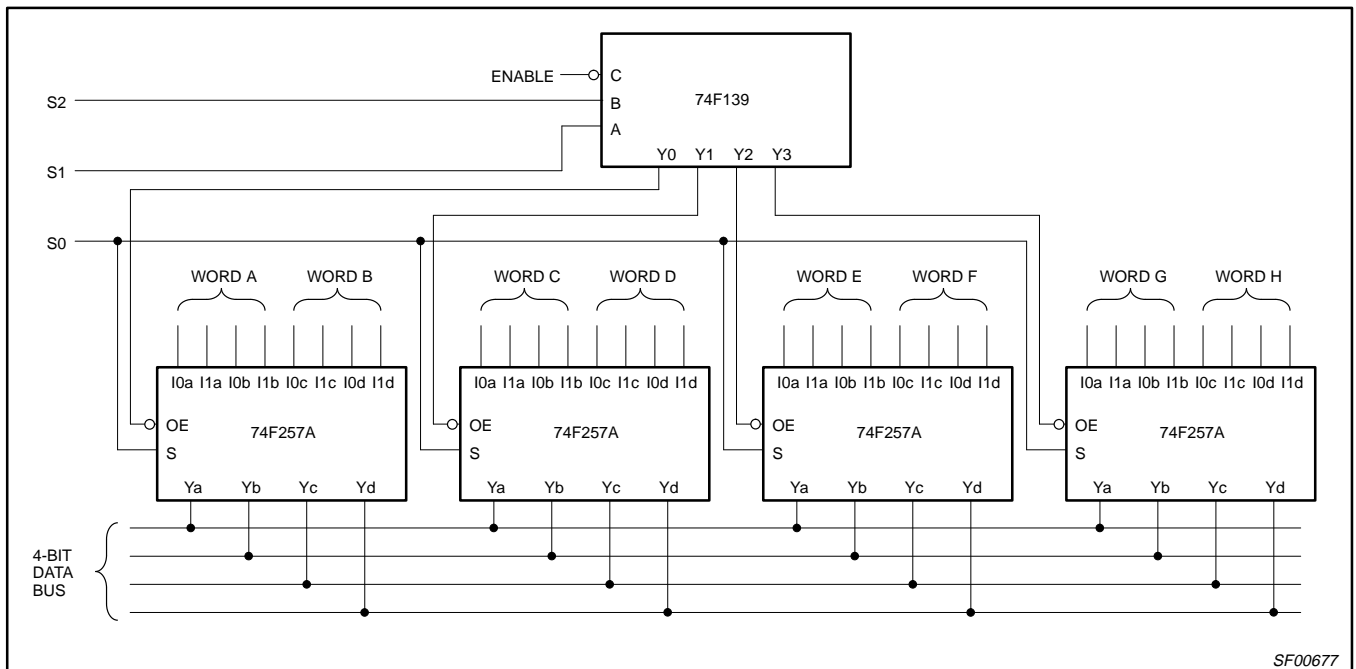

Quad 2-line to 1-line selector/multiplexer, non-inverting (3-State)

74F257A

ABSOLUTE MAXIMUM RATINGS

(Operation beyond the limits set forth in this table may impair the useful life of the device.
Unless otherwise noted these limits are over the operating free-air temperature range.)

SYMBOL	PARAMETER		RATING	UNIT
V _{CC}	Supply voltage		-0.5 to +7.0	V
V _{IN}	Input voltage		-0.5 to +7.0	V
I _{IN}	Input current		-30 to +5	mA
V _{OUT}	Voltage applied to output in High output state		-0.5 to V _{CC}	V
I _{OUT}	Current applied to output in Low output state		48	mA
T _{amb}	Operating free-air temperature range	Commercial range	0 to +70	°C
		Industrial range	-40 to +85	°C
T _{stg}	Storage temperature range		-65 to +150	°C

RECOMMENDED OPERATING CONDITIONS

SYMBOL	PARAMETER	LIMITS			UNIT
		MIN	NOM	MAX	
V _{CC}	Supply voltage	4.5	5.0	5.5	V
V _{IH}	High-level input voltage	2.0			V
V _{IL}	Low-level input voltage			0.8	V
I _{IK}	Input clamp current			-18	mA
I _{OH}	High-level output current			-3	mA
I _{OL}	Low-level output current			24	mA
T _{amb}	Operating free-air temperature range	Commercial range	0	+70	°C
		Industrial range	-40	+85	°C

Quad 2-line to 1-line selector/multiplexer, non-inverting (3-State)

74F257A

DC ELECTRICAL CHARACTERISTICS

(Over recommended operating free-air temperature range unless otherwise noted.)

SYMBOL	PARAMETER	TEST CONDITIONS ¹	LIMITS			UNIT	
			MIN	TYP ²	MAX		
V _{OH}	High-level output voltage	V _{CC} = MIN, V _{IL} = MAX, V _{IH} = MIN, I _{OH} = MAX	±10%V _{CC}	2.4		V	
			±5%V _{CC}	2.7	3.3	V	
V _{OL}	Low-level output voltage	V _{CC} = MIN, V _{IL} = MAX, V _{IH} = MIN, I _{OL} = MAX	±10%V _{CC}		0.35	0.50	V
			±5%V _{CC}		0.35	0.50	V
V _{IK}	Input clamp voltage	V _{CC} = MIN, I _I = I _{IK}		-0.73	-1.2	V	
I _I	Input current at maximum input voltage	V _{CC} = MAX, V _I = 7.0V			100	μA	
I _{IH}	High-level input current	V _{CC} = MAX, V _I = 2.7V			20	μA	
I _{IL}	Low-level input current	V _{CC} = MAX, V _I = 0.5V			-0.6	mA	
I _{OZH}	Off state output current, High-level voltage applied	V _{CC} = MAX, V _O = 2.7V			50	μA	
I _{OZL}	Off state output current, Low-level voltage applied	V _{CC} = MAX, V _O = 0.5V			-50	μA	
I _{OS}	Short-circuit output current ³	V _{CC} = MAX	-60		-150	mA	
I _{CC}	Supply current ⁴ (total)	V _{CC} = MAX	I _{CCH}		9.0	15.0	mA
			I _{CCL}		14.5	22.0	mA
			I _{CCZ}		15.0	23.0	mA

NOTES:

- For conditions shown as MIN or MAX, use the appropriate value specified under recommended operating conditions for the applicable type.
- All typical values are at V_{CC} = 5V, T_{amb} = 25°C.
- Not more than one output should be shorted at a time. For testing I_{OS}, the use of high-speed test apparatus and/or sample-and-hold techniques are preferable in order to minimize internal heating and more accurately reflect operational values. Otherwise, prolonged shorting of a High output may raise the chip temperature well above normal and thereby cause invalid readings in other parameter tests. In any sequence of parameter tests, I_{OS} tests should be performed last.
- Measure I_{CC} with all outputs open and inputs grounded.

AC ELECTRICAL CHARACTERISTICS

SYMBOL	PARAMETER	TEST CONDITION	LIMITS						UNIT	
			T _{amb} = +25°C V _{CC} = +5.0V C _L = 50pF R _L = 500Ω			T _{amb} = 0°C to +70°C V _{CC} = +5.0V ± 10% C _L = 50pF R _L = 500Ω		T _{amb} = -40°C to +85°C V _{CC} = +5.0V ± 10% C _L = 50pF R _L = 500Ω		
			MIN	TYP	MAX	MIN	MAX	MIN		MAX
t _{PLH} t _{PHL}	Propagation delay In to Yn	Waveform 1	3.0 2.0	4.5 3.5	6.0 5.0	3.0 2.0	7.0 6.0	3.0 2.0	7.0 7.0	ns
t _{PLH} t _{PHL}	Propagation delay S to Yn	Waveform 1	5.0 4.0	7.5 5.5	9.5 7.0	5.0 4.0	10.5 8.0	5.0 4.0	10.5 8.5	ns
t _{PZH} t _{PZL}	Output Enable time to High or Low level	Waveform 2 Waveform 3	4.5 4.5	6.5 6.0	7.5 7.5	4.5 4.5	8.5 8.5	4.5 4.5	8.5 8.5	ns
t _{PHZ} t _{PLZ}	Output Disable time from High or Low level	Waveform 2 Waveform 3	2.0 2.0	4.0 3.5	5.5 5.5	2.0 2.0	6.0 6.0	2.0 2.0	6.0 6.0	ns

Quad 2-line to 1-line selector/multiplexer, non-inverting (3-State)

74F257A

AC WAVEFORMS

For all waveforms, $V_M = 1.5V$.

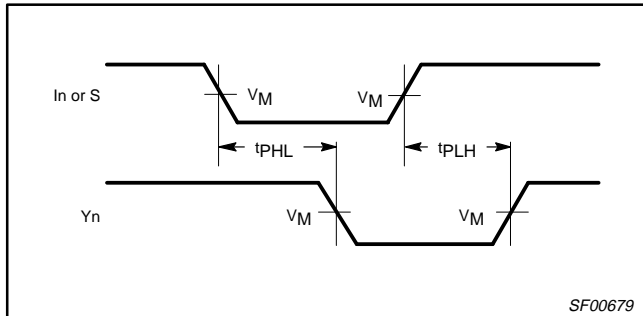

Waveform 1. Propagation Delay, Data and Select to Output

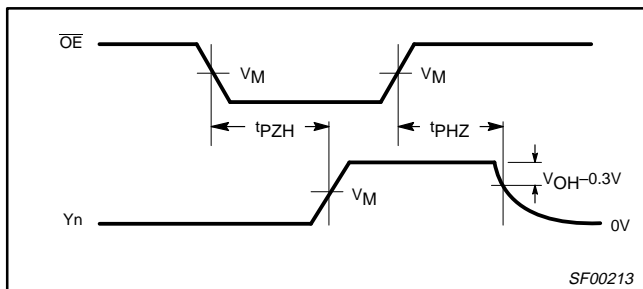

Waveform 2. 3-State Output Enable Time to High Level and Output Disable Time from High Level

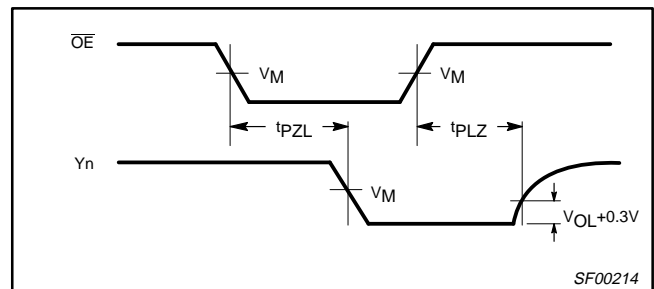

Waveform 3. 3-State Output Enable Time to Low Level and Output Disable Time from Low Level

TEST CIRCUIT AND WAVEFORMS

Test Circuit for 3-State Outputs

Input Pulse Definition

SWITCH POSITION

TEST	SWITCH
t_{PLZ}	closed
t_{PZL}	closed
All other	open

DEFINITIONS:

R_L = Load resistor; see AC electrical characteristics for value.

C_L = Load capacitance includes jig and probe capacitance; see AC electrical characteristics for value.

R_T = Termination resistance should be equal to Z_{OUT} of pulse generators.

family	INPUT PULSE REQUIREMENTS					
	amplitude	V_M	rep. rate	t_w	t_{TLH}	t_{THL}
74F	3.0V	1.5V	1MHz	500ns	2.5ns	2.5ns

SF00678