

# TM-500

## SERIES 176 — Toolmaker's Microscopes

The Mitutoyo TM Series is a toolmaker's microscope well suited for measuring dimensions and angles of workpiece features. It can also be used to check the shape of screws and gears by attaching an optional reticle. The compact body makes it ideal for use on shop-floors with limited

space for measuring instruments.

### FEATURES

- Angle measurement is performed easily by turning the angle scale to align the cross-hair reticle with the workpiece image.
- Illumination intensity can be adjusted.



TM-505



TM-510

### Technical Data

Observation image:	Erect image
Optical tube:	Monocular (diopter adjustable) Depression angle: 30° Reticle: 90° broken cross-hair <b>(176-126)</b>
Angle reading:	Range: 360° Minimum reading: 6' (by vernier)
Eye-piece:	15X <b>(176-116)</b> , View field dia.: 13mm Optional: 10X, 20X
Objective:	2X <b>(176-138)</b> , Working distance: 67mm Optional: 5X, 10X
Total magnification:	30X
Transmitted illumination	
• Light source:	Tungsten bulb (24V, 2W)
• Functions:	With green filter, Light intensity adjustable
Surface illumination:	
• Light source:	Tungsten bulb (24V, 2W)
• Functions:	Light intensity adjustable
Power supply:	100/110/120/220/240V AC, 50/60Hz
Mass:	13.5g (14.5kg: TM-510)

### Angle reading



Refer to the TM-505/510 leaflet (E4158) for more details.

## Optional Accessories

- 176-115:** 10X eyepiece (view field dia.: 13mm)
- 176-116:** 15X projection lens set\*
- 176-117:** 20X eyepiece (view field dia.: 10mm)
- 176-139:** Objective, 5X (W.D.: 33mm, N.A.: 0.10)
- 176-137:** Objective, 10X (W.D.: 14mm, N.A.: 0.14)
- 164-161:** Digimatic micrometer head  
(range: 50mm, reading: 0.001mm)
- 164-162:** Digimatic micrometer head (range: 2"/50mm,  
reading: .00005"/0.001mm)
- 152-390:** Micrometer head for X-axis  
(range: 50mm, reading: 0.005mm)
- 152-389:** Micrometer head for Y-axis  
(range: 50mm, reading: 0.005mm)
- 152-391:** Micrometer head for X-axis  
(range: 2", reading: .0001")
- 152-392:** Micrometer head for Y-axis  
(range: 2", reading: .0001")
- 611635-041:** Rectangular gauge block (25mm)
- 611675-041:** Rectangular gauge block (50mm)
- 611201-241:** Rectangular gauge block (1")
- 611202-241:** Rectangular gauge block (2")
- 383038:** Halogen bulb (24V, 2W)
- 176-204:** Dial indicator attachment for Z-axis  
measurement
- 965013:** SPC cable (2m) for Digimatic micrometer head

### Fixture and Stage accessories

- 990561:** Workpiece clip (2pcs/set)
- 176-106:** Rotary table for TM-505 (effective dia.: 66mm)
- 172-196:** Rotary table for TM-510 (effective dia.:  
100mm)
- 176-105:** Swivel center support for TM-505  
(max. workpiece dia.: 70mm)
- 172-197:** Swivel center support for TM-510  
(max. workpiece dia.: 80mm)
- 172-378:** V-block with clamp
- 176-107:** Holder with clamp

### Illumination units

- 176-366:** Fiber-optic ring light
- 176-203:** Twin-bulb reflected illumination unit
- 176-344:** Bifurcated fiber illuminator

### Reticles

- 176-111:** Concentric circles  
(up to  $\varnothing 4$ mm, 0.05mm increment)
- 176-135:** Concentric circle (up to  $\varnothing .2$ " , .01" increment)
- 176-113:** 55° angle
- 176-114:** 60° angle
- 176-109:** Metric screw threads (pitch = 0.25 - 1mm)
- 176-110:** Metric screw threads (pitch = 1.25 - 2mm)
- 176-140:** ISO metric screw threads  
(pitch = 0.075 - 0.7mm)
- 176-141:** ISO metric screw threads (pitch = 0.75 - 2mm)
- 176-142:** ISO unified screw threads (80 - 28TPI)
- 176-143:** ISO unified screw threads (24 - 14TPI)
- 176-144:** ISO unified screw threads (13 - 10TPI)
- 176-123:** Unified screw threads (80 - 28TPI)
- 176-124:** Unified screw threads (24 - 14TPI)
- 176-125:** Unified screw threads (13 - 10TPI)
- 176-120:** Whitworth screw threads (60 - 26TPI)
- 176-121:** Whitworth screw threads (24 - 18TPI)
- 176-122:** Whitworth screw threads (16 - 11TPI)
- 176-127:** NF screw threads (80 - 28TPI)
- 176-128:** NF screw threads (24 - 14TPI)
- 176-129:** NF screw threads (13 - 10TPI)
- 176-130:** 14.5° involute gear teeth (normal rack type)
- 176-112:** 20° involute gear teeth (normal rack type)

## SPECIFICATIONS

Model No.	TM-505	TM-510
<b>Order No.</b>	<b>176-811*</b>	<b>176-812*</b>
XY stage travel range	50 x 50mm	100 x 50mm
Measurement method	Micrometer head (optional)	Micrometer head (optional)
Floating function	—	—
XY stage table top size	152 x 152mm	240 x 152mm
Effective area of table	96 x 96mm	154 x 96mm
Max. workpiece height	115mm	107mm
Max. stage loading	5kg	5kg
Remarks	—	—

\* To denote your AC power cable add the following suffixes to the order No: **A** for UL/CSA, **CED** for CEE, **CEE** for BS, **D** for CEE, **DC** for CCC, **E** for BS, **K** for EK. **No suffix** is required for JIS/100V  
 (Note) **D** and **E** are not compatible with CE

## DIMENSIONS

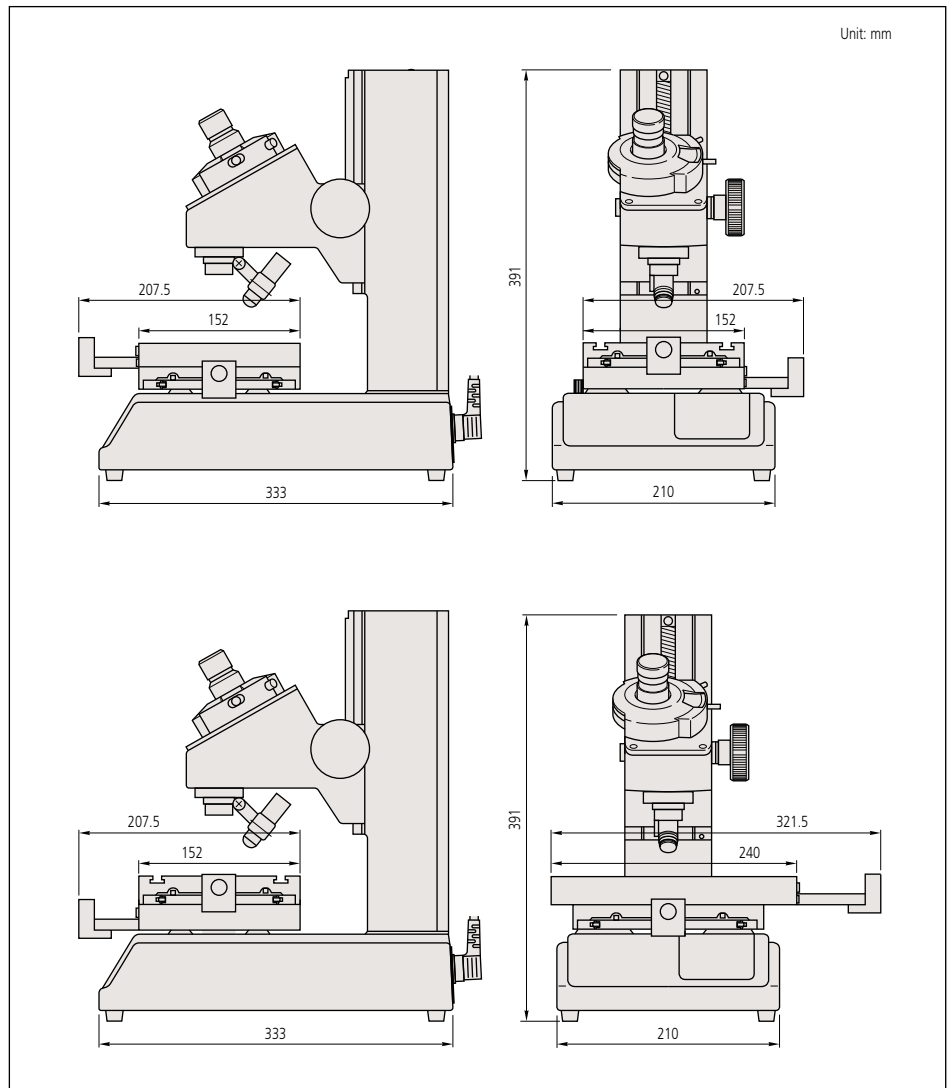

# MF

## SERIES 176 — Measuring Microscopes

The MF measuring microscopes' expandability, such as when used in combination with Mitutoyo's vision unit to boost its performance or data management on a PC, promises further improved measuring efficiency.

### FEATURES

- Observation with a clear and flare-less erect image and a wide field of view
- Measuring accuracy that is the highest in its class (and conforms to JIS B 7153)
- ML series, high-NA objectives that are specially designed for the MF series (long working distance type)

- Illumination unit (reflected/transmitted) selectable from a high-intensity LED or halogen bulb (required)
- Variable aperture diaphragm (reflected/transmitted) allows observation measurement while suppressing light diffraction
- Variety of standardized stages in sizes up to 400x200mm
- Quick-release mechanism useful for moving the stage quickly when measuring workpieces that are large in size or quantity
- Coarse/fine feed handles equipped as standard on both sides allow precise focus and observation measurement regardless of handedness
- High-magnification eyepiece observation up to 2000x
- Standard measuring microscope that has a wide variety of optional accessories including a Vision Unit and various digital CCD cameras



Using optional slide type nosepiece with 2-lens mount (factory set option)

**MF-B2017C**  
XY stage travel range: 200 x 170mm  
(with optional binocular tube)

### Selection of XY stage by travel range

**505C:** 50 x 50mm



**1010C:** 100 x 100mm



**2010B:** 200 x 100mm



**3017C:** 300 x 170mm



**4020C:** 400 x 200mm



### Technical Data

Observation image:	Erect image
Optical tube (optional):	Monocular or binocular tube (depression: 25'), Reticle projection method, with TV mount, Optical path ratio (eyepiece/TV mount: 50/50)
Eyepiece lens (optional):	10X, 15X, 20X
Objective:	3X ( <b>375-037</b> ), W.D.: 72.5mm Optional: 1X, 5X 10X, 20X, 50X, 100X
Transmitted illumination	
• Light source:	Halogen bulb (12V, 50W)
• Optical system:	Telecentric illumination with adjustable aperture diaphragms
• Functions:	Light intensity adjustable, Non-stepped brightness adjustment Surface illumination
• Light source:	Halogen bulb (12V, 150W)
• Optical system:	Koehler illumination with adjustable aperture diaphragms
• Functions:	Light intensity adjustable, Non-stepped brightness adjustment Display unit:
• No. of axis:	2 axes (MF-A type) or 3 axes (MF-B type)
• Resolution:	0.001mm / 0.0005mm / 0.0001mm / .0001" / .00005" / .00001"
• Functions:	Zero-setting, Direction switching, Data output (via RS-232C interface)
Power supply:	100/110/120/220/240V AC, 50/60Hz
Mass:	65.5kg (505C, 1010C) / 69.5kg (2010C) / 130kg (2017C) / 138kg (3017C) / 144kg (4020C)

### Optional Reticles for 3X Eyepiece

- 12AAG838 (12AAG878):** Cross-hair (7 $\mu$ m width)
  - 12AAG836 (12AAG877):** Cross-hair (5 $\mu$ m width)
  - 12AAG873 (12AAG876):** Cross-hair (3 $\mu$ m width)
  - 12AAG839 (12AAG879):** Cross-hair and 45° angle
  - 12AAG840 (12AAG880):** Broken cross-hair and 60° angle
  - 12AAG841 (12AAG881):** Zeiss type chart
  - 12AAG842\*:** 20mm scale (0.1mm reading)
  - 12AAG843\*:** Concentric circle ( $\phi$ 1.2 -  $\phi$ 18mm)
  - 12AAG844\*:** 10mm scale (0.1mm reading)
  - 12AAG845\*:** 5mm scale (0.05mm reading)
  - 12AAG846\*:** 10x10mm section (1mm min.)
  - 12AAG847\*:** Metric screw thread (P = 0.25-1.0)
  - 12AAG848\*:** Metric screw thread (P = 1.25-2.0)
  - 12AAG849\*:** Involute gear tooth (14.5°), module = 0.1 - 1.0
  - 12AAG850\*:** Involute gear tooth (20°), module = 0.1 - 1.0
  - 12AAG851\*:** Unified screw thread (80 - 28TPI)
  - 12AAG852\*:** Unified screw thread (24 - 14TPI)
  - 12AAG853\*:** Unified screw thread (13 - 10TPI)
  - 12AAG854\*:** Concentric circle ( $\phi$ .01" -  $\phi$ .2")
- ( ) : for MF-U models, \* : MF/MF-U compatible

Reticle mount (standard accessory) for MF models for MF-U models

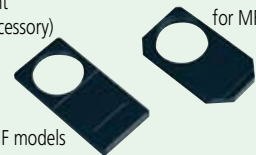

90° chain line  
Line width: 5 $\mu$ m  
(standard accessory)



Refer to the MF /MF-U leaflet (E4153) for more details.



# MF-U

## SERIES 176 — High-power Multi-function Measuring Microscopes

### FEATURES

- Observation with a clear and flare-less erect image and a wide field of view
- Measuring accuracy that is the highest in its class (and conforms to JIS B 7153)
- Proven high-NA objectives from the FS optical system (long working distance type)
- Integration of metallurgical and measurement microscope functions provides high-resolution observation and high-accuracy measurement solution
- Illumination unit (reflected/transmitted) selectable from a high-intensity LED or halogen bulb (required)
- Variable aperture diaphragm (reflected/transmitted) allows observation measurement while suppressing light diffraction
- Variety of standardized stages in sizes up to 400 × 200 mm
- Quick-release mechanism useful for moving the stage quickly when measuring workpieces that are large in size or quantity
- High-magnification eyepiece observation up to 4000X
- Low-noise design

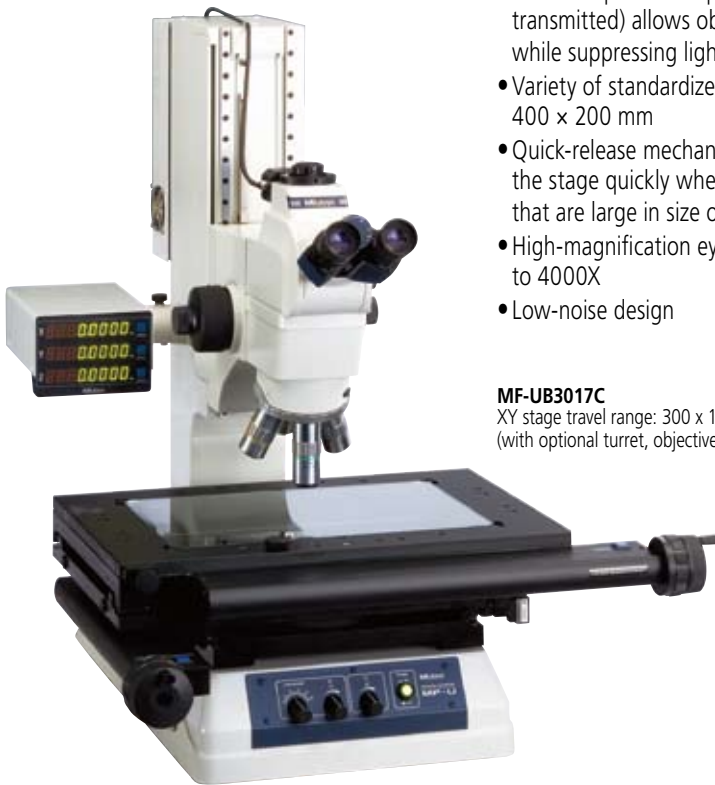

**MF-UB3017C**  
XY stage travel range: 300 x 170mm  
(with optional turret, objective and fiber illumination)

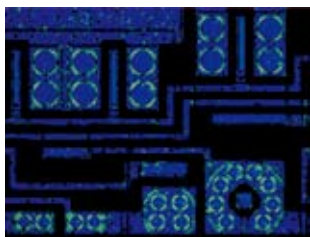

**Polarized light observation:**  
Observing only the filtered light that vibrates in one direction. Used for observing materials with special optical characteristics, such as mineral and liquid crystal.



**Differential interference contrast (DIC) observation:**  
Effective in detecting fine scratches and steps on the surface of metal, liquid crystal, and semiconductors.



**Dark field (DF) observation:**  
Observing only the scattered light by shutting down the direct light to the objectives. The scratches and dust that cannot be viewed in the bright view field can be observed by this method in high-contrast.

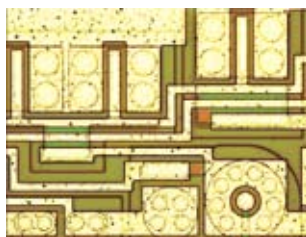

**Bright field (BF) observation:**  
Most common method of observation. Observing directly the light reflected from the surface of the workpiece.

### Technical Data

Observation image:	Erect image
Optical tube:	Siedentoph type (pupil distance adjustment: 51 - 76mm), 1X tube lens, Binocular tube (depression: 30°), Reticle projection method, with TV mount, Optical path ratio (eyepiece/TV mount: 50/50)
Eyepiece lens:	10X (field No.: 24mm), Optional: 15X, 20X
Turret (optional):	Manual or power
Objective (optional):	M / BD Plan Apo objective from 1X to 100X (Refer to page J-36 for more details.)
<b>Transmitted illumination</b>	
• Light source:	Halogen bulb (12V, 50W)
• Optical system:	Telecentric illumination with adjustable aperture diaphragms
• Functions:	Light intensity adjustable, Non-stepped brightness adjustment
<b>Surface illumination</b>	
• Light source:	Optional halogen illumination unit (fiber-optic cold light illumination)
• Optical system:	Koehler illumination with adjustable aperture diaphragms
• Functions:	Light intensity adjustable, Non-stepped brightness adjustment
<b>Display unit:</b>	
• No. of axis:	2 axes or 3 axes
• Resolution:	0.001mm / 0.0005mm / 0.0001mm / .0001" / .00005" / .00001"
• Functions:	Zero-setting, Direction switching, Data output (via RS-232C interface)
Power supply:	100/110/120/220/240V AC, 50/60Hz
Mass:	65.5kg (505C, 1010C) / 69.5kg (2010C) / 130kg (2017C) / 138kg (3017C) / 144kg (4020C)

### Selection of XY stage by travel range

	<b>505C:</b> 50 x 50mm
	<b>1010C:</b> 100 x 100mm
	<b>2010C:</b> 200 x 100mm
	<b>2017C:</b> 200 x 170mm
	<b>4020C:</b> 400 x 200mm

## Optional Accessories

- 378-857:** 15X eyepiece set (view field dia.: 16mm)  
**378-858:** 20X eyepiece set (view field dia.: 12mm)  
 ———: Objective (See page J-36.)  
**378-018:** Adjustable manual BF turret  
**378-116:** Adjustable power BF turret  
**176-211:** Adjustable manual BF/DF turret  
**378-210:** Adjustable power BF/DF turret  
 ———: Reticles (See page J-18.)  
**178-092:** Polarization unit  
**378-076:** DIC unit for 100X, SL80X, SL50X objective  
**378-078:** DIC unit for 50X, SL20X objective  
**378-079:** DIC unit for 20X objective  
**378-080:** DIC unit for 10X, 5X objective  
**12AAA643:** ND2 color filter  
**12AAA644:** ND8 color filter  
**12AAA645:** GiF filter  
**12AAA646:** LB80 color filter  
**375-054:** 0.5X camera adapter  
 (with C-mount adapter)  
**970441:** C-mount adapter  
**513667:** Halogen bulb (24V, 50W)  
**12BAB345:** Halogen bulb (long life type, 24V, 50W)  
**517181:** Halogen bulb (24V, 100W)  
**12BAD602:** High intensity halogen bulb (24V, 100W)  
**176-308:** Vibration damping stand  
**176-309:** Mounting stand  
**375-056:** Stage micrometer  
**12AAA165:** Lens cleaning kit  
**12AAA846:** Foot switch

Illumination units (Refer to page J-25.)

- 176-315:** Halogen illumination unit (12V, 100W)  
**176-316:** Halogen illumination unit (12V, 150W)  
**176-343:** Twin fiber-optics illuminator  
**12AAG806:** GiF color filter (for **176-315**)  
**12AAG807:** LB80 color filter (for **176-315**)

Fixture and Stage accessories (Refer to page J-15.)

- 176-107:** Holder with clamp\*  
**172-378:** V-block with clamp\*  
 (max. workpiece dia.: 25mm)  
**172-197:** Swivel center support\*  
 (max. workpiece dia.: 80mm)  
**176-305:** Rotary stage with fine feed knob for  
 505C/1010C/2010C models  
**176-306:** Rotary stage with fine feed knob for  
 2017C/3017C models

\*Fixture mount adapter (**176-310**) is required for 1020B models.  
 \*Fixture mount adapter (**176-304**) is required for 1720B/1730B models.



Refer to the MF /MF-U leaflet (E4153) for more details.

## SPECIFICATIONS

Model No. (XY stage size)	505C	1010C	2010C	2017C	3017C	4020C	
<b>Order No.</b>	MF-UA	<b>176-667*</b>	<b>176-668*</b>	<b>176-669*</b>	<b>176-670*</b>	<b>176-671*</b>	<b>176-672*</b>
	MF-UB	<b>176-687*</b>	<b>176-688*</b>	<b>176-689*</b>	<b>176-690*</b>	<b>176-691*</b>	<b>176-692*</b>
	MF-UC	<b>176-673*</b>	<b>176-674*</b>	<b>176-675*</b>	<b>176-676*</b>	<b>176-677*</b>	<b>176-678*</b>
	MF-UD	<b>176-693*</b>	<b>176-694*</b>	<b>176-695*</b>	<b>176-696*</b>	<b>176-697*</b>	<b>176-698*</b>
XY stage travel range	50 x 50mm	100 x 100mm	200 x 100mm	200 x 170mm	300 x 170mm	400 x 200mm	
Z-axis travel range	150mm	150mm	150mm	220mm	220mm	220mm	
Focusing method	Manual focusing (coarse focusing: 10mm/rev., fine focusing: 0.1mm/rev.)						
Measurement method	Linear encoder (2-axis model: X / Y-axis, 3-axis model: X / Y / Z-axis)						
Resolution (switchable)	0.001mm / 0.0005mm / 0.0001mm / .0001" / .00005" / .00001"						
Measuring accuracy (at 20°C)	XY-axis: (2.2+0.02L) $\mu$ m, L = Measuring length (mm) when not loaded, JIS B 7153						
Indication accuracy (at 20°C)	Z-axis: (5+0.04L) $\mu$ m, L = Measuring length (mm)						
Floating function	X and Y axes with Quick-release mechanism						
XY stage top size	280 x 280mm	280 x 280mm	350 x 280mm	410 x 342mm	510 x 342mm	610 x 342mm	
Effective glass size	180 x 180mm	180 x 180mm	250 x 150mm	270 x 240mm	370 x 240mm	440 x 240mm	
Swiveling function	—	—	—	$\pm$ 5° (left)	$\pm$ 5° (left)	$\pm$ 3° (left)	
Max. stage loading	10kg	10kg	10kg	20kg	20kg	15kg	
Max. workpiece height	150mm	150mm	150mm	220mm	220mm	220mm	

\* The following suffixes to the order No. (e.g.: **176-667-10**):

-10 for English User's Manual 11 for Chinese user's manual, No suffix is Japanese user's manual

## Selection of machine type

Machine type	MF-UA	MF-UB	MF-UC	MF-UD
Observation type	Bright field (BF)	Bright field (BF)	Bright / Dark field (BF/DF)	Bright / Dark field (BF/DF)
Measurement system	X and Y-axis (2 axes)	X, Y and Z-axis (3 axes)	X and Y-axis (2 axes)	X, Y and Z-axis (3 axes)

## Illumination Unit

Applicable Illumination Unit	LED	Halogen
<b>Order No.</b>	<b>176-346*</b>	<b>176-348*</b>

Note: Because the "Generation C type" does not have equipped the illumination unit, it is necessary to select the either LED illumination unit or Halogen illumination unit.

\*To denote your AC power cable add the following suffixes to the order No.: **A** for U/USA, **C** for Taiwan, **D** for CEE, **DC** for CCC, **E** for BS, **K** for EK. **No suffix** is required for JIS/100V

## DIMENSIONS

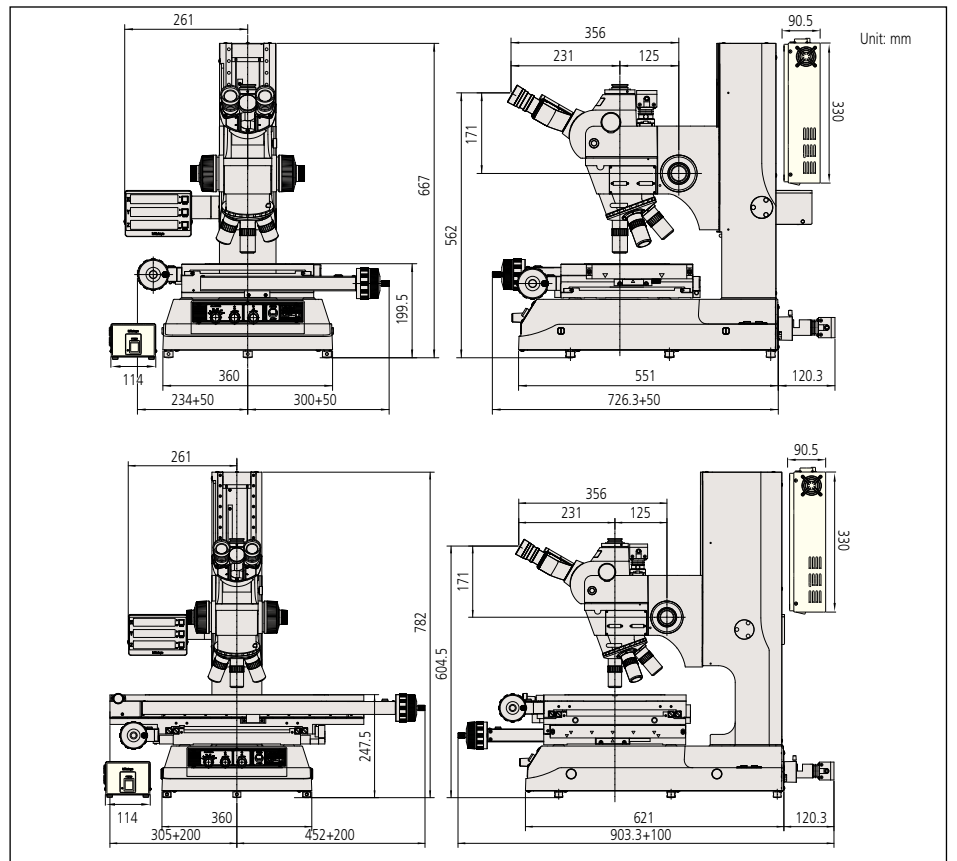

# Hyper MF/MF-U

## SERIES 176 — High-Accuracy Measuring Microscopes

### FEATURES

- The world highest accuracy XY measuring accuracy of  $(0.9+3L/1000)\mu\text{m}$
- Selectable LAF (Laser Auto Focus) function
- High operability and repeatability
- Three-axis motorized control
- Power-drive auto focus unit is a standard feature.

**Hyper MF-U**  
with optional optical tube,  
turret and objectives



### SPECIFICATIONS

Model No.	Hyper MF-B2515B	Hyper MF-UB2515B	Hyper MF-UD2515B	Hyper MF-UE2515B	Hyper MF-UF2515B
Order No. (mm)	176-430*	176-431*	176-432*	176-433*	176-434*
Observation type	BF	BF	BF or BF/BD	BF	BF or BF/BD
Digital counter	—	—	—	—	—
Laser auto focus function	—	—	—	Available	Available
XY stage travel range	250 x 150mm	250 x 150mm	250 x 150mm	250 x 150mm	250 x 150mm
Measuring unit	Linear encoder	Linear encoder	Linear encoder	Linear encoder	Linear encoder
Resolution	0.01 $\mu\text{m}$	0.01 $\mu\text{m}$	0.01 $\mu\text{m}$	0.01 $\mu\text{m}$	0.01 $\mu\text{m}$
Measuring accuracy (at 20°C)	$(0.9+3L/1000)\mu\text{m}$ , L = XY axis measuring length (mm) when not loaded				
Drive system (X, Y, Z-axis)	Motor-driver control with the joystick				
XY stage top size	460 x 350mm	460 x 350mm	460 x 350mm	460 x 350mm	460 x 350mm
Effective glass size	300 x 200mm	300 x 200mm	300 x 200mm	300 x 200mm	300 x 200mm
Swiveling function	$\pm 3^\circ$	$\pm 3^\circ$	$\pm 3^\circ$	$\pm 3^\circ$	$\pm 3^\circ$
Max. stage loading	30kg	30kg	30kg	30kg	30kg
Max. workpiece height	150mm	150mm	150mm	150mm	150mm

\* To denote your AC power cable add the following suffixes to the order No.: **A** for UL/CSA, **C** for Taiwan, **D** for CEE, **DC** for CCC, **E** for BS, **K** for EK, **No suffix** is required for JIS/100V

### Technical Data: Hyper MF

- Observation image: Erect image  
 Optical tube: Monocular or binocular tube (optional, depression: 25°), Reticle projection method, with TV mount, Optical path ratio (eyepiece/TV mount: 50/50)
- Eyepiece lens (optional): 10X, 15X, 20X  
 Objective: 3X (**375-037-1**), W.D.: 77.0mm  
 Optional: 1X, 5X 10X, 20X, 50X, 100X
- Transmitted illumination
- Light source: Halogen bulb (12V, 100W) (fiber-optic cold light illumination)
  - Optical system: Telecentric illumination with adjustable aperture diaphragms
  - Functions: Light intensity adjustable, 100 steps brightness adjustment
- Surface illumination
- Light source: Halogen bulb (12V, 50W)
  - Optical system: Koehler illumination with adjustable aperture diaphragms
  - Functions: Light intensity adjustable, 100 steps brightness adjustment
- Data output: Via RS-232C interface  
 Power supply: 100/110/120/220/240V AC, 50/60Hz  
 Dimensions: 880x913x730mm (main unit)  
 160x476x381 (power unit)  
 Mass: 250kg (main unit), 14kg (power unit)

### Technical Data: Hyper MF-U

- Observation image: Erect image  
 Optical tube: Siedentoph type (pupil distance adjustment: 51 - 76mm), 1X tube lens, Binocular tube (depression: 25°), Reticle projection method, with TV mount, Optical path ratio (eyepiece/TV mount: 50/50)
- Eyepiece lens: 10X (field No.: 24mm),  
 Optional: 15X, 20X
- Turret (optional): Power  
 Objective (optional): M / BD Plan Apo objective from 1X to 100X (Refer to page J-36 for more details.)
- Transmitted illumination
- Light source: Halogen bulb (12V, 100W)
  - Optical system: Telecentric illumination with adjustable aperture diaphragms
  - Functions: Light intensity adjustable, 100 steps brightness adjustment
- Surface illumination
- Light source: Halogen bulb (12V, 50W)
  - Optical system: Koehler illumination with adjustable aperture diaphragms
  - Functions: Light intensity adjustable, 100 steps brightness adjustment
- Data output: Via RS-232C interface  
 Power supply: 100/110/120/220/240V AC, 50/60Hz  
 Dimensions: 880x913x770mm (main unit)  
 160x476x381 (power unit)  
 Mass: 255kg (main unit), 14kg (power unit)



Refer to the Hyper MF/MF-U leaflet (E4267) for more details.

### Optional Accessories

See page J-19 for Hyper MF models.  
See page J-21 for Hyper MF-U models.



**QM-Data200**  
2-D data processing unit  
(Refer to page J-26 for more details.)



**Vision Unit**  
PC-based vision measuring system  
(Refer to page J-28 for more details.)

### DIMENSIONS

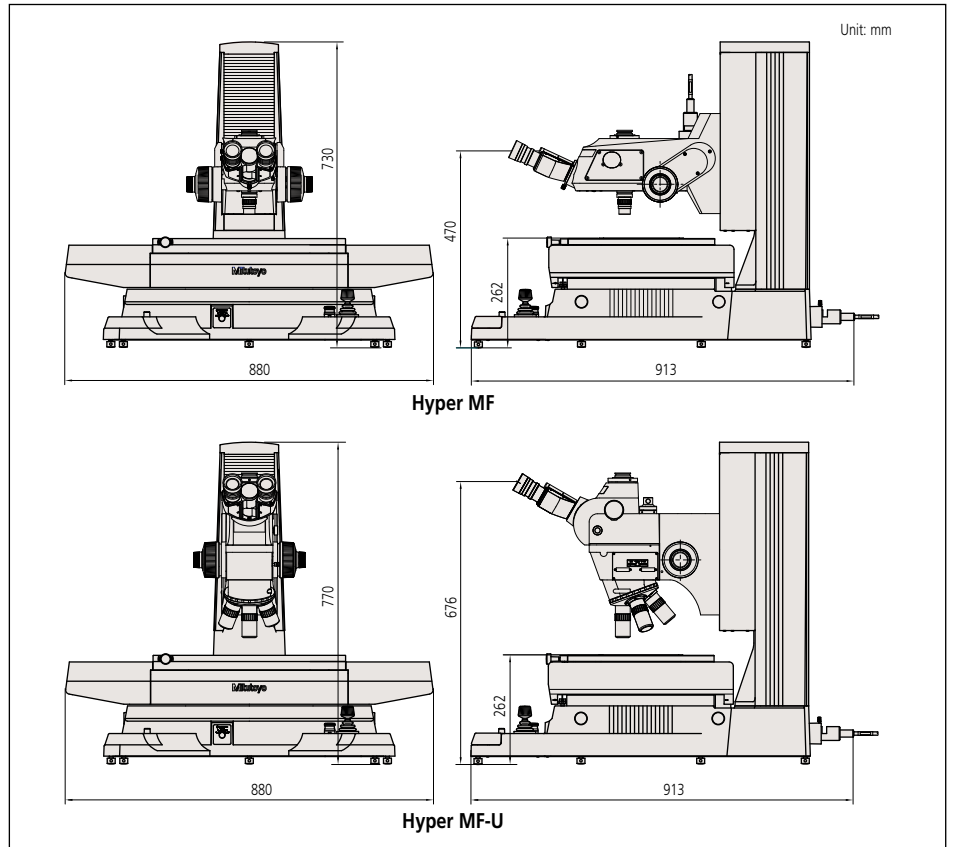

### Large, Highly Accurate XY Stage

The XY stage is a massive, highly stable design created using mechanical techniques developed over Mitutoyo's long years of experience in manufacturing precision measuring microscopes. Maximum stage loading is 30kg and a range of useful fixtures is available that includes a wafer holder and swivel-center support.

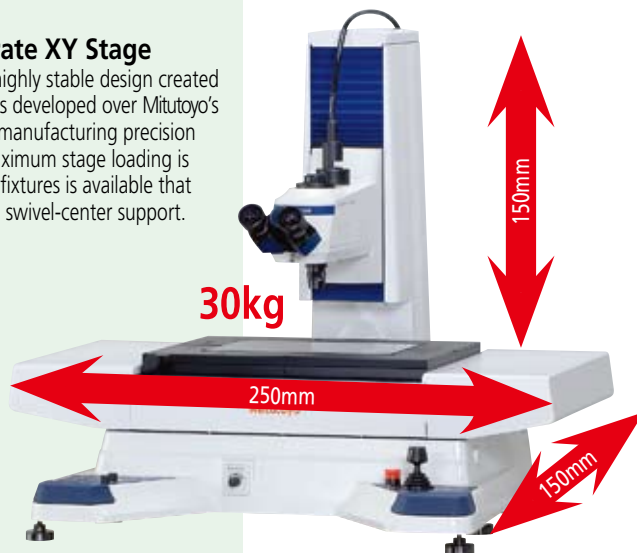

### Three-axis Motor-driven Joystick

The X, Y, and Z axes are driven and controlled with one joystick that serves as the nerve center of operation. Speed control is possible from high-speed traverse of the stage to ultra low-speed, precise positioning of a workpiece.



### Highly Accurate Digital Scales

These microscopes are equipped with highly accurate digital glass scales on all three axes. Mitutoyo produces glass scales in an underground laboratory where the temperature and humidity are constant throughout the year. The XY (stage) and Z (optical tube) displacements are displayed digitally.



### LAF Optical Tube

The LAF (Laser Auto Focus) optical tube can be selected. The LAF system achieves high repeatability when measuring minute steps, etc., enabling difficult measurements with minimum fatigue.

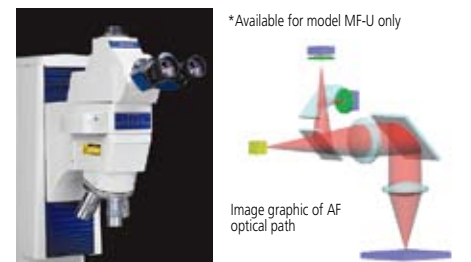

The LAF uses a low-power laser that corresponds to Class 2 (visible radiation) of JIS C6802/1997, Safety of Laser Products.



# Accessory for Measuring Microscope

## Focus Pilot FP-05

### FEATURES

- By installing this system on the camera mount of an MF series measuring microscope and projecting the focusing chart onto the workpiece surface, the focal point can be detected with high-accuracy and high-repeatability.
- The brightness of the chart can be adjusted.
- A wide view field observation on the monitor is made possible with the use of a CCD camera (C-mount adapter is included.)

- Four types of chart patterns are available. The pattern should be selected in accordance with the type of workpiece surface texture.



### SPECIFICATIONS

Order No.	375-057*	375-058*	375-067*	375-068*
Applicable microscopes	MF C models		MF-U C models	
Light source	Green LED	Red LED	Green LED	Red LED
Magnification	0.5X, Accuracy: 0.1%**			
Camera adapter	C-mount (provided)			
Applicable CCD camera	Up to 2/3-inch			
Mass	1.8kg		1.8kg	

\* To denote your AC power cable add the following suffixes to the order No.:  
**A** for UL/CSA, **C** for Taiwan, **D** for CEE, **DC** for CCC, **E** for BS, **K** for EK,  
**No suffix** is required for JIS/100V  
 \*\* Within 2/3 area from the center of view field



## Power Focus Unit



### SPECIFICATIONS

Order No.	Please contact us
Applicable microscopes	MF-C models, MF-UC models
Resolution	0.4μm
Drive speed	3.2mm/s
Power supply	100 - 240V AC, 50/60Hz
Dimensions (WxDxH)	Control box: 108 x 72 x 193mm

## Manual and Power Turrets



### SPECIFICATIONS

Order No.	176-211	378-018	176-210*	378-016*	378-116*
Observation type	BD	BF	BD	BF	BF
No. of objective mounts	4-mount	4-mount	4-mount	4-mount	5-mount
Driving method	Manual		Motor		
Power supply	—	—	AC100V - 240V		
Dimensions (W x D x H)	—	—	Turret: 164x65x137 Control Box: 108x72x193		

\* To denote your AC line voltage add the following suffixes to the order No. (e.g.:  
**176-210A**):  
**A** for UL/CSA, **D** for CEE, **E** for BS, **DC** for China, **K** for EK, **C** for Taiwan, No  
 suffix is required for JIS/100V

## Stage Micrometer

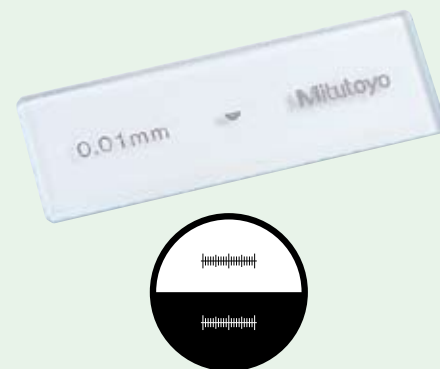

### SPECIFICATIONS

Order No.	375-056
Range	1mm
Graduations	0.01mm
Accuracy (at 20°C)	(1+L)μm, L = Measuring length (mm)
Dimensions (WxD)	76 x 26mm
Mass	16g

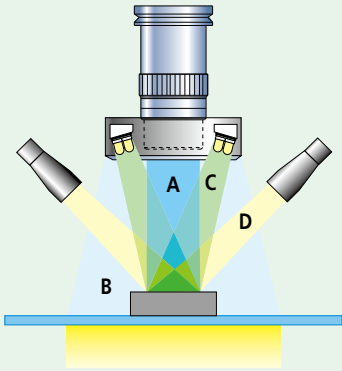

**A: Vertical surface illumination (Halogen)**



PCB



HDD suspension

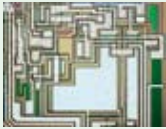

IC circuit

**B: Ring fiber-optics illumination**



Flexible PCB



PCB



Electric parts

**C: LED Ring Illumination**



HDD suspension



PCB



Black resin molded parts

**D: Twin fiber-optics illumination**



IC package



Garnet



PCB

## Twin fiber-optics illuminator

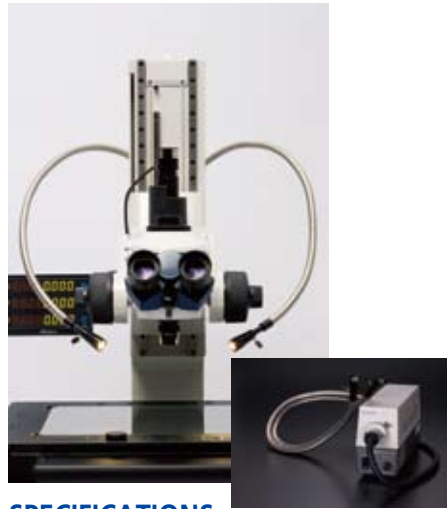

### SPECIFICATIONS

Order No.	176-343*
Applicable microscopes	MF, MF-U models
Length of fiber cable	700mm
Light source	Halogen bulb (12V, 100W) (517181: halogen bulb)
Dimensions (W x D x H)	Light unit: 235 x 76 x 120mm

\* To denote your AC power cable add the following suffixes to the order No.: **A** for UL/CSA, **C** for Taiwan, **D** for CEE, **DC** for CCC, **E** for BS, **K** for EK, **No suffix** is required for JIS/100V

## Ring fiber-optics illuminator

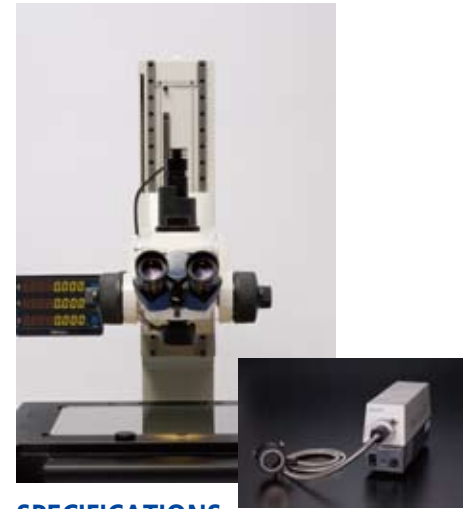

### SPECIFICATIONS

Order No.	176-366*
Applicable microscopes	MF models
Length of fiber cable	1000mm
Light source	Halogen bulb (12V, 100W) (517181: halogen bulb)
Dimensions (W x D x H)	Light unit: 235 x 76 x 120mm

\* To denote your AC power cable add the following suffixes to the order No.: **A** for UL/CSA, **C** for Taiwan, **D** for CEE, **DC** for CCC, **E** for BS, **K** for EK, **No suffix** is required for JIS/100V

## LED Ring Illuminator

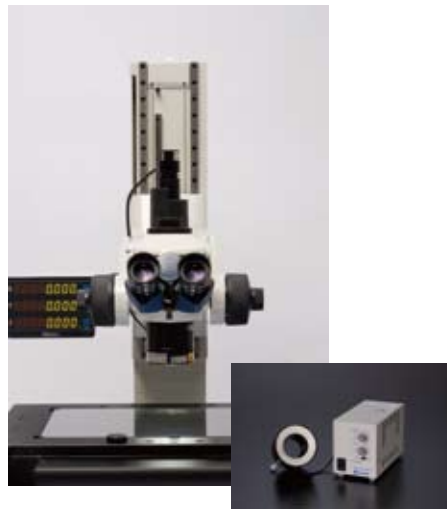

### SPECIFICATIONS

Order No.	176-367-2*
Applicable microscopes	MF models with 1X/3X/5X/10X objective
Light source	White LED
Length of LED cable	1500mm

\* To denote your AC power cable add the following suffixes to the order No.: **A** for UL/CSA, **C** for Taiwan, **D** for CEE, **DC** for CCC, **E** for BS, **K** for EK, **No suffix** is required for JIS/100V

## LED Ring Light (for FS Objectives)



### SPECIFICATIONS

Order No.	Please contact us
Applicable microscopes	MF models with 1X/3X/5X objective
Light source	Supplied from microscope (surface illumination)

# QM-Data200

## SERIES 264 — 2-D Data Processing Unit

The QM-Data200 is a geometric readout/analysis unit for optical instruments such as a profile projectors. This unit features powerful 2-D coordinate measurement capabilities with easy-to-use key operation. The QM-Data200 improves operator productivity, minimizes errors and saves total measurement time and production cost.

### FEATURES

- Informative graphic displays on the large LCD screen make for easy measurement operations.
- One-key operation for combined measurements that are often used (circle-circle distance, etc.)
- The AI measurement function (automatic identification of measuring item) eliminates switching between the measurement command keys.

#### QM-Data200

No.: 264-145\* (stand-mount type)

No.: 264-146\* (arm-mount type)

No.: 264-149\* (for Hyper MF / MF-U)

\* To denote your AC power cable add the following suffixes to the order No.: **A** for UL/CSA, **C** for Taiwan, **D** for CEE, **E** for BS, **No suffix** is required for JIS/100V



QM-Data200  
Stand-mount type

### • Graphic display

Measurement information and data are visualized on the back-lit LCD display with graphical interfaces. The geometric feature that you selected is displayed with the probing navigator. The measurements map and blink indication show you the probing points and sequences. Simply probe points and click by following the blink indicator. Measurements can be easily completed even by a beginner. This improves operation accuracy and reduces errors and time.

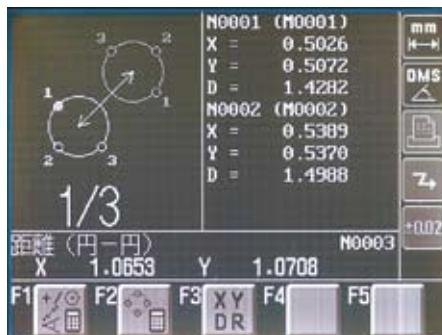

- Equipped with a measurement procedure teaching function and measuring position navigation in Repeat mode.
- The user menu function allows the user to register measurement commands or part programs to create custom menus.
- Tolerance zone measurement of data processing results and various statistical processing routines for each item are available.
- Measurement result output to "MS-Excel"\* in spreadsheet (CSV) format.
- The measurement procedure and measurement result can be saved, using the optional floppy disk drive unit.
- Two models are available: a stand-alone type with tilt system and a flexible arm type that can be mounted on a Profile Projector.

\* Microsoft Excel is a registered trademark of Microsoft Corporation.

### Technical Data

Resolution:	0.0001mm
Program functions:	Part program creation, execution, editing
Statistical processing:	Number of data, maximum value, minimum value, mean value, standard deviation, range, histogram
Element memory:	Maximum of 1000 elements
Element recall:	Point, line, circle, distance, ellipse, rectangular hole, slotted hole, intersection and intersecting angle
Element key-in:	Point, line, circle
Display system:	Monographic LCD (320 x 240 dots, with LED back light)
Measurement result file output:	RS-232C output (CSV format, MUX-10F format)
Display language:	Japanese/English/German/French/Italian/Spanish/Portuguese/Cheskey/Chinese (simplified/traditional), Korean
Data input:	RS-232C, XYZ-axis signal, Footswitch
Data output:	RS-232C, Printer, Floppy disk drive unit
Power supply:	100V AC to 240V AC
Mass:	2.9kg (stand-mount type) 2.8kg (arm-mount type)

### • Intuitive panel design

The QM-Data200 employs "Geometry Keys" to accelerate the measurement process. The probing routine of standard geometric features and combinations are designed with Geometry Keys on the front panel. Simply clicking a key and then capturing the feature coordinates means you can complete the measurement quickly and accurately. This improves operator productivity, reduces errors and save operation time and cost.

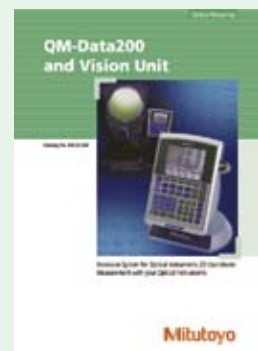

Refer to the QM Data200 and Vision Unit leaflet (E4232) for more details.

## Optional Accessories

- 12AAH035:** Floppy disk drive unit (USB type)
- 12AAD033:** Receipt printer (for 230V)
- 12AAD034:** Receipt printer (for 120V)
- 908353:** Printer paper for receipt printer
- 12AAA804:** Printer cable (2m)
- 937179T:** Foot switch
- 172-270:** Adjustable stand
- 12AAD193:** Connection cable B
- 12AAD194:** Connection cable C
- 12AAD195:** Connection cable D
- 12AAD196:** Connection cable E
- 12AAA807:** RS-232C cable (2m)
- 12AAG920:** RS-232C cable (3m)

## Technical Data

### Image detection

- Directivity: Non-direction
- Min. diameter:  $\varnothing 2\text{mm}$  on the screen
- Min. width: 1mm on the screen
- Max. moving speed: 1000mm/s

### Applicable illumination

- Type: Surface / Contour illumination
- Range: 30Lux to 1500Lux on the screen  
Bright-Dark field difference: 20Lx  
1 $\mu\text{m}$  in contour illumination

### Repeatability:

Function: Creating, performing, and editing measuring procedures

## Optional Accessories

- 12AAE671:** Detector attachment A (for  $\varnothing 250$  to  $\varnothing 350\text{mm}$  screen of PJ-A3000, PJ-H30, PH-3515, series)
- 12AAE672:** Detector attachment B (for  $\varnothing 500$  to  $\varnothing 600\text{mm}$  screen of PV-5110, PV-600A series)



## SYSTEM DIAGRAM

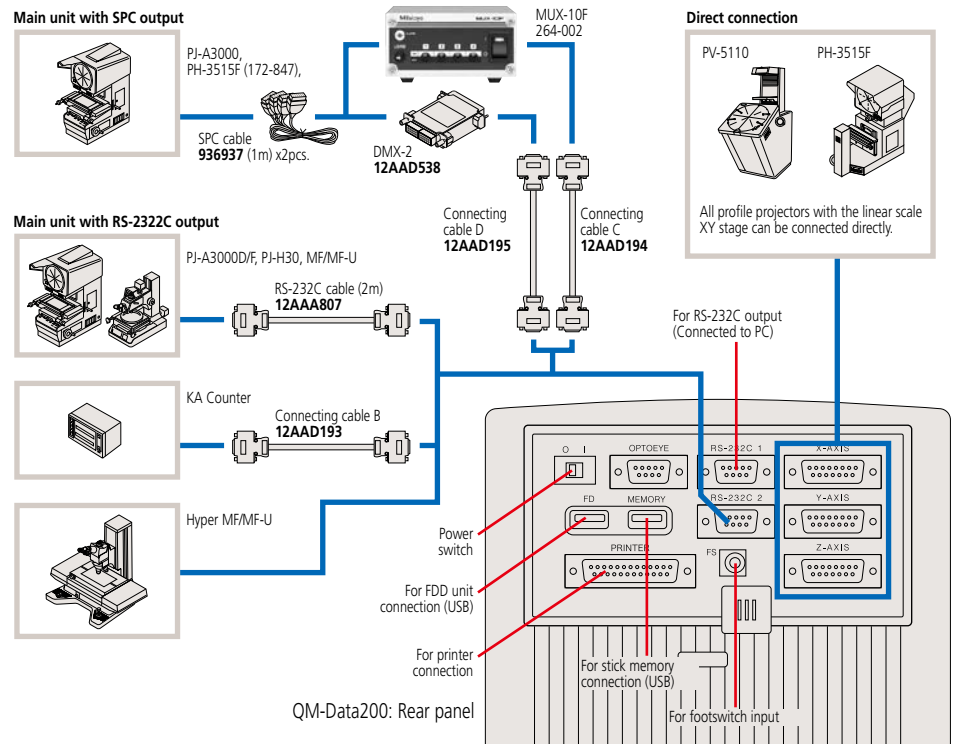

## OPTOEYE-200: No. 332-151

The OPTOEYE-200 Image Edge Sensor eliminates human errors which may be involved in visual alignment, ensuring speedy, accurate, and consistent measurements, regardless of operator's skill.

- Bright and dark buttons allow easy calibration.
- OPTOEYE can be powered by QM-Data200 via the connecting cable. It means that no AC adapter is required.

## FEATURES

- OPTOEYE-200 adopts a thin fiber-optic cable for detector connection to offer easy set-up and smart operation without obstructing your vision.



## DIMENSIONS

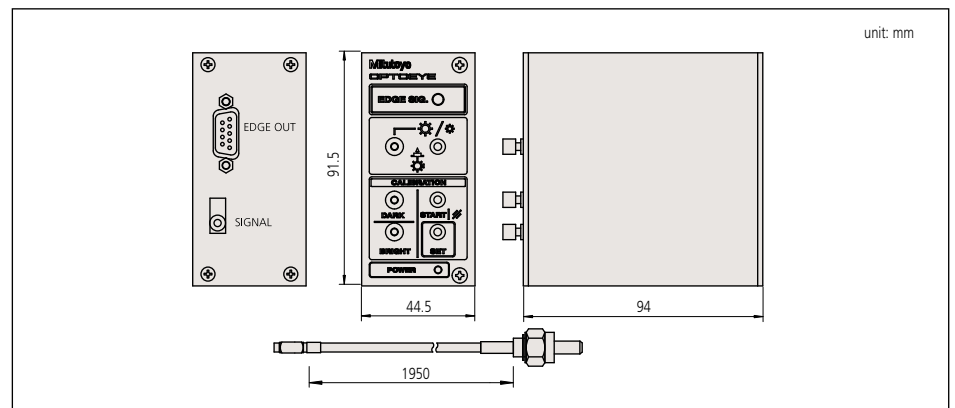

# Vision Unit

## SERIES 359 — Vision System Retrofit for Microscopes

### FEATURES

- The automatic edge-detection tools and various macro icons allow measurement in one easy step.
- The graphics and measurement navigation functions facilitate operation.
- Image data input/storage function.
- Measurement results are output to MS-Excel®. This lets the user generate an inspection table on the same computer.
- Allows the tolerance zone measurement of measurement results and various types of statistical processing for each item.
- Combined use with the focus pilot provides high-accuracy in height measurements. (Patent pending)
- A series of measuring operations can be performed using just one screen display.
- The auto-brightness control function faithfully reproduces the type and degree of illumination used. (This function is limited to the MF/MF-U series.)

### Technical Data

Projected image:	Inverted image
Camera unit	
• Image sensor:	1/2" color CMOS camera
• Resolution:	0.0001mm
• Dimensions:	100 x 58 x 89mm (W x D x H)
• Mass:	0.4kg
Adapter unit	
• Operating software:	QSPAK VUE (optional)
• Dimensions:	45 x 123mm
• Magnification:	0.5X
• Mass:	0.3kg
Magnifications:	21X - 210X on 19" monitor
Standard accessory:	Foot switch ( <b>12AAJ088</b> )

### QSPAK Measurement Window

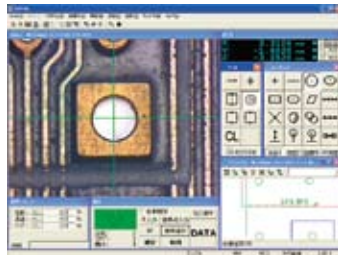

### QSPAK, optional software

#### For observation/comparison of form

- Template matching function
- Manual pattern matching function

#### For simple measurement

- One-click edge detection tool function
- Smart tool function
- User macro function

#### For repeated measurement/auto-measurement

- Quick navigation function
- Playback function
- Graphic function
- External data output function
- Statistical calculation function

Vision Unit  
No.: 359-737 (for MF C)  
No.: 359-739 (for MF-UC)



The PC system, QSPAK software and microscope are optional.

### One-click Edge Detection

Just by clicking the mouse near the edge of a workpiece, QSPAK automatically scans the edge and detects it, showing its coordinates. This function also works with the point tool, box tool, circle tool and auto-focus tool.



### Graphic Window

The measurement results and measured elements are plotted in the graphic window in real-time. By using this function the user can check the current measuring position at a glance. The graphic window can be used for geometrical calculation.

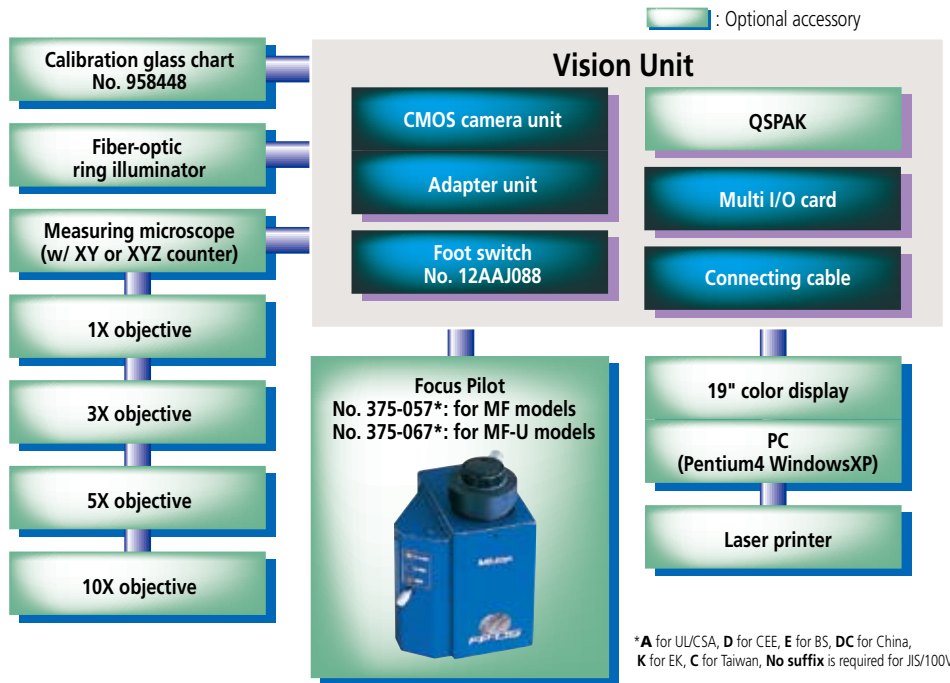
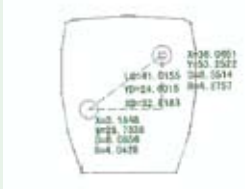

\*A for UL/CSA, D for CEE, E for BS, DC for China, K for EK, C for Taiwan, No suffix is required for JIS/100V

# FS-300

## SERIES 378 — High Power Inspection Microscope

The FS-300 is designed for inspecting micro-components such as IC chips and video head parts. The optical system features ultra-long working distance objectives, wide view field eyepieces, and independent correction for lateral chromatic aberration.

### FEATURES

- The complete FS-300 system can be composed of a variety of components for meeting diverse applications.
- Available with or without a transmitted-light illuminator.
- Ultra-long working distance objectives provide easy manipulation of workpieces.
- Easy switching between bright-field illumination and dark-field illumination.
- Optional accessories widen the range of applications.



FS-300 with optional accessories

### SPECIFICATIONS

Main unit	Observation system	Bright field (BF): <b>378-320, 378-322, 378-324, 378-326</b> Bright/dark field (BF/DF): <b>378-321, 378-323, 378-325, 378-327</b>	
	Reflected illumination	Koehler illumination with aperture diaphragm (centering mechanism) and field stop 12V/100W halogen lamp (non-stepped brightness adjustment) With filter mounting slot (2-slot) with BF/DF switching slide ( <b>378-321, 378-323, 378-325, 378-327</b> only)	
	Transmitted illumination	12V/100W fiber illumination (non-stepped brightness adjustment) with aperture diaphragm ( <b>378-323, 378-324, 378-326, 378-327</b> only)	
	Focus adjustment	With concentric coarse and fine focusing wheels (right and left) Fine adjustment: 0.1mm/rev. for 32mm travel range Coarse adjustment: 3.8mm/rev. for 32mm travel range	
Power turret	Inward type with 4 lens mounts		
Workstage	Travel stroke: 356 x 306mm with X-Y-axis fine feed knobs and coarse travel handle		
Optical tube	Type	Trinocular tube (erect image)	
	Field number	24	
	Depression angle	Fixed 20°: <b>378-320, 378-321, 378-322, 378-323</b> Adjustable 0° to 20°: <b>378-324, 378-325, 378-326, 378-327</b>	
	Intermediate image mag.	1X	
	Optical pass ratio	Siedentopf type, adjustment range: 51 - 76mm	
	Pupil distance	Siedentopf type, adjustment range: 51 - 76mm	
Eyepiece	Field of view	10X/ø30: <b>378-320, 378-321, 378-322, 378-323</b> 10X/ø24: <b>378-324, 378-325, 378-326, 378-327</b>	
		Applicable objective (optional)	M Plan Apo, M Plan Apo SL, G Plan Apo: <b>378-320, 378-322, 378-324, 378-326</b> BD Plan Apo, BD Plan Apo SL: <b>378-321, 378-323, 378-325, 378-327</b>
Dimensions	Main unit	360 x 803 x 568.5mm	
	Workstage	700 x 400mm	
Power supply	100 to 240VAC, 50/60Hz		
Power consumption	Approx. 150W: <b>378-320, 378-321, 378-324, 378-325</b>		
	Approx. 300W: <b>378-322, 378-323, 378-326, 378-327</b>		
Mass	Approx. 50kg including workstage		

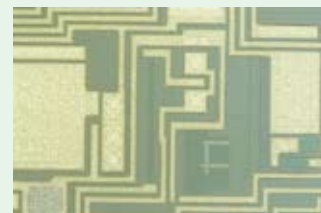

**Polarized light observation:**  
Observing only the filtered light that vibrates in one direction. Used for observing materials with special optical characteristics, such as mineral and liquid crystal.

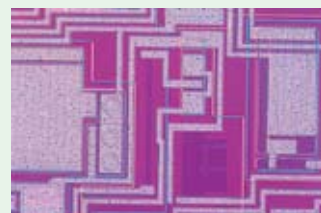

**Differential interference observation:**  
Effective in detecting fine scratches and steps on the surface of metal, liquid crystal, and semiconductors.

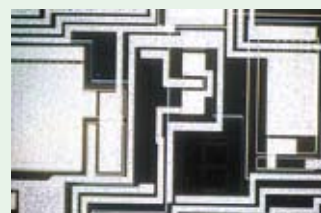

**Dark field observation:**  
Observing only the scattered light by shutting down the direct light to the objectives. The scratches and dust that cannot be viewed in the bright view field can be observed by this method in high-contrast.



**Bright field observation:**  
Most common method of observation. Observing directly the light reflected from the surface of the workpiece..



Refer to the FS300 leaflet (E4197) for more details.

# FS-70

## SERIES 378 — Microscope Unit for Semiconductor Inspection

### Technical Data

Focus adjustment	With concentric coarse and fine focusing wheels (right and left)
• Method:	50mm travel range
• Range:	0.1mm/rev. for fine adjustment, 3.8mm/rev. for coarse adjustment
Trinocular tube Image:	Erect image
Pupil distance:	Siedentopf type, adjustment range: 51 - 76mm
Field number:	24
Tilt angle:	0° - 20° (only -TH, -THS models)
Illumination system:	Reflective illumination for bright field (Koehler illumination, with aperture diaphragm)
Light source:	12V100W fiber-optics, non-stepped adjustment, light guide length 1.5m, power consumption 150W
Objectives (optional):	M Plan Apo, M Plan Apo SL, G Plan Apo

### FEATURES

- The optical system that was originally developed for the best-selling FS60 models was further enhanced for the FS70 models. It is ideal as the microscope unit of a prober station for semiconductors. (All models CE marked.)
- The FS70L supports three types of YAG laser wavelength ranges (1064nm, 532nm and 355nm), while the FS70L4 supports two types of wavelength ranges (532nm and 266nm), thus expanding the scope of laser applications, allowing laser-cutting of thin-films used in semiconductors and liquid crystal substrates. However, Mitutoyo assumes no responsibility whatever for the performance and/or safety of the laser system used with Mitutoyo microscopes. A careful examination is recommended in selecting a laser-emission unit.
- Bright field, Differential Interference Contrast (DIC) and polarized observations are standard with the FS70Z. The FS70L and FS70L4 do not support the DIC method.
- By employing an inward turret, the long working distance objectives provide excellent operability.
- An ergonomic design with superb operability: the FS70 employs the erect-image optical system (the image in the field of view has the same orientation as the specimen) and enlarged fine focus adjustment wheel with rubber grip coarse-adjustment knob.



### SPECIFICATIONS

Model No.	FS70	FS70-TH	FS70Z	FS70Z-TH	FS70L	FS70L-TH	FS70L4	FS70L4-TH
<b>Order No.</b>	<b>378-184-1</b>	<b>378-184-3</b>	<b>378-185-1</b>	<b>378-185-3</b>	<b>378-186-1</b>	<b>378-186-3</b>	<b>378-187-1</b>	<b>378-187-3</b>
Short base model No.	FS70-S	FS70-THS	FS70Z-S	FS70Z-THS	FS70L-S	FS70L-THS	FS70L4-S	FS70L4-THS
<b>Order No.</b>	<b>378-184-2</b>	<b>378-184-4</b>	<b>378-185-2</b>	<b>378-185-4</b>	<b>378-186-2</b>	<b>378-186-4</b>	<b>378-187-2</b>	<b>378-187-4</b>
Focus adjustment	50mm travel range with concentric coarse (3.8mm/rev) and fine (0.1mm/rev) focusing wheels (right / left)							
Image	Erect image							
Pupil distance	Siedentopf type, adjustment range: 51 - 76mm							
Field number	24							
Tilt angle	—	0° - 20°	—	0° - 20°	—	0° - 20°	—	0° - 20°
Optical pass ratio	50/50	100/0 or 0/100	50/50	100/0 or 0/100	100/0 or 0/100		100/0 or 0/100	
Protective filter	—		—		Built-in laser beam filter		Built-in laser beam filter	
Tube lens	1X		1X - 2X zoom		1X		1X	
Applicable laser	—		—		1064/532/355nm		532/266nm	
Camera mount	C-mount (using optional adapter B)				Use a laser with TV port.		C-mount receptacle (with green filter switch)	
Illumination system, optional	Reflective illumination for bright field (Koehler illumination, with aperture diaphragm) 12V 100W fiber-optics, non-stepped adjustment, light guide length: 1.5m, power consumption 150W							
Objective, optional (for observation)	M Plan Apo, M Plan Apo SL, G Plan Apo							
Objective, optional (for laser-cutting)	—				M/LCD Plan NIR, M/LCD Plan NUV		M Plan UV	
Loading*	14.5kg	13.6kg	14.1kg	13.2kg	14.2kg	13.5kg	13.9kg	13.1kg
Mass (main unit)	6.1kg	7.1kg	6.6kg	7.5kg	6.4kg	7.2kg	6.7kg	7.5kg

\*Loading on optical tube excluding weight of objective lenses and eyepieces



Refer to the Microscope Units leaflet (E4191) for more details.

# VMU

## SERIES 378 — Video Microscope Unit

The VMU is a compact, lightweight, and easy-to-install microscope unit for CCD camera monitoring in semiconductor fabrication facilities.

### FEATURES

- The optical system features ultra-long working distance objectives and correction for the wide range of radiation wavelengths in use.
- The fiber-optic reflected illumination keeps the workpiece free from thermal expansion. The fiber-optic illuminator is required for the light source.
- Also available with a laser mount or turret (objective mount).



### SPECIFICATIONS

Magnification of tube	1X
Applicable wavelength	378-505, 378-506 378-513 378-514
	Near-infrared and visible radiation Near-infrared—visible—near-ultraviolet radiation Visible and ultraviolet radiation
Objective	(Optional)
Reflected illumination	<ul style="list-style-type: none"> <li>• Telecentric system with aperture stop system</li> <li>• Fiber-optic illuminator (optional) is required.</li> </ul>
Light source	Halogen bulb (21V, 150W) (optional)
Mass	378-505: 570g 378-506: 590g 378-513: 1270g 378-514: 1300g

### Selection Guide to System Configuration

Order No. (Depends on each system configuration)	378-505	378-506	378-513	378-514
Vertical CCD camera mount	●	●	●	●
Horizontal CCD camera mount (Optional)		●		
YAG laser mount			●	●
Fiber-optic illumination unit			●	●
M Plan Apo, M Plan Apo SL, G Plan Apo objectives for bright field observation	▲	▲	▲	▲
M Plan Apo NIR, LCD Plan Apo NIR, M Plan Apo NUV and LCD Plan Apo NUV objectives for laser cutting				▲
M Plan UV objectives for laser machining				▲

●: Provided, ▲: Available as optional accessory

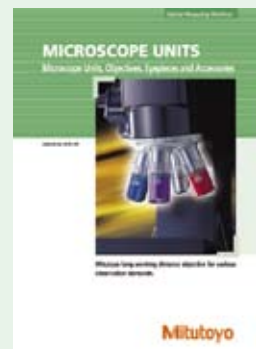

Refer to the Microscope Units leaflet (E4191) for more details.

# Eyepieces

## SERIES 378

### FEATURES

- The field of view is extra wide.
- Optional reticles are available.

#### Reticles (optional)

- 516848:** Cross-hair
- 516576:** Broken cross hair (90° and 60°)
- 516578:** Concentric circle  
(Diametric increment: 1.2mm)
- 516577:** 20mm scale  
(Minimum reading: 0.1mm) with cross hair
- 516849:** 10mm scale (Minimum reading: 0.1mm)
- 516850:** 5mm scale (Minimum reading: 0.05mm)
- 516851:** 10x10mm section  
(Minimum section: 1x1mm)



### SPECIFICATIONS

Order No. (2pcs. set)	Magnification	Field number	Mass	Individual order No.
<b>378-856</b>	10X	24	85g	<b>378-856-5</b>
<b>378-857</b>	15X	16	40g	<b>378-857-5</b>
<b>378-858</b>	20X	12	55g	<b>378-858-8</b>

# Objectives

## SERIES 378

The Mitutoyo 378 Series objectives have the world's longest working distance and an infinity correction optical system. These objectives provide flexible observation at high magnifications and independent correction of chromatic aberration.

### FEATURES

- The long working distance type objectives provide excellent clearance between the lens surface and the workpiece surface in focus, making it possible to observe workpieces which are usually hard-to-focus because of awkward projections.

- The metallurgical plan apochromatic (M Plan Apo) objective is an excellent optical system. This objective provides a flat, chromatic aberration-free image throughout the field of view, making it is suitable for any type of microscope.
- Specially designed objectives are also available with correction for near-infrared radiation, near-ultraviolet radiation, and ultraviolet radiation, or various thicknesses of LCD screen glasses.
- The mounting screw threads of objectives are designed to conform to JIS B-7141-1988.



Refer to the Microscope Units leaflet (E4191) for more details.



M Plan Apo and M Plan Apo SL objectives for bright field observation



BD Plan Apo and BD Plan Apo SL objectives for bright/dark field observation



Near-infrared radiation corrected M Plan Apo NIR objectives



Near-ultraviolet radiation corrected M Plan Apo NUV objectives



Ultraviolet radiation corrected M Plan UV objectives

### M Plan Apo for Bright Field Observation

Order No.	Mag.	N.A.	W.D.	f	R	D.F.	View field 1	View field 2	Mass
378-800-3	1X	0.025	11.0mm	200mm	11.0 $\mu$ m	440 $\mu$ m	$\varnothing$ 24mm	4.8x6.4mm	300g
378-801-6	2X	0.055	34.0mm	100mm	5.0 $\mu$ m	91 $\mu$ m	$\varnothing$ 12mm	2.4x3.2mm	220g
378-802-6	5X	0.14	34.0mm	40mm	2.0 $\mu$ m	14.0 $\mu$ m	$\varnothing$ 4.8mm	0.96x1.28mm	240g
378-807-3	7.5X	0.21	35.0mm	26.67mm	1.3 $\mu$ m	6.2 $\mu$ m	$\varnothing$ 3.6mm	0.64x0.85mm	240g
378-803-3	10X	0.28	33.5mm	20mm	1.0 $\mu$ m	3.5 $\mu$ m	$\varnothing$ 2.4mm	0.48x0.64mm	230g
378-804-3	20X	0.42	20.0mm	10mm	0.7 $\mu$ m	1.6 $\mu$ m	$\varnothing$ 1.2mm	0.24x0.32mm	270g
378-805-3	50X	0.55	13.0mm	4mm	0.5 $\mu$ m	0.9 $\mu$ m	$\varnothing$ 0.48mm	0.10x0.13mm	290g
378-806-3	100X	0.70	6.0mm	2mm	0.4 $\mu$ m	0.6 $\mu$ m	$\varnothing$ 0.24mm	0.05x0.06mm	320g

Note:  
Polarizing unit (378-074) is required when using 1X objective.

### DIMENSIONS

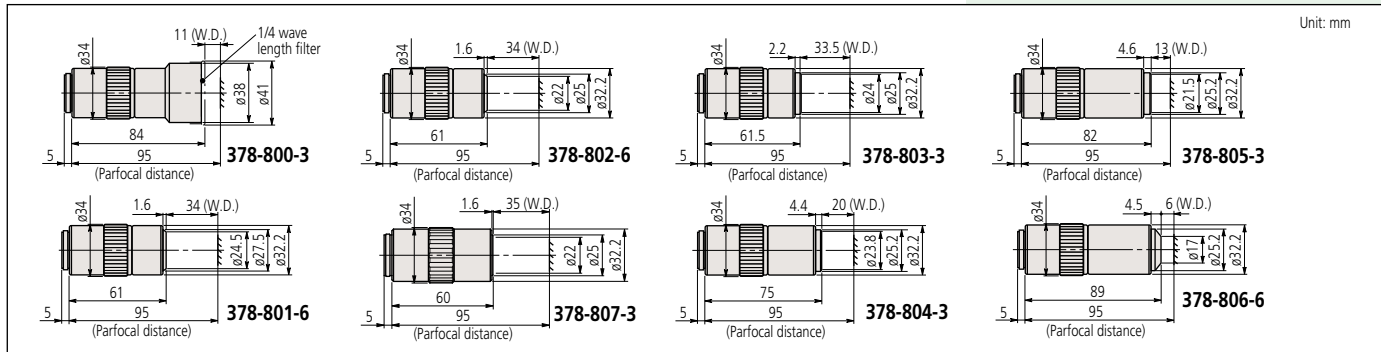

### M Plan Apo SL for Bright Field Observation

Order No.	Mag.	N.A.	W.D.	f	R	D.F.	View field 1	View field 2	Mass
378-810-3	20X	0.28	30.5mm	10mm	1.0 $\mu$ m	3.5 $\mu$ m	$\varnothing$ 1.2mm	0.24x0.32mm	240g
378-811-3	50X	0.42	20.5mm	4mm	0.7 $\mu$ m	1.6 $\mu$ m	$\varnothing$ 0.48mm	0.10x0.13mm	280g
378-812-3	80X	0.50	15.0mm	2.5mm	0.6 $\mu$ m	1.1 $\mu$ m	$\varnothing$ 0.3mm	0.06x0.08mm	280g
378-813-3	100X	0.55	13.0mm	2mm	0.5 $\mu$ m	0.9 $\mu$ m	$\varnothing$ 0.24mm	0.05x0.06mm	290g
378-816-3	200X	0.62	13.0mm	1mm	0.4 $\mu$ m	0.7 $\mu$ m	$\varnothing$ 0.12mm	0.025x0.03mm	490g

Note:  
These objectives offer extra-long working distance.

### DIMENSIONS

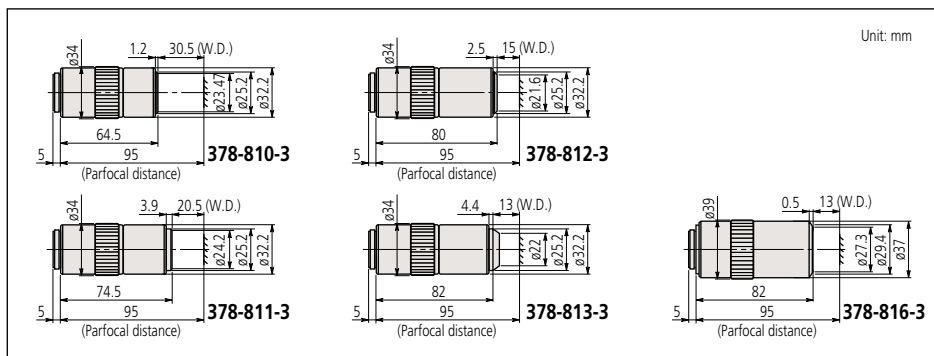

### M Plan Apo HR for Bright Field Observation

Order No.	Mag.	N.A.	W.D.	f	R	D.F.	View field 1	View field 2	Mass
378-788-4	10X	0.42	15mm	20mm	0.7 $\mu$ m	1.6 $\mu$ m	$\varnothing$ 2.4mm	0.48x0.64mm	460g
378-814-4	50X	0.75	5.2mm	4mm	0.4 $\mu$ m	0.49 $\mu$ m	$\varnothing$ 0.48mm	0.10x0.13mm	400g
378-815-4	100X	0.90	1.3mm	2mm	0.3 $\mu$ m	0.34 $\mu$ m	$\varnothing$ 0.24mm	0.05x0.06mm	410g

Note:  
These objectives offer extra-high resolving power.

### DIMENSIONS

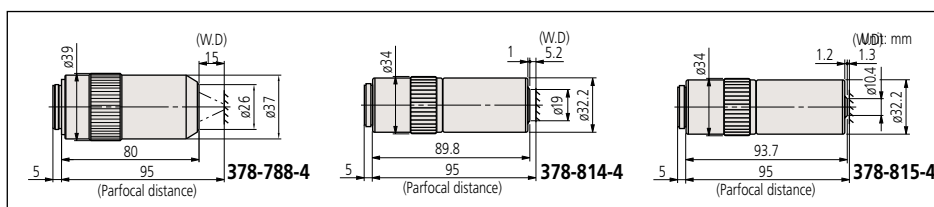

Mag.: Magnification  
N.A.: Numerical aperture  
W.D.: Working distance  
f: Focal distance  
R: Resolving power  
D.F.: Focal depth  
View field 1: Field of view when using  $\varnothing$ 24mm eyepiece  
View field 2: Field of view when using 1/2" CCD camera

Note:  
The G Plan Apo Series are designed for observing a  
workpiece through glass (thickness = 3.5mm).

### Glass Thickness (t = 3.5mm) Corrected G Plan Apo for Bright Field Observation

Order No.	Mag.	N.A.	W.D.	f	R	D.F.	View field 1	View field 2	Mass
<b>378-847</b>	20X	0.28	29.42mm*	10mm	1.0μm	3.5μm	ø1.2mm	0.24x0.32mm	270g
<b>378-848-3</b>	50X	0.50	13.89mm*	4mm	0.6μm	1.1μm	ø0.48mm	0.10x0.13mm	320g

\*In air

### DIMENSIONS

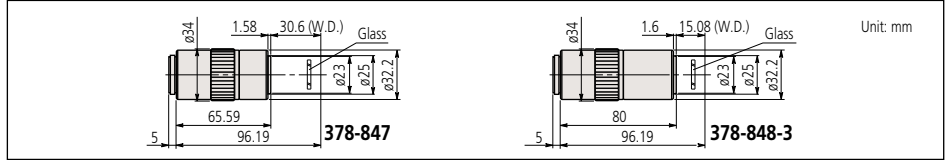

### BD Plan Apo for Bright/Dark Field Observation

Order No.	Mag.	N.A.	W.D.	f	R	D.F.	View field 1	View field 2	Mass
<b>378-831-7</b>	2X	0.055	34.0mm	100mm	5.0μm	91μm	ø12mm	2.4x3.2mm	340g
<b>378-832-7</b>	5X	0.14	34.0mm	40mm	2.0μm	14.0μm	ø4.8mm	0.96x1.28mm	350g
<b>378-830-7</b>	7.5X	0.21	34.0mm	26.67mm	1.3μm	6.2μm	ø3.6mm	0.64x0.85mm	350g
<b>378-833-7</b>	10X	0.28	34.0mm	20mm	1.0μm	3.5μm	ø2.4mm	0.48x0.64mm	350g
<b>378-834-7</b>	20X	0.42	20.0mm	10mm	0.7μm	1.6μm	ø1.2mm	0.24x0.32mm	400g
<b>378-835-7</b>	50X	0.55	13.0mm	4mm	0.5μm	0.9μm	ø0.48mm	0.10x0.13mm	440g
<b>378-836-7</b>	100X	0.70	6.0mm	2mm	0.4μm	0.6μm	ø0.24mm	0.05x0.06mm	460g

### DIMENSIONS

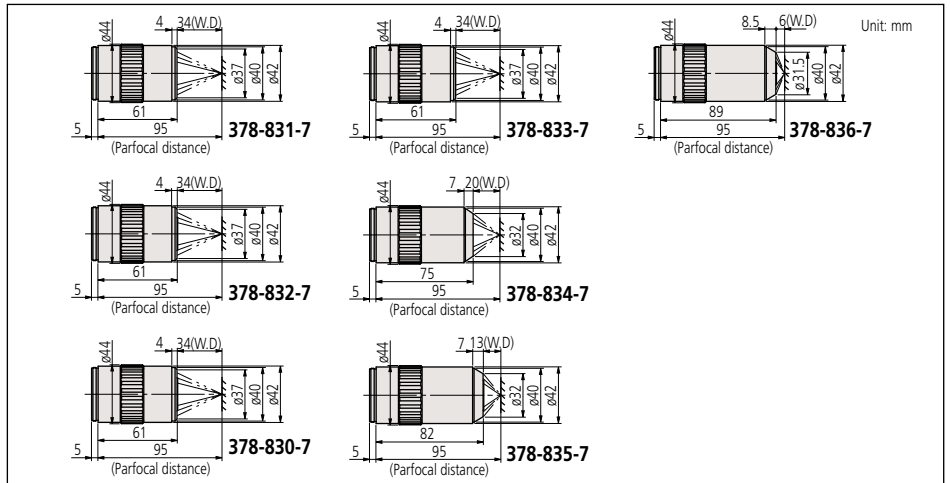

Note:  
These objectives offer extra-long working distance.

### BD Plan Apo SL for Bright/Dark Field Observation

Order No.	Mag.	N.A.	W.D.	f	R	D.F.	View field 1	View field 2	Mass
<b>378-840-7</b>	20X	0.28	30.5mm	10mm	1.0μm	3.5μm	ø1.2mm	0.24x0.32mm	350g
<b>378-841-7</b>	50X	0.42	20.0mm	4mm	0.7μm	1.6μm	ø0.48mm	0.10x0.13mm	410g
<b>378-842-7</b>	80X	0.50	13.0mm	2.5mm	0.6μm	1.1μm	ø0.3mm	0.06x0.08mm	430g
<b>378-843-7</b>	100X	0.55	13.0mm	2mm	0.5μm	0.9μm	ø0.24mm	0.05x0.06mm	440g

### DIMENSIONS

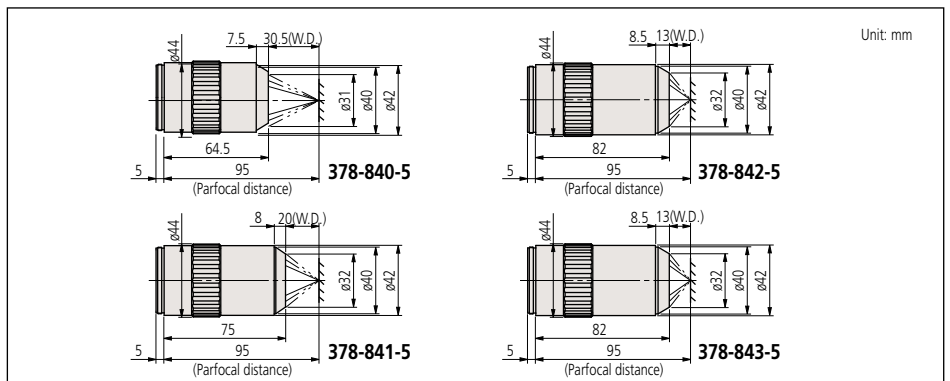

Mag.: Magnification  
N.A.: Numerical aperture  
W.D.: Working distance  
f: Focal distance  
R: Resolving power  
D.F.: Focal depth  
View field 1: Field of view when using ø24mm eyepiece  
View field 2: Field of view when using 1/2" CCD camera

### BD Plan Apo HR for Bright/Dark Field Observation

Order No.	Mag.	N.A.	W.D.	f	R	D.F.	View field 1	View field 2	Mass
378-845-7	50X	0.75	5.2mm	4mm	0.4 $\mu$ m	0.49 $\mu$ m	$\varnothing$ 0.48mm	0.10x0.13mm	530g
378-846-7	100X	0.90	1.3mm	2mm	0.3 $\mu$ m	0.34 $\mu$ m	$\varnothing$ 0.24mm	0.05x0.06mm	545g

Note:  
These objectives offer extra-high resolving power.

### DIMENSIONS

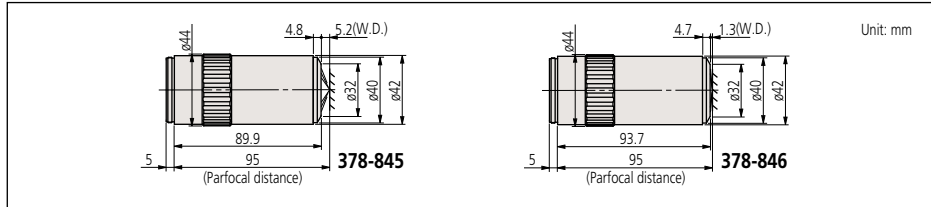

### Near-infrared Radiation Corrected M Plan Apo NIR for Bright Field Observation

Order No.	Mag.	N.A.	W.D.	f	R	D.F.	View field 1	View field 2	Mass
378-822-5	5X	0.14	37.5mm	40mm	2.0 $\mu$ m	14.0 $\mu$ m	$\varnothing$ 4.8mm	0.96x1.28mm	220g
378-823-5	10X	0.26	30.5mm	20mm	1.1 $\mu$ m	4.1 $\mu$ m	$\varnothing$ 2.4mm	0.48x0.64mm	250g
378-824-5	20X	0.40	20.0mm	10mm	0.7 $\mu$ m	1.7 $\mu$ m	$\varnothing$ 1.2mm	0.24x0.32mm	300g
378-825-5	50X	0.42	17.0mm	4mm	0.7 $\mu$ m	1.6 $\mu$ m	$\varnothing$ 0.48mm	0.10x0.13mm	315g
378-826-5	100X	0.50	12.0mm	2mm	0.6 $\mu$ m	1.1 $\mu$ m	$\varnothing$ 0.24mm	0.05x0.06mm	335g
378-863-5	50X	0.65	10mm	4mm	0.42 $\mu$ m	0.65 $\mu$ m	$\varnothing$ 0.48mm	0.10x0.13mm	450g
378-864-5	100X	0.70	10mm	2mm	0.39 $\mu$ m	0.56 $\mu$ m	$\varnothing$ 0.24mm	0.05x0.06mm	450g

Note:  
These objectives are designed so that a workpiece's image can be focused within the focal depth even when the wavelength used is changed anywhere from the visible range ( $\lambda = 480\text{nm}$ ) up to near-infrared range ( $\lambda = 1800\text{nm}$ ). Therefore the M Plan NIR Series are suitable for laser repair. However, when the wavelength used exceeds 1100nm, the focussing position may slightly deviate from that in the visible range due to changes in glass dispersion and refractive index.

### DIMENSIONS

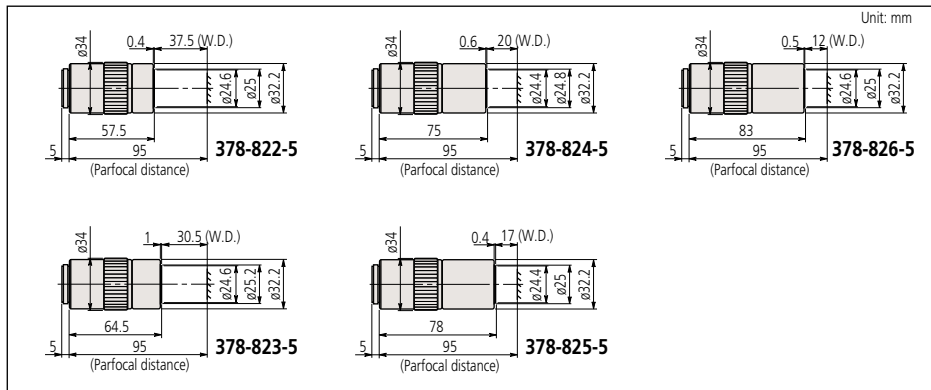

### Near-ultraviolet Radiation Corrected M Plan Apo NUV for Bright Field Observation

Order No.	Mag.	N.A.	W.D.	f	R	D.F.	View field 1	View field 2	-
378-809-5	10X	0.28	30.5mm	20mm	1 $\mu$ m	3.5 $\mu$ m	$\varnothing$ 2.4mm	0.48x0.64mm	255g
378-817-4	20X	0.40	17.0mm	10mm	0.7 $\mu$ m	1.7 $\mu$ m	$\varnothing$ 1.2mm	0.24x0.32mm	340g
378-818-4	50X	0.42	15.0mm	4mm	0.7 $\mu$ m	1.6 $\mu$ m	$\varnothing$ 0.48mm	0.10x0.13mm	350g
378-819-4	100X	0.50	11.0mm	2mm	0.6 $\mu$ m	1.1 $\mu$ m	$\varnothing$ 0.24mm	0.05x0.06mm	380g
378-888-4	50X	0.65	10.00mm	4mm	0.42 $\mu$ m	0.65 $\mu$ m	$\varnothing$ 0.48mm	0.10x0.13mm	500g

Note:  
These objectives are designed so that a workpiece's image can be focused within the focal depth even when the wavelength used is changed anywhere from the visible range ( $\lambda = 620\text{nm}$ ) to the near-ultraviolet range ( $\lambda = 355\text{nm}$ ). Therefore The M Plan NUV Series are suitable for laser repair using a high frequency laser beam.

### DIMENSIONS

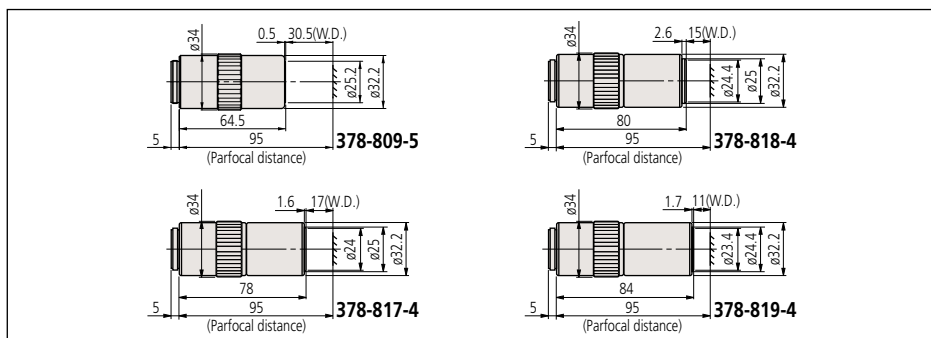

Mag.: Magnification  
N.A.: Numerical aperture  
W.D.: Working distance  
f: Focal distance  
R: Resolving power  
D.F.: Focal depth  
View field 1: Field of view when using  $\varnothing$ 24mm eyepiece  
View field 2: Field of view when using 1/2" CCD camera

Note:  
These near-infrared ( $\lambda = 1800\text{nm}$ ) corrected objectives are designed for observing a workpiece through LCD glass (thickness = 1.1mm (378-827-4, 378-828-5) or 0.7mm (378-829-5, 378-754-5)) and for laser repair.

### Near-Infrared Radiation and LCD Glass Thickness ( $t = 1.1\text{mm}$ or $0.7\text{mm}$ ) Corrected LCD Plan Apo NIR for Bright Field Observation

Order No.	Mag.	N.A.	W.D.	f	R	D.F.	View field 1	View field 2	Mass
378-827-5	20X	0.40	19.98mm*	10mm	0.7 $\mu\text{m}$	1.7 $\mu\text{m}$	$\varnothing 1.2\text{mm}$	0.24x0.32mm	305g
378-828-5	50X	0.42	17.13mm*	3.9mm	0.7 $\mu\text{m}$	1.6 $\mu\text{m}$	$\varnothing 0.48\text{mm}$	0.10x0.13mm	320g
378-829-5	50X	0.42	17.26mm*	3.9mm	0.7 $\mu\text{m}$	1.6 $\mu\text{m}$	$\varnothing 0.48\text{mm}$	0.10x0.13mm	320g
378-752-5	100X	0.50	12.13mm*	2mm	0.6 $\mu\text{m}$	1.1 $\mu\text{m}$	$\varnothing 0.24\text{mm}$	0.05x0.06mm	335g
378-754-5	100X	0.50	11.76mm*	2mm	0.6 $\mu\text{m}$	1.1 $\mu\text{m}$	$\varnothing 0.24\text{mm}$	0.05x0.06mm	335g

\*In air

### DIMENSIONS

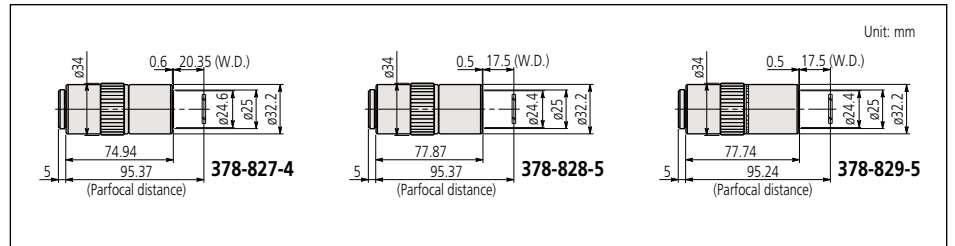

Note:  
These near-infrared ( $\lambda = 1800\text{nm}$ ) corrected objectives are designed for observing a workpiece through LCD glass (thickness = 1.1mm (378-827-4, 378-828-5) or 0.7mm (378-829-5, 378-754-5)) and for laser repair.

### Near-ultraviolet Radiation and LCD Glass Thickness ( $t = 0.7\text{mm}$ ) Corrected LCD Plan Apo NUV for Bright Field Observation

Order No.	Mag.	N.A.	W.D.	f	R	D.F.	View field 1	View field 2	Mass
378-820-4	50X	0.42	14.76mm*	4mm	0.7 $\mu\text{m}$	1.6 $\mu\text{m}$	$\varnothing 0.48\text{mm}$	0.10x0.13mm	310g
378-753-4	50X	0.42	14.53mm	4mm	0.7 $\mu\text{m}$	1.6 $\mu\text{m}$	$\varnothing 0.48\text{mm}$	0.10x0.13mm	310g
378-751-4	100X	0.50	11.03mm	2mm	0.6 $\mu\text{m}$	1.1 $\mu\text{m}$	$\varnothing 0.24\text{mm}$	0.05x0.06mm	380g

\*In air

### DIMENSIONS

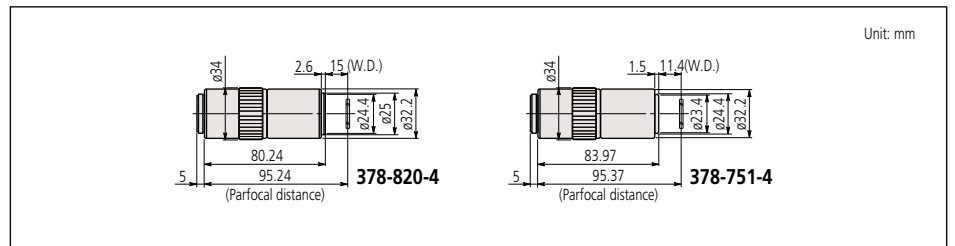

Note:  
These ultraviolet corrected objectives are designed so that a workpiece's image can be focused within the focal depth even when the wavelength used is changed anywhere from the visible range ( $\lambda = 550\text{nm}$ ) to the ultraviolet range ( $\lambda = 266\text{nm}$ ). Therefore the M Plan UV Series are suitable for laser repair using a high frequency laser beam.

### Ultraviolet Radiation Corrected M Plan UV for Bright Field Observation

Order No.	Mag.	N.A.	W.D.	f	R	D.F.	View field 1	View field 2	Mass
378-844-5	10X	0.25	20mm	20mm	1.1 $\mu\text{m}$	4.4 $\mu\text{m}$	$\varnothing 2.4\text{mm}$	0.48x0.64mm	310g
378-837-5	20X	0.36	15.0mm	10mm	0.8 $\mu\text{m}$	2.1 $\mu\text{m}$	$\varnothing 1.2\text{mm}$	0.24x0.32mm	330g
378-838-5	50X	0.40	12.0mm	4mm	0.7 $\mu\text{m}$	1.7 $\mu\text{m}$	$\varnothing 0.48\text{mm}$	0.10x0.13mm	400g
378-839-5	80X	0.55	10.0mm	2.5mm	0.5 $\mu\text{m}$	0.9 $\mu\text{m}$	$\varnothing 0.3\text{mm}$	0.06x0.08mm	380g

### DIMENSIONS

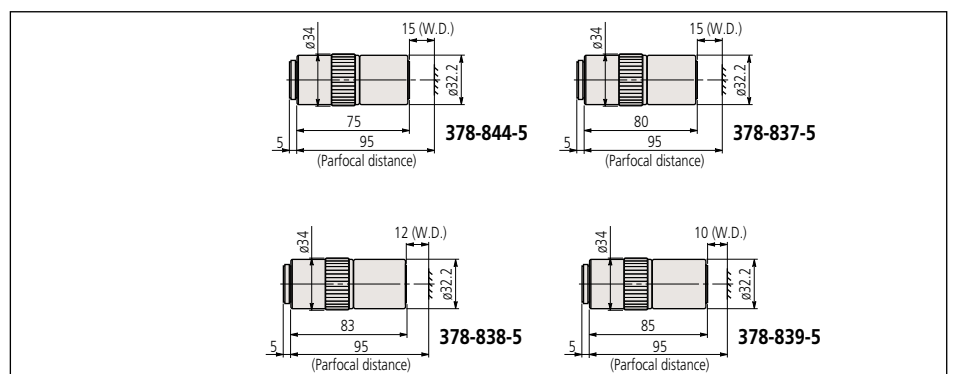

Mag.: Magnification  
N.A.: Numerical aperture  
W.D.: Working distance  
f: Focal distance  
R: Resolving power  
D.F.: Focal depth  
View field 1: Field of view when using  $\varnothing 24\text{mm}$  eyepiece  
View field 2: Field of view when using 1/2" CCD camera

# MSM-400

## SERIES 377 — Stereo Microscopes

### FEATURES

- Bright, sharp images with real depth are produced with high resolution and excellent faithfulness to color, thus minimizing eye fatigue while increasing inspection efficiency and productivity.
- The MSM series provides a full range of advanced functions at an affordable price.
- User-friendly turret types (MSM-412, MSM-465) and a zoom type (MSM-Z414) are available.
- Continuous zooming, a standard feature, allows you to enlarge the object by 10 to 40 times in total magnification.
- MSM series can be connected to a digital camera or CCD camera to save captured images of the object or for simultaneous observation through different media.
- The extended depth of focus, long working distance and wide field of view increase work efficiency. The system is ideal for inspecting various objects such as electronic components, metal components, plants, mineral compositions and biological cells.
- Various attachments expand applications and use. Extended MSM units can be used for appearance inspections, on processing lines, inside inspection systems or in teaching environments.



MSM-412



MSM-Z414



MSM-Z475T



MSM-465

### SPECIFICATIONS

Model No.	MSM-412	MSM-Z414	MSM-Z475	MSM-Z475T	MSM-465
<b>Order No.</b>	<b>377-925</b>	<b>377-945*</b>	<b>377-975*</b>	<b>377-985*</b>	<b>377-965*</b>
Optical system	Greenough's type				Galilean type
Total magnification	10X, 20X	10X to 40X	7.5X to 50X		6X, 12X, 25X, 50X
Optical tub	Binocular	Binocular	Binocular	Trinocular	Binocular
Pupil distance (adjustable)	54 - 76mm	54 - 76mm	52 - 79mm		54 - 76mm
Eyepiece (optional)	WF5X/22, WF10X/20 (standard), WF15X/13, WF20X/10	WF5X/22, WF10X/20 (standard), WF15X/13, WF20X/10	WF10X/23 (standard), WF5X/23, WF6.25X/23, WF15X/17, WF20X/13, WF32X/8		WF6.25X/23, WF10X/23 (standard), WF15X/17.6, WF20X/13.4, WF32X/10
Objective	1X, 2X (turret)	1X to 4X (zoom)	0.75X to 5X (zoom)		1.2X, 2.5X, 5X (turret)
Auxiliary objective (optional)	—	0.5X, 0.75X, 1.5X	0.5X, 0.63X, 1.5X, 2X		0.6X, 1.2X, 2.5X, 5X
Total magnification	2.5X to 60X	2.5X to 120X	1.87X to 320X		3.75X to 320X
Working distance of objective	95mm	80mm	113mm		89mm
Focusing travel	44mm	44mm	50mm		50mm
Maximum workpiece height	93mm	95mm	130mm		95mm*
Workstage size	ø95mm	ø95mm	ø95mm		ø95mm
Dimensions	151x285x343mm	151x285x343mm	151x285x343mm		151x285x343mm
Mass	4.9kg ( <b>377-925B</b> ) 4.7kg	5.3kg ( <b>377-945B</b> ) 5.1kg	5.3kg	5.4kg	4.8kg ( <b>377-965B</b> ) 6.3kg

\* To denote your AC power cable add the following suffixes to the order No.: **A** for UL/CSA, **C** for Taiwan, **D** for CEE, **DC** for CCC, **E** for BS, **K** for EK, **No suffix** is required for JIS/100V

**Optional Lenses**  
For MSM-412, Z414



5X/22 eyepiece:  
377-026



15X/13 eyepiece:  
377-028



20X/10 eyepiece:  
377-029



0.5X Auxiliary objective  
377-045



0.75X Auxiliary objective  
377-046



1.5X Auxiliary objective  
377-047

**For MSM-465**



6.25X/23 eyepiece:  
377-066



15X/17.6 eyepiece:  
377-067



20X/13.4 eyepiece:  
377-068



32X/10 eyepiece:  
377-069



0.5X Auxiliary objective  
377-076



1.5X Auxiliary objective  
377-077



2X Auxiliary objective  
377-078

**DIMENSIONS**

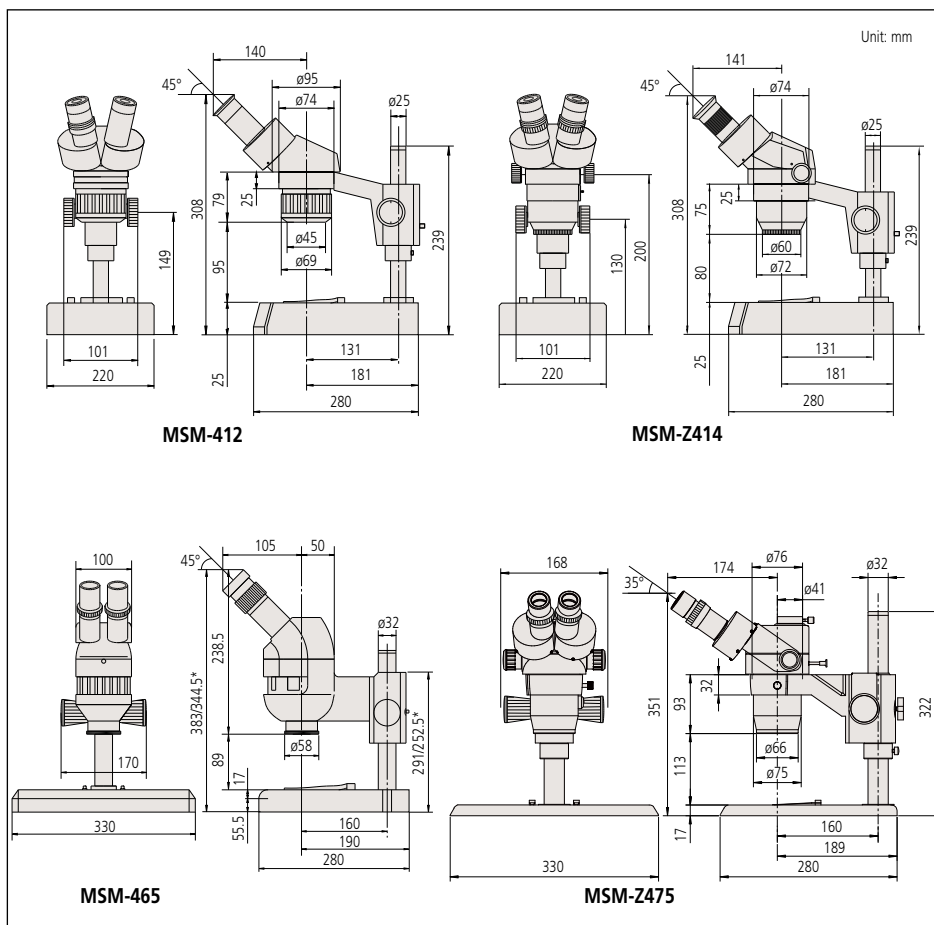

**MSM-465**



**MSM-Z414**



# Pocket Magnifiers

## SERIES 183

### FEATURES

- Suitable for inspecting metal surfaces.

### SPECIFICATIONS

Magnification	Order No.	Remarks
25X	183-201	Pen type
	183-202	With stand
50X	183-203	With stand



183-201



183-202



183-203

### Optional Reticles for pocket comparators



183-102

183-103

183-104



183-105

183-106

183-107



183-108

183-109

183-110

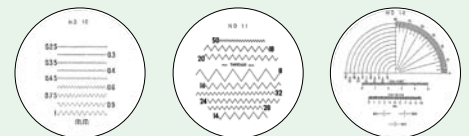

183-111

183-112

183-113



183-114

183-115

# Pocket Comparators

## SERIES 183

### FEATURES

- By replacing optional reticles, dimensional, angle, and other types of measurement can be performed.
- An optional illuminator (950757) is available.

### SPECIFICATIONS

Magnification	Order No.	Remarks
8X	183-101	Optional reticles available
9X	183-121	Optional reticles available
10X	183-131	Optional reticles available



183-101

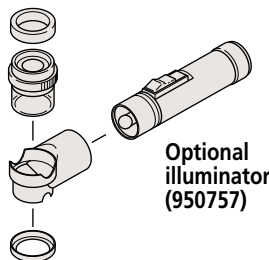

Optional illuminator (950757)

# Zoom loupe

## SERIES 183

### FEATURES

- Allows the user 8X - 16X zoom observation.
- Magnification indicator is provided for 8X, 10X, 12X, 14X, and 16X observation.
- Metric and inch scales are provided for measuring.
- Comes with a carrying case.



183-304

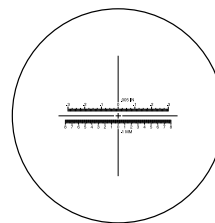

Reticle provided

### SPECIFICATIONS

Magnification	Order No.	Remarks
8X	183-304	With reticles (Scale graduation: 0.1mm, .005")

# Clear Loupe

## SERIES 183



183-301

183-302

183-303

### SPECIFICATIONS

Magnification	Order No.	Remarks
7X	183-301	Drawtube removable
10X	183-302	Drawtube removable
15X	183-303	Drawtube removable