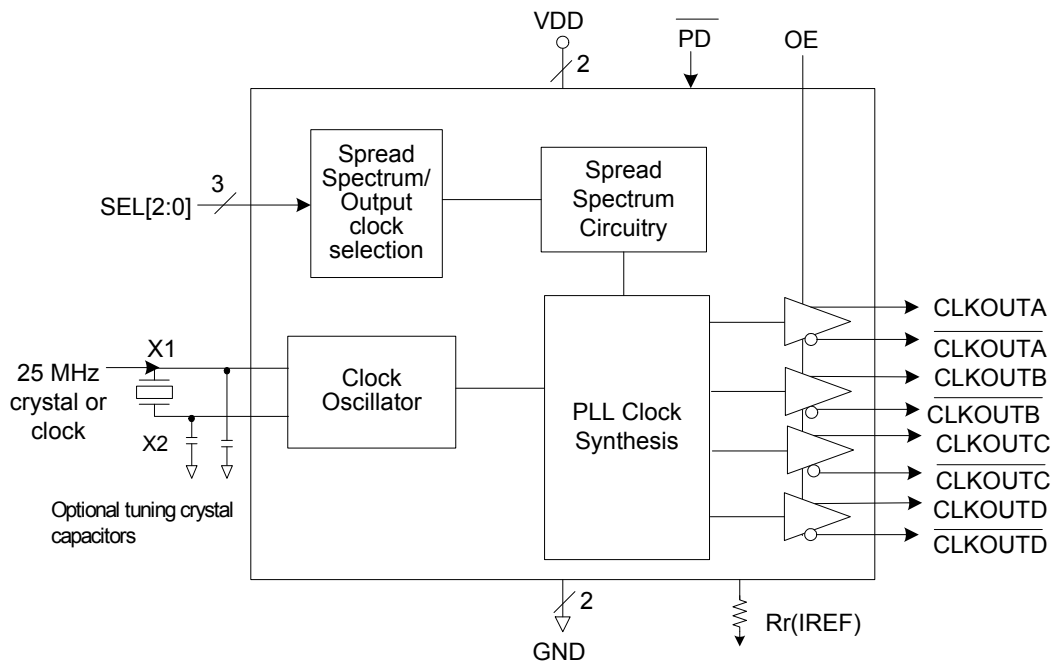

**QUAD DIFFERENTIAL PCI-EXPRESS CLOCK SOURCE**
**ICS557-05A**
**Description**

The ICS557-05A is a spread-spectrum clock generator that supports PCI-Express requirements. It is used in PC or embedded systems to substantially reduce electro-magnetic interference (EMI). The device provides four differential HCSL or LVDS high-frequency outputs with spread spectrum capability. The output frequency and spread type are selectable using external pins.

**Features**

- Packaged in 20-pin TSSOP
- RoHS 5 (green) or RoHS 6 (green and lead free) complaint package
- Supports PCI-Express applications
- Four differential spread spectrum clock outputs
- Spread spectrum for EMI reduction
- Uses external 25 MHz clock or crystal input
- Power down pin turns off chip
- OE control tri-states outputs
- Spread and frequency selection via external pins
- Spread Bypass option available
- Industrial temperature range available

**Block Diagram**

## Pin Assignment

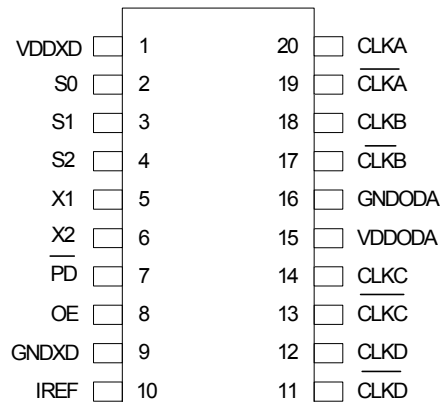

20-pin (173 mil) TSSOP

## Spread Spectrum Selection Table

S2	S1	S0	Spread%	Spread Type	Output Frequency
0	0	0	-0.5	Down	100
0	0	1	-1.0	Down	100
0	1	0	-1.5	Down	100
0	1	1	No Spread	Not Applicable	100
1	0	0	-0.5	Down	200
1	0	1	-1.0	Down	200
1	1	0	-1.5	Down	200
1	1	1	No Spread	Not Applicable	200

## Pin Descriptions

Pin	Pin Name	Pin Type	Pin Description
1	VDDXD	Power	Connect to +3.3 V digital supply.
2	S0	Input	Spread spectrum select pin #0. See table above. Internal pull-up resistor.
3	S1	Input	Spread spectrum select pin #1. See table above. Internal pull-up resistor.
4	S2	Input	Spread spectrum select pin #2. See table above. Internal pull-up resistor.
5	X1	Input	Crystal connection. Connect to a fundamental mode crystal or clock input.
6	X2	Output	Crystal connection. Connect to a fundamental mode crystal or leave open.
7	PD	Input	Powers down all PLL's and tri-states outputs when low. Internal pull-up resistor.
8	OE	Input	Provides output on, tri-states output (High = enable outputs; Low = disable outputs). Internal pull-up resistor.
9	GND	Power	Connect to digital ground.
10	IREF	Output	Precision resistor attached to this pin is connected to the internal current reference.
11	CLKD	Output	Selectable 100/200 MHz spread spectrum differential Compliment output clock D.
12	CLKD	Output	Selectable 100/200 MHz spread spectrum differential True output clock D.
13	CLKC	Output	Selectable 100/200 MHz spread spectrum differential Compliment output clock C.
14	CLKC	Output	Selectable 100/200 MHz spread spectrum differential True output clock C.
15	VDDODA	Power	Connect to +3.3 V analog supply.
16	GND	Power	Connect to analog ground.
17	CLKB	Output	Selectable 100/200 MHz spread spectrum differential Compliment output clock B.
18	CLKB	Output	Selectable 100/200 MHz spread spectrum differential True output clock B.
19	CLKA	Output	Selectable 100/200 MHz spread spectrum differential Compliment output clock A.
20	CLKA	Output	Selectable 100/200 MHz spread spectrum differential True output clock A.

## Application Information

### Decoupling Capacitors

As with any high-performance mixed-signal IC, the ICS557-05A must be isolated from system power supply noise to perform optimally.

Decoupling capacitors of 0.01 $\mu$ F must be connected between each VDD and the PCB ground plane.

### PCB Layout Recommendations

For optimum device performance and lowest output phase noise, the following guidelines should be observed.

Each 0.01 $\mu$ F decoupling capacitor should be mounted on the component side of the board as close to the VDD pin as possible. No vias should be used between decoupling capacitor and VDD pin. The PCB trace to VDD pin should be kept as short as possible, as should the PCB trace to the ground via. Distance of the ferrite bead and bulk decoupling from the device is less critical.

2) An optimum layout is one with all components on the same side of the board, minimizing vias through other signal layers (the ferrite bead and bulk decoupling capacitor can be mounted on the back). Other signal traces should be routed away from the ICS557-05A.

This includes signal traces just underneath the device, or on layers adjacent to the ground plane layer used by the device.

### External Components

A minimum number of external components are required for proper operation. Decoupling capacitors of 0.01  $\mu$ F should be connected between VDD and GND pairs (1,9 and 15,16) as close to the device as possible.

**On chip capacitors-** Crystal capacitors should be connected from pins X1 to ground and X2 to ground to optimize the initial accuracy. The value (in pf) of these crystal caps equal  $(C_L - 12) * 2$  in this equation,  $C_L$  = crystal load capacitance in pf. For example, for a crystal with a 16 pF load cap, each external crystal cap would be 8 pF.  $[(16 - 12) * 2] = 8$ .

### Current Reference Source $R_r$ ( $I_{ref}$ )

If board target trace impedance (Z) is 50 $\Omega$ , then  $R_r = 475\Omega$  (1%), providing IREF of 2.32 mA, output current ( $I_{OH}$ ) is equal to 6\*IREF.

### Load Resistors $R_L$

Since the clock outputs are open source outputs, 50 ohm external resistors to ground are to be connected at each clock output.

### Output Termination

The PCI-Express differential clock outputs of the ICS557-05A are open source drivers and require an external series resistor and a resistor to ground. These resistor values and their allowable locations are shown in detail in the **PCI-Express Layout Guidelines** section.

The ICS557-05A can also be configured for LVDS compatible voltage levels. See the **LVDS Compatible Layout Guidelines** section.

## Output Structures

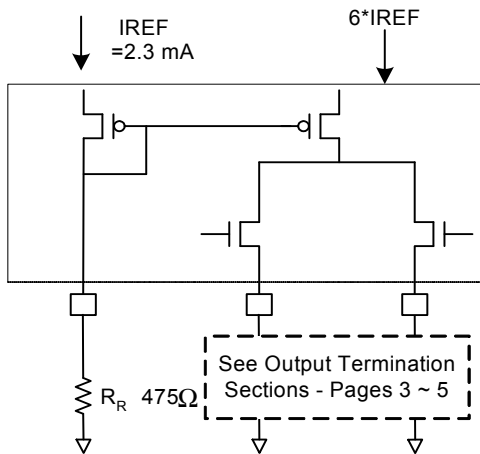

## General PCB Layout Recommendations

For optimum device performance and lowest output phase noise, the following guidelines should be observed.

1. Each  $0.01 \mu\text{F}$  decoupling capacitor should be mounted on the component side of the board as close to the VDD pin as possible.
2. No vias should be used between decoupling capacitor and VDD pin.
3. The PCB trace to VDD pin should be kept as short as possible, as should the PCB trace to the ground via. Distance of the ferrite bead and bulk decoupling from the device is less critical.
4. An optimum layout is one with all components on the same side of the board, minimizing vias through other signal layers (any ferrite beads and bulk decoupling capacitors can be mounted on the back). Other signal traces should be routed away from the ICS557-05A. This includes signal traces just underneath the device, or on layers adjacent to the ground plane layer used by the device.

## PCI-Express Layout Guidelines

Common Recommendations for Differential Routing	Dimension or Value	Unit
L1 length, Route as non-coupled 50 ohm trace.	0.5 max	inch
L2 length, Route as non-coupled 50 ohm trace.	0.2 max	inch
L3 length, Route as non-coupled 50 ohm trace.	0.2 max	inch
$R_S$	33	ohm
$R_T$	49.9	ohm

Differential Routing on a Single PCB	Dimension or Value	Unit
L4 length, Route as coupled <b>microstrip</b> 100 ohm differential trace.	2 min to 16 max	inch
L4 length, Route as coupled <b>stripline</b> 100 ohm differential trace.	1.8 min to 14.4 max	inch

Differential Routing to a PCI Express Connector	Dimension or Value	Unit
L4 length, Route as coupled <b>microstrip</b> 100 ohm differential trace.	0.25 to 14 max	inch
L4 length, Route as coupled <b>stripline</b> 100 ohm differential trace.	0.225 min to 12.6 max	inch

## PCI-Express Device Routing

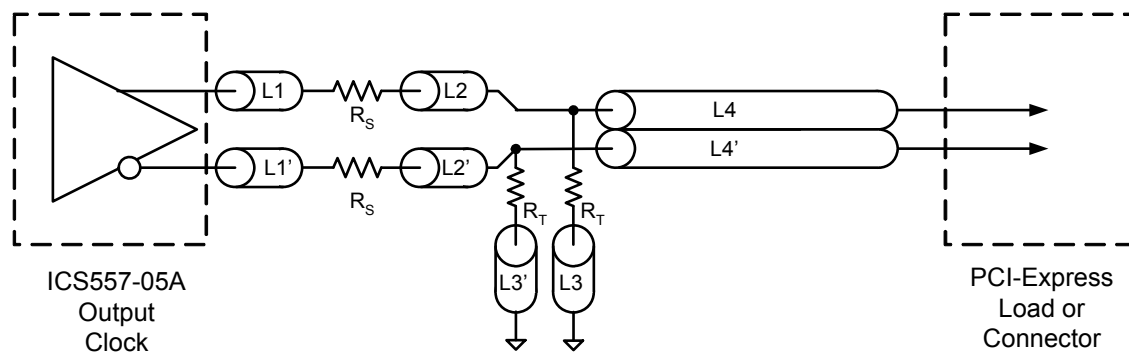

## Typical PCI-Express (HCSL) Waveform

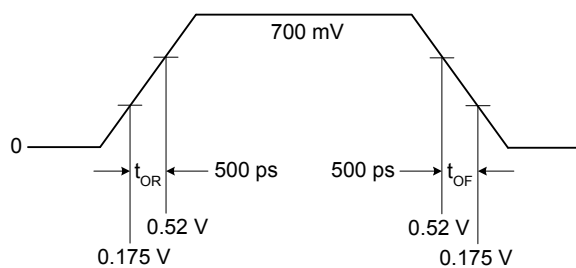

## LVDS Compatible Layout Guidelines

Alternative Termination for LVDS and other Common Differential Signals							
V <sub>diff</sub>	V <sub>p-p</sub>	V <sub>cm</sub>	R1	R2	R3	R4	Note
0.45v	0.22v	1.08	33	150	100	100	
0.58	0.28	0.6	33	78.7	137	100	
0.80	0.40	0.6	33	78.7	none	100	ICS874003i-02 input compatible
0.60	0.3	1.2	33	174	140	100	Standard LVDS

R1a = R1b = R1

R2a = R2b = R2

## LVDS Device Routing

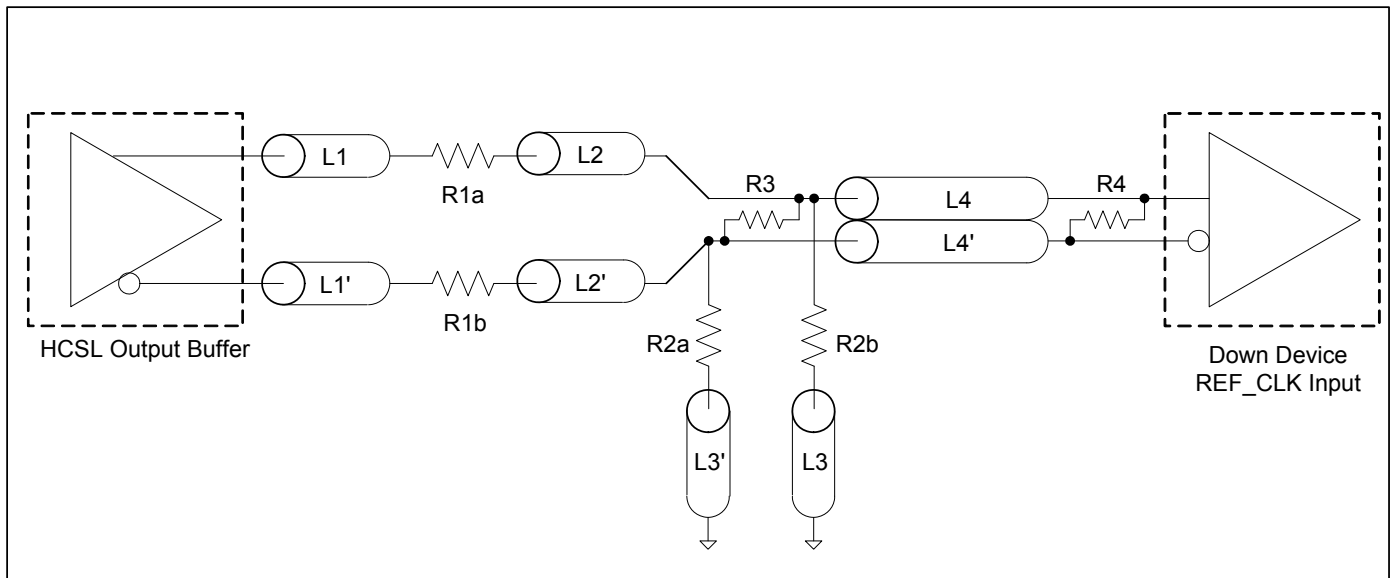

## Typical LVDS Waveform

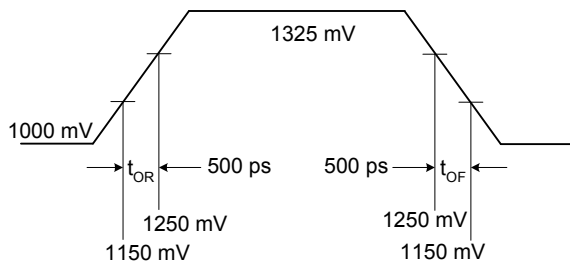

## Absolute Maximum Ratings

Stresses above the ratings listed below can cause permanent damage to the ICS557-05A. These ratings are stress ratings only. Functional operation of the device at these or any other conditions above those indicated in the operational sections of the specifications is not implied. Exposure to absolute maximum rating conditions for extended periods can affect product reliability. Electrical parameters are guaranteed only over the recommended operating temperature range.

Item	Rating
Supply Voltage, VDD, VDDA	5.5 V
All Inputs and Outputs	-0.5 V to VDD+0.5 V
Ambient Operating Temperature (commercial)	0 to +70° C
Ambient Operating Temperature (industrial)	-40 to +85° C
Storage Temperature	-65 to +150° C
Junction Temperature	125° C
Soldering Temperature	260° C
ESD Protection (Input)	2000 V min. (HBM)

## DC Electrical Characteristics

Unless stated otherwise, VDD = 3.3 V ±5%, Ambient Temperature -40 to +85° C

Parameter	Symbol	Conditions	Min.	Typ.	Max.	Units
Supply Voltage	V		3.135		3.465	
Input High Voltage <sup>1</sup>	V <sub>IH</sub>		2.0		VDD +0.3	V
Input Low Voltage <sup>1</sup>	V <sub>IL</sub>		VSS-0.3		0.8	V
Input Leakage Current <sup>2</sup>	I <sub>IL</sub>	0 < V <sub>in</sub> < VDD	-5		5	μA
Operating Supply Current	I <sub>DD</sub>	50Ω, 2 pF load @ 100 MHz		105		mA
	I <sub>DDOE</sub>	OE =Low		40		mA
	I <sub>DDPD</sub>	No load, $\overline{PD}$ =Low		500		μA
Input Capacitance	C <sub>IN</sub>	Input pin capacitance			7	pF
Output Capacitance	C <sub>OUT</sub>	Output pin capacitance			6	pF
Pin Inductance	L <sub>PIN</sub>				5	nH
Output Resistance	R <sub>out</sub>	CLK outputs	3.0			kΩ
Pull-up Resistance	R <sub>PUP</sub>	OE, SEL, $\overline{PD}$ pins		110		kΩ

1. Single edge is monotonic when transitioning through region.

2. Inputs with pull-ups/-downs are not included.

## AC Electrical Characteristics - CLKOUTA/CLKOUTB, HCSL

Unless stated otherwise, VDD=3.3 V  $\pm$ 5%, Ambient Temperature -40 to +85° C

Parameter	Symbol	Conditions	Min.	Typ.	Max.	Units
Input Frequency				25		MHz
Output Frequency		HCSL termination			200	MHz
Output High Voltage <sup>1,2</sup>	V <sub>OH</sub>		660	700	850	mV
Output Low Voltage <sup>1,2</sup>	V <sub>OL</sub>		-150	0	27	mV
Crossing Point Voltage <sup>1,2</sup>		Absolute	250	350	550	mV
Crossing Point Voltage <sup>1,2,4</sup>		Variation over all edges			140	mV
Jitter, Cycle-to-Cycle <sup>1,3</sup>					80	ps
Modulation Frequency		Spread spectrum	30	31.5	33	kHz
Rise Time <sup>1,2</sup>	t <sub>OR</sub>	From 0.175 V to 0.525 V	175	332	700	ps
Fall Time <sup>1,2</sup>	t <sub>OF</sub>	From 0.525 V to 0.175 V	175	344	700	ps
Skew between outputs		At crossing point Voltage			50	ps
Duty Cycle <sup>1,3</sup>			45		55	%
Output Enable Time <sup>5</sup>		All outputs			10	us
Output Disable Time <sup>5</sup>		All outputs			10	us
Power-up Time	t <sub>STABLE</sub>	From power-up VDD=3.3 V		3.0		ms
Spread Change Time	t <sub>SPREAD</sub>	Settling period after spread change		3.0		ms

<sup>1</sup> Test setup is R<sub>L</sub>=50 ohms with 2 pF, R<sub>r</sub> = 475Ω (1%).

<sup>2</sup> Measurement taken from a single-ended waveform.

<sup>3</sup> Measurement taken from a differential waveform.

<sup>4</sup> Measured at the crossing point where instantaneous voltages of both CLKOUT and  $\overline{\text{CLKOUT}}$  are equal.

<sup>5</sup> CLKOUT pins are tri-stated when OE is asserted low. CLKOUT is driven differential when OE is high unless its  $\overline{\text{PD}}$ = low.

## AC Electrical Characteristics - CLKOUTA/CLKOUTB, LVDS

Unless stated otherwise, VDD=3.3 V ±5%, Ambient Temperature -40 to +85° C

Parameter	Symbol	Conditions	Min.	Typ.	Max.	Units
Input Frequency				25		MHz
Output Frequency		LVDS termination			100	MHz
Differential Output Voltage	V <sub>OD</sub>		247		454	mV
Offset Voltage	V <sub>OS</sub>		1.125		1.375	V
ΔV <sub>OD</sub>		Change to V <sub>OD</sub>			50	mV
ΔV <sub>OS</sub>		Change to V <sub>OS</sub>			50	mV
Jitter, Cycle-to-Cycle <sup>1,3</sup>					80	ps
Modulation Frequency		Spread spectrum	30	31.5	33	kHz
Slew Rate, Rise <sup>1,3</sup>	t <sub>SLR</sub>	Measured from ±150 mV from crossing point voltage	1		4	V/ns
Slew Rate, Fall <sup>1,3</sup>	t <sub>SLF</sub>	Measured from ±150 mV from crossing point voltage	1		4	V/ns
Skew between outputs		At crossing point Voltage			50	ps
Duty Cycle <sup>1,3</sup>			45		55	%
Output Enable Time <sup>5</sup>		All outputs			10	μs
Output Disable Time <sup>5</sup>		All outputs			10	μs
Power-up Time	t <sub>STABLE</sub>	From power-up VDD=3.3 V		3		ms
Spread Change Time	t <sub>SPREAD</sub>	Settling period after spread change		3		ms

<sup>1</sup> Test setup is R<sub>L</sub>=50 ohms with 2 pF, R<sub>r</sub> = 475Ω (1%).

<sup>2</sup> Measurement taken from a single-ended waveform.

<sup>3</sup> Measurement taken from a differential waveform.

<sup>4</sup> Measured at the crossing point where instantaneous voltages of both CLKOUT and  $\overline{\text{CLKOUT}}$  are equal.

<sup>5</sup> CLKOUT pins are tri-stated when OE is asserted low. CLKOUT is driven differential when OE is high unless its  $\overline{\text{PD}}$ = low.

## Thermal Characteristics

Parameter	Symbol	Conditions	Min.	Typ.	Max.	Units
Thermal Resistance Junction to Ambient	θ <sub>JA</sub>	Still air		93		°C/W
	θ <sub>JA</sub>	1 m/s air flow		78		°C/W
	θ <sub>JA</sub>	3 m/s air flow		65		°C/W
Thermal Resistance Junction to Case	θ <sub>JC</sub>			20		°C/W

## Package Outline and Package Dimensions (20-pin TSSOP, 173 mil Body)

Package dimensions are kept current with JEDEC Publication No. 95, MO-153

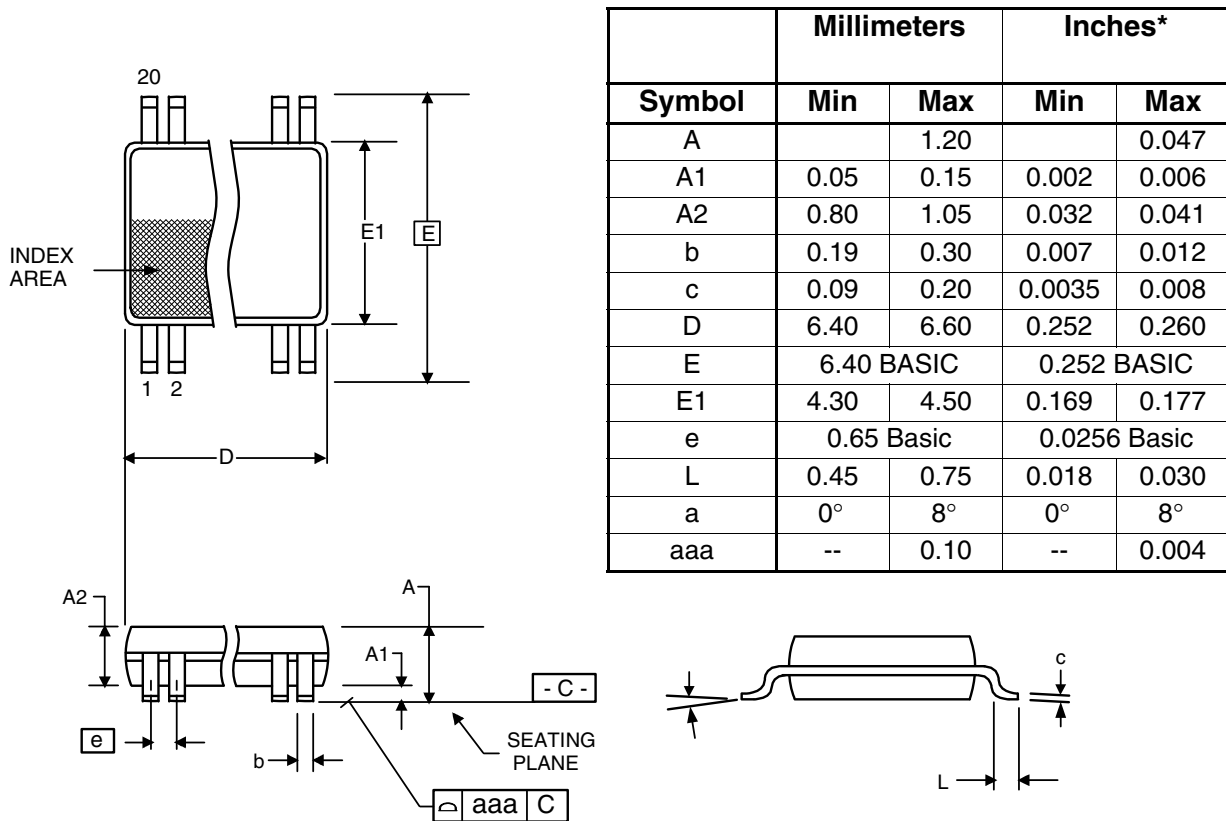

## Ordering Information

Part / Order Number	Marking	Shipping Packaging	Package	Temperature
557G-05ALF	557G-05ALF	Tubes	20-pin TSSOP	0 to +70° C
557G-05ALFT	557G-05ALF	Tape and Reel	20-pin TSSOP	0 to +70° C
557GI-05ALF	557GI-05AL	Tubes	20-pin TSSOP	-40 to +85° C
557GI-05ALFT	557GI-05AL	Tape and Reel	20-pin TSSOP	-40 to +85° C

“LF” suffix to the part number are the Pb-Free configuration, RoHS compliant.

While the information presented herein has been checked for both accuracy and reliability, Integrated Device Technology (IDT) assumes no responsibility for either its use or for the infringement of any patents or other rights of third parties, which would result from its use. No other circuits, patents, or licenses are implied. This product is intended for use in normal commercial applications. Any other applications such as those requiring extended temperature range, high reliability, or other extraordinary environmental requirements are not recommended without additional processing by IDT. IDT reserves the right to change any circuitry or specifications without notice. IDT does not authorize or warrant any IDT product for use in life support devices or critical medical instruments.

**Innovate with IDT and accelerate your future networks. Contact:**

[www.IDT.com](http://www.IDT.com)

**For Sales**

800-345-7015  
408-284-8200  
Fax: 408-284-2775

**For Tech Support**

[www.idt.com/go/clockhelp](http://www.idt.com/go/clockhelp)

---

**Corporate Headquarters**

Integrated Device Technology, Inc.  
[www.idt.com](http://www.idt.com)

