



Operating Instructions

Electronic Tachometer Two limit values TA134

Contents

Page

1	Safety indications.....	2
2	Get to know your TA134	3
2.1	TA134 components	4
2.2	Block diagram of the TA134	4
3	TA134 connection	5
3.1	Supply voltage connection.....	6
3.2	Assignment of signal outputs „Relay contacts“	6
3.3	Assignment of signal outputs „electronic“	7
3.4	Assignment of signal inputs.....	7
3.4.1	Examples of connection.....	7
3.5	Encoder supply connection.....	8
3.6	Interface connection	8
4	TA134 operation	9
5	TA134 programming	11
6	Technical data	17
6.1	Dimensions and cutout measures	17
7	Model / Ordering data	18

General information

Please find below the explanation to the symbols used in the following operating instructions.

Explanation of symbols

- ➔ This symbol induces actions.
- This symbol refers to additional technical information.



This symbol is placed in front of text passages that have to be particularly observed to ensure the correct use of the TA134.



This symbol is placed in front of text passages that supply further important information.

Italics

Important terms are written in *italics* on the left for quick reference purposes.

1 Safety indications

The tachometer has been designed to the latest state of the art.

Use the instrument only

- in an absolutely correct technical state,
- for the intended purpose,
- being conscious of relevant safety and danger, and observe the operating instructions.

Intended purpose

The instrument is to be used only indoors as built-in model for industrial processes and controls on production lines of the metal, wood, plastic, paper, glass and textile industries and similar; the overvoltage exerted on the terminals of the instrument must be limited to the voltages of category II. Description of the overvoltage category under DIN VDE 0110, Section 2. The instrument may only be operated in a correctly mounted state. The instrument may only be operated as described under chapter „Technical data“.



The instrument may not be used in hazardous areas, for medical apparatus, nor for applications expressly declared under EN 61 010.

If the instrument is to be used to control machines or processes, where the machine could be damaged or the operator could be injured due to a breakdown of the instrument or to a failure in operation, then relevant safety precautions will need to be taken.

Organizational measures

Make sure that your personnel has read and understood the operating instructions, especially the chapter "Safety indications".

In addition to the operating instructions, please make sure that generally applicable legal and other mandatory regulations relevant to accident prevention and environment protection are observed.

Be conscious of safety

In the event of safety-relevant modifications (including those in the behavior of the instrument during operation), immediately stop operation of instrument.



- Installation* The installation may only be effected as described under the chapter „Connection“.
During installation work, take care to cut off the power supply of the instrument. Installations may only be effected by a skilled expert.
Prior to initial operation of the instrument, please control the voltage selection. Set the switch to the required AC voltage.
During installation make sure that supply voltage and connection of the output contacts are provided from the same MAINS phase.
Max. voltage 250 V Terminal - Terminal, Earth - Terminal.
- Initial operation* The instrument is ready for use after it has been correctly mounted and installed.
- Maintenance / Servicing / Trouble shooting* Cut off power supply of all connected machinery.
These tasks may only be effected by a skilled expert. In case of unsuccessful trouble shooting, you must absolutely interrupt use of instrument and contact your dealer.
- Getting acquainted* After successful initial operation, get acquainted with the handling of your instrument by studying the chapter „Get to know your TA134“.

2 Get to know your TA134

2.1 TA134 components

It comprises

- a 6-digit tachometer with 2 limit values
- a 6-digit batch counter with scaling factor.

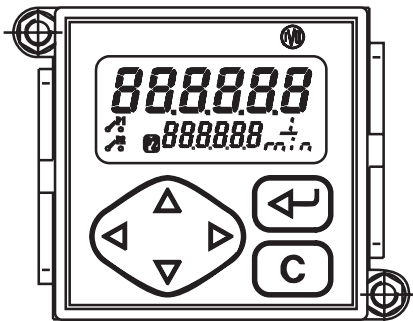

LCD-Display

Current tachometer display

P1 Limit value 1

P2 Limit value 2

Control state of limit value P1

Control state of limit value P2

b Batch counter

Measuring units: 1/h, 1/min, 1/s

Control panel



Shift key for display of functions, Confirmation key



Reset



Key to select HIGHER decades



Key to select decades to the RIGHT



Key to select decades to the LEFT



Key to select LOWER decades

2.2 Block diagram of the TA134

The block diagram shows the components of the TA134 together with its contacts and connections.

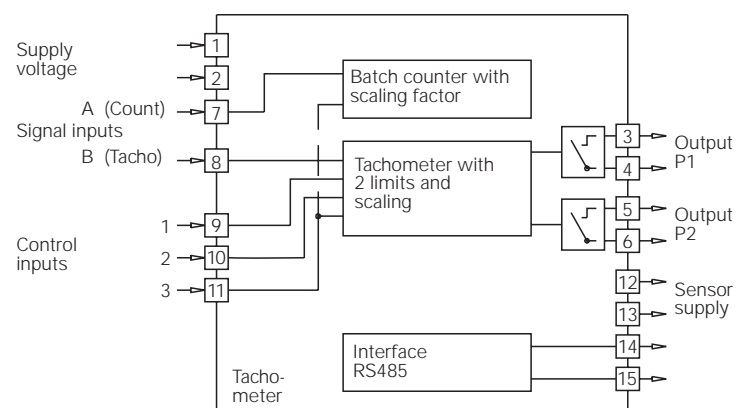

3 TA134 connection

This chapter will explain how the contacts are assigned and give you some examples of connection. Under chapters 3.1 to 3.6, you will find actual tips and technical data for the various connections.

Assignment Model with relay outputs

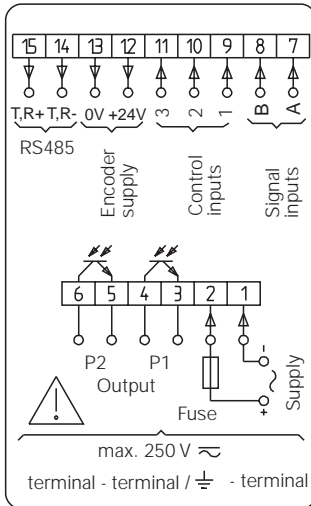

Contact Function

1	Supply voltage
2	Supply voltage
3	Relay output P1
4	Relay output P1
5	Relay output P2
6	Relay output P2
7	Signal input A (Count)
8	Signal input B (Tacho)
9	Control input 1 (Tacho Hold)
10	Control input 2 (Programming Disabled)
11	Control input 3 (Batch counter Reset)
12	Encoder supply +10 ... 26 V
13	Encoder supply 0 V
14	Option RS485 (T,R-)
15	Option RS485 (T,R+)

Assignment Model with electronic outputs

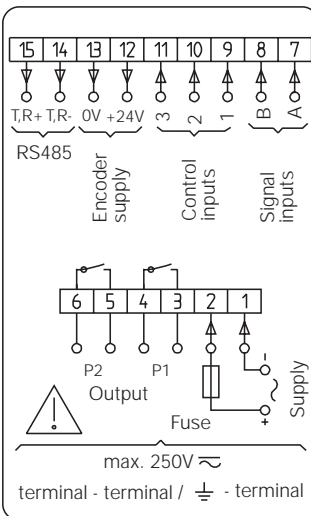

Contact Function

1	Supply voltage
2	Supply voltage
3	Output P1
4	Output P1
5	Output P2
6	Output P2
7	Signal input A (Count)
8	Signal input B (Tacho)
9	Control input 1 (Tacho Hold)
10	Control input 2 (Programming Disabled)
11	Control input 3 (Batch counter Reset)
12	Encoder supply +10 ... 26 V
13	Encoder supply 0 V
14	Option RS485 (T, R-)
15	Option RS485 (T, R+)



Litz contact only by means of connector sleeves with insulating enclosures for reasons of shock protection according to EN 61 010. Do not otherwise assign contacts that have been left unassigned ex factory. We recommend to screen all encoder terminal leads and to ground the shield on one side. Shields on both sides are recommended in case of RF interference or in case of equipotential bonding. The encoder leads should not be in the same phase winding as the MAINS supply and the output contact leads.

3.1 Supply voltage connection

AC connection It is possible to choose two different AC voltages by using the selector on the side. The respectively higher voltage (48 VAC or 230 VAC) is preset at the factory.

- ➔ Switch to the required AC voltage using the selector.
- ➔ Connect AC at the contacts 1 and 2 according to the TA134 terminal diagram.

Supply voltage	Recommended external protection
24 VAC ±10 % 50/60 Hz	M 400 mA
48 VAC ±10 % 50/60 Hz	M 200 mA
115 VAC ±10 % 50/60 Hz	M 100 mA
230 VAC ±10 % 50/60 Hz	M 50 mA

DC connection Connect interference-free supply voltage. Therefore, do not use the supply voltage for parallel supply of drives, contactors, electromagnetic valves, etc.
➔ Connect DC according to the TA134 terminal diagram.

Supply range: 12 ... 30 VDC ±10 %, max. 5 % residual ripple
Recommended external protection: M 400 mA



Fire protection: Operate instrument on the MAINS with external fuse recommended on the rating plate. In case of disturbance, make sure that 8 A /150 VA (W) are never exceeded – as defined under EN 61010.

3.2 Assignment of signal outputs „Relay contacts“

Contact P2

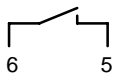

Contact P1

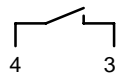

The signal outputs (contacts 3, 4 and 5, 6) are floating relay contacts. The signal outputs can be assigned as per the adjacent terminal diagram.

The switching function, as momentary or latched signal, can be chosen in the programming line 40.

Their function, as normally open or closed, is selected in programming line 40.

Max. rating	Max. voltage	Max. current
150 VA / 30 W	250 V	1 A



The user must take care that, in case of disturbance, the contact rating of 8 A / 150 VA (W) is not exceeded.

Internal spark suppression by means of zinc-oxide varistor (275 V).

The output relays of the instrument (1 relay or several) may in total **switch 5 x per minute at the most. Admissible clicks** according to interference suppression standard EN 55011, EN 50081-2 for the industrial sector. In case of higher switching rate, the operator will be responsible to take care of local interference suppression in consideration of the contact rating.

3.3 Assignment of signal outputs „electronic“

Output P2

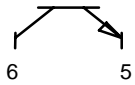

Output P1

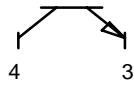

The electronic outputs (contacts 3, 4 and 5, 6) are optocoupler outputs. The signal outputs can be assigned as per the adjacent terminal diagram.

The switching function, as momentary or latched signal, can be chosen in the programming line 40.

Their function, as normally open or closed, is selected in programming line 40.

Max. voltage	Max. current	Max. residual voltage
+ 40 VDC	25 mA	at 25 mA < 1 V



The electronic outputs are not short-circuit-proof.

3.4 Assignment of signal inputs

Choice of PNP or NPN

The contacts 7 to 11 are comparator signal inputs.

They can be triggered either by PNP or NPN encoders. The input logic as well as the operating threshold are correspondingly chosen in programming line 33.

Contact 7 triggers the batch counter. The counting rate (3 Hz, 25 Hz or 10 kHz) is chosen in programming line 32. Contact 8 triggers the tachometer. The frequency range of 25 Hz or 40 kHz is determined on programming line 31.

The contacts 9, 10 and 11 are control inputs for Hold, Programming Disabled, Batch counter Reset, etc. The function of these control inputs is selected in the programming lines 34, 36 and 37.

The minimum pulse duration of control input 1 can be switched in programming line 35 from 30 ms to 100 µs.

For control inputs 2 and 3, 30 ms are generally valid.

Input resistance	Selectable operating threshold
ca. 3 kOhm	3 V and 6 V

3.4.1 Examples of connection

Encoder	TA134 contact assignment	Programming
Contact	8 Track B 12 + 24 V	Counting rate: Line 31 to 1 = 25 Hz
Proximity switch PNP or NPN	8 Track B 12 + 24 V 13 0 V	Input logic: Line 33 to 0 = PNP Line 33 to 1 = NPN
Namur without explosion protection	8 Track B 13 0 V	Input logic: Line 33 to 1 = NPN
Incremental encoder	7 8 Track B 12 + 24 V 13 0 V	Counting rate: Line 31 to 0 = 40 Hz

3.5 Encoder supply connection



Connect encoder supply for rotary encoder, proximity switch, etc. to the contacts 12 and 13. However, do not use encoder supply for unearthed inductors or capacitive loads.



The encoder supply is not short-circuit-proof.

Contact	Voltage	Max. admissible current
12	10 ... 26 VDC	60 mA
13	0 V	

3.6 Interface connection

The serial interface can perform the following functions:

- Retrieve data
- Program parameters.

Interface parameters are:

- Transmission speed (Baud rate),
- Parity bit,
- Number of stop bits,
- Address of controller for master.

The interface parameters can be set on the programming level (Lines 51 to 54).

RS 485

Half-duplex transmission with the following features:

- Symmetrical
- 2 lines
- Multi-point connection – emitter and receiver (max. 32 units)
- Maximum distance of data transmission: 1500 m

→ Assign contacts 14 (T,R-) and 15 (T,R+) accordingly.

4 TA134 operation

The following chapter will inform you on the operation of your TA 134.

- The TA134 is automatically on the operator level after the supply voltage has been turned on.

On the operator level it is possible

- to read the tachometer display;
- to read and, if necessary, modify the limit values P1 and P2;
- to read and, if necessary, modify the evaluation of the tachometer;
- to read and, if necessary clear the batch counter;
- to read and, if necessary, modify the scaling factor (batch counter).

- It is possible to disable all operator parameters on the programming level (Lines 11-17).

The keys and their function

Parameter reading Select the enabled parameters via the key ↑ or ↓.
The key ↵ allows to switch to the next operation parameter.
For quick sweep, keep this key depressed.

Resetting of batch counter 1. Display count.
2. Push C.

Setting of parameters 1. Display parameter.
2. Push ← or → and select required decade; chosen decade position blinks.
3. Push ↑ or ↓ and enter required value.
To set further decades, repeat steps 2 and 3.
4. Confirm the parameter entered with ↵.
Should no confirmation be given within 15 s, the previous setting will remain valid.

Tachometer display F

The upper display indicates the current tachometer value.
The lower display indicates limit value P2 or a parameter of your choice in programming line 27.

Read Read tachometer display F and, for example, limit value P2.

	0
P2	1000

	100
	P1

	1000
	P2

Limit value P1

Read Push ↓ or ↵.

The limit value P1 is displayed.
The lower display indicates „P1“.

Modify Enter limit value P1 via the keys ← → ↑ ↓.
Push ↵.

Limit value P2

Read Push ↓ or ↵.

The limit value P2 is displayed.
The lower display indicates „P2“.

Modify Enter limit value P2 via the keys ← → ↑ ↓.
Push ↵.

1.0000
BF

Evaluation bF

The evaluation digit (divisor) will help to adapt the display of the tachometer to the number of pulses per measuring unit.

Example for calculating the evaluation bF

Measure rotational speed 50 pulses per revolution are supplied when measuring rotational speed. The evaluation is then set to 50.

$$\text{Evaluation} = \text{Pulses/rev.} = 50$$

Measure speed When measuring speed with encoder and cyclometer, the circumference of the cyclometer measures 0.5 m, the encoder has a resolution of 50 pulses per revolution. The measurement is to be presented in m/min. The evaluation is then set to 100.

$$\text{Evaluation} = \frac{\text{Pulses/rev.}}{\text{Circumference}} = \frac{50}{0.5} = 100$$

1.0000
bF

Read Push ↓ or ↵.

The evaluation bF is displayed.
The lower display indicates „bF“.

Modify Enter the evaluation bF via the keys ← → ↑ ↓.
Push ↵.

Batch counter b

Read Push ↓ or ↵.

The batch counter b is displayed.
The lower display indicates „b“.

Clear Push C.

0
b

Scaling factor SF

The scaling factor (multiplier) allows the display of fractions or multiples of the impulses on the batch counter.

Setting range: 0.0001 to 9999.99. Setting ex factory to 1.0000.

Example While the tachometer is displaying the rotational speed, the number of revolutions is to be counted by the batch counter. An encoder with 2 pulses per revolution is used for this application.

The scaling factor is calculated as follows:

$$\text{Scaling factor} = \frac{1 \text{ rev.}}{\text{Pulses}} = \frac{1}{2} = 0.5$$

Read Push ↓ or ↵.

The scaling factor SF is displayed.
The lower display indicates „SF“.

Modify Enter the scaling factor via the keys ← → ↑ ↓.

The setting range from 0.0001 to 999.99 is attained by shifting the decimal point. Select the decimal point via ← and shift using ↑.

Push ↵.



By pushing ↓ or ↵ again, the current count is re-displayed.

5 TA134 programming

This chapter will inform you on how to program your TA134.

Programming level	Operation parameters are set on the programming level. The programming level consists of 3 programming fields. Access is protected by a 4-digit code or via a control input.
<i>1st programming field</i>	Here it is possible to select and modify all operation parameters. The operation parameters that are disabled for the operator are also displayed.
<i>2nd programming field</i>	The individual operation parameters for operator access are disabled or enabled here.
<i>3rd programming field</i>	All functions and values as well as interface parameters conditioned by the machinery are programmed here.

The keys and their function

<i>Turn on programming</i>	Push ↑ and ↓ simultaneously. „Code“ appears on the lower display.
----------------------------	--



No code number has yet been set at the factory, therefore it is possible to skip the code query by pushing ↓.

The code is set on programming line 50.

After a code has been set, it will only be possible to switch to the programming level by entering the correct code.

<i>Enter code</i>	Enter code via the keys ← → ↑ ↓. Push ↓ to confirm. The instrument switches from the operator level to the programming level.
<i>Wrong code</i>	If a wrong code has been entered, „Error“ is displayed as long as ↓ remains pushed. After 15 s the instrument switches automatically back to the operator level.
<i>Correct code unknown</i>	If the correct code is not known, please return the counter to the supplier or effect reset to factory setting.
<i>Select programming lines</i>	Select the programming line needed via the keys ↓ ↑. This function can also be reached by pushing ↓. The line number is displayed.
<i>Modify operation parameters</i>	Select the decade to be changed via the keys ← →. The selected decade blinks. Enter the value by pushing the keys ↑ ↓. Push ↓.
<i>Leave programming</i>	It is possible to shut down the programming at any time by pushing ↑ and ↓ simultaneously.
<i>Reset to factory setting</i>	Turn on instrument and press the keys ← and ↑ simultaneously. All values already programmed are set back to the factory setting. 'Clr Pro' appears on the display.



Programming field 1

Here it is possible to select and modify all operation parameters. The operation parameters that are disabled for the operator are also displayed.

Line 1

0
1 F

F – Tachometer display

Line 2

100
2 P1

P1 - Limit value 1

Line 3

1000
3 P2

P2 - Limit value 2

Line 4

0
4 bF

bF – Evaluation of tachometer

Line 6

0
6 b

b - Batch counter

Line 7

1.0000
7 SF

SF - Scaling factor

- - - - -

The dash line indicates the end of the first programming field. Switch to programming field 2 by pushing ↓ or ↵.

Programming field 2

The individual operation parameters for operator access are disabled or enabled here.

StAt appears on the upper display. The lower display indicates the line number and the abbreviation for the operation parameter. The status number is entered on the upper display.

Meaning of the status numbers

- 0 Free access** It is possible to select, read and modify the operation parameter on the operator level.
- 1 Display only** It is possible to select and read the operation parameter on the operator level.
- 2 Disabled** It is impossible to select the operation parameter on the operator level. Its corresponding function is however sustained.



Each factory setting is marked as such by *.

Modify status

Enter corresponding status number via the keys ← → ↑ ↓. Push ↵.

Line 11

StAt 1	
11	F

F – Tachometer display

- 0 Free access
- 1 * Display only
- 2 Disabled

Line 12

StAt 0	
12	P1

P1 - Limit value 1

- 0 * Free access
- 1 Display only
- 2 Disabled

Line 13

StAt 0	
13	P2

P2 - Limit value 2

- 0 * Free access
- 1 Display only
- 2 Disabled

Line 14

StAt 2	
14	bF

bF – Evaluation of tachometer

- 0 Free access
- 1 Display only
- 2 * Disabled

Line 16

StAt 2	
16	b

b - Batch counter

- 0 Free access
- 1 Display only
- 2 * Disabled

Line 17

StAt 2	
17	SF

SF - Scaling factor for batch counter

- 0 Free access
- 1 Display only
- 2 * Disabled

- - - - -

The dash line indicates the end of the second programming field. Switch to programming field 3 by pushing ↓ or ↵.

Programming field 3

All functions and values as well as interface parameters conditioned by the machinery are programmed here.



Each factory setting is marked as such by *.

Line 24

24	0
----	---

Decimal point for F, P1, P2

- 0 * No decimal point
- 1 00000.0
- 2 0000.00
- 3 000.000

Line 26

26	0
----	---

Indication of measuring unit on display

- 0 * without measuring unit
- 1 1/h
- 2 1/min
- 3 1/s

Line 27

27	2
----	---

Assignment of lower display

The upper display always indicates the current value.

- 0 without lower display
- 1 P1 - Limit value
- 2 * P2 - Limit value
- 3 bF - Evaluation of tachometer
- 4 b - Batch counter
- 5 SF - Scaling factor

Line 28

28	1
----	---

Update time (Repetition of display)

- 0 0.5 s
- 1 * 1 s
- 2 2 s
- 3 3 s
- 4 5 s
- 5 10 s
- 6 20 s
- 7 30 s
- 8 60 s

Line 29

29	0
----	---

Timeout (Tachometer)

- 0 * 1 s
- 1 2 s
- 2 3 s
- 3 5 s
- 4 10 s
- 5 20 s
- 6 30 s
- 7 60 s
- 8 Timeout not operating
- 9 Timeout not operating, last display value memorized after breakdown of current

Line 30

30	0
----	---

Time unit of tachometer

- 0 * 1/min
- 1 1/s
- 2 1/h

<i>Line 31</i>	<div style="float: right; font-size: 24px; font-weight: bold;">0</div> <div style="clear: both; text-align: center; font-size: 18px; font-weight: bold;">31</div>	<p>Frequency Track B for tachometer</p> <p>0 * 40 kHz 1 25 Hz</p>
<i>Line 32</i>	<div style="float: right; font-size: 24px; font-weight: bold;">0</div> <div style="clear: both; text-align: center; font-size: 18px; font-weight: bold;">32</div>	<p>Frequency Track A for batch counter</p> <p>0 * 10 kHz 1 25 Hz 2 3 Hz</p>
<i>Line 33</i>	<div style="float: right; font-size: 24px; font-weight: bold;">0</div> <div style="clear: both; text-align: center; font-size: 18px; font-weight: bold;">33</div>	<p>Input logic and Operating thresholds of signal inputs</p> <p>0 * PNP Operating threshold 6 V 1 NPN Operating threshold 6 V, or for Namur without explosion protection 2 PNP Operating threshold 3 V 3 NPN Operating threshold 3 V</p>
<i>Line 34</i>	<div style="float: right; font-size: 24px; font-weight: bold;">0</div> <div style="clear: both; text-align: center; font-size: 18px; font-weight: bold;">34</div>	<p>Function Control input 1 (Contact 9)</p> <p>0 * Hold for tachometer and batch counter 1 Programming disabled 2 Keylock 3 Print (principally, 30 ms minimum pulse duration)</p>
<i>Line 35</i>	<div style="float: right; font-size: 24px; font-weight: bold;">0</div> <div style="clear: both; text-align: center; font-size: 18px; font-weight: bold;">35</div>	<p>Minimum pulse duration for control input 1</p> <p>0 * 30 ms 1 100 µs</p>
<i>Line 36</i>	<div style="float: right; font-size: 24px; font-weight: bold;">1</div> <div style="clear: both; text-align: center; font-size: 18px; font-weight: bold;">36</div>	<p>Function Control input 2 (Contact 10)</p> <p>0 Hold for tachometer and batch counter 1 * Programming disabled 2 Keylock 3 Print</p>
<i>Line 37</i>	<div style="float: right; font-size: 24px; font-weight: bold;">0</div> <div style="clear: both; text-align: center; font-size: 18px; font-weight: bold;">37</div>	<p>Function Control input 3 (Contact 11)</p> <p>0 * b-Batch counter - Reset static 1 b-Batch counter - Reset edge-triggered 2 Programming disabled 3 Keylock 4 Print</p>
<i>Line 40</i>	<div style="float: right; font-size: 24px; font-weight: bold;">0</div> <div style="clear: both; text-align: center; font-size: 18px; font-weight: bold;">40</div>	<p>Output logic</p> <p>0 * Both outputs as normally open 1 P1 normally closed, P2 normally open 2 P1 normally open, P2 normally closed 3 Both outputs as normally closed</p>
<i>Line 47</i>	<div style="float: right; font-size: 24px; font-weight: bold;">0</div> <div style="clear: both; text-align: center; font-size: 18px; font-weight: bold;">47</div>	<p>Assignment of limit value P1</p> <p>0 * Upper limit value 1 Lower limit value</p>

Line 48

48	0
----	---

Assignment of limit value P2

- 0 * Upper limit value
- 1 Lower limit value

Line 49

49	0
----	---

Output behavior of lower limit value

- 0 * With starting lockout (switches only when falling below value)
- 1 Without starting lockout

Line 50

50	0
----	---

Code setting

- 0 * Code not active
- max. 9999

Line 51

51	0
----	---

Baud rate

- 0 * 4800 Baud
- 1 2400 Baud
- 2 1200 Baud
- 3 600 Baud

The programming lines 51-54 are only displayed for models with interface.

Line 52

52	0
----	---

Parity

- 0 * Even Parity
- 1 Odd Parity
- 2 No Parity

Line 53

53	0
----	---

Stop bits

- 0 * 1 Stop bit
- 1 2 Stop bits

Line 54

54	0
----	---

Address

- 0 * from
- 99 to

- - - - -	
-----------	--

The dash line indicates the end of the third programming field. By pushing ↓ or ↵, the instrument switches back to the beginning of the first programming field. Programming can be shut down at any time by pushing the keys ↑ and ↵ simultaneously.

6 Technical data

Display	7-segment LCD-display (TN) with background light On two lines
Digit size	Display of tachometer display: 7 mm Display of limit value: 4 mm
Display of measuring unit	„1/min“ „1/s“ „1/h“
Display of switching outputs P1, P2	Illustration as normally open or normally closed
Supply voltage	As ordered
Power consumption	5 VA, 4 W
Encoder supply	10 ... 26 VDC, 60 mA
Counting rate Tachometer	25 Hz or 40 kHz
Counting rate Batch counter	3 Hz, 25 Hz or 10 kHz
Data storage	> 10 years (via EEPROM)
Fixing	Clamping frame
Front measures	48 x 48 mm, casing for front plate installation
Mounting depth	100 mm
Connections	Two plug-in screw terminals With 6 poles (grid 5.08 mm) and with 9 poles (grid 3.81 mm)
Core cross-section	Max. 1.5 mm ²
Casing material	Makrolon 6485
Keypad	Short-stroke keys and front membrane
Front membrane	Polyester membrane
Weight	AC-model: ca. 260 g DC-model: ca. 140 g
Protection category	According to EN 61 010 Protection category II
Protection to DIN 40050	From the front, in built-in state with seal IP65
Operational requirements	According to contamination factor 2
Overvoltage category	According to EN 61010 Protection category II
Interference immunity	According to EN 50082 - 2 Severity grade 2-3
Emitted interference	According to EN 50081 - 2
Ambient temperature	0 ... + 50 °C
Storage temperature	-20 ... + 70 °C
Humidity	Max. relative humidity 80 %, non-condensing
General rating	EN 61010

6.1 Dimensions and cutout measures

Measures in mm

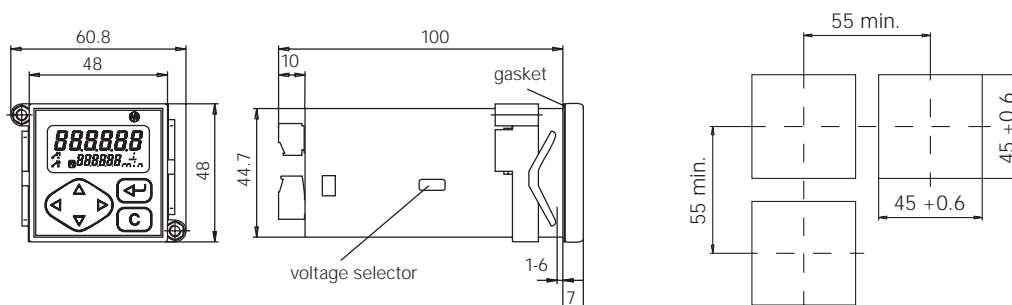

7 Model / Ordering data

