

A range of relay interface modules for use with PLC systems

Features include:

- 1 CO (SPDT) contacts rated at 10 A or 16 A  
or 2 CO (DPDT) contacts rated at 8 A, 6 A or 10 A
- AC or sensitive DC coil versions available
- Instant removal of relay using plastic retaining clip
- Supply status indication or coil protection module provided
- Identification label
- 35 mm rail (EN 50022) mounting
- Approvals (relays only, according to type): BBJ, BEAB, CSA, DEMKO, FIMKO, GOST, IMQ, NEMKO, RINA, SEMKO, SEV, cUL, UTE, VDE.

AUTOMATIC  
GATES

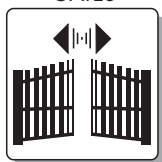

INDUSTRIAL  
APPLIANCES



ALARM  
SYSTEMS



INDUSTRIAL  
AUTOMATION



BURNERS



AIR  
CONDITIONING

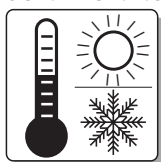

MEDICAL  
EQUIPMENT





**48.51**

Approvals (relays only) GOST   
 RINA



**48.52**

Approvals (relays only) GOST   
 RINA

### RELAY INTERFACE MODULES

- TYPE 48.51** 1 CO (SPDT) 10 A - AC or sensitive DC
- TYPE 48.61** 1 CO (SPDT) 16 A - AC or sensitive DC
- 35 mm rail (EN 50022) mounting
- Ordering information: see page 96

### RELAY INTERFACE MODULES

- TYPE 48.52.8** 2 CO (DPDT) 8 A - AC
- TYPE 48.52.7** 2 CO (DPDT) 6 A - sensitive DC
- TYPE 48.62.7** 2 CO (DPDT) 10 A - sensitive DC
- 35 mm rail (EN 50022) mounting
- Ordering information: see page 96

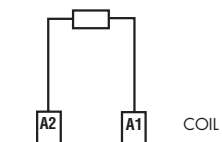
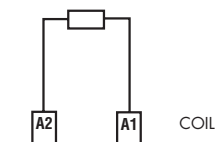
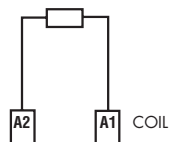
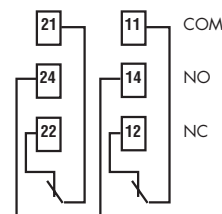
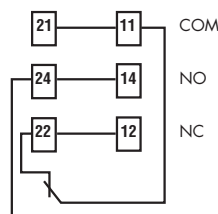
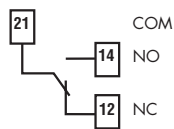
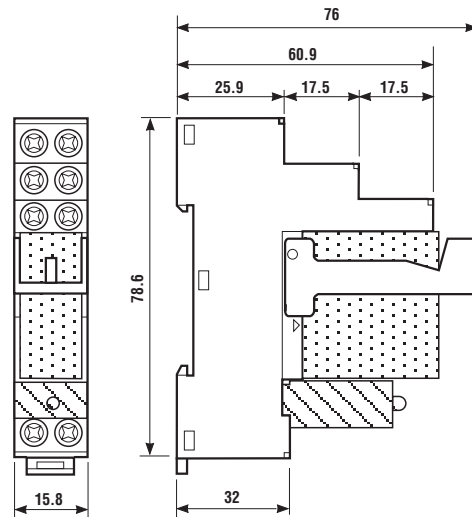
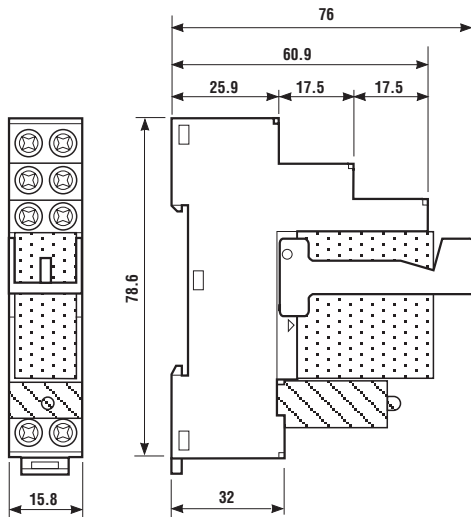

48.51

48.61

48.52.7  
48.52.8  
48.62

## TECHNICAL DATA

DIELECTRIC STRENGTH tested at leakage current $\leq 10$ mA for 1 min at 50 Hz	between coil and contacts	4,000 V		
	between open contacts	1,000 V		
	between adjacent contacts	2,000 V		
	between frame and live parts	relay without external ground		
SURGE TEST (1.2/50 $\mu$ s) BETWEEN COIL AND CONTACTS	4,000 V			
ISOLATION RESISTANCE	$\geq 20 \cdot 10^3$ M $\Omega$			
ISOLATION GROUP	C250 B250 (type 48.52.8)			
ISOLATION DISTANCES	$\geq 8$ mm between coil and contacts according to VDE 0700			
MAXIMUM SWITCHING FREQUENCY - without load - at rated load	36,000 cycles/h 1,800 cycles/h (type 48.51 - 48.52.8) 900 cycles/h (type 48.52.7 - 48.62) 600 cycles/h (type 48.61)			
MECHANICAL LIFE - AC version: - DC version:	10 · 10 <sup>6</sup> cycles 20 · 10 <sup>6</sup> cycles			
OPERATE AND RELEASE TIME - pick-up time (from 0 to U <sub>N</sub> ): - drop-out time (from U <sub>N</sub> to 0):	$\leq 15$ ms (including contact bounce) $\leq 12$ ms (including contact bounce)			
TYPE OF DUTY	continuous			
POWER LOST IN THE ENVIRONMENT - without load: - at full load:	<b>48.51</b> 0.7 W 1.2 W	<b>48.52</b> 0.7 W 1.3 W	<b>48.61</b> 0.7 W 2.0 W	<b>48.62</b> 0.7 W 2.7 W
PROTECTION CATEGORY	IP 20			
AMBIENT TEMPERATURE	(-40 ... +70°C)			

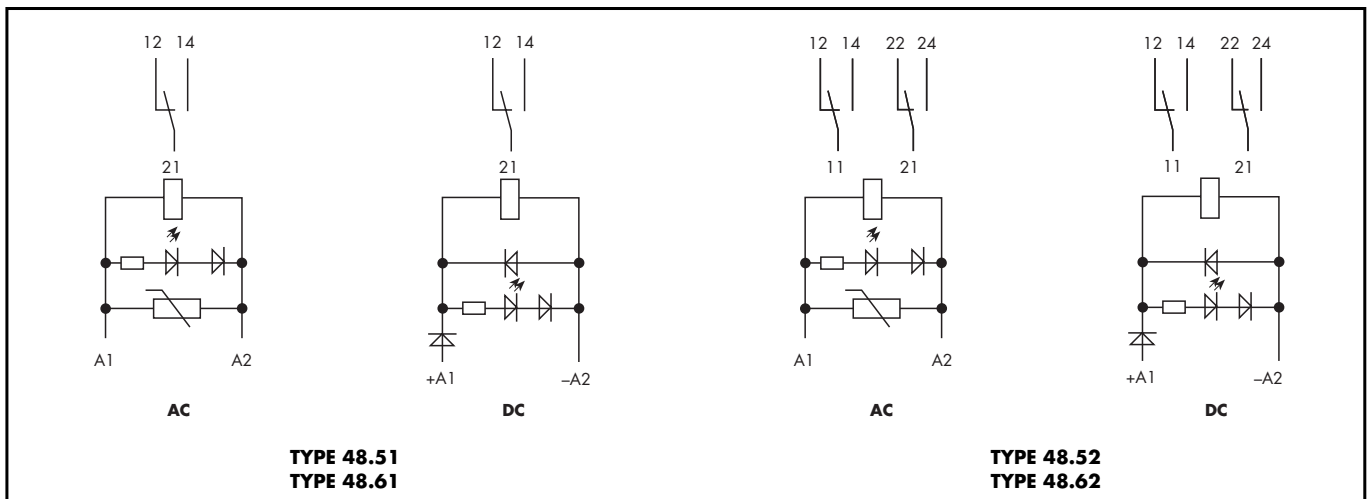

## CONTACT SPECIFICATIONS

	48.51	48.52.7	48.52.8	48.61	48.62
RATED CURRENT	10 A	6 A	8 A	16 A	10 A
MAXIMUM PEAK CURRENT	20 A	10 A	15 A	30 A	20 A
NOMINAL RATE IN AC1	2,500 VA	1,500 VA	2,000 VA	4,000 VA	2,500 VA
NOMINAL RATE IN AC15 (230 V)	500 VA	250 VA	400 VA	750 VA	500 VA
RATED VOLTAGE	250 V AC	250 V AC	250 V AC	250 V AC	250 V AC
MAXIMUM SWITCHING VOLTAGE	400 V AC	400 V AC	400 V AC	400 V AC	400 V AC
MINIMUM SWITCHING VOLTAGE	300 mW (5V/5mA)	300 mW (5V/5mA)	300 mW (5V/5mA)	500 mW (10V/5mA)	300 mW (5V/5mA)
BREAKING CAPACITY IN DC1	see diagram H 40	see diagram H 44	see diagram H 40	see diagram H 40	see diagram H 44
SINGLE PHASE MOTOR RATING (230 V)	0.37 kW/0.6 HP	0.185 kW/0.3 HP	0.3 kW/0.4 HP	0.55 kW/0.8 HP	0.37 kW/0.6 HP
CONTACT RESISTANCE: - initial	≤ 50 mΩ	≤ 50 mΩ	≤ 50 mΩ	≤ 50 mΩ	≤ 50 mΩ
STANDARD CONTACT MATERIAL	AgNi	AgNi	AgNi	AgCdO	AgNi

### F 40/1

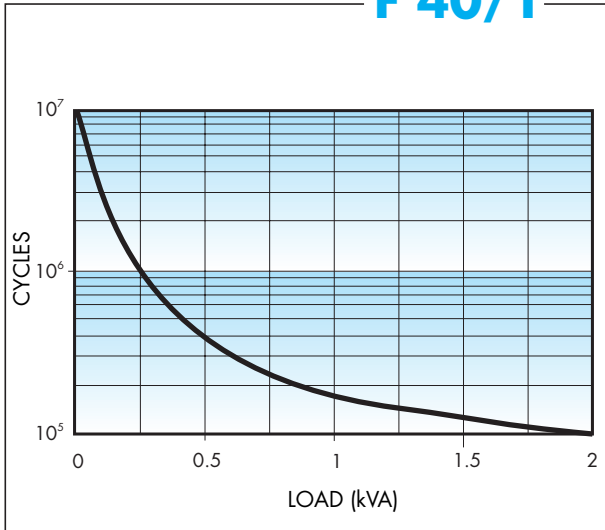

Contact life vs AC1 load.  
Relay type 40.52 (5 A) at 1800 cycles/h.

### F 40/2

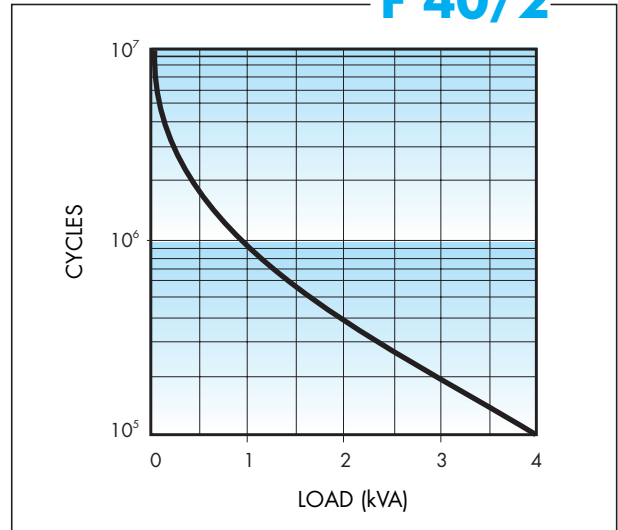

Contact life vs AC1 load.  
Relay type 40.51 (10 A) at 1800 cycles/h.  
Relay type 40.61 (16 A) at 600 cycles/h.

### F 44

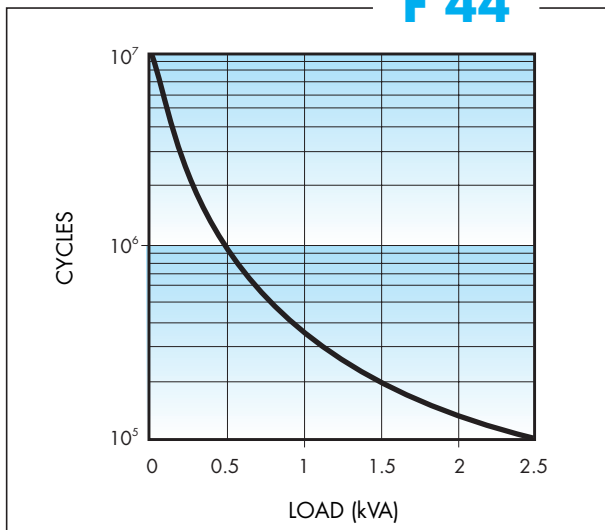

Contact life vs AC1 at 900 cycles/h.

## CONTACT SPECIFICATIONS

### H 40

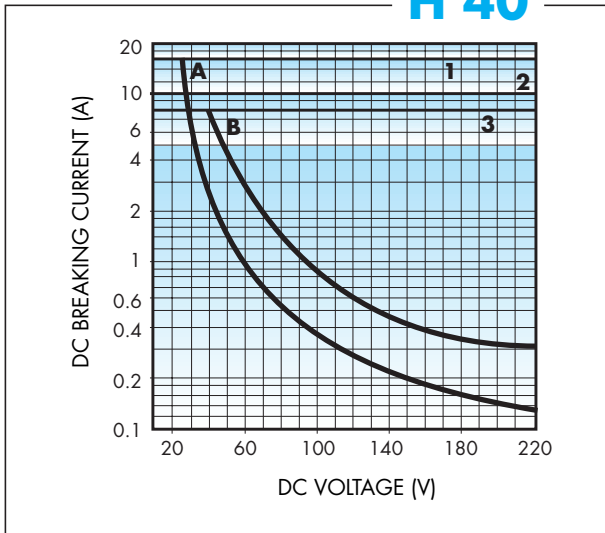

Breaking capacity for DC1 load.

**1** - type 48.61 at 600 cycles/h

**2** - type 48.51 at 1800 cycles/h

**3** - type 48.52 at 1800 cycles/h

**A** - load applied to 1 contact

**B** - load applied to 2 contacts in series

### H 44

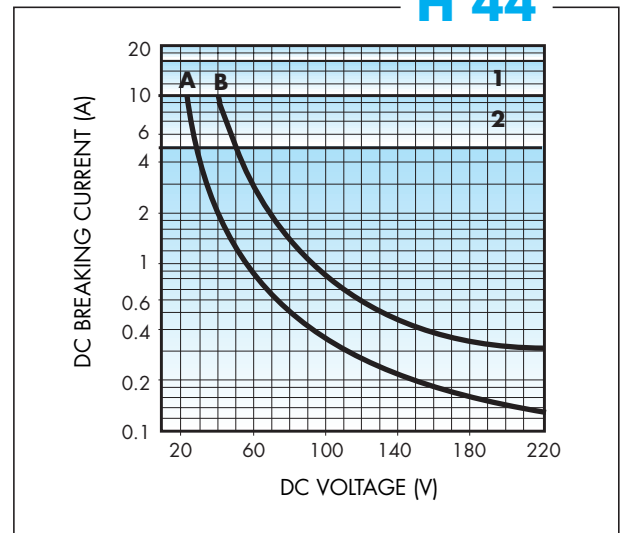

Breaking capacity for DC1 load.

**1** - type 48.52.7 at 1800 cycles/h

**2** - type 48.62 at 1800 cycles/h

**A** - load applied to 1 contact

**B** - load applied to 2 contacts in series

## COIL SPECIFICATIONS

	AC	Sensitive DC
RATED POWER	1.2 VA	0.5 W
MINIMUM POWER	(0.55...0.7) VA	0.25 W
OPERATING RANGE	(0.8...1.1)U <sub>N</sub>	(0.73...1.5)U <sub>N</sub>
HOLDING VOLTAGE	0.8 U <sub>N</sub>	0.4 U <sub>N</sub>
MUST DROP-OUT VOLTAGE	0.2 U <sub>N</sub>	0.1 U <sub>N</sub>
NOMINAL MAGNETOMOTIVE FORCE	200 A	150 A
WIRE THERMAL INSULATION CLASS	F (+155°C)	F (+155°C)

### AC VERSION DATA

R values relate to +20°C. Tolerance of R and I values: ± 10%.

Rated voltage U <sub>N</sub> V	Operating range		Nominal coil absorption I at U <sub>N</sub> 50 Hz mA
	U <sub>min</sub> V	U <sub>max</sub> V	
12	9.6	13.2	90.5
24	19.2	26.4	46
110	88	121	10.1
230	184	253	6.02

### DC VERSION DATA (0.5 W sensitive)

R values relate to +20°C. Tolerance of R and I values: ± 10%.

Rated voltage U <sub>N</sub> V	Operating range		Nominal coil absorption I at U <sub>N</sub> mA
	U <sub>min</sub> * V	U <sub>max</sub> V	
12	8.8	21	41
24	17.5	42	22.2

\* For type 48.61 and 48.62, U<sub>min</sub> = 0.8 U<sub>N</sub>

## ORDERING INFORMATION

### Ordering information

Example: a 48 series rail 35 mm (EN 50022) mount relay interface module with 2 CO (DPDT) 6 A, coil rated 24 V sensitive DC, green LED + diode.

**4 8**

**Series**

**5**

**Type**

5 = 5 mm pinning  
6 = 5 mm pinning

**2**

**No. of poles**

1 = 1 CO (SPDT) for 48.51, 48.61  
2 = 2 CO (DPDT) for 48.52 AC only  
2 = 2 CO (DPDT) for 48.52 DC only  
2 = 2 CO (DPDT) for 48.62 DC only

**7**

**Coil version**

7 = Sensitive DC  
8 = AC (50/60 Hz)

**0 2 4**

**Coil voltage**

012 = 12 V  
024 = 24 V AC only  
110 = 110 V AC only  
230 = 230 V AC only

**0 0**

**Contact material and contact circuit**

00 = Standard

**5 0**

**Options**

50 = Standard for DC:  
green LED + diode (polarity +A1)  
60 = Standard for AC:  
green LED + Varistor



095.18

### 8-way jumper link

095.18

