



Main

Range of product	OsiSense XM
Product or component type	Electronic pressure sensors
Pressure sensor type	Pressure transmitter
Pressure sensor name	XMLP
Electrical circuit type	Control circuit
Pressure sensor size	160 bar
Local display	Without
Controlled fluid	Fresh water 0...120 °C Air -30...120 °C Hydraulic oil -30...120 °C Gas -30...120 °C Refrigeration fluid -30...120 °C
Fluid connection type	G 1/4A (male) conforming to DIN 3852-A
Electrical connection	1 male connector M12 4 pins
[Us] rated supply voltage	24 V DC SELV, voltage limits: 14...30 V
Current consumption	< 10 mA
Type of output signal	Analogue
Analogue output function	0...10 V, 3-wire
Quantity per set	Set of 1
Type of packing	Individual

Complementary

Pressure setting range	0...160 bar
Maximum permissible accidental pressure	320 bar
Destruction pressure	960 bar
Materials in contact with fluid	Stainless steel type 17-4PH Stainless steel type AISI 304
Operating position	Any position
Protection type	Load short-circuit Reverse polarity
Electromagnetic compatibility	Susceptibility to electromagnetic fields conforming to EN/IEC 61000-4-3 - test level 10 V/m (f = 80...1000 MHz) Electrical fast transient/burst immunity test conforming to EN/IEC 61000-4-4 - test level 2 kV

Disclaimer: This documentation is not intended as a substitute for and is not to be used for determining suitability or reliability of these products for specific user applications

1.2/50 μ s shock waves immunity test conforming to EN/IEC 61000-4-5 - test level 500 V 12 Ohm, 1 kV 42 Ohm
 Radiated RF fields conforming to EN/IEC 61000-4-6 - test level 10 V (f = 0.15...80 MHz)
 Electrostatic discharge immunity test conforming to EN/IEC 61000-4-2 - test level 8 kV air, 4 kV contact

[Uimp] rated impulse withstand voltage	0.5 kV
Response time on output	< 5 ms for 92 % of full scale
Measurement accuracy	+/- 0.5 % of the measuring range
Accuracy	Infinity
Drift of the sensitivity	+/- 0.02 % of measuring range/°K
Drift of the zero point	+/- 0.02 % of measuring range/°K
Repeat accuracy	+/- 0.2 % of the measuring range
Mechanical durability	>= 10000000 cycles
Product weight	0.05 kg
Diameter	30 mm
Length	26 mm
Scale type	Fixed differential

Environment

Standards	CE EN/IEC 61326-1
Product certifications	CULus RCM EAC
Protective treatment	TC
Ambient air temperature for operation	-30...100 °C
Ambient air temperature for storage	-30...100 °C
Vibration resistance	20 gn (f = 10...2000 Hz) conforming to EN/IEC 60068-2-64
Shock resistance	25 gn for 11 ms conforming to EN/IEC 60068-2-27
IP degree of protection	IP65 conforming to EN/IEC 60529 IP67 conforming to EN/IEC 60529 IP69K conforming to DIN 40050

Offer Sustainability

RoHS (date code: YYWW)	Compliant - since 1136 - Schneider Electric declaration of conformity Schneider Electric declaration of conformity
------------------------	---

Contractual warranty

Warranty period	18 months
-----------------	-----------

Dimensions

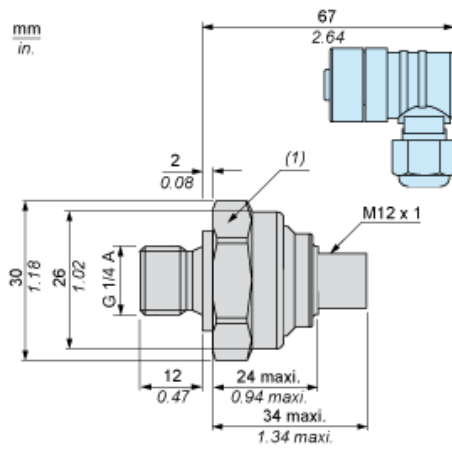

(1) SW27 Tightening torque ≤ 25 Nm / 221 Lb-in

Wiring Diagram

3-Wire Technique (0-10 V)

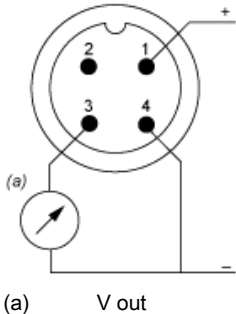

Curves

