

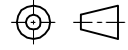

CABLE LENGTH	TOLERANCE*
ALL LENGTHS	+ 4% (OR 50mm) OF LENGTH - 0% (OR 0mm) OF LENGTH WHICHEVER IS GREATER
STRIP LENGTH	TOLERANCE*
0-7mm	±0.5mm
8-29mm	±1.0mm
30-49mm	±2.0mm
50-69mm	±3.0mm
70-100mm	±4.0mm
OVER 100mm	±5.0mm

* UNLESS OTHERWISE SPECIFIED

SOURCE DRAWING - FOR REFERENCE ONLY

- NOTES:
- "*" INDICATES CABLE LENGTH IN METERS. CONTACT TURCK TO ORDER SPECIFIC LENGTHS.
 - "/S90" DESIGNATES POLYURETHANE (TPU) CABLE.
 - "/S101" DESIGNATES FLEXLIFE-20 AND CTRACK CABLE.

RELATED DOCUMENTS 1. 2. 3. 4.	3RD ANGLE PROJECTION 	THIS DRAWING IS CONFIDENTIAL AND THE PROPERTY OF TURCK INC. USE OF THIS DOCUMENT WITHOUT WRITTEN PERMISSION IS PROHIBITED.	 High Technology Sensors and Automation Controls	3000 CAMPUS DRIVE MINNEAPOLIS, MN 55441 1-800-544-7769 (763) 553-7300 (763) 553-0708 fax turck.com
MATERIAL	ALL DIMENSIONS DISPLAYED ON THIS DRAWING ARE FOR REFERENCE ONLY	DRFT RWC	DATE 12/07/06	DESCRIPTION PKW 3M-P7X2-*--PSG 3/S90/S101
SEE SPECIFICATIONS		APVD	SCALE 1=1.0	
FINISH	CONTACT TURCK FOR MORE INFORMATION	UNIT OF MEASUREMENT MILLIMETER [INCH]		IDENTIFICATION NO.
SEE SPECIFICATIONS		DO NOT SCALE THIS DRAWING		REV K
K UPDATE RATED VOLTAGE PER ECO	KMY 05/12/14	45639	FILE: 777015002	
REV DESCRIPTION	BY DATE ECO NO.	SHEET 1 OF 1		