

Nov.1.2017 Copyright 2017 HIROSE ELECTRIC CO., LTD. All Rights Reserved.

COUNT	DESCRIPTION OF REVISIONS	BY	CHKD	DATE	COUNT	DESCRIPTION OF REVISIONS	BY	CHKD	DATE
1	DIS-C-000409	D.M	M.S	06.12.19					

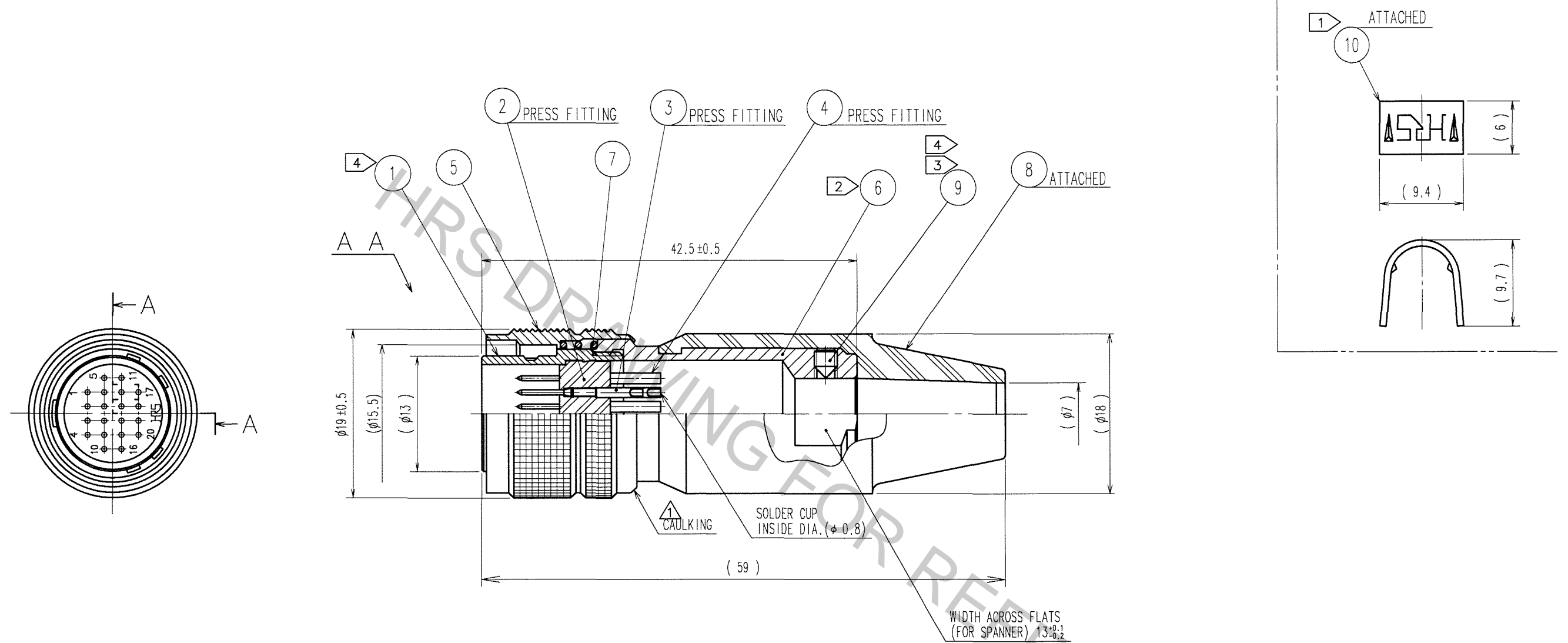

- NOTE:
- ① HAND CRIMPING TOOL, REF. NO. ⑩ : HR10A-TC-02, (CL150-0041-2)
THE HOLE DIAMETER FOR CRIMPING : φ 7.0
 - ② THE RECOMMENDED CLAMP TORQUE, REF. NO. ⑥ : 2-2.5N · m.
 - ③ ACROSS FLATS HEXAGON HEAD OF REF. NO. ⑨ : 1.27
THE RECOMMENDED CLAMP TORQUE, REF. NO. ⑨ : 0.3-0.4N · m.
REF. NO. ⑨ SHALL BE TIGHTENED WITH ITS TIPS PRESSED INTO THE DIMPLE AREA OF REF. NO. ⑩.
 - ④ LOCTITE 242, HENKEL JAPAN OR EQUIVALENT IS RECOMMENDED TO PREVENT REF. NO. ① AND ⑨ FROM LOOSENING.
 - ⑤ ONE EXAMPLE OF THE ROTATION OF REF. NO. ⑥ TO REF. NO. ① IS SHOWN.

NO.	MATERIAL	FINISH, REMARKS	NO.	MATERIAL	FINISH, REMARKS
5	BRASS	MATTE FINISH NICKEL PLATED	10	BRASS	
4	BRASS	SILVER PLATING 2μm min.	9	STEEL	NICKEL PLATING <small>JIS B 1177 HEXAGON SOCKET SET SCREW M2.6x0.45x3</small>
3	BRASS		8	CR	(BLACK)
2	POLYAMIDE	(BLACK) UL94V-0	7	STEEL	NICKEL PLATING
1	ZINC ALLOY	MATTE FINISH NICKEL PLATED	6	BRASS	NICKEL PLATING

CODE NO. (OLD)	DRAWN	DESIGNED	CHECKED	APPROVED	RELEASED
	D. MATSUNE	D. MATSUNE	E. KUNII	M. SATO	
	'05.10.01	'05.10.01	'05.10.03	'05.10.14	

DRAWING NO. EDC3-045382-73 SCALE 2 : 1 UNITS mm	PART NO. HR10A-13P-20P(73) CODE NO. CL110-0713-0-73
--	--

TO
R