

THIS DRAWING IS UNPUBLISHED. RELEASED FOR PUBLICATION
 © COPYRIGHT - By - ALL RIGHTS RESERVED.

LOC	DIST	REVISIONS					
GP	00	P	LTR	DESCRIPTION	DATE	DWN	APVD
		U2		REVISED PER ECO-11-005033	23MAR11	RK	HMR

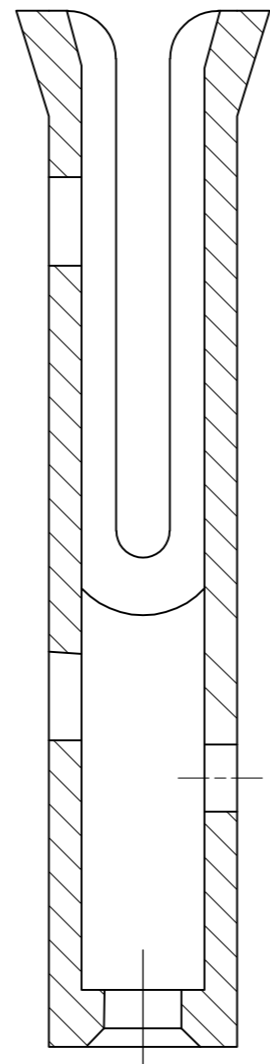
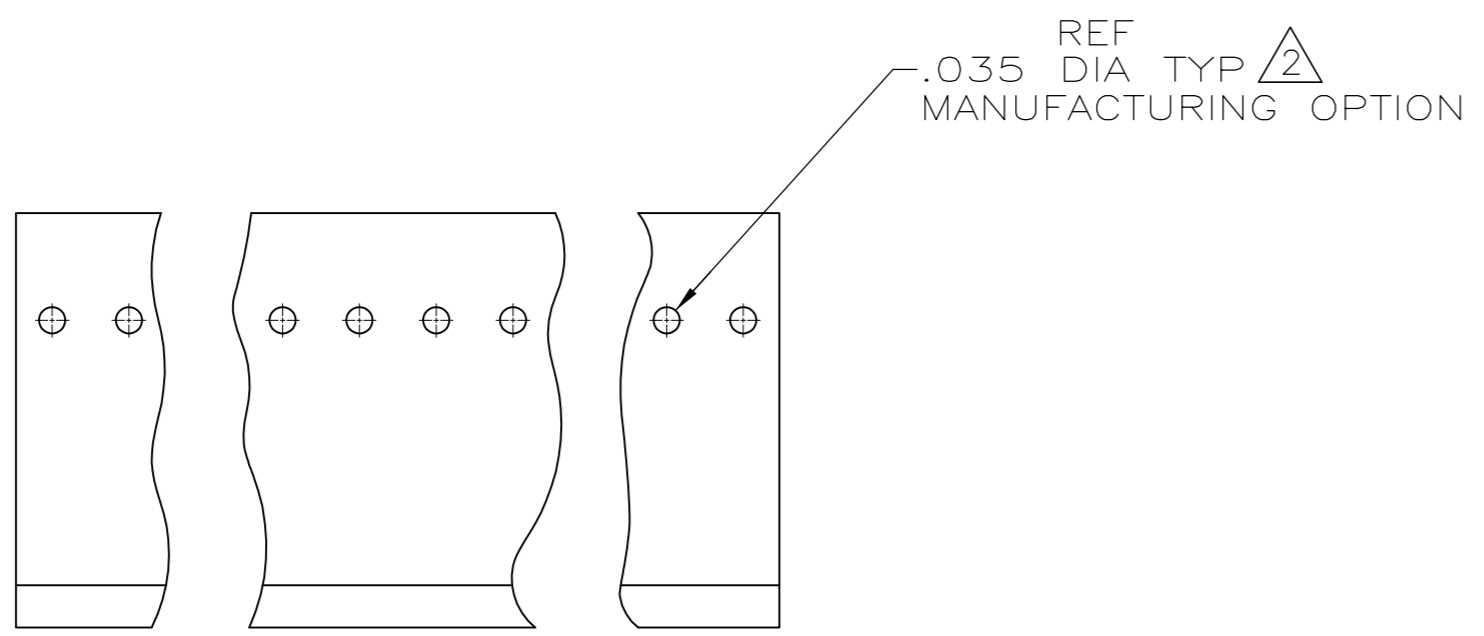
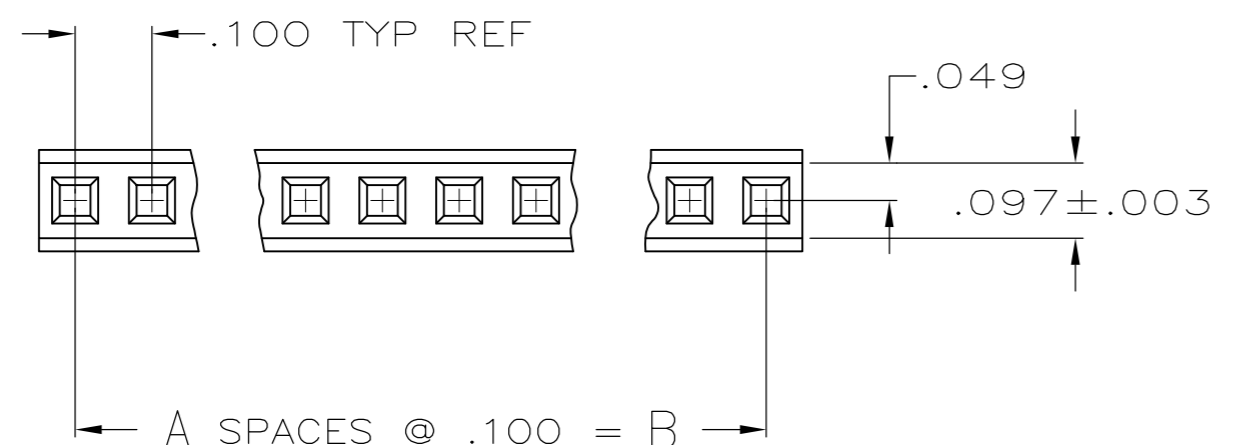
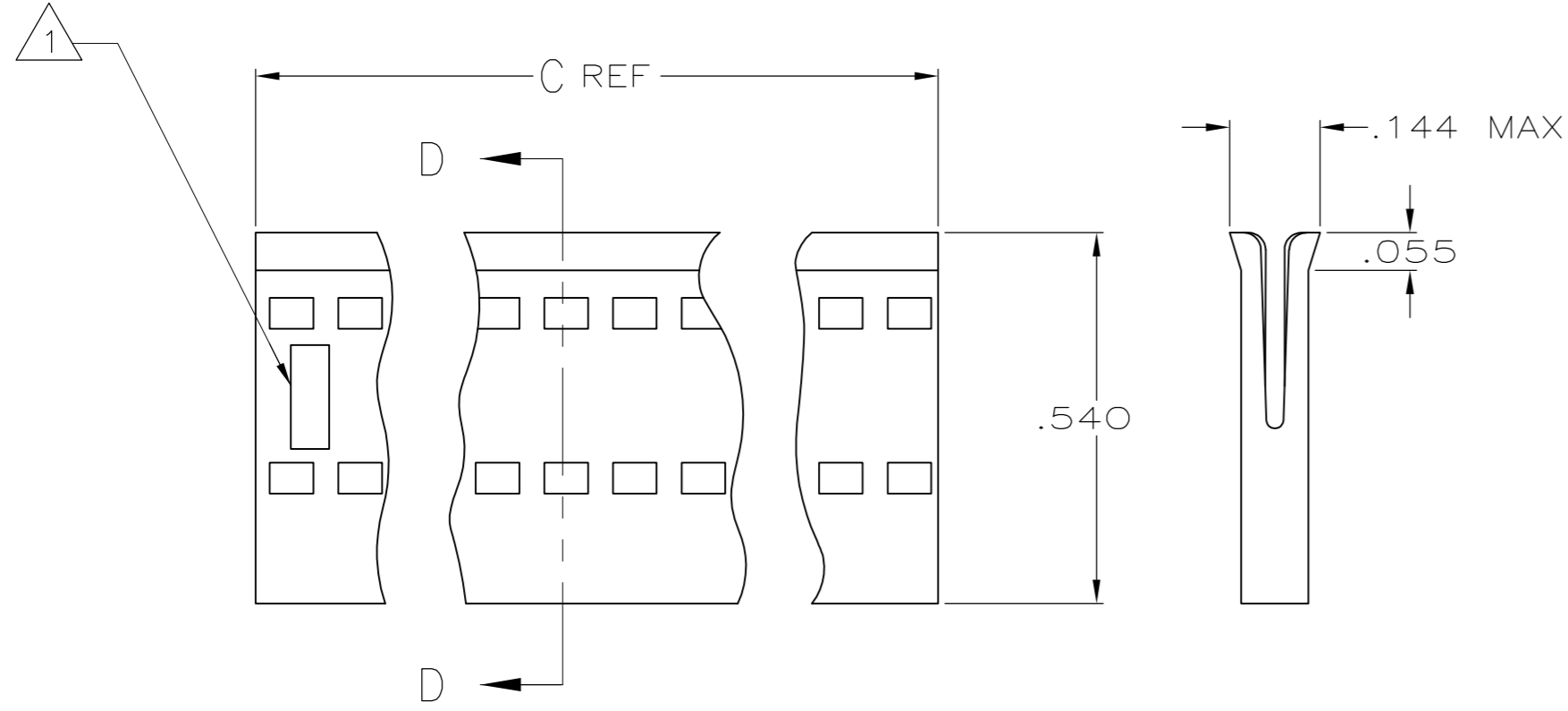
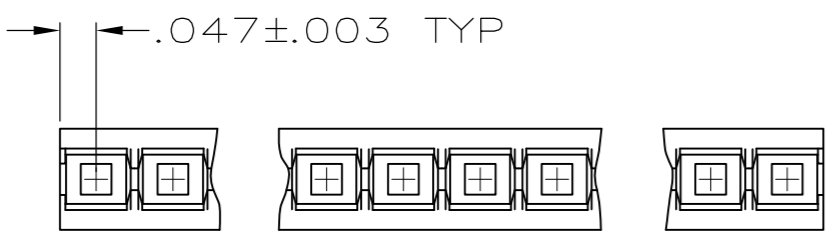

- 1 AMP TRADEMARK AND MOLD CAVITY IDENTIFICATION LOCATED AT EITHER END OF THE HOUSING IN APPROXIMATE LOCATION SHOWN.
- 2 THIS HOLE IS FOR MOLDING PURPOSES ONLY AND MAY BE FLASHED OVER,
- 3 OBSOLETE PARTS: OBSOLETE CIS STREAMLINING PER D.RENAUD/D.SINISI

OBSOLETE	2.594	2.500	25	26	2-487378-6
	3.394	3.300	33	34	2-487378-5
3 OBSOLETE	2.494	2.400	24	25	2-487378-4
	2.394	2.300	23	24	2-487378-3
3 OBSOLETE	2.294	2.200	22	23	2-487378-2
	2.194	2.100	21	22	2-487378-1
	2.094	2.000	20	21	2-487378-0
	1.994	1.900	19	20	1-487378-9
	1.894	1.800	18	19	1-487378-8
	1.794	1.700	17	18	1-487378-7
	1.694	1.600	16	17	1-487378-6
	1.594	1.500	15	16	1-487378-5
	1.494	1.400	14	15	1-487378-4
	1.394	1.300	13	14	1-487378-3
	1.294	1.200	12	13	1-487378-2
	1.194	1.100	11	12	1-487378-1
	1.094	1.000	10	11	1-487378-0
	.994	.900	9	10	487378-9
	.894	.800	8	9	487378-8
	.794	.700	7	8	487378-7
	.694	.600	6	7	487378-6
	.594	.500	5	6	487378-5
	.494	.400	4	5	487378-4
	.394	.300	3	4	487378-3
	.294	.200	2	3	487378-2
	.194	.100	1	2	487378-1
C REF	B	A	NO OF POSNS	PRODUCT PART NO	

THIS DRAWING IS A CONTROLLED DOCUMENT.

DWN D. DOLLYHIGH 10-17-84
 CHK D.R. WORTHINGTON 10-17-84

APVD -

NAME -

PRODUCT SPEC 108-9024

APPLICATION SPEC 114-16015

WEIGHT -

MATERIAL THERMOPLASTIC, FINISH -

TE Connectivity

HOUSING, RECEPTACLE, FFC

SIZE A2 CAGE CODE 00779 DRAWING NO C=487378 RESTRICTED TO -

CUSTOMER DRAWING SCALE NTS SHEET 1 of 1 REV U2