

## Instruction Manual

### IPM 6600

### 3 $\phi$ /1 $\phi$ Power Clampmeter

EN FR IT DE ES

---



 **EN 61010-2-032**  
**CAT III 600V**  
**Pollution Degree 2**

Definition of Symbols:



Caution: Refer to Accompanying Documents



Caution: Risk of Electric Shock



Double Insulation

Overvoltage Category I (CAT I):

Equipment for connection to circuits in which measures are taken to limit the transient overvoltages to an appropriate low level.

Overvoltage Category II (CAT II):

Energy-consuming equipment to be supplied from the fixed installation.

Overvoltage Category III (CAT III):

Equipment in fixed installations.

**WARNING:** If the clamp meter is used in a manner Not specified by the manufacturer, the protection Provided by the clamp meter may be impaired.



## TABLE OF CONTENTS

1.Features.....	2
3.Operating Instructions.....	6
3.1. AC+DC 1 $\phi$ 2W Power(W) and Power Factor (PF) measurement.....	6
3.2. AC+DC Voltage Measurement.....	8
3.2.1. V + Hz Dual Display.....	8
3.2.2. V + A Dual Display.....	9
3.3. AC+DC Current Measurement.....	10
3.3.1. A + Hz Dual Display.....	10
3.3.2. V + A Dual Display.....	11
3.4. AC+DC 1 $\phi$ 2W Apparent/Reactive Power Measurement(KVA+KVAR).....	11
3.5. Phase Angle Measurement.....	12
3.6. 3 $\phi$ AC+DC Balanced Power Measurement.....	14
3.6.1. W + PF Dual Display.....	14
3.6.2. KVA + KVAR Dual Display.....	15
3.6.3. V + A Dual Display.....	15
3.7. 3 $\phi$ 3W AC+DC Unbalanced Power Measurement.....	16
3.8. 3 $\phi$ 4W AC+DC Unbalanced Power Measurement.....	21
3.9. 1 $\phi$ 3W Power Measurement.....	27
3.10. Calculation of 3 $\phi$ 4W Power Factor (PF).....	31
3.11. Improving Power Factor of a 3 $\phi$ 4W Power System.....	31
3.12. Improving Power Factor of a 3 $\phi$ Balanced Power System.....	31
3.13. Improving Power Factor of a 1 $\phi$ 2W Power System.....	32
3.14. Phase Sequence Indication (for PF > 0.1).....	33
3.15. Recording Data in Memory.....	35
3.16. Reading Data in Memory.....	35
4.Specifications.....	36
5.Battery Replacement.....	39
6. Maintenance & Cleaning.....	40

## 1.Features

1. 3 $\phi$ 4W, 3 $\phi$ 3W, 3 $\phi$  Balanced, 1 $\phi$ 2W, and 1 $\phi$ 3W Power Measurement.
2. AC+DC true power, and True RMS AC Voltage and Current
3. AC+DC 2000A, AC 600V, DC 800V
4. AC+DC 1200KW(1 $\phi$ ), AC+DC 2000KW (3 $\phi$ )
5. Dual Display V+Hz, A+Hz, W+PF, KVA+KVAR, V+A
6. Phase Angle Measurement
7. 3 $\phi$  RST(L1L2L3) Sequence Indication.
8. Memory of 4 records.
9. DC/DCW Auto Zero when power clamp powering on.
10. Auto range.

## 2. Panel Description

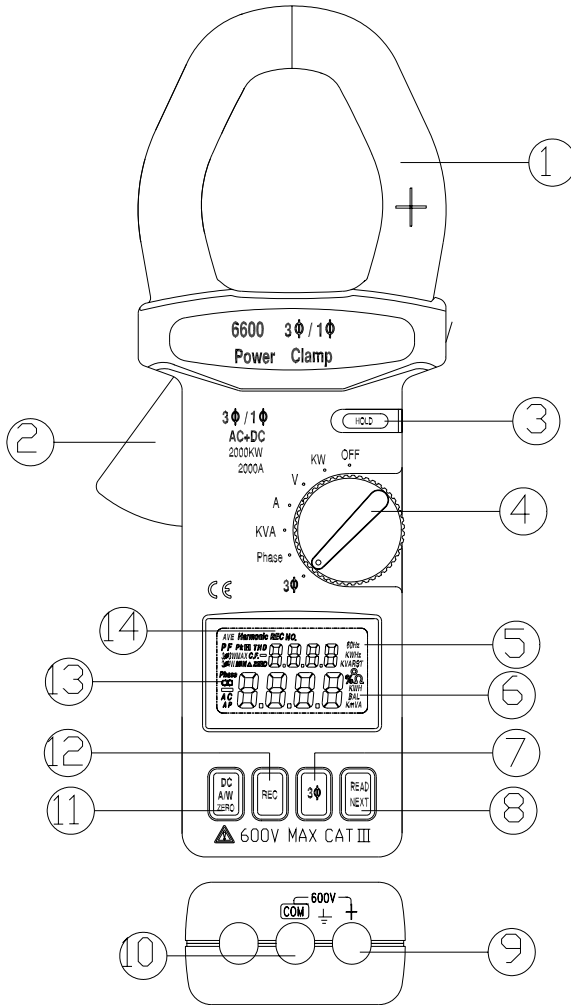

### 1. Transformer Jaw

This is used to pick up current flowing through a conductor. To measure AC+DC current or AC+DC power, the conductor must be enclosed by the jaws.

### 2. Transformer Trigger

This is used to open the jaws.

### 3. Data Hold Button

Once this button is pressed, the current reading will be held in the LCD. Press this button again to release the held reading.

### 4. Function Selection and On/Off Switch

This is used to select the desired function, such as KW, V, A, Phase, KVA, or 3 $\phi$ .

### 5. LCD display

This is a 4 digits Liquid Crystal Display with maximum indication of 9999. Function symbols, units, sign, decimal points, low battery symbols, and the zero symbol are included.

### 6. Units Symbols

Once a function is selected, the corresponding unit (KW, V, A, Phase, KVA, or 3 $\phi$ ) will be displayed in the LCD.

### 7. 3 $\phi$ 3W and 3 $\phi$ 4W Select Button (3 wire or 4 wire systems)

If the 3 $\phi$  system is not a balanced system, press this button to select between 3 $\phi$ 3W, 3 $\phi$ 4W or a balanced system. Once pressed, the 3 $\phi$ 3W symbol or 3 $\phi$ 4W symbol will be displayed depending on the function selected.

### 8. Read/Next Button

When the rotary switch is set at 3 $\phi$  function, the button is used as a NEXT button.

In the 3 $\phi$  balanced system mode, pressing the NEXT button will enable users to select W+PF, KVA+KVAR, or V+A to be displayed.

In the 3 $\phi$ 3W system mode, press the NEXT button to store the measured values  $W_{RS(L1L2)}$  and  $W_{TS(L3L2)}$ . After two values are measured and stored, the microprocessor inside the power clamp will add the two values together, display the result in the LCD and show the symbol of  $W_{RST}$  to represent

$W_{3\phi 3W}$ . To start another  $W_{3\phi 3W}$  measurement, press the NEXT button again.

In the 3 $\phi$ 4W system mode, press the NEXT button to store the measured values  $W_{RL(1)}$ ,  $W_{SL(2)}$  and  $W_{TL(3)}$ . After three values are measured and stored, the microprocessor inside the clamp will add the three values together, display the result in LCD and show the symbol of  $W_{RST}$  to represent  $W_{3\phi 4W}$ . To start another  $W_{3\phi 4W}$  measurement, press the NEXT button again.

If the rotary is not set at the 3 $\phi$  function, the button is used as a READ button. If data is stored in the memory by pressing REC button, pressing the READ button will retrieve the data from the memory. First the data number will be shown in LCD, then the data stored. Once the READ function is enabled, the REC and NO. symbols will be shown in LCD to indicate the power clamp is in READ mode. The reading shown in the LCD is not the current reading but data stored in memory. To exit the READ function, turn the rotary switch

to change function.

#### 9.V Input Terminal

This terminal is used as an input for voltage measurements.

#### 10.COM Terminal

This terminal is used as a common reference input.

#### 11. DC A/W ZERO button

When the reading of A or W is not zero, press this button once to zero the A or W reading (it is not necessary to press and hold the button). When the power clamp is zeroing, a ZERO symbol will be shown in LCD.

#### 12. REC button

The clamp meter can store 4 sets of data in memory. Once the button is pressed, the data number will be shown in LCD. A REC symbol will be shown in LCD if any data is stored. If the memory is full, the FULL annunciator will be shown in LCD. To clear the memory, turn the power off and on again.

#### 13. Low Battery Symbol

When this symbol appears, it means the battery voltage has dropped below the minimum required voltage. Refer to Section V for battery replacement.

#### 14. REC and NO. symbols

If the REC annunciator is displayed, data is stored in memory. If both REC and NO. are displayed, the reading shown in LCD is data stored in memory and not a current measurement.

### TEST EQUIPMENT RISK ASSESSMENT (UK RECOMMENDATION)

Users of this equipment and/or their employers are reminded that Health and Safety legislation requires them to carry out valid risk assessments of all electrical work so as to identify potential sources of electrical danger and risk of electrical injury such as from inadvertent short circuits. Where assessments show that the risk is significant then the use of fused test leads constructed in accordance with the HSE note GS38 "Electrical Test Equipment for use by Electricians" should be used.

### 3. Operating Instructions

#### 3.1. AC+DC 1 $\phi$ 2W Power(W) and Power Factor (PF) measurement

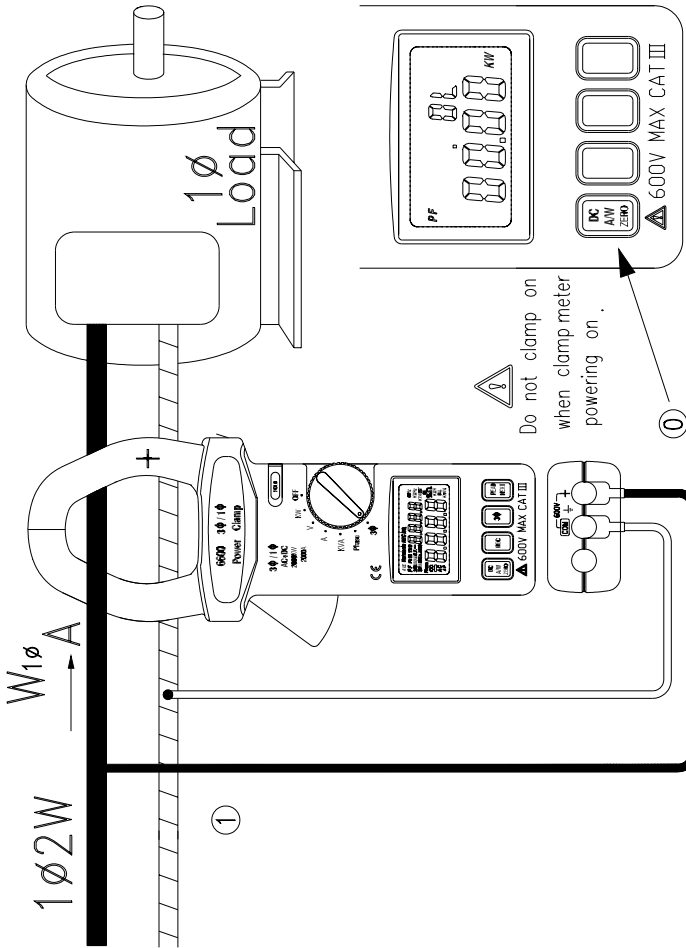

**WARNING:**

**Do not clamp on to any conductor when turning on the power of power clamp,** because the power clamp is designed to auto zero any residual magnetic field in the jaws at the moment the power clamp is turned on. Clamping around a conductor and powering the instrument up will produce inaccurate readings. ALWAYS power the instrument up prior to clamping around a conductor!

- 3.1.1. Turn the clamp on with the jaws clamped on to no conductor.
- 3.1.2. Set the rotary switch to W (refer to figure 2).
- 3.1.3. If the watt reading is not zero, press the DCA/DCW ZERO button once to zero the watt reading
- 3.1.4. Insert the test leads into the input terminals.
- 3.1.5. Connect the test probe of COM (black) terminal to the neutral line.
- 3.1.6. Connect the test probe of V (red) terminal to the power line.
- 3.1.7. Clamp on to the conductor where V (red) terminal is connected.
- 3.1.8. The power clamp will automatically select the appropriate range.
- 3.1.9. Read the Watt and PF values displayed in the LCD.

**NOTE:**

The "+" sign printed on jaw must face the power source for accurate measurement.

## 3.2. AC+DC Voltage Measurement

### 3.2.1. V + Hz Dual Display

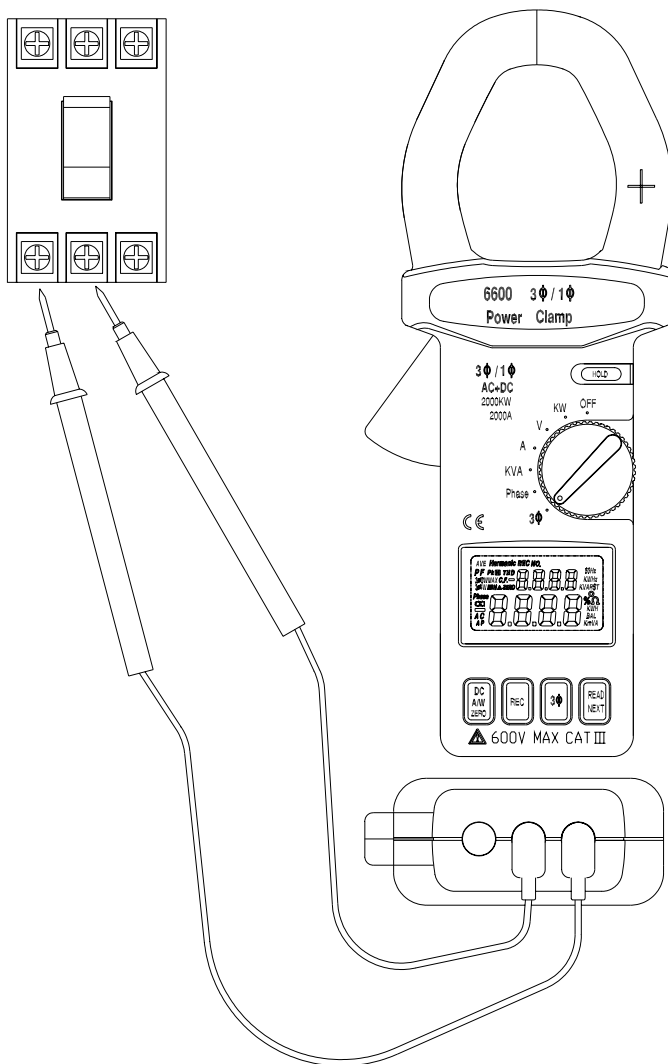

**WARNING:** Maximum input for DC V is 1000, and for AC V is 750. Do not attempt to take any voltage measurement that exceeds these limits. Exceeding these limits could cause electrical shock and damage to the clamp meter.

- a. Set the rotary switch to V (refer to figure 3).
- b. Insert the test leads into the input terminal.
- c. Connect the test probes of the test leads in PARALLEL to the circuit to be measured.
- d. The clamp will automatically select the appropriate range.
- e. Read the voltage and frequency values displayed on the LCD.

**NOTE:**

The sensitivity for voltage frequency measurement is 1V, and the frequency range is 10 - 400Hz. If the frequency is less than 10 Hz, the LCD will show 0 Hz. If the frequency is greater than 400 Hz, the LCD will show "OL".

### 3.2.2. V + A Dual Display

Follow the instructions in section 3.6.3  $3\phi$  AC+DC Balanced Power Measurement V + A.

This allows simultaneous monitoring of the absolute values of V and A.

### 3.3. AC+DC Current Measurement

#### 3.3.1. A + Hz Dual Display

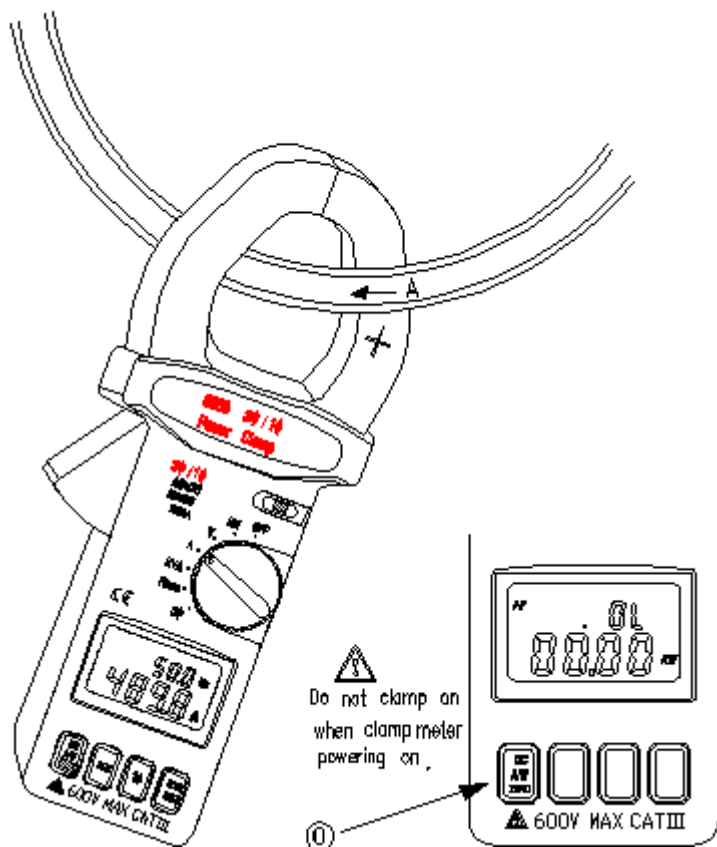

**WARNING:**

1. Do not clamp on to any conductor when turning on the power of power clamp.
2. Make sure that all the test leads are disconnected from the power clamp's terminals for current measurement.

- a. Set the rotary switch at A (refer to figure 4).
- b. Push and hold the DCA/DCW ZERO button once to zero the reading.
- c. Press the trigger to open the jaw and fully enclose the conductor to be measured. No air gap is allowed between the two jaw halves.
- d. The clamp will automatically select the appropriate range.
- e. Read the current and frequency values displayed in the LCD.

**NOTE:**

The sensitivity for current frequency measurement is 5A, and the frequency range is 10 - 400Hz. If the frequency is < 10 Hz, the LCD will show 0 Hz. If the frequency is > 400 Hz, the LCD will show "OL".

### 3.3.2. V + A Dual Display

Follow the instructions in section 3.6.3 3 $\phi$  AC+DC Balanced Power Measurement V + A. The absolute values of V and A can then be simultaneously monitored on the LCD.

### 3.4. AC+DC 1 $\phi$ 2W Apparent/Reactive Power Measurement(KVA+KVAR)

Before taking any measurements, zero the current (A) reading. Then set the rotary switch to KVA. The rest of the procedures are the same as section 3.1 (AC+DC 1 $\phi$ 2W Power(W) and Power Factor (PF) measurement). Refer to figure 2 for test lead connections and jaw clamping.

KVAR is a calculated value, and its accuracy greatly depends on the accuracy of V, A, and KW. To obtain a more accurate KVAR value when PF is greater than 0.91 ( $\phi < 25^\circ$ ), measure the phase angle and obtain the KVAR from the following equation for a pure sine wave:

$$\text{KVAR} = \text{KVA} * \sin \phi$$

**WARNING:**

Before taking measurements, users must make sure the undamped current (A) reading is zero by setting the rotary switch at A position. If the current reading is not zero, incorrect KVA and KVAR values might be obtained.

### 3.5. Phase Angle Measurement

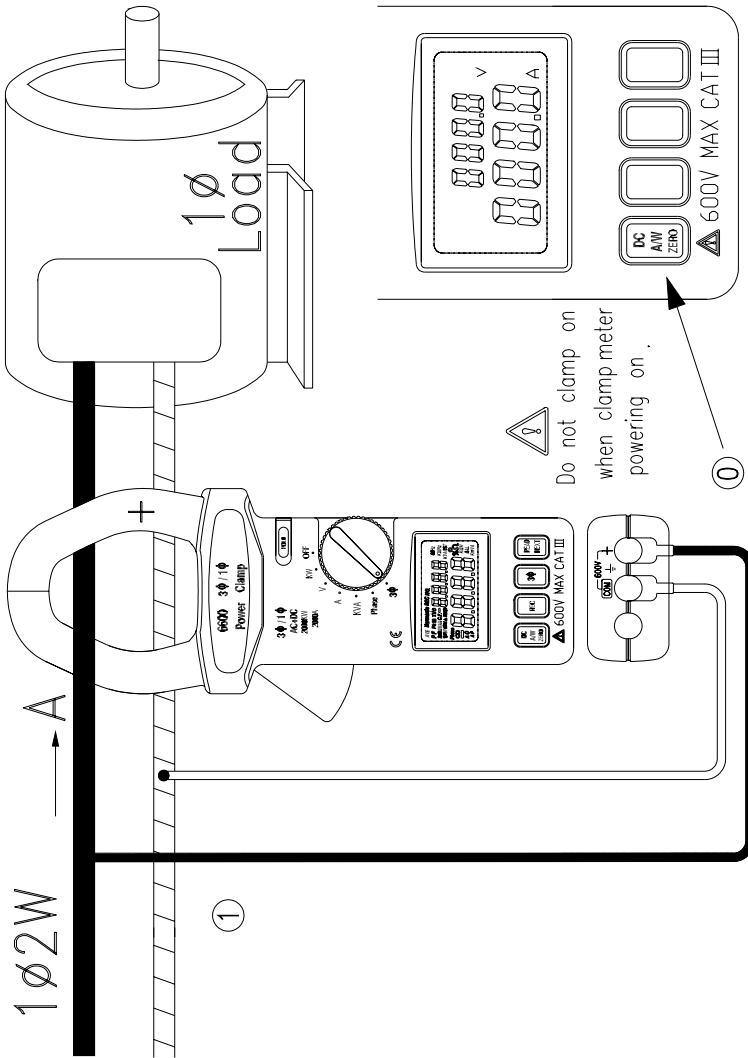

- 3.5.1. Make sure the current reading is zero by setting the rotary switch to A. If the current reading is not zero, press the DCA ZERO button.
- 3.5.2. Set the rotary switch to Phase (refer to figure 5).
- 3.5.3. Insert the test leads into the input terminals.
- 3.5.4. Connect the test probe of the COM (black) terminal to the reference line.
- 3.5.5. Connect the test probe of the V (red) terminal to the voltage signal to be detected.
- 3.5.6. Clamp on to the conductor where the V (red) terminal probe is connected.
- 3.5.7. If a current signal is detected by the jaws, the phase angle will be displayed in degrees in the LCD together with the frequency of the voltage.
- 3.5.8. If a current signal is not detected by the jaws, only the frequency of the voltage will be displayed while the phase angle is left blank.

**WARNING:**

Before taking measurements, users must zero the current (A) reading to avoid incorrect reading of phase angle. To check if current is zero, turn the rotary switch to current (A) function.

**NOTE:**

**INDUCTIVE LOAD:** Negative phase angle means that the current signal is lagging behind the voltage signal. If the connections are correct, negative phase angle also means that the load is inductive.

**CAPACITIVE LOAD:** Positive phase angle means that the current signal is leading the voltage signal. If connections are correct, positive phase angle also means that the load is capacitive.

**NOTE:**

The "+" sign printed on jaw must face the power source for correct readings.

### 3.6. 3 $\phi$ AC+DC Balanced Power Measurement

#### 3.6.1. W + PF Dual Display

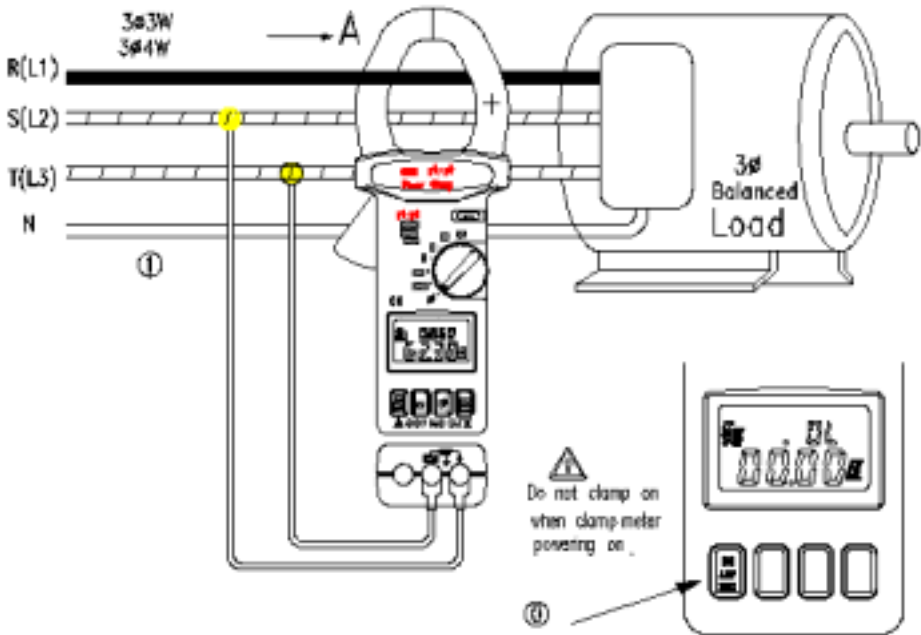

- a. Turn the power on without clamping on to any conductors.
- b. Set the rotary switch to 3 $\phi$  (refer to figure 6).
- c. The LCD will show 3 $\phi$ 3W, 3 $\phi$ 4W, and BAL symbols to indicate balanced power measurement.
- d. If the watt reading is not zero, press the DC/DCW ZERO button once to zero the watt reading
- e. Insert the test leads into the input terminals.
- f. Select one phase (eg. R or L1) as COM and connect the test probe of COM (black) terminal to that phase (eg. R or L1).
- g. Connect another test probe to the second phase (eg. S or L2).
- h. Clamp on to the third phase (eg. T or L3).
- i. The power clamp will automatically select the appropriate range.
- j. Read the Watt and PF values displayed in LCD.
- k. To view the KVA and KVAR values, press the NEXT button.
- l. To view the V and A values, press the NEXT button again.
- m. To return to the values of W and PF, press the NEXT button again.

### 3.6.2. KVA + KVAR Dual Display

Follows the steps from a to j in section 3.6.1 Then press the NEXT button once, and wait for 1.5 seconds. The LCD display will show the values of KVA and KVAR.

### 3.6.3. V + A Dual Display

Follows steps from a to j in section 3.6.1. Then press the NEXT button twice, and wait for 1.5 seconds. The LCD display will show the absolute values of V and A.

#### **NOTE:**

Specific selection of each phase is not required in 3 $\phi$  balanced power measurement. As long as each probe is connected to a different phase and the jaws are clamped around a different phase, the reading will be correct.

The "+" sign printed on jaw must face the power source for accurate measurements.

#### **NOTE:**

To find out if load is capacitive or inductive, refer to section 3.5 Phase Angle Measurement for details.

### 3.7. 3φ3W (No neutral) AC+DC Unbalanced Power Measurement

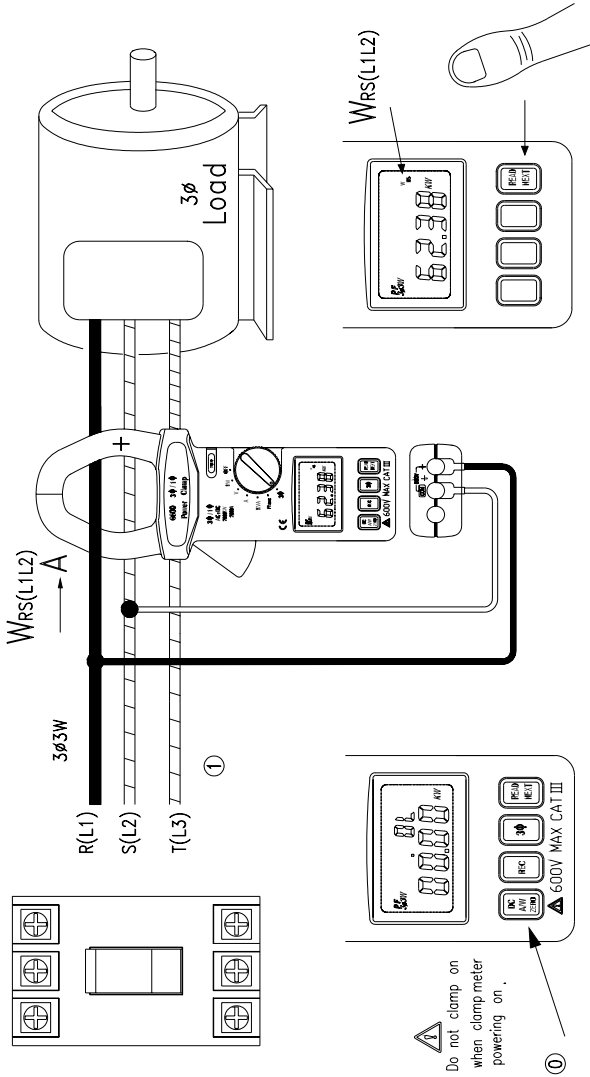

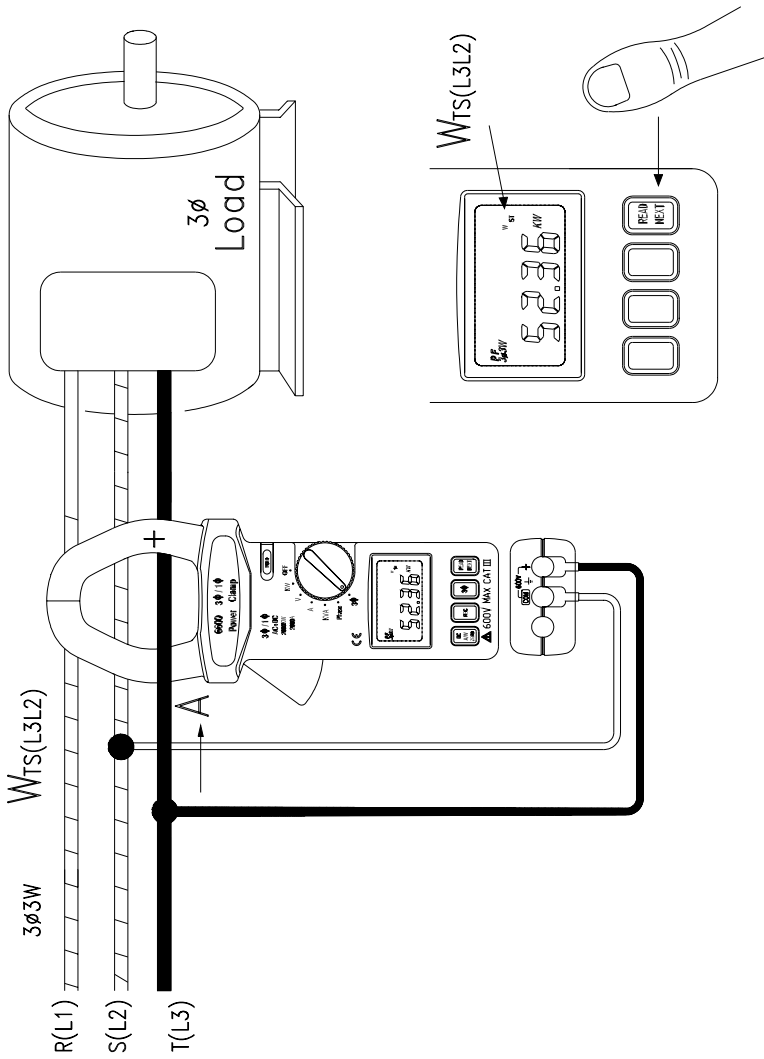

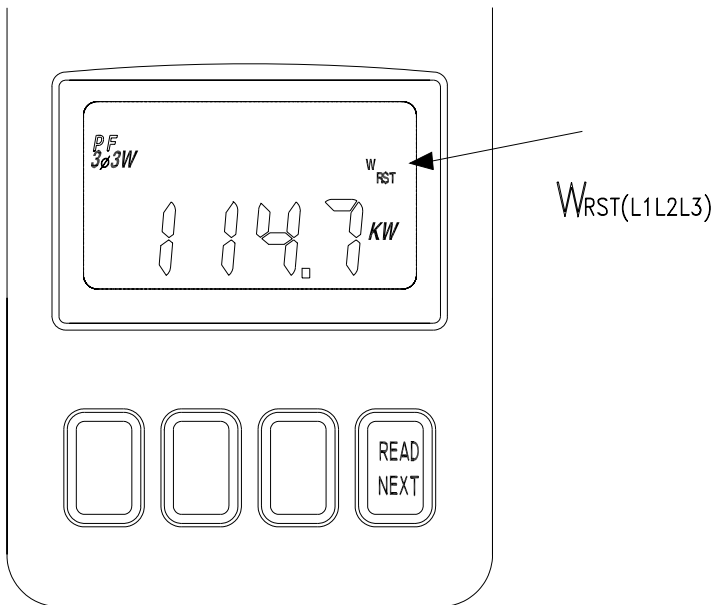

$$W_{3\phi 3W} = W_{RS(L1L2)} + W_{TS(L3L2)}$$

3.7.1. TWO MEASUREMENTS of  $W_{RS}$  (or  $W_{L1,2}$ ) and  $W_{TS}$  (or  $W_{L3,2}$ ) are required for unbalanced power measurement.

3.7.2. Firstly, measure  $W_{RS}$  (or  $W_{L1,2}$ ) (refer to figure 7).

- a. Turn the power on without clamping on to any conductor.
- b. Set the rotary switch to  $3\phi$ .
- c. Press the  $3\phi$  button once, so that only the  $3\phi 3W$  symbol is left in LCD. At this moment, the  $W_{RS}$  symbol flashes to prompt the user to take a measurement of  $W_{RS}$ .
- d. If the watt reading is not zero, press the DCA/DCW ZERO button once to zero the watt reading
- e. Insert the test leads into the input terminals.
- f. Select one phase (eg. S or L2) as COM and connect the test probe of the COM (black) terminal to that phase (eg. S or L2).
- g. Connect the test probe of V (red) terminal to the second phase (eg. R or L1).
- h. Clamp on to the same phase as in step g. (eg. R or L1).
- i. The power clamp will automatically select the appropriate range.
- j. Wait until the reading is stable, then press the NEXT button, and  $W_{RS}$  ( $W_{L1,2}$ ) symbol will disappear. At this moment,  $W_{RS}$  is stored in the memory, and the  $W_T$  ( $W_{L3,2}$ ) symbol appears and flashes to prompt the user to take a measurement of  $W_{TS}$  ( $W_{L3,2}$ ).

3.7.3. Secondly, measure  $W_{TS}$  (or  $W_{L3,2}$ ) (refer to figure 8).

- a. Disconnect the test probe from the phase where the jaws are clamped on from the previous measurement.
- b. Connect the test probe to the third phase (eg. T or L3).
- c. Open and move the jaws, so that the instrument is clamping around nothing.
- d. If the watt reading is not zero, press the DCA/DCW ZERO button once to zero the watt reading
- e. Camp around the third phase where test probe is connected to (eg. T or L3)
- f. The power clamp will automatically select the appropriate range.
- g. Wait until the reading is stable, press the NEXT button, and the  $W_T$  (or  $W_{L3,2}$ ) symbol will disappear. At this moment,  $W_{TS}$  (or  $W_{L3,2}$ ) is stored in the memory,

3.7.4. Once the NEXT button is pressed after measurements of  $W_{RS}$  (or  $W_{L1,2}$ ) and  $W_{TS}$  (or  $W_{L3,2}$ ), the power clamp will add the two values together and show the result on the LCD. The  $W_{RST}$  symbol will be shown to indicate that the wattage is of a  $3\phi 3W$  unbalanced Power (refer to figure9). PF is not shown in  $3\phi 3W$

unbalanced power mode.

$$W_{3\phi W} = W_{RST} = W_{RS(L1L2)} + W_{TS(L3L2)}$$

**NOTE:**

Once a phase is selected as COM, do not change this selection in the subsequent measurements. For example, if S (or L2) phase is selected, S (or L2) phase is always connected to the COM input terminal of power clamp during measurement of  $W_{RS}$  (or  $W_{L1L2}$ ) and  $W_{TS}$  (or  $W_{L3L2}$ ) in 3 $\phi$ 3W unbalanced power.

**NOTE:**

The "+" sign printed on jaw must face the power source for correct readings.

**NOTE:**

In the 3 $\phi$ 3W unbalanced power measurement, one of  $W_{RS}$  or  $W_{TS}$  values could be negative. So users must make sure all the connections and the clamping are correct to obtain correct power readings.



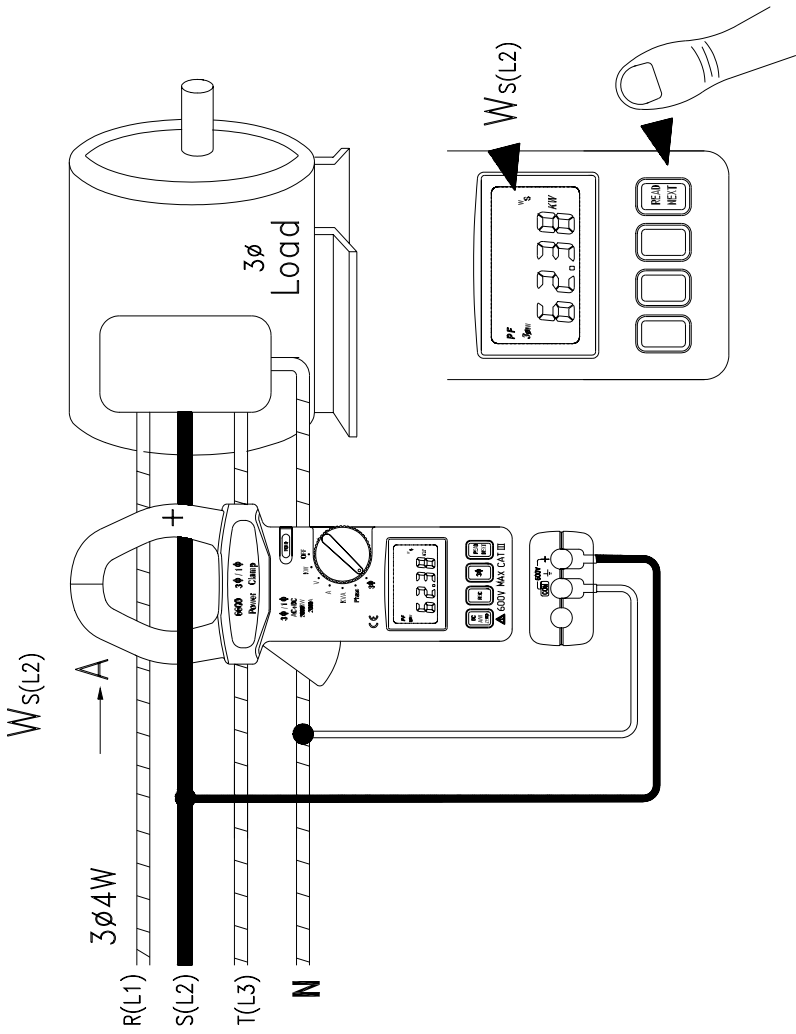

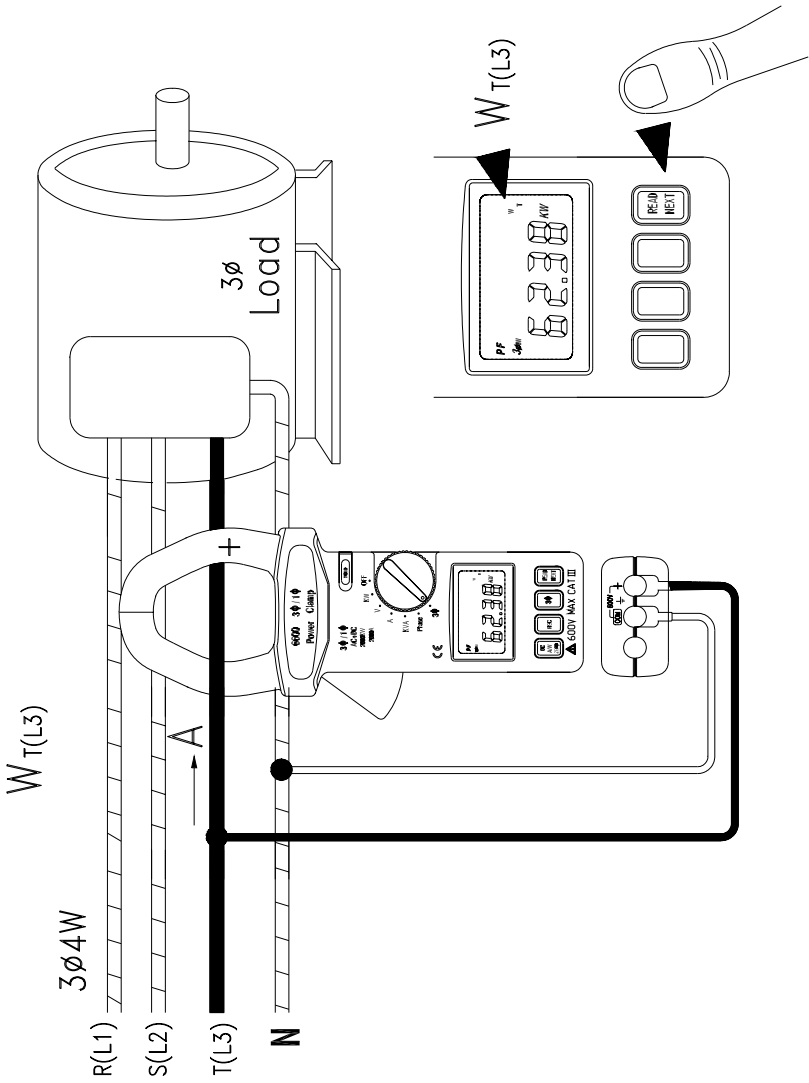

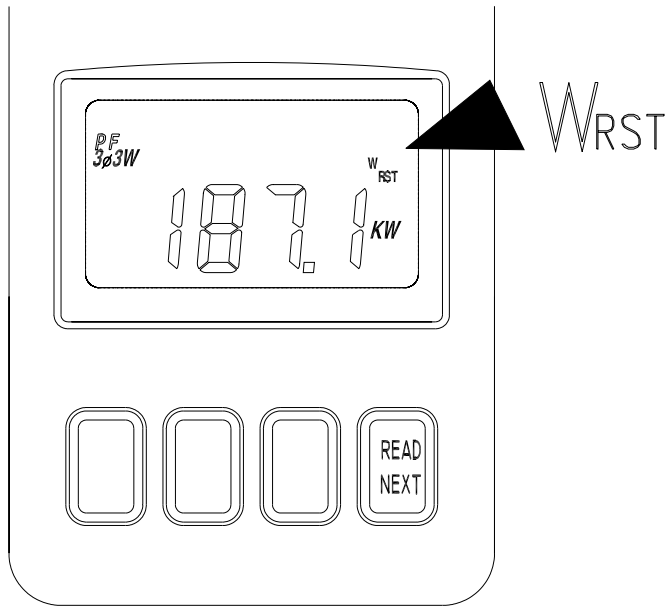

$$W_{3\phi 4W} = W_{RST} = W_{R(L1)} + W_{S(L2)} + W_{T(L3)}$$

- 3.8.1. Three measurements of  $W_R$  (or  $W_{L1}$ ),  $W_S$  (or  $W_{L2}$ ), and  $W_T$  (or  $W_{L3}$ ) are required.
- 3.8.2. Firstly, measure  $W_R$  (or  $W_{L1}$ ) (refer to figure 10).
- Turn the power on without clamping on to any conductor.
  - Set the rotary switch to  $3\phi$ .
  - Press the  $3\phi$  button twice, so that only the  $3\phi 4W$  symbol is left in the LCD. At this moment, the  $W_R$  symbol flashes to prompt the user to take a measurement of  $W_R$ .
  - If the watt reading is not zero, press the DCA/DCW ZERO button once to zero the watt reading
  - Insert the test leads into the input terminals.
  - Connect the neutral line to the COM (black) probe.
  - Connect the test probe of the V (red) terminal to the first phase (eg. R or L1).
  - Clamp on to the same phase (eg. R or L1).
  - The power clamp will automatically select the appropriate range.
  - Wait until the reading is stable, then press the NEXT button, and the  $W_R$  symbol will disappear. At this moment,  $W_R$  is stored in the memory, and the  $W_S$  symbol appears and flashes to prompt the user to take a measurement of  $W_S$ .
- 3.8.3. Secondly, measure  $W_S$  (or  $W_{L2}$ ) (refer to figure 11)
- Disconnect the test probe from the phase around which the jaws are clamped in 3.8.2.
  - Connect the test probe of the V (red) terminal to the second phase (eg. S or L2).
  - Open, move and close the jaws, so that they are clamping around nothing.
  - If the watt reading is not zero, press the DCA/DCW ZERO button once to zero the watt reading
  - Clamp around the phase to which the test probe is connected (eg. S or L2 phase)
  - The power clamp will automatically select the appropriate range.
  - Wait until the reading is stable, then press the NEXT button, and  $W_S$  symbol will disappear. At this moment,  $W_S$  is stored in the memory, and  $W_T$  flashes in the display.
- 3.8.4. Thirdly, measure  $W_T$  (or  $W_{L3}$ ) (refer to figure 12)
- Disconnect the test probe from the phase around which the jaws are clamped in 3.7.3.
  - Connect the test probe of the V (red) terminal to the third phase (eg. T or L3 phase).
  - Open, move and close the jaws, so that they are clamped around

nothing.

- d. If the watt reading is not zero, press the DCA/DCW ZERO button once to zero the watt reading
- e. Clamp around the phase to which the test probe is connected (eg. T or L3).
- f. The power clamp will automatically select the appropriate range.
- g. Wait until the reading is stable, then press the NEXT button, and the  $W_T$  symbol will disappear. At this moment,  $W_T$  is stored in the memory,

3.8.5. Once the NEXT button is pressed after measurements of  $W_R$ ,  $W_S$ , and  $W_T$ , the power clamp will add the three values  $W_R$ ,  $W_S$ , and  $W_T$  together and show the result on the LCD. The  $W_{RST}$  symbol will be shown to indicate the watt of 3 $\phi$  4W unbalanced power (refer to figure 13). PF is not shown in 3 $\phi$ 4W unbalanced power measurement.

$$W_{3\phi W} = W_{RST} = W_{R(L1)} + W_{S(L2)} + W_{T(L3)}$$

**NOTE:**

The "+" sign printed on jaw must face the power source for accurate readings.

**Note:**

In the 3 $\phi$ 4W unbalanced power measurement, the values of  $W_R$  or  $W_S$  and  $W_T$  must all be positive. If a negative reading of power is obtained, check the test lead connections and the damping of the jaws.

### 3.9. 1 $\phi$ 3W Power Measurement

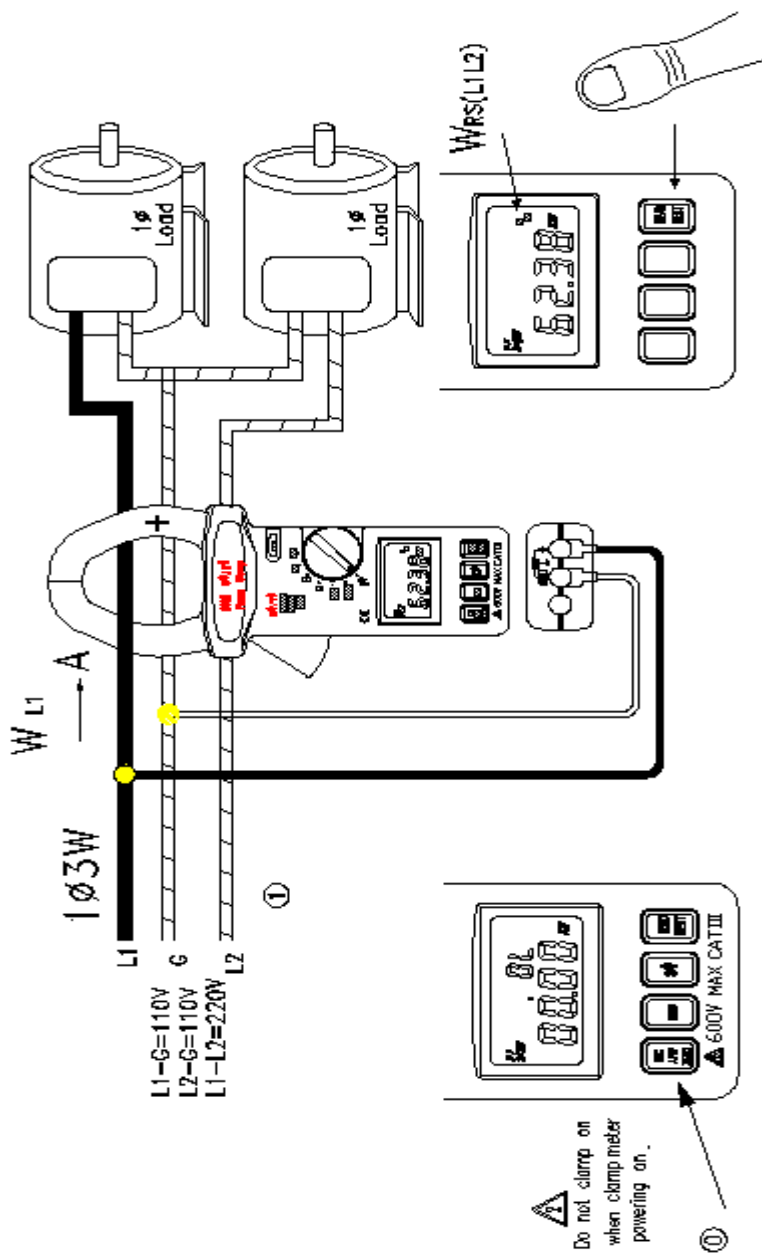

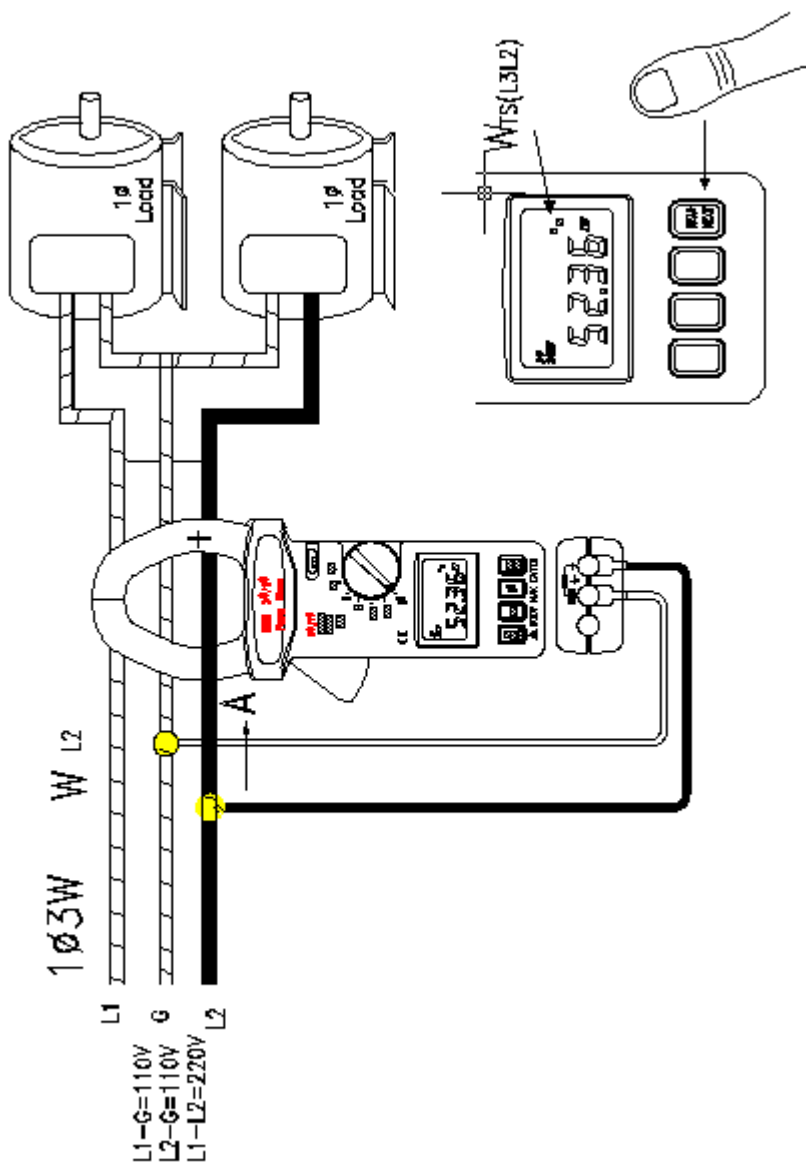

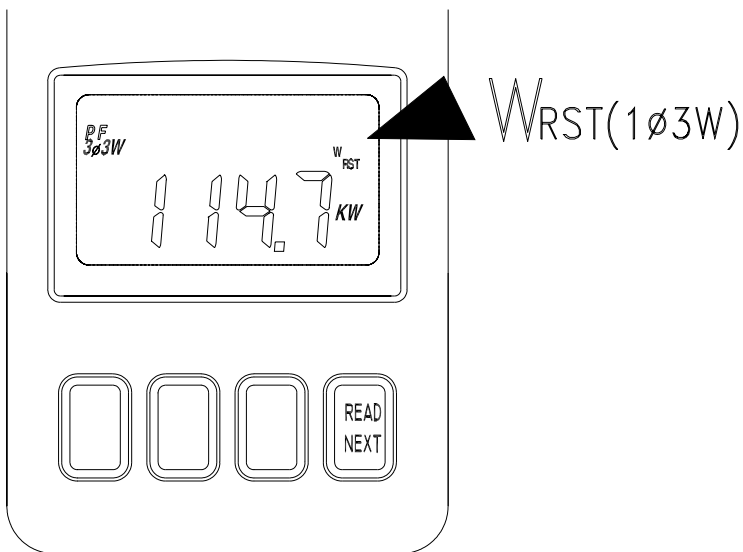

$$W_{1\phi 3W} = W_{RST} = W_{(L1G)} + W_{(L2G)}$$

1 $\phi$ 3W power measurement is similar to 3 $\phi$ 3W unbalanced power measurement except the nomenclature is different.

- 3.9.1. Two measurements of  $W_{RS}$  (or  $W_{L1G}$ ) and  $W_{TS}$  (or  $W_{L2G}$ ) are required
- 3.9.2. Firstly, measure  $W_{RS}$  (or  $W_{L1G}$ ) (refer to figure 14).
  - a. Turn the power on without clamping on to any wire.
  - b. Set the rotary switch at 3 $\phi$ .
  - c. Press the 3 $\phi$  button once, and only the 3 $\phi$ 3W symbol is left in LCD. At this moment, the  $W_{RS}$  symbol blinks to instruct users to take measurement of  $W_{RS(L1G)}$ .
  - d. If the watt reading is not zero, press the DCA/DCW ZERO button once to zero the watt reading
  - e. Insert the test leads into the input jack.
  - f. Connect the test prod of the COM (black) terminal to ground.
  - g. Connect the test prod of V (red) terminal to the second phase (eg. L1).
  - h. Clamp on to the same phase as in step g. (eg. L1).
  - i. The power clamp will automatically select proper range.
  - j. Wait until the reading is stable, press the NEXT button, and the  $W_{RS}$  ( $W_{L1G}$ ) symbol will disappear. At this moment,  $W_{RS(L1G)}$  is stored in the memory, and the  $W_T$  ( $W_{L2G}$ ) symbol appears and flashes to prompt the user to take a measurement of  $W_{TS}$  ( $W_{L2G}$ ).
- 3.9.3. Secondly, measure  $W_{TS}$  (or  $W_{L2G}$ ) (refer to figure 15).
  - a. Disconnect the test probe from the phase around which the jaws are clamped in the previous measurement.
  - b. Connect the test probe to the L2 line.
  - c. Open the jaws, so that they are clamping around nothing.
  - d. If the watt reading is not zero, press the DCA/DCW ZERO button once to zero the watt reading
  - e. Clamp around the L2 line to which the test prod is connected.
  - f. The power clamp will automatically select the appropriate range.
  - g. Wait until the reading is stable, then press the NEXT button, and the  $W_T$  (or  $W_{L2G}$ ) symbol will disappear. At this moment,  $W_{TS}$  (or  $W_{L2G}$ ) is stored in the memory,
- 3.9.4. Once the NEXT button is pressed after measurements of  $W_{RS}$  (or  $W_{L1G}$ ) and

$$W_{1\phi W} = W_{RST} = W_{RS(L1G)} + W_{TS(L2G)}$$

$W_{TS}$  (or  $W_{L2G}$ ), the power clamp will add the two values together and show the result on the LCD.

$W_{RST}$  be displayed to indicate that the wattage is of 1 $\phi$ 3W unbalanced Power

(refer to figure 16). PF is not shown in 1 $\phi$ 3W unbalanced power mode.

### 3.10. Calculation of 3 $\phi$ 4W Power Factor (PF)

- 3.10.1. During the measurement of 3 $\phi$ 4W unbalanced power, use the REC button to record the individual KW and power factor ( $KW_{R(L1)}$ ,  $PF_{R(L1)}$ ,  $KW_{S(L2)}$ ,  $PF_{S(L2)}$ ,  $KW_{T(L3)}$ , and  $PF_{T(L3)}$ ) of each phase in memory.
- 3.10.2. With this data, 3 $\phi$ 4W power factor can be calculated by the following equation.

$$KVA_{R(L1)} = \frac{KW_{R(L1)}}{PF_{R(L1)}}; KVA_{S(L2)} = \frac{KW_{S(L2)}}{PF_{S(L2)}}; KVA_{T(L3)} = \frac{KW_{S(L3)}}{PF_{T(L3)}}$$

$$KVA_{3\phi W} = KVA_{R(L1)} + KVA_{S(L2)} + KVA_{T(L3)}$$

$$PF_{3\phi W} = \frac{KW_{3\phi W}}{KVA_{3\phi W}}$$

### 3.11. Improving the Power Factor of a 3 $\phi$ 4W Power System

- 3.11.1. Measure  $KVAR_R$  (or  $KVAR_{L1}$ ),  $KVAR_S$  (or  $KVAR_{L2}$ ),  $KVAR_T$  (or  $KVAR_{L3}$ ) values of each phase.
- 3.11.2. Based upon the measured values, the required 3 $\phi$  or 1 $\phi$  capacitor (at rated voltage and frequency) can be used to improve power factor.
- 3.11.3. If the value of capacitance is needed, the value can be calculated according to the following equation:  $Capacitance(Farad) = \frac{KVAR*1000}{2\pi fV^2}$

where

$f$ : frequency in Hz

$V$ : phase voltage

- 3.11.4. It is recommended that the KVAR value of the capacitor should be a little less than the value measured.

### 3.12. Improving Power Factor of a 3 $\phi$ Balanced Power System

- 3.12.1. Measure  $KVAR_{3\phi}$  value of a balanced system.

- 3.12.2. Based upon the measured value, the required 3 $\phi$  or 1 $\phi$  capacitor (at rated voltage and frequency) can be used to improve power factor.
- 3.12.3. If the value of capacitance is needed, the value can be calculated according to the following equation:

$$\text{Capacitance(Farad)} = \frac{\text{KVAR} \cdot 1000}{2\pi f V^2}$$

where

$f$ : frequency in Hz

$V$ : line voltage

- 3.12.4. It is recommended that the KVAR value of the capacitor should be a little less than the value measured.
- 3.13. Improving Power Factor of a 1 $\phi$ 2W Power System
- 3.13.1. Measure KVAR value of a 1 $\phi$ 2W power system.
- 3.13.2. Based upon the measured value, the required 3 $\phi$  or 1 $\phi$  capacitor (at rated voltage and frequency) can be used to improve power factor.
- 3.13.3. If the value of capacitance is needed, the value can be calculated according to the following equation:

$$\text{Capacitance(Farad)} = \frac{\text{KVAR} \cdot 1000}{2\pi f V^2}$$

where

$f$ : frequency in Hz

$V$ : voltage

It is recommended that the KVAR value of the capacitor should be a little less than the value measured.

3.14. Phase Sequence Indication (for PF > 0.1)

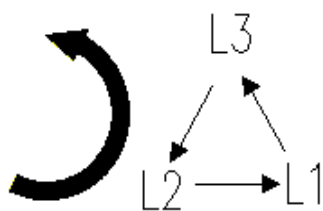
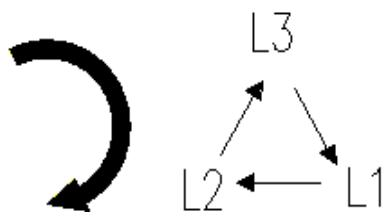

R:L1 S:L2 T:L3

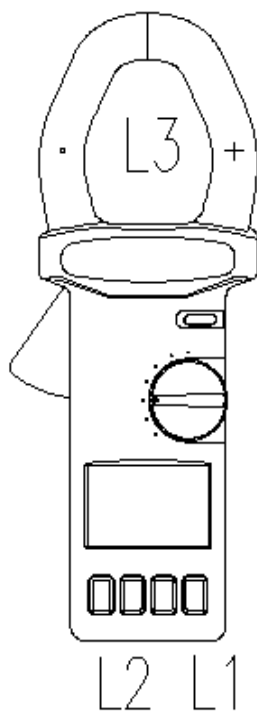

**NOTE:**

The indication of phase sequence is not limited to 3 $\phi$  balanced power. It can be used in general as long as the PF displayed is greater than 0.1.

Set the power clamp to 3 $\phi$  balanced power mode. The power clamp will automatically detect phase relation between three individual phases.

- 3.14.1. Set the rotary switch to 3 $\phi$ .
- 3.14.2. Connect the voltage input (red terminal) to R (or L1) phase, connect the COM input (black terminal) to S (or L2) phase, and clamp around the T (or L3) phase. When clamped around the T (or L3) phase, the power clamp must face the power source.
- 3.14.3. If the phase sequence is clockwise, the sequence R, S, T will flash in the display. (refer to figure 17)
- 3.14.4. If the phase sequence is counterclockwise, the sequence T, S, R will flash in the display. (refer to figure 17)
- 3.14.5. If a current signal is not detected by the jaws, only one of the R, S or T annunciators will be displayed.

**NOTE:**

The "+" sign printed on jaw must face the power source for correct measurement.

### 3.15. Recording Data in Volatile Memory

The power clamp can store 4 values in its own volatile memory. To store any data displayed in LCD, press the REC button. If the power clamp has stored 4 data already, the LCD will display FULL. The data is lost if power is turned off. The REC symbol will be displayed in the LCD if any data is stored.

**NOTE:**

If **REC** is displayed in the LCD this indicates that there is some data in the memory.

### 3.16. Reading Data in Memory

To retrieve data from the memory, press the READ button as long as rotary switch is not set to the 3 $\phi$  function.

Press the READ button and the record number will be displayed briefly, then the data is displayed afterwards. Once in the READ function, the REC. NO. symbols will be displayed in LCD.

To exit the READ function, turn the rotary switch to change the function.

**NOTE:**

If both **REC** and **NO.** symbols are shown in LCD, the readings shown in LCD are not current real-time values, they are data stored in the memory.

**4.Specifications ( at 23°C±5°C)**

**AC+DC True Power( PF 0.2 - 1.0, 3 $\phi$ 3W , 3 $\phi$ 4W 1 $\phi$ 2W, and 1 $\phi$ 3W):**

Range	Resolution	Accuracy (of reading)	Range
0 - 99.99KW	0.01KW	±2.0%±0.05KW	AC 600V, DC 800V, AC/DCA 2000A
100 - 999.9KW	0.1KW	±2.0%±0.5KW	AC 600V, DC 800V, AC/DCA 2000A
1000-1200KW	1KW	±2.0%±5KW	AC 600V DC 800V, AC/DCA 2000A

**KW Autoranging Map (PF 0.2 - 1.0, 3 $\phi$ 3W , 3 $\phi$ 4W 1 $\phi$ 2W, and 1 $\phi$ 3W)**

	0V – 200V	200V - 600VAC 200V - 800VDC
0A - 200A	0.00 - 40.00KW	0.00 - 99.99KW 100.0 - 160.0KW
200A - 2000A	0.0 - 400.0KW	0.0 - 999.9KW 1000 - 1600KW

**AC+DC True Power( Power Factor 0.2 - 1.0, 3 $\phi$  Balanced Power):**

Range	Resolution	Accuracy (of rdg)	Range
0 - 99.99KW	0.01KW	±2.0%±0.5KW	AC 600V, DC 800V, AC/DCA 2000A
100 - 999.9KW	0.1KW	±2.0%±0.5KW	AC 600V, DC 800V, AC/DCA 2000A
1000-2000KW	1KW	±2.0%±5KW	AC 600V, DC 800V, AC/DCA 2000A

**POWER FACTOR (PF)**

$$PF = \frac{KW}{KVA}$$

**AC+DC Voltage( True RMS, Crest Factor < 4, Autorange, OverloadProtection is**

**800VAC for all ranges)**

Range	Resolution	Accuracy (of reading)		Input Impedance
		DC, 50/60 Hz	40–400Hz	
0-200V	0.1V	±1.5%±5dgts	±2.0%±5dgts	10MΩ
200-500V	0.1V	±1.5%±5dgts	±2.0%±5dgts	10MΩ
500–600VAC 500–800VDC	1V	±1.5%±5dgts	±2.0%±5dgts	10MΩ

**AC+DC Current (True RMS, Crest Factor < 4):**

Range	Resolution	Accuracy (of reading)		Overload Protection
		DC, 50/60 Hz	40–400Hz	
0–200A	0.1A	±1.5%±5dgts	±2.0%±5dgts	AC 3000A
200–500A	0.1A	±2.0%±5dgts	±2.5%±5dgts	AC 3000A
500-2000A	1A	±2.5%±5dgts	±3.0%±5dgts	AC 3000A

**Phase Angle** (must zero current reading before measurement)

Range	Accuracy	Sensitivity	Remark
50/60 Hz	± 2.0°	V > 100V, A > 10A	Zero Crossing Detection

† If a current signal is not detected, the phase angle will be left blank in LCD.

**Frequency (if < 10 Hz, Hz = 0)**

Range	Accuracy	Sensitivity
50/60 Hz	±2digits	V: > 1V, A: > 5A
10–400 Hz	0.5% ± 2 digits	V: > 1V, A: > 5A

Indoor Use

Conductor Size:	Cable $\phi$ 55mm. (approx.)
	Bus Bar 65mm(D) x 24mm(W)
Battery Type:	9V
Display:	2 X 4 Digits Dual Display LCD
Range Selection:	Auto
Overload	Indication: OL
Power	Consumption:  25 mA (approx.)
Low battery Indication:	
Sampling Time:	0.5 sec. (V and A)
	1.6 sec. (W)
Operating Temperature:	4°C to 50°C
Operating Humidity:	less than 85% relative humidity
Altitude:	up to 2000m
Storage Temperature:	-20°C to 60°C
Storage Humidity:	less than 75% relative
Dimensions:	271mm (L) x 112mm (W) x 46mm (H)
	10.7" (L) x 4.4" (W) x 1.8" (H)
Weight:	647 g/22.8 oz (battery included)
Accessories:	Carrying bag x 1
	Users manual x 1
	9V battery x 1 (Installed)

## 5. Battery Replacement

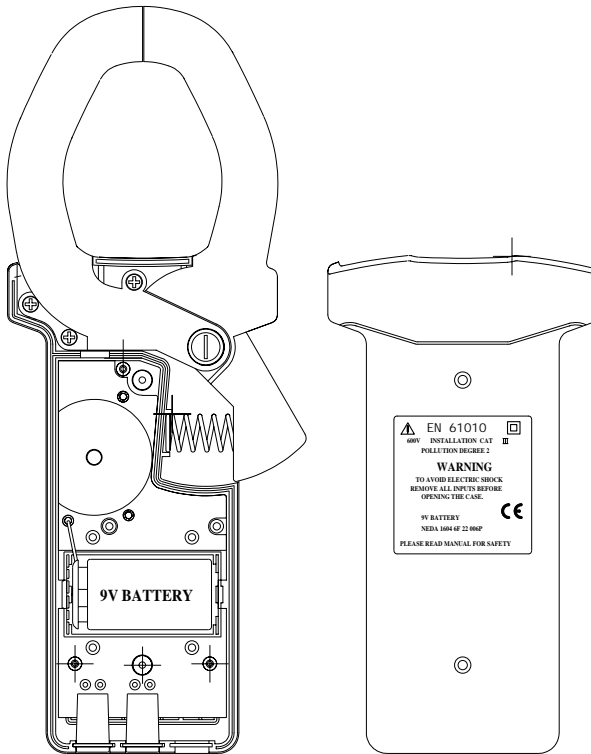

When the low battery symbol is displayed on the LCD, replace the old battery with a new battery.

- 5.1. Turn the power off and remove the test leads from the power clamp.
- 5.2. Remove the screws of the bottom case.
- 5.3. Lift and remove the bottom case.
- 5.4. Remove the old battery.
- 5.5. Insert a new 9V battery.
- 5.6. Replace the bottom case and secure the screws.

**WARNING:** do not touch or adjust any parts inside the power clamp when the bottom case is open.

## **6. Maintenance & Cleaning**

Servicing not covered in this manual should only be performed by qualified personnel. Repairs should only be performed by qualified personnel.

Periodically wipe the case with a damp cloth and detergent; do not use abrasive or solvents.

Iso-Tech  
460 Alexandra Road, #15-01A  
PSA Building  
Singapore 119963

**Europe**

Iso-Tech  
PO Box 99  
Corby  
Northamptonshire  
NN17 9RS  
United Kingdom

**Japan**

West Tower (12th Floor)  
Yokohama Business Park  
134 Godocho, Hodogaya  
Yokohama, Kanagawa 240-0005 Japan

**USA**

7410 Pebble Drive  
Fort Worth  
Texas 76118-6961

**Canada**

1701 Woodward Drive  
Ste 108 Ottawa  
Ontario K2C 0R4, Canada

**South America**

Av. Pcte. Eduardo Frei M. 6001-71  
Centro Empresas El Cortijo  
Conchali, Santiago, Chile

Jun-2010