

## DC1400 Energy Controller

### SELF CONFIGURING OPTIMISER/COMPENSATOR WITH BOILER SEQUENCE AND HWS CONTROL

#### DC1400

Specification No. DC1400

The DC1400 energy controller is a self configuring optimiser/compensator capable of controlling one or two boilers in sequence with HWS time control. The DC1400 provides the best routines for efficient temperature control in small buildings. It is designed for easy installation and operation in the small/medium commercial property and encompasses the major control requirements of current Building Regulations.

Fundamentally, the controller recognises the application by the sensors that are connected to it, so therefore it is self-configuring. The use of sensible default settings, and a self-adaptive optimiser and compensator, means that the system can be set to work after installation by programming the required temperatures and times. The controller will automatically fine tune, matching the building's requirements. Used either for controlling one boiler or two boilers in sequence with optional automatic weekly rotation, it provides stable control conditions, eliminating boiler short cycling during light load conditions.

All the DC1400's settings are accessible for adjustment, by entering a password. The simplicity does not stop there. Easy access to override the control, either by means of a front panel mounted switch, or by a remote switch unit, allows the heating to be turned on and off without the need to change the settings at the unit. In addition, one outside sensor can pass information to other DC1400s on the same site.

The DC1400 uses standard Satchwell sensors, making this product ideal for upgrading from CSMC and CMC controllers without the need for extensive rewiring.



#### FEATURES

- Self configuring controller
- Self adaptive optimum start
- Self adaptive optimum stop
- Day economy switch off
- Boiler sequence control
- Weekly boiler rotation
- Valve compensation
- Boiler compensation
- Valve/Boiler compensation
- Self-adaptive compensator option
- Adjustable space temperature reset on compensator
- Night set back (space or flow temperature)
- Variable pump overrun
- Hot water time channel
- Multi-stage frost protection
- Valve/Pump summer exercise
- Holiday scheduling
- BST/GMT auto clock change
- Summer/Winter operation
- Front panel selector auto / summer / cont / frost / service
- Remote override facility
- Alarm indicator
- Uses standard Satchwell sensors



#### Data Sheets

DS 1.001 - DRT Sensors  
 DS 1.203 - DWT, DST Sensors  
 DS 1.204 - DWT0002 Sensor  
 DS 1.402 - DOT Sensor  
 DS 3.401 - ALM Actuator  
 DS 3.215 - ARM Actuator  
 DS 3.005 - AVUM Actuator  
 DS 3.201 - RM Actuator  
 DS 2.044A - DC1400 Controller Wiring and Commissioning Information  
 DS 2.043 - DC1100 Remote Switch Unit

## SPECIFICATIONS

<b>Type:</b>	DC1400 Self Configuring Optimiser/Compensator (DC1400)
<b>Power Supply:</b>	230Vac 50Hz
<b>Consumption:</b>	15VA
<b>Fuse:</b>	160mA T 250V
<b>Relay Ratings:</b>	SPNO 3A resistive 1A inductive 230Vac
<b>Ambient Temperature Limits:</b>	0°C to 50°C
<b>Storage Temperature:</b>	-10°C to 60°C
<b>Max: Ambient Humidity:</b>	Up to 95% RH non-condensing
<b>Control Range:</b>	-40°C to 120°C
<b>Accuracy:</b>	-40°C to -30°C: $\pm 2^\circ\text{C}$ , -29°C to 70°C: $\pm 1^\circ\text{C}$ , 71°C to 120°C: $\pm 0.5^\circ\text{C}$
<b>Resolution:</b>	0.1°C
<b>Weight:</b>	1.2kg
<b>Complies with EC Directives:</b>	EMC, LVD

---

## ACCESSORIES

Remote Switch Unit (Part No. 04-03-109)  
RB1 Interface Relay (Part No. 03-21-001)

---

## COMPATIBLE DEVICES

### Sensors:

DRT3451, DRT3453 Room Temperature (see DS 1.001 for details)  
DOT2301, DOT0002 Outside Air Temperature (see DS 1.402 for details)  
DWT1701, DWT1702, DWT0001 Immersion Temperature with pocket (see DS 1.203 for details).  
Also DWT0002 Fast Immersion Temperature (DS 1.204).  
DST1601, DST1603, DST0001 Pipe Surface Temperature (Strap-on) (see DS 1.003 for details)

### Actuators:

ALM (see DS 3.401 for details)  
ARM (see DS 3.215 for details)  
AVUM (see DS 3.005 for details)  
RM (see DS 3.201 for details)

---

## CONSTRUCTION

<b>Case:</b>	Plastic with transparent perspex lid
<b>Protection Class:</b>	IP 40
<b>Conduit Entries:</b>	20.5mm knock-out cable entries
<b>Indication:</b>	LCD Panel providing continuous information on the DC1400 control status. Displays current date and time, one of the system temperatures and the current control action. The LCD can be used to view alarms, and in SET programming mode, the LCD is used to display setting information. A column of LEDs indicate the status of the controller, including alarms.
<b>Mounting:</b>	Panel or wall mounting. Panel cut-out 186mm x 137mm with a depth clearance of 87mm at the rear.

---

## INPUTS

Outside air temperature  
Boiler return sensor  
Boiler flow sensor  
Space sensors (2 max.)  
Digital input to provide for controller override

## OUTPUTS

Boiler No. 1  
Boiler No. 2  
Pump  
Valve open  
Valve close  
Hot water

**LCD DISPLAY**

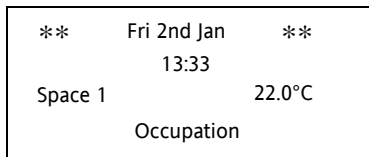

A large front panel display normally shows the time, date, a selected temperature and the current operating status. It is also used to view alarms and change settings.

Four keys (Up, Down, Exit and Enter) adjacent to the display are used to change settings within the controller. These are used when the front panel selector switch is set to SET.

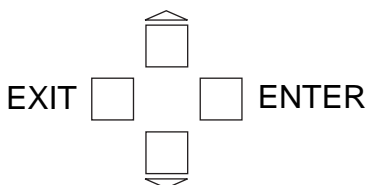

**FRONT PANEL SWITCH**

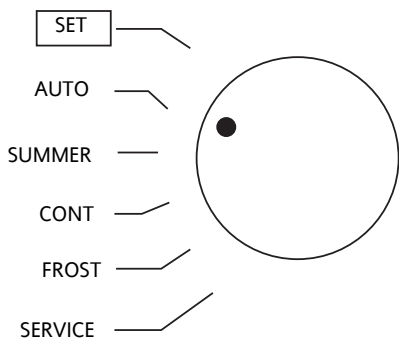

The front panel switch allows control selection. This ranges from normal automatic control of heating and hot water to summer operation of hot water only, constant heating, frost protection only and a set position to change times and temperatures. A service mode allows for plant maintenance without alteration of controller settings.

**LED INDICATORS**

Six LEDs indicate which functions are on, clearly showing the controller's status, and a seventh LED displays a number of operating faults:

- Boiler 1
- Boiler 2
- Pump
- Valve open
- Valve close
- Hot water
- Alarm

**REMOTE SWITCH UNIT (Part No. 04-03-109)**

The Remote Switch Unit provides a means of overriding the normal control of the controller by switching the controller into one of four modes (AUTO, SUMMER, HEATING ON, HOLIDAY).

This is a repeat of the function on the controller front panel switch, but allows remote operation from some convenient location.

The override switch is operable only when the controller front panel switch is in the AUTO position.

**SCHEMATIC TERMINAL DETAILS**

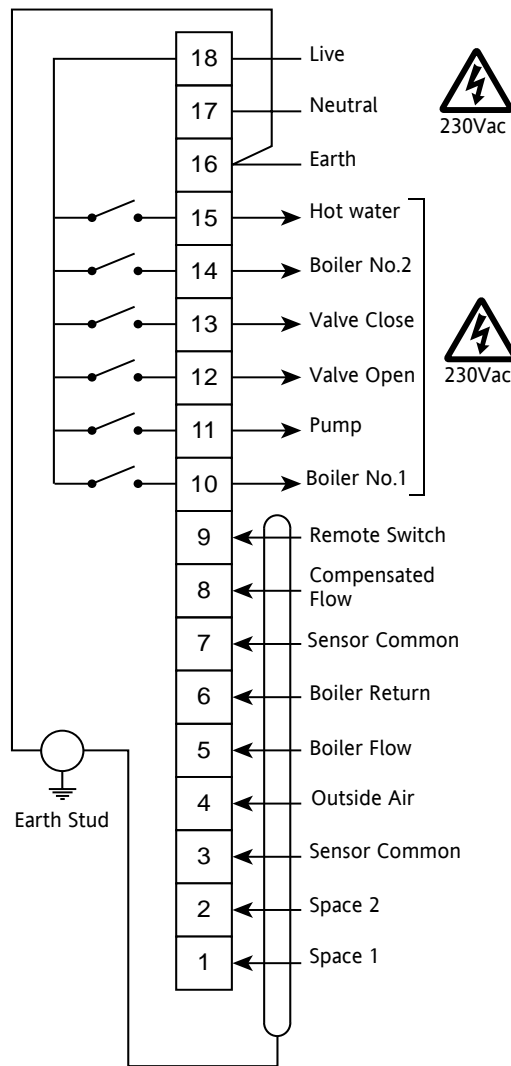

Input Wiring:  
Screened Twisted Pair, Screen Earthed at Stud only.



**WARNING - ELECTRICAL SHOCK HAZARD.**

**THIS CONTROLLER OPERATES FROM A 230Vac MAINS SUPPLY AND PROVIDES SWITCHED 230Vac OUTPUTS. ALWAYS ISOLATE THE MAINS SUPPLY FROM THE UNIT BEFORE REMOVING THE CONTROLLER FROM THE WIRING BASE.**

**TYPICAL APPLICATION DETAIL**

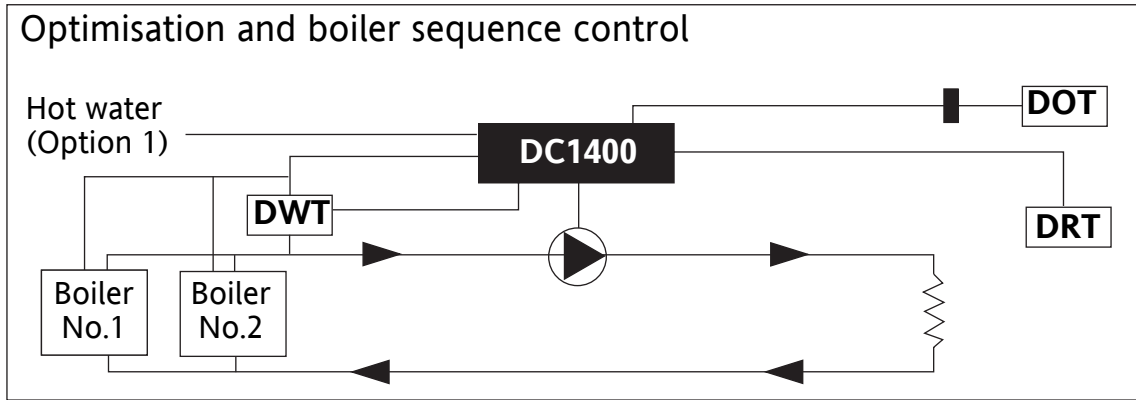

**Equipment Schedule**

- DC1400 controller
- DRT3451, DRT3453 or DRT0001 Space sensor
- DOT2301, DOT2301 or DOT0002 Outside sensor
- DWT1701, DWT1702, DWT0001 or DWT0002 Boiler flow sensor

**Features**

- Self adaptive optimum start
- Optimum stop
- Day economy
- Boiler sequence control
- Weekly boiler rotation
- Pump overrun
- 2 Stage frost protection
- Pump exercise routine
- Holiday scheduling
- BST/GMT auto clock change
- Summer/Winter selection
- Alarms

**Options**

1. Fixed time start of HWS - see hot water applications (DS 2.044A)
2. Remote Auto/Summer/Heating On/Holiday selection switch
3. Additional Space sensor for averaging
4. Boiler return sensor for frost protection
5. DST1601, DST1603 or DST0001 Strap on sensor available as an alternative to the DWT1701, DWT1702, DWT0001 or DWT0002 Immersion sensor

**Controller Connection Detail**

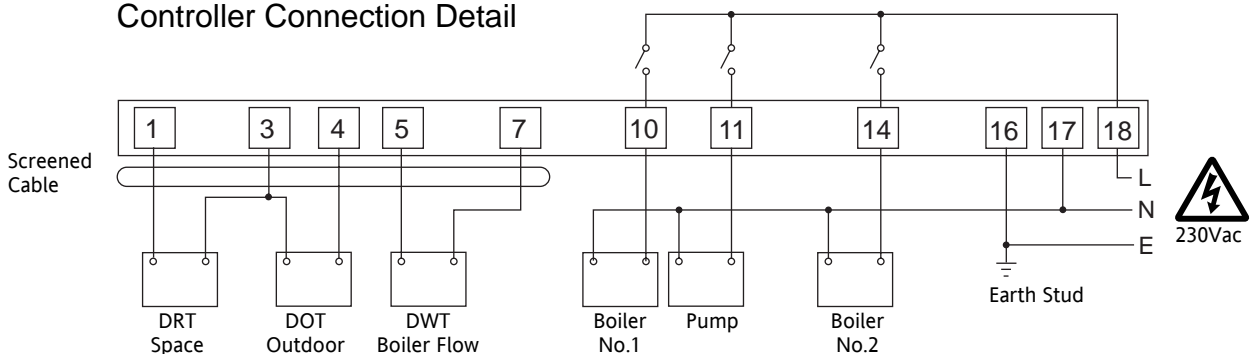

Sensor Screen Connections omitted for clarity

**WARNING - SEE SCHEMATIC DETAILS**

Note: Auxiliary relays/starters may be required if switching currents exceed 3A resistive, 1A inductive.

Refer to DS 2.044A for other applications.



**WARNING - ELECTRICAL SHOCK HAZARD.**  
 THIS CONTROLLER OPERATES FROM A 230Vac MAINS SUPPLY AND PROVIDES SWITCHED 230Vac OUTPUTS. ALWAYS ISOLATE THE MAINS SUPPLY FROM THE UNIT BEFORE REMOVING THE CONTROLLER FROM THE WIRING BASE.



**DIMENSION DETAILS**

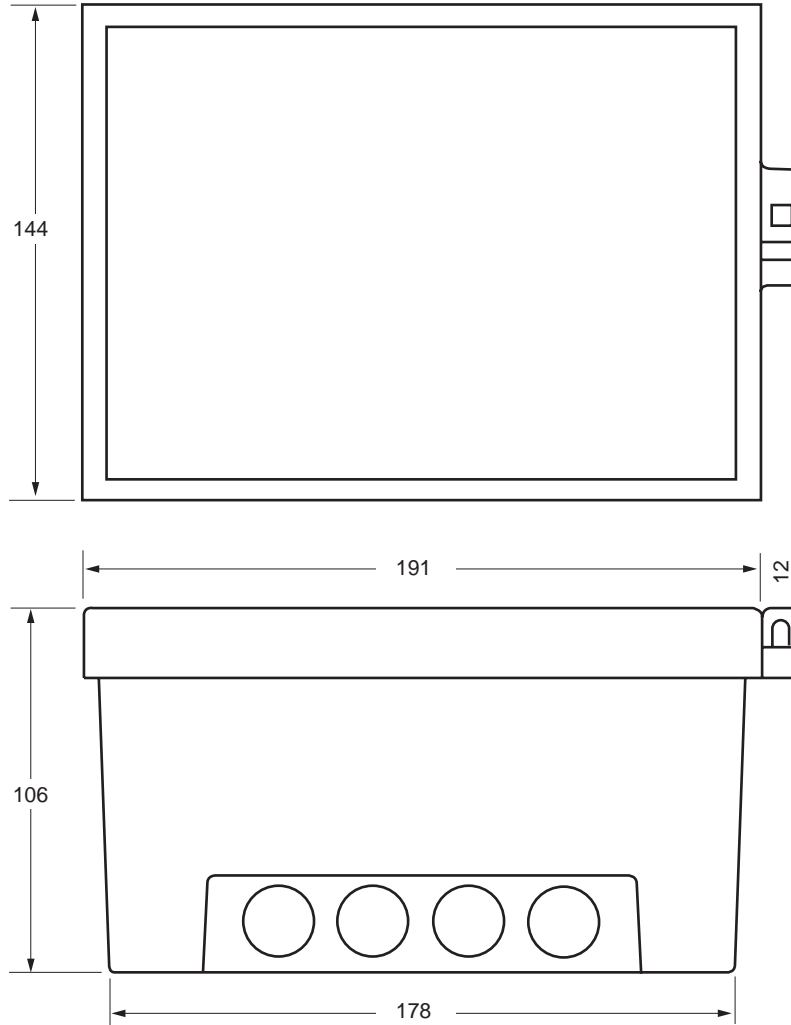

Dimensions in mm

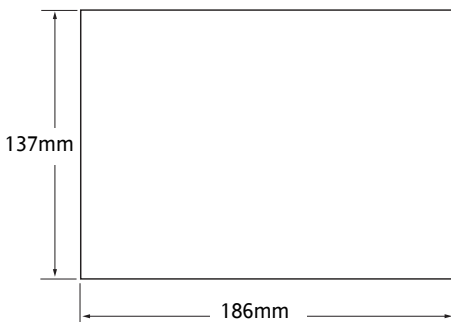

Panel Cut-out details.  
Allow 87mm depth.



**WARNINGS - ELECTRICAL SHOCK HAZARDS.**  
**THIS CONTROLLER OPERATES FROM A 230Vac MAINS SUPPLY AND PROVIDES SWITCHED 230Vac OUTPUTS. ALWAYS ISOLATE THE MAINS SUPPLY FROM THE UNIT BEFORE REMOVING THE CONTROLLER FROM THE WIRING BASE.**

**WARNING - THIS PRODUCT CONTAINS A NICKEL-METAL HYDRIDE BATTERY WHICH IS COMPLETELY SAFE WHILST IN NORMAL USE. THE BATTERY MUST BE DISPOSED OF IN AN AUTHORISED LANDFILL SITE.**

**Cautions**

- Do not apply any mains or other voltages until the wiring is complete and has been checked by a qualified technician.
- If any equipment covers have to be removed during the installation of this equipment, ensure that they are refitted after installation to comply with UL and CE safety requirements.
- Do not exceed maximum ambient temperature.
- Interference with parts under sealed covers invalidates guarantee.
- Design and performance of Satchwell equipment is subject to improvement and therefore liable to alteration without notice.
- Information is given for guidance only and Satchwell does not accept responsibility for the selection and installation of its products unless information has been given by the Company in writing relating to a specific application.
- A periodic system and tuning check of the control system is recommended. Please contact your local Satchwell office for details.

# Satchwell™

**Advanced Building Systems**  
**Satchwell Control Systems Ltd**  
 Farnham Road  
 Slough  
 Berkshire SL1 4UH  
 United Kingdom

Telephone +44 (0)1753 611000  
 Facsimile +44 (0)1753 611001  
 Web site www.satchwell.com

**An Invensys Controls Company**