

Single head system UC2000-30GM-E6R2-V15



Features

- Parameterisation interface for the application-specific adjustment of the sensor setting via the service program ULTRA 2001
- 2 switch outputs pnp, NO/NC
- 2 switching point free selectable
- hysteresis mode selectable
- Window function can be selected
- Synchronisation options
- adjustable acoustic power and sensitivity
- Temperature compensation
- Plug connection

Electrical connection

Standard symbol/Connection:

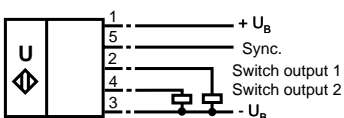

Dimensions

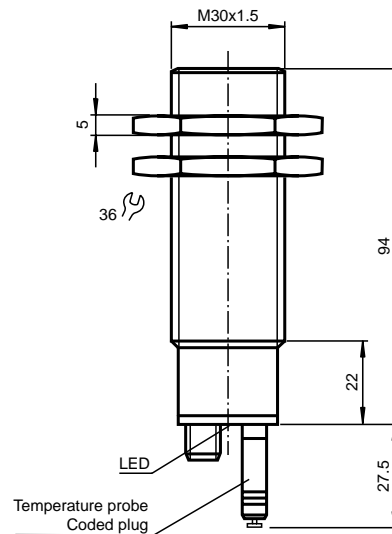

Technical data

General specifications

Sensing range	120 ... 2000 mm
Standard target plate	100 mm x 100 mm
Unusable area	0 ... 120 mm
Transducer frequency	approx. 180 kHz
Response delay	20 ms minimum 40 ms default settings
Standard conformity	EN 60947-5-2

Indicating/Operating means

LED green	permanent green: "Power-on", flashes during standby operation
LED yellow 1	switching state switch output 1
LED yellow 2	switching state switch output 2
LED red	red, flashing: "Error", (e.g. background noise level too high) (further functions see table)

Electrical specifications

Rated operational voltage U_e	10 ... 30 V DC, ripple 10 % _{SS}
No-load supply current I_0	≤ 50 mA

Interface

Interface type	RS 232, 9600 bit/s, no parity, 8 data bits, 1 stop bit, halfduplex with hardware echo
----------------	---

Input/Output

Synchronisation	1 synchro input, bidirectional 0-level: $-U_B...+1V$; 1-level: $+4V...+U_B$ input impedance: $>12 \Omega$ synchronisation pulse: $\geq 100 \mu s$ synchronisation pulse interval: $\geq 2 ms$
-----------------	--

Output

Output type	2 switch outputs pnp, NO/NC
Rated operational current I_e	200 mA, short circuit/overload protected
Voltage drop U_d	≤ 2 V DC
Range hysteresis H	= 1 % of the adjusted operating range (default settings), programmable
Repeat accuracy	≤ 0,2 % of final value
Resolution	< 1 mm
Temperature influence	≤ 2 % of final value

Ambient conditions

Ambient temperature	-25 ... +70 °C (248 ... 343 K)
Storage temperature	-40 ... +85 °C (233 ... 358 K)

Mechanical specifications

Protection degree	IP65 according to EN 60529
Connection type	V15 connector (M12 x 1)

Material

Housing	PBT
Transducer	epoxy resin/hollow glass sphere mixture; polyurethane foam
Mass	140 g

102159_e

25.07.2001

Note

Temperature-/TEACH-IN plug:

This ultrasonic sensor features a four-pole temperature/TEACH-IN plug that can be connected in four different positions. These have the following significance which are described in the this table.

Plug position	Function
A1	Teach switching point A1
A2	Teach switching point A2
E2/E3	Switching: 2 independent switching points/window mode/hysteresis mode
T	Normal mode with temperature compensation

Description of the teach-in procedure with temperature-/teach-in plug:

TEACH-IN of switching points 1 and 2:

- Cut supply voltage
- Remove temperature plug
- Restore supply voltage (Reset)
- Set object to desired switching point
- Connect TEACH-IN plug in pos. A1 or A2. Switching point 1 or A2 is taught.
- The TEACH-IN procedure is controlled with the LED. The green LED flashes, when object is detected, the red LED flashes when no object is detected.
- Connect TEACH-IN plug in pos. T. The TEACH-IN procedure is completed, the sensor is working in normal mode.

TEACH-In of the operation modes:

- Cut supply voltage
- Remove temperature plug
- Restore supply voltage (Reset)
- Connect TEACH-IN plug in pos. E2/E3. By multiple plugging, three different modes of operation can be set in cyclical sequence:
 - 1 switching point mode, LED A1 is flashing,
 - 2 window mode, LED A2 is flashing
 - 3 hysteresis mode, LED A1 and A2 are flashing
- Connect TEACH-IN plug in pos. T. The TEACH-IN procedure is completed, the sensor is working in normal mode.

Mode of operation

For the switch point setting the sensor has got two internal parameter sets. One parameter set contains the manually taught-in values for the switching distances and the mode of operation, the second parameter set contains switching distances and the mode of operation, which can be set via serial interface. The parameter set can be activated via the serial interface. The following operating modes can be set via the TEACH-IN procedure.

Modes of operation, which can be set via serial interface

Via serial interface the same modes of operation can be set as is the case with the manually TEACH-IN procedure. However, 2 switching points per switch output can be set. In window function and hysteresis mode different switch points can be selected for each switch output. Also, the mode of operation can be set separately for each switch output.

The sensor is programmed via RS 232 interface with the service program ULTRA 2001 (see accessories).

Synchronisation:

The sensor features a synchronisation input for the suppression of mutual interference. If this input is not used, the sensor will operate using an internally generated clock rate. It can be synchronised by applying a square wave voltage. A falling edge leads to the transmission of a single ultrasonic pulse. A low level ≥ 1 s or an open synchronisation input will result in the normal operation of the sensor. A high level > 1 s will result in the standby mode of the sensor (indicator green LED). Synchronisation cannot be performed during TEACH-IN and vice versa.

In synchronous mode a number of operation modes are possible:

Model number

UC2000-30GM-E6R2-V15

Characteristic curves/ Additional information

Characteristic response curves

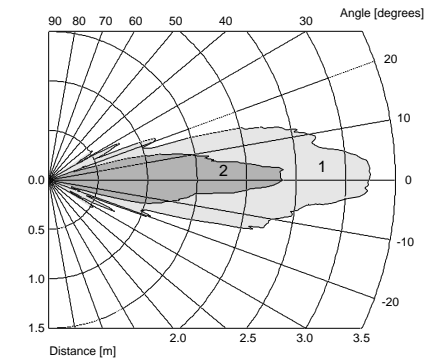

Curve 1: flat plate 100 mm x 100 mm
Curve 2: round bar, Ø 25 mm

Possible operating modes

1. Switch point mode

When $TA1 < TA2$, both switch outputs are activated as N.O. contacts.

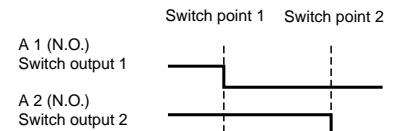

When $TA1 > TA2$, both switch outputs are activated as N.C. contacts.

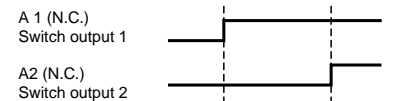

2. Window mode

To exchange the switching distances is of no effect.

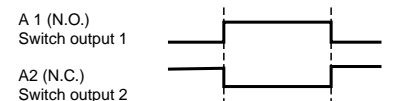

3. Hysteresis mode

To exchange the switching distances is of no effect.

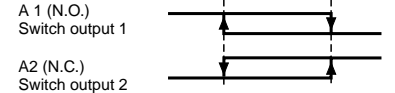

LED-Window

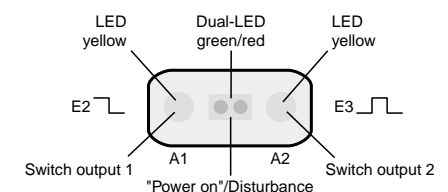

1. Two to five sensors can be synchronised by interconnecting their synchronisation inputs. In this case, the sensors alternately transmit ultrasonic pulses.
2. Multiple sensors can be controlled by the same synchronisation signal. The sensors are synchronised.
3. The synchronisation pulses are sent cyclically to individual sensors. The sensors operate in multiplex mode.
4. A high level at the synchronisation input disables the sensor.

The response time increases when the sensor is synchronised, because the measurement cycle time is increased by the synchronisation.

LED Displays

Displays in dependence on operating mode	Dual LED green	LED red	LED yellow A1	LED yellow A2
TEACH-IN of switching point A1 object detected no object detected	flashing OFF	OFF flashing	flashing flashing	OFF OFF
TEACH-IN switching point A2 object detected no object detected	flashing OFF	OFF flashing	OFF OFF	flashing flashing
TEACH-IN mode of operation (E2/E3) two independent switching points window mode Hysteresis mode	ON ON ON	OFF OFF OFF	flashing OFF flashing	OFF flashing flashing
Normal mode, temperature compensated	On	Off	Switching state A1	Switching state A2
Plug pulled or shorted	Off	On	Switching state A1	Switching state A2
Interference (e.g. compressed air)	Off	Flashing	last or defined condition	last or defined condition
Standby	Flashing	Off	Previous state	Previous state

LED ON indicates closed switch output

RS 232-connection

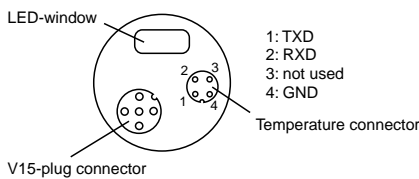

The following parameters are adjustable via the program ULTRA 2001 :

- Switching point 1 and 2
- NO- / NC function
- Mode of operation
- Sonic speed
- Temperature offset (The inherent temperature-rise of the sensor can be considered in the temperature compensation)
- Expansion of the blind area (for suppression of blind range echos)
- Reduction of the detection range (for suppression of remote range echos)
- Time of measuring cycle
- Acoustic power (interference of the burst duration)
- Sensitivity
- Behavior of the sensor in case of echo loss
- Behavior of the sensor in case of a fault
- Average formation via an allowed number of measuring cycles
- ON- /Off-delay
- Switching hysteresis
- Selection of the parameter set, RS232 or manual.

