

### Pin Definition:

1. Base
2. Collector
3. Emitter

### PRODUCT SUMMARY

$BV_{CEO}$	420V
$BV_{CBO}$	1050V
$I_C$	5A
$V_{CE(SAT)}$	0.5V @ $I_C=1A, I_B=0.2A$

### Features

- High Voltage Capability
- High Switching Speed

### Structure

- Silicon Triple Diffused Type
- NPN Silicon Transistor

### Ordering Information

Part No.	Package	Packing
TSC742CZ C0	TO-220	50pcs / Tube

### Block Diagram

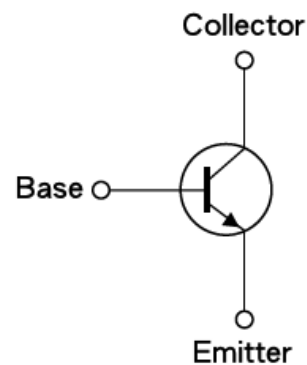

### Absolute Maximum Rating ( $T_A = 25^\circ\text{C}$ , unless otherwise noted)

Parameter	Symbol	Limit	Unit
Collector-Base Voltage	$V_{CBO}$	1050	V
Collector-Emitter Voltage @ $V_{BE}=0V$	$V_{CES}$	420	V
Emitter-Base Voltage	$V_{EBO}$	15	V
Collector Current	$I_C$	5	A
Collector Peak Current ( $t_p < 5ms$ )	$I_{CM}$	8	A
Base Current	$I_B$	2	A
Base Peak Current ( $t_p < 5ms$ )	$I_{BM}$	4	A
Power Total Dissipation @ $T_c=25^\circ\text{C}$	$P_{DTOT}$	70	W
Maximum Operating Junction Temperature	$T_J$	+150	$^\circ\text{C}$
Storage Temperature Range	$T_{STG}$	-55 to +150	$^\circ\text{C}$

**Note:** Single Pulse.  $P_W = 300\mu s$ , Duty  $\leq 2\%$

### Thermal Performance

Parameter	Symbol	Limit	Unit
Thermal Resistance - Junction to Case	$R_{\theta_{JC}}$	1.8	$^\circ\text{C/W}$
Thermal Resistance - Junction to Ambient	$R_{\theta_{JA}}$	62.5	$^\circ\text{C/W}$

### Electrical Specifications ( $T_A = 25^\circ\text{C}$ unless otherwise noted)

Parameter	Conditions	Symbol	Min	Typ	Max	Unit
<b>Static</b>						
Collector-Base Voltage	$I_C = 0.5\text{mA}$	$BV_{CBO}$	1050	--	--	V
Collector-Emitter Breakdown Voltage	$I_C = 5\text{mA}$	$BV_{CEO}$	420	--	--	V
Emitter-Base Breakdown Voltage	$I_E = 1\text{mA}$	$BV_{EBO}$	15	--	--	V
Collector Cutoff Current	$V_{CE} = 400\text{V}, I_B = 0$	$I_{CEO}$	--	10	250	$\mu\text{A}$
Collector Cutoff Current	$V_{CB} = 950\text{V}, I_E = 0$	$I_{CBO}$	--	--	10	$\mu\text{A}$
Collector-Emitter Saturation Voltage	$I_C = 1\text{A}, I_B = 0.2\text{A}$	$V_{CE(SAT)1}$	---	0.15	0.5	V
Collector-Emitter Saturation Voltage	$I_C = 3.5\text{A}, I_B = 1\text{A}$	$V_{CE(SAT)2}$	---	1.2	1.5	V
Base-Emitter Saturation Voltage	$I_C = 3.5\text{A}, I_B = 1\text{A}$	$V_{BE(SAT)1}$	--	1.0	1.5	V
DC Current Gain	$V_{CE} = 5\text{V}, I_C = 0.1\text{A}$	$h_{FE}$	48	70	100	
	$V_{CE} = 3\text{V}, I_C = 0.8\text{A}$		23	28	50	
<b>Resistive Load Switching Time (Ratings)</b>						
Rise Time	$V_{CC} = 5\text{V}, I_C = 0.5\text{A},$ $t_P = 300\mu\text{s},$	$t_r$	--	--	1	$\mu\text{s}$
Storage Time		$t_{STG}$	4.5	5	5.5	$\mu\text{s}$
Fall Time		$t_f$	--	--	1.2	$\mu\text{s}$

**Note:** Pulsed duration  $\leq 380\mu\text{s}$ , duty cycle  $\leq 2\%$

**TO-220 Mechanical Drawing**

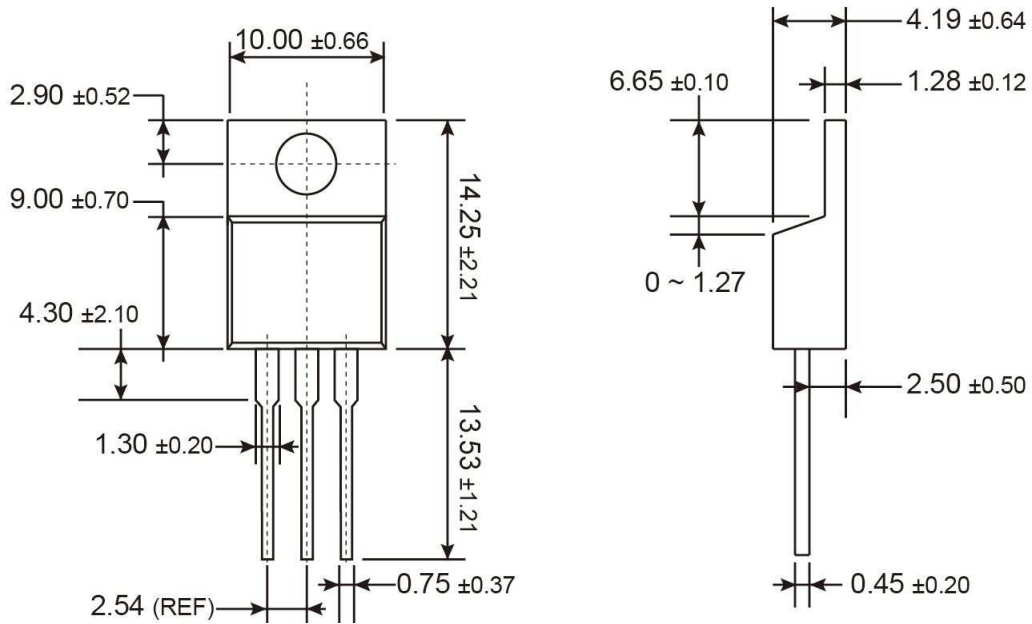

Unit: Millimeters

**Marking Diagram**

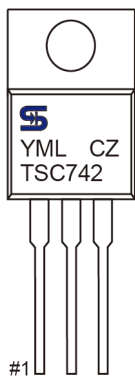

- Y** = Year Code
- M** = Month Code  
(**A**=Jan, **B**=Feb, **C**=Mar, **D**=Apr, **E**=May, **F**=Jun, **G**=Jul, **H**=Aug, **I**=Sep, **J**=Oct, **K**=Nov, **L**=Dec)
- L** = Lot Code

### Notice

Specifications of the products displayed herein are subject to change without notice. TSC or anyone on its behalf, assumes no responsibility or liability for any errors or inaccuracies.

Information contained herein is intended to provide a product description only. No license, express or implied, to any intellectual property rights is granted by this document. Except as provided in TSC's terms and conditions of sale for such products, TSC assumes no liability whatsoever, and disclaims any express or implied warranty, relating to sale and/or use of TSC products including liability or warranties relating to fitness for a particular purpose, merchantability, or infringement of any patent, copyright, or other intellectual property right.

The products shown herein are not designed for use in medical, life-saving, or life-sustaining applications. Customers using or selling these products for use in such applications do so at their own risk and agree to fully indemnify TSC for any damages resulting from such improper use or sale.