



# M24C32-W M24C32-R M24C32-F

## 32 Kbit serial I<sup>2</sup>C bus EEPROM

### Features

- Supports the I<sup>2</sup>C bus modes:
  - 400 kHz Fast-mode
  - 100 kHz Standard-mode
- Single supply voltages:
  - 2.5 V to 5.5 V (M24C32-W)
  - 1.8 V to 5.5 V (M24C32-R)
  - 1.7 V to 5.5 V (M24C32-F)
- Write Control input
- Byte and Page Write
- Random and Sequential Read modes
- Self-timed programming cycle
- Automatic address incrementing
- Enhanced ESD/latch-up protection
- More than 1 Million write cycles
- More than 40-year data retention
- Packages
  - SO8, TSSOP8, UDFPN8 packages:  
ECOPACK2<sup>®</sup> (RoHS-compliant and Halogen-free)
  - PDIP8 package:  
ECOPACK1<sup>®</sup> (RoHS-compliant)

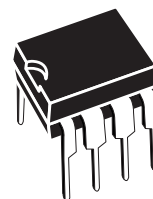

PDIP8 (BN)



SO8 (MN)  
150 mil width

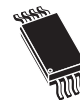

TSSOP8 (DW)  
169 mil width



UDFPN8 (MB)  
2 × 3 mm (MLP)

# Contents

<b>1</b>	<b>Description</b> .....	<b>6</b>
<b>2</b>	<b>Signal description</b> .....	<b>8</b>
2.1	Serial Clock (SCL) .....	8
2.2	Serial Data (SDA) .....	8
2.3	Chip Enable (E0, E1, E2) .....	8
2.4	Write Control ( $\overline{WC}$ ) .....	8
2.5	V <sub>SS</sub> ground .....	9
2.6	Supply voltage (V <sub>CC</sub> ) .....	9
2.6.1	Operating supply voltage V <sub>CC</sub> .....	9
2.6.2	Power-up conditions .....	9
2.6.3	Device reset .....	9
2.6.4	Power-down conditions .....	9
<b>3</b>	<b>Memory organization</b> .....	<b>12</b>
<b>4</b>	<b>Device operation</b> .....	<b>13</b>
4.1	Start condition .....	13
4.2	Stop condition .....	13
4.3	Acknowledge bit (ACK) .....	13
4.4	Data Input .....	13
4.5	Memory addressing .....	14
4.6	Write operations .....	16
4.7	Byte Write .....	16
4.8	Page Write .....	16
4.9	Minimizing system delays by polling on ACK .....	18
4.10	Read operations .....	20
4.11	Random Address Read .....	20
4.12	Current Address Read .....	20
4.13	Sequential Read .....	20
4.14	Acknowledge in Read mode .....	20

---

5	<b>Initial delivery state</b> .....	<b>21</b>
6	<b>Maximum rating</b> .....	<b>21</b>
7	<b>DC and AC parameters</b> .....	<b>22</b>
8	<b>Package mechanical data</b> .....	<b>28</b>
9	<b>Part numbering</b> .....	<b>32</b>
10	<b>Revision history</b> .....	<b>34</b>

## List of tables

Table 1.	Signal names . . . . .	7
Table 2.	Device select code . . . . .	11
Table 3.	Address most significant byte . . . . .	11
Table 4.	Address least significant byte . . . . .	11
Table 5.	Operating modes . . . . .	14
Table 6.	Absolute maximum ratings . . . . .	21
Table 7.	Operating conditions (M24xxx-W) . . . . .	22
Table 8.	Operating conditions (M24xxx-R) . . . . .	22
Table 9.	Operating conditions (M24xxx-F) . . . . .	22
Table 10.	AC test measurement conditions . . . . .	22
Table 11.	Input parameters . . . . .	23
Table 12.	DC characteristics (M24xxx-W, device grade 6) . . . . .	23
Table 13.	DC characteristics (M24xxx-W, device grade 3) . . . . .	24
Table 14.	DC characteristics (M24xxx-R - device grade 6) . . . . .	24
Table 15.	DC characteristics (M24xxx-F) . . . . .	25
Table 16.	AC characteristics . . . . .	26
Table 17.	PDIP8 – 8 pin plastic DIP, 0.25 mm lead frame, package mechanical data . . . . .	28
Table 18.	SO8 narrow – 8 lead plastic small outline, 150 mils body width, package mechanical data . . . . .	29
Table 19.	TSSOP8 – 8 lead thin shrink small outline, package mechanical data . . . . .	30
Table 20.	UFDFPN8 (MLP8) – 8-lead ultra thin fine pitch dual flat package no lead 2 × 3mm, package mechanical data . . . . .	31
Table 21.	Ordering information scheme . . . . .	32
Table 22.	Available M24C32 products (package, voltage range, temperature grade) . . . . .	33
Table 23.	Document revision history . . . . .	34

## List of figures

Figure 1.	Logic diagram . . . . .	6
Figure 2.	DIP, SO, TSSOP and UDFPN connections . . . . .	7
Figure 3.	Device select code . . . . .	8
Figure 4.	Maximum $R_P$ value versus bus parasitic capacitance (C) for an I <sup>2</sup> C bus . . . . .	10
Figure 5.	I <sup>2</sup> C bus protocol . . . . .	10
Figure 6.	Block diagram . . . . .	12
Figure 7.	Write mode sequences with $\overline{WC} = 1$ (data write inhibited) . . . . .	15
Figure 8.	Write mode sequences with $\overline{WC} = 0$ (data write enabled) . . . . .	17
Figure 9.	Write cycle polling flowchart using ACK . . . . .	18
Figure 10.	Read mode sequences . . . . .	19
Figure 11.	AC test measurement I/O waveform . . . . .	23
Figure 12.	AC waveforms . . . . .	27
Figure 13.	PDIP8 – 8 pin plastic DIP, 0.25 mm lead frame, package outline . . . . .	28
Figure 14.	SO8 narrow – 8 lead plastic small outline, 150 mils body width, package outline . . . . .	29
Figure 15.	TSSOP8 – 8 lead thin shrink small outline, package outline . . . . .	30
Figure 16.	UDFPN8 (MLP8) – 8-lead ultra thin fine pitch dual flat package no lead 2 × 3mm, package outline. . . . .	31

# 1 Description

The M24C32-W, M24C32-R and M24C32-F devices are I<sup>2</sup>C-compatible electrically erasable programmable memories (EEPROM). They are organized as 4096 × 8 bits.

**Figure 1. Logic diagram**

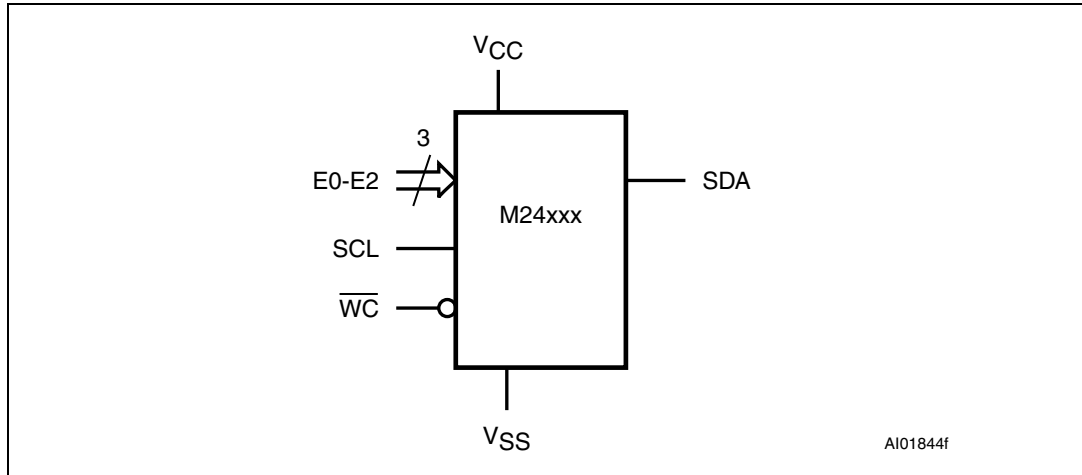

I<sup>2</sup>C uses a two-wire serial interface, comprising a bidirectional data line and a clock line. The devices carry a built-in 4-bit device type identifier code (1010) in accordance with the I<sup>2</sup>C bus definition.

The device behaves as a slave in the I<sup>2</sup>C protocol, with all memory operations synchronized by the serial clock. Read and Write operations are initiated by a Start condition, generated by the bus master. The Start condition is followed by a device select code and Read/Write bit ( $\overline{RW}$ ) (as described in [Table 2](#)), terminated by an acknowledge bit.

When writing data to the memory, the device inserts an acknowledge bit during the 9<sup>th</sup> bit time, following the bus master's 8-bit transmission. When data is read by the bus master, the bus master acknowledges the receipt of the data byte in the same way. Data transfers are terminated by a Stop condition after an Ack for Write, and after a NoAck for Read.

**Table 1. Signal names**

Signal name	Function	Direction
E0, E1, E2	Chip Enable	Input
SDA	Serial Data	I/O
SCL	Serial Clock	Input
WC	Write Control	Input
V <sub>CC</sub>	Supply voltage	
V <sub>SS</sub>	Ground	

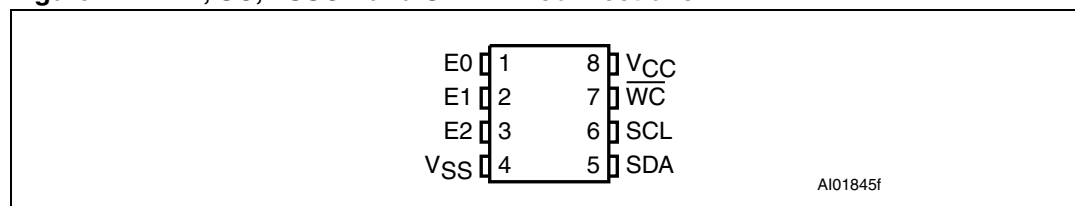
**Figure 2. DIP, SO, TSSOP and UDFPN connections**

1. See [Package mechanical data](#) section for package dimensions, and how to identify pin-1.

## 2 Signal description

### 2.1 Serial Clock (SCL)

This input signal is used to strobe all data in and out of the device. In applications where this signal is used by slave devices to synchronize the bus to a slower clock, the bus master must have an open drain output, and a pull-up resistor must be connected from Serial Clock (SCL) to  $V_{CC}$ . (*Figure 4* indicates how the value of the pull-up resistor can be calculated). In most applications, though, this method of synchronization is not employed, and so the pull-up resistor is not necessary, provided that the bus master has a push-pull (rather than open drain) output.

### 2.2 Serial Data (SDA)

This bidirectional signal is used to transfer data in or out of the device. It is an open drain output that may be wire-OR'ed with other open drain or open collector signals on the bus. A pull up resistor must be connected from Serial Data (SDA) to  $V_{CC}$ . (*Figure 4* indicates how the value of the pull-up resistor can be calculated).

### 2.3 Chip Enable (E0, E1, E2)

These input signals are used to set the value that is to be looked for on the three least significant bits (b3, b2, b1) of the 7-bit device select code. These inputs must be tied to  $V_{CC}$  or  $V_{SS}$ , to establish the device select code as shown in *Figure 3*. When not connected (left floating), these inputs are read as low (0,0,0).

**Figure 3. Device select code**

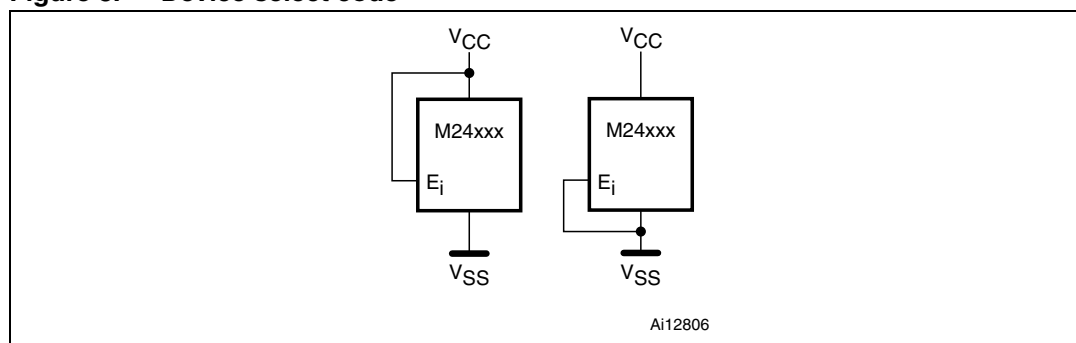

### 2.4 Write Control ( $\overline{WC}$ )

This input signal is useful for protecting the entire contents of the memory from inadvertent write operations. Write operations are disabled to the entire memory array when Write Control ( $\overline{WC}$ ) is driven high. When unconnected, the signal is internally read as  $V_{IL}$ , and Write operations are allowed.

When Write Control ( $\overline{WC}$ ) is driven high, device select and Address bytes are acknowledged, Data bytes are not acknowledged.

## 2.5 $V_{SS}$ ground

$V_{SS}$  is the reference for the  $V_{CC}$  supply voltage.

## 2.6 Supply voltage ( $V_{CC}$ )

### 2.6.1 Operating supply voltage $V_{CC}$

Prior to selecting the memory and issuing instructions to it, a valid and stable  $V_{CC}$  voltage within the specified [ $V_{CC}(\min)$ ,  $V_{CC}(\max)$ ] range must be applied (see [Table 7](#), [Table 8](#) and [Table 9](#)). In order to secure a stable DC supply voltage, it is recommended to decouple the  $V_{CC}$  line with a suitable capacitor (usually of the order of 10 nF to 100 nF) close to the  $V_{CC}/V_{SS}$  package pins.

This voltage must remain stable and valid until the end of the transmission of the instruction and, for a Write instruction, until the completion of the internal write cycle ( $t_W$ ).

### 2.6.2 Power-up conditions

The  $V_{CC}$  voltage has to rise continuously from 0 V up to the minimum  $V_{CC}$  operating voltage defined in [Table 7](#), [Table 8](#) and [Table 9](#). The rise time must not vary faster than 1 V/ $\mu$ s.

### 2.6.3 Device reset

In order to prevent inadvertent Write operations during power-up, a power on reset (POR) circuit is included. At power-up (continuous rise of  $V_{CC}$ ), the device does not respond to any instruction until  $V_{CC}$  has reached the power on reset threshold voltage (this threshold is lower than the minimum  $V_{CC}$  operating voltage defined in [Table 8](#) and [Table 9](#)). Until  $V_{CC}$  passes over the POR threshold, the device is reset and in Standby Power mode.

In a similar way, during power-down (continuous decay of  $V_{CC}$ ), as soon as  $V_{CC}$  drops below the POR threshold voltage, the device is reset and stops responding to any instruction sent to it.

### 2.6.4 Power-down conditions

During power-down (continuous decay of  $V_{CC}$ ), the device must be in Standby Power mode (mode reached after decoding a Stop condition, assuming that there is no internal Write cycle in progress).

**Figure 4. Maximum  $R_p$  value versus bus parasitic capacitance (C) for an I<sup>2</sup>C bus**

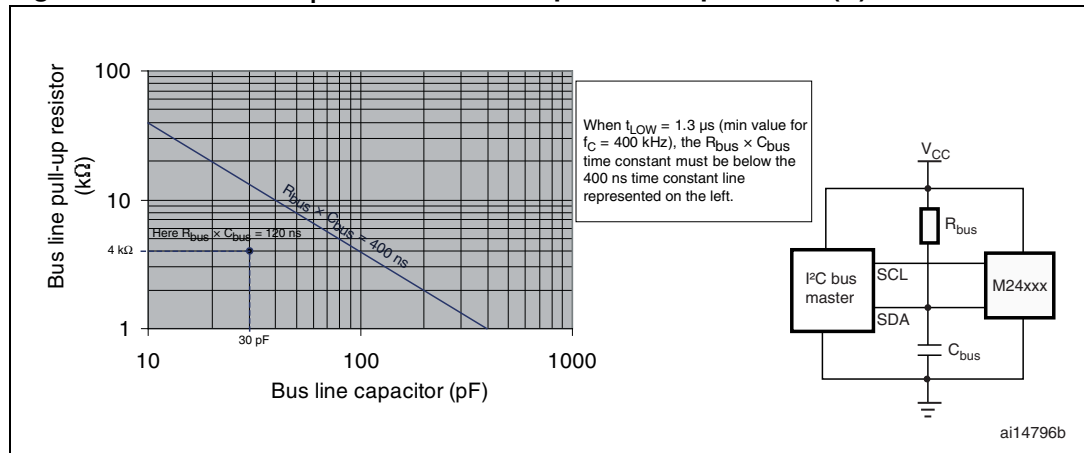

**Figure 5. I<sup>2</sup>C bus protocol**

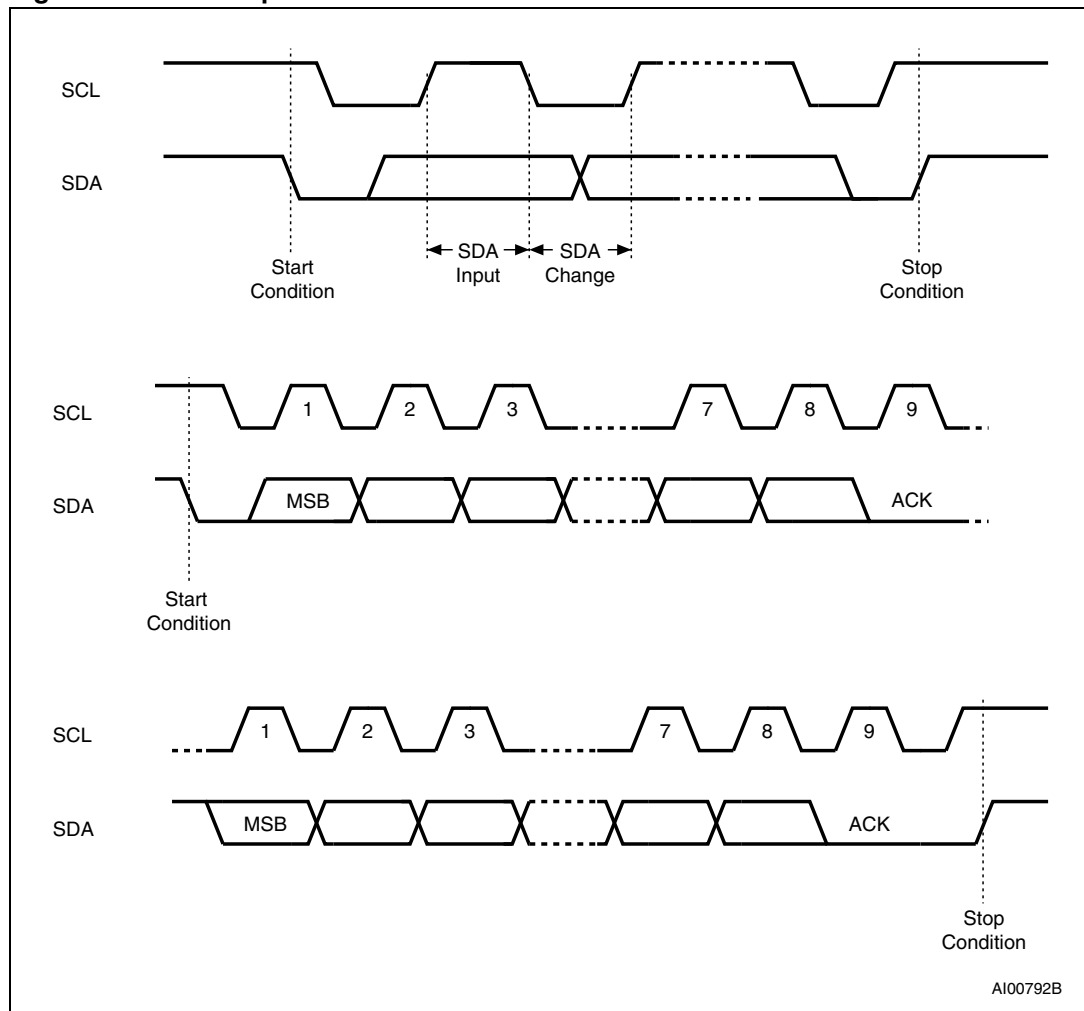

**Table 2. Device select code**

	Device type identifier <sup>(1)</sup>				Chip Enable address <sup>(2)</sup>			R $\overline{W}$
	b7	b6	b5	b4	b3	b2	b1	b0
Device select code	1	0	1	0	E2	E1	E0	R $\overline{W}$

1. The most significant bit, b7, is sent first.

2. E0, E1 and E2 are compared against the respective external pins on the memory device.

**Table 3. Address most significant byte**

b15	b14	b13	b12	b11	b10	b9	b8
-----	-----	-----	-----	-----	-----	----	----

**Table 4. Address least significant byte**

b7	b6	b5	b4	b3	b2	b1	b0
----	----	----	----	----	----	----	----

### 3 Memory organization

The memory is organized as shown in *Figure 6*.

**Figure 6. Block diagram**

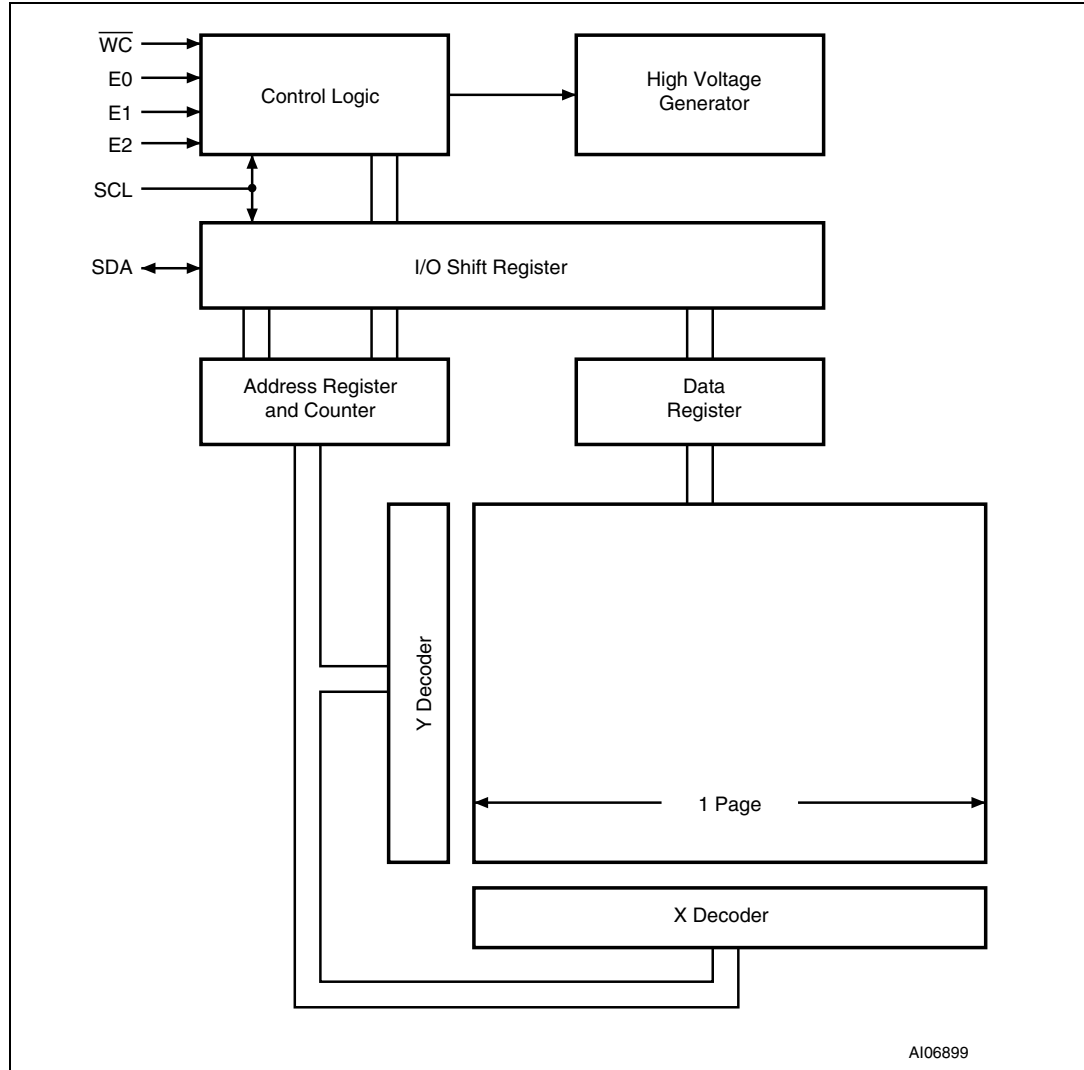

## 4 Device operation

The device supports the I<sup>2</sup>C protocol. This is summarized in [Figure 5](#). Any device that sends data on to the bus is defined to be a transmitter, and any device that reads the data to be a receiver. The device that controls the data transfer is known as the bus master, and the other as the slave device. A data transfer can only be initiated by the bus master, which will also provide the serial clock for synchronization. The device is always a slave in all communications.

### 4.1 Start condition

Start is identified by a falling edge of Serial Data (SDA) while Serial Clock (SCL) is stable in the high state. A Start condition must precede any data transfer command. The device continuously monitors (except during a Write cycle) Serial Data (SDA) and Serial Clock (SCL) for a Start condition, and will not respond unless one is given.

### 4.2 Stop condition

Stop is identified by a rising edge of Serial Data (SDA) while Serial Clock (SCL) is stable and driven high. A Stop condition terminates communication between the device and the bus master. A Read command that is followed by NoAck can be followed by a Stop condition to force the device into the Standby mode. A Stop condition at the end of a Write command triggers the internal Write cycle.

### 4.3 Acknowledge bit (ACK)

The acknowledge bit is used to indicate a successful byte transfer. The bus transmitter, whether it be bus master or slave device, releases Serial Data (SDA) after sending eight bits of data. During the 9<sup>th</sup> clock pulse period, the receiver pulls Serial Data (SDA) low to acknowledge the receipt of the eight data bits.

### 4.4 Data Input

During data input, the device samples Serial Data (SDA) on the rising edge of Serial Clock (SCL). For correct device operation, Serial Data (SDA) must be stable during the rising edge of Serial Clock (SCL), and the Serial Data (SDA) signal must change *only* when Serial Clock (SCL) is driven low.

## 4.5 Memory addressing

To start communication between the bus master and the slave device, the bus master must initiate a Start condition. Following this, the bus master sends the device select code, shown in [Table 2](#) (on Serial Data (SDA), most significant bit first).

The device select code consists of a 4-bit device type identifier, and a 3-bit Chip Enable "Address" (E2, E1, E0). To address the memory array, the 4-bit device type identifier is 1010b.

Up to eight memory devices can be connected on a single I<sup>2</sup>C bus. Each one is given a unique 3-bit code on the Chip Enable (E0, E1, E2) inputs. When the device select code is received, the device only responds if the Chip Enable Address is the same as the value on the Chip Enable (E0, E1, E2) inputs.

The 8<sup>th</sup> bit is the Read/Write bit ( $\overline{RW}$ ). This bit is set to 1 for Read and 0 for Write operations.

If a match occurs on the device select code, the corresponding device gives an acknowledgment on Serial Data (SDA) during the 9<sup>th</sup> bit time. If the device does not match the device select code, it deselects itself from the bus, and goes into Standby mode.

**Table 5. Operating modes**

Mode	$\overline{RW}$ bit	$\overline{WC}^{(1)}$	Bytes	Initial sequence
Current Address Read	1	X	1	Start, device select, $\overline{RW} = 1$
Random Address Read	0	X	1	Start, device select, $\overline{RW} = 0$ , Address
	1	X		reStart, device select, $\overline{RW} = 1$
Sequential Read	1	X	$\geq 1$	Similar to Current or Random Address Read
Byte Write	0	$V_{IL}$	1	Start, device select, $\overline{RW} = 0$
Page Write	0	$V_{IL}$	$\leq 32$	Start, device select, $\overline{RW} = 0$

1. X =  $V_{IH}$  or  $V_{IL}$ .

Figure 7. Write mode sequences with  $\overline{WC} = 1$  (data write inhibited)

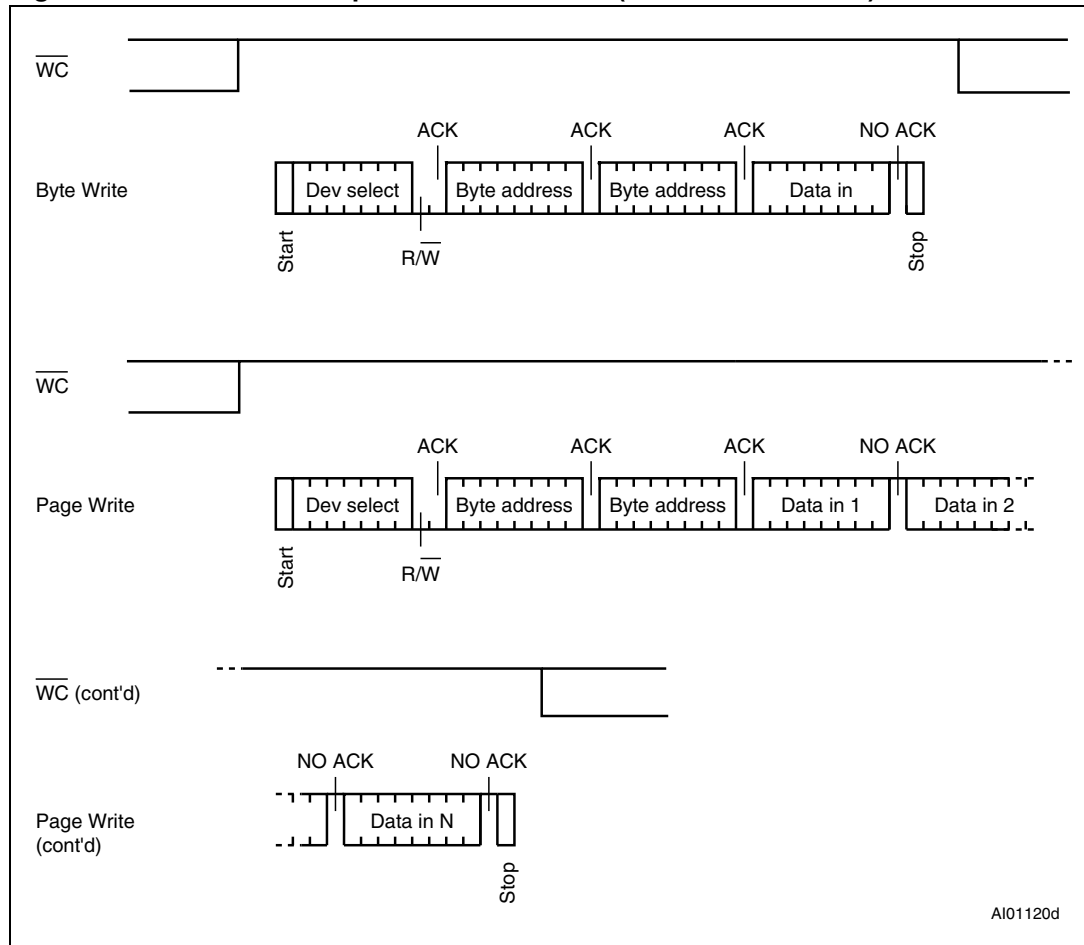

## 4.6 Write operations

Following a Start condition the bus master sends a device select code with the Read/Write bit (RW) reset to 0. The device acknowledges this, as shown in [Figure 8](#), and waits for two address bytes. The device responds to each address byte with an acknowledge bit, and then waits for the data Byte.

Writing to the memory may be inhibited if Write Control ( $\overline{WC}$ ) is driven high. Any Write instruction with Write Control ( $\overline{WC}$ ) driven high (during a period of time from the Start condition until the end of the two address bytes) will not modify the memory contents, and the accompanying data bytes are *not* acknowledged, as shown in [Figure 7](#).

Each data byte in the memory has a 16-bit (two byte wide) address. The Most Significant Byte ([Table 3](#)) is sent first, followed by the Least Significant Byte ([Table 4](#)). Bits b15 to b0 form the address of the byte in memory.

When the bus master generates a Stop condition immediately after the Ack bit (in the “10<sup>th</sup> bit” time slot), either at the end of a Byte Write or a Page Write, the internal Write cycle is triggered. A Stop condition at any other time slot does not trigger the internal Write cycle.

After the Stop condition, the delay  $t_W$ , and the successful completion of a Write operation, the device's internal address counter is incremented automatically, to point to the next byte address after the last one that was modified.

During the internal Write cycle, Serial Data (SDA) is disabled internally, and the device does not respond to any requests.

## 4.7 Byte Write

After the device select code and the address bytes, the bus master sends one data byte. If the addressed location is Write-protected, by Write Control ( $\overline{WC}$ ) being driven high, the device replies with NoAck, and the location is not modified. If, instead, the addressed location is not Write-protected, the device replies with Ack. The bus master terminates the transfer by generating a Stop condition, as shown in [Figure 8](#).

## 4.8 Page Write

The Page Write mode allows up to 32 bytes to be written in a single Write cycle, provided that they are all located in the same ‘row’ in the memory: that is, the most significant memory address bits (b11-b5) are the same. If more bytes are sent than will fit up to the end of the row, a condition known as ‘roll-over’ occurs. This should be avoided, as data starts to become overwritten in an implementation dependent way.

The bus master sends from 1 to 32 bytes of data, each of which is acknowledged by the device if Write Control ( $\overline{WC}$ ) is low. If Write Control ( $\overline{WC}$ ) is high, the contents of the addressed memory location are not modified, and each data byte is followed by a NoAck. After each byte is transferred, the internal byte address counter (inside the page) is incremented. The transfer is terminated by the bus master generating a Stop condition.

Figure 8. Write mode sequences with  $\overline{WC} = 0$  (data write enabled)

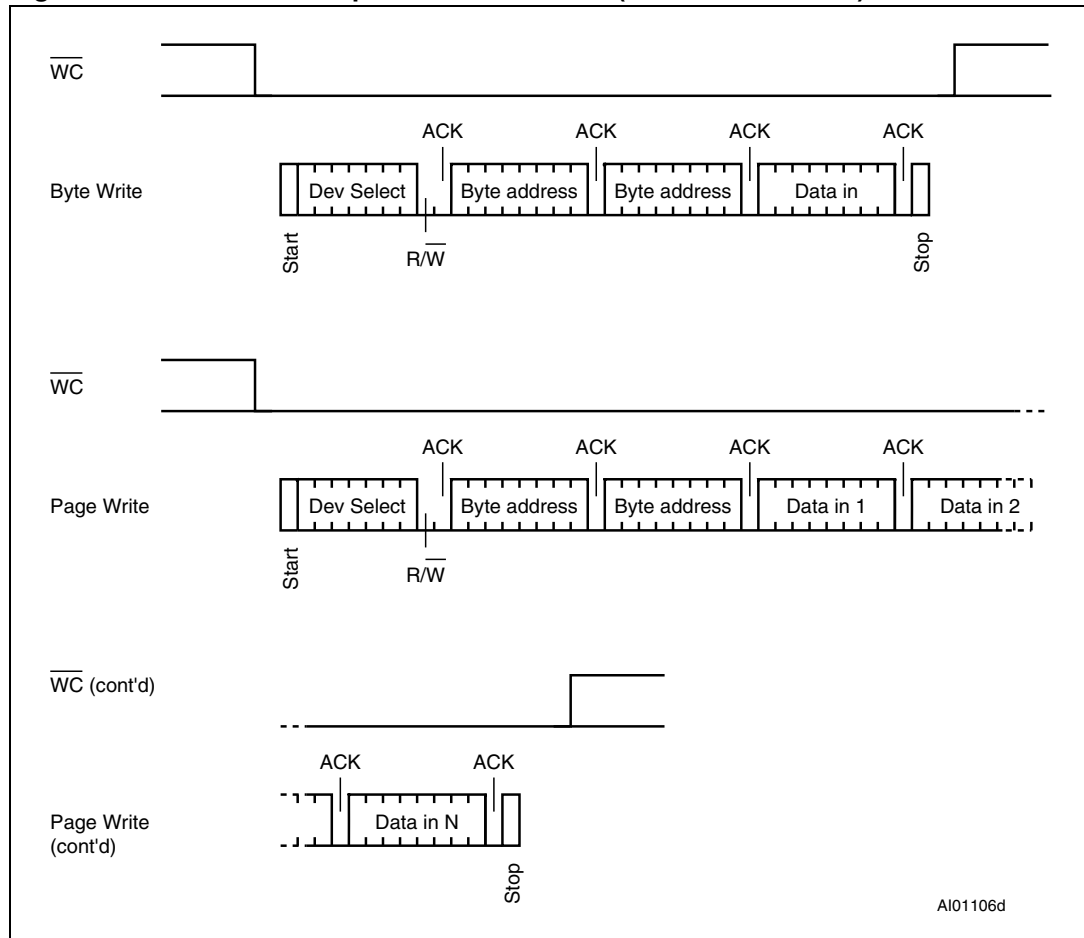

AI01106d

Figure 9. Write cycle polling flowchart using ACK

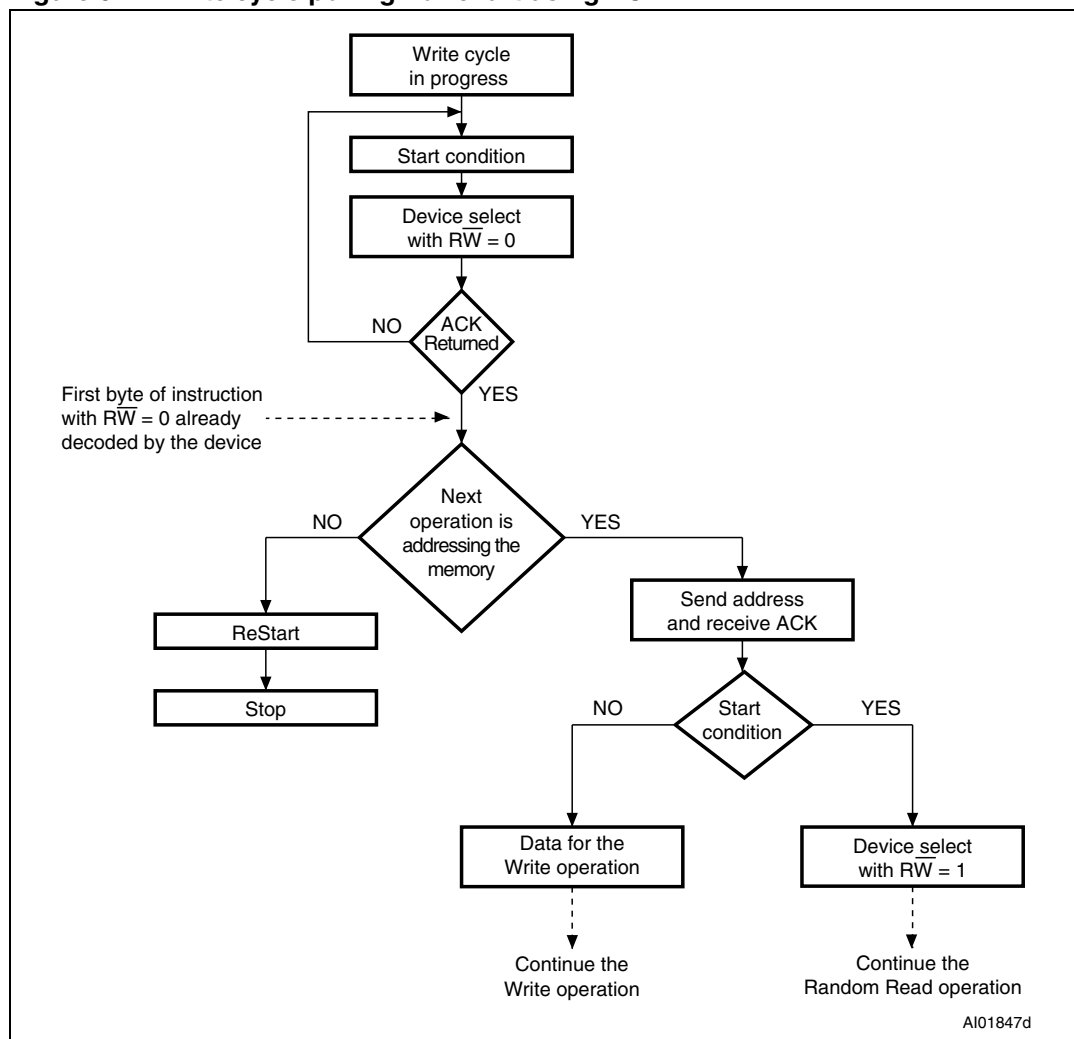

## 4.9 Minimizing system delays by polling on ACK

During the internal Write cycle, the device disconnects itself from the bus, and writes a copy of the data from its internal latches to the memory cells. The maximum Write time ( $t_w$ ) is shown in [Table 16](#), but the typical time is shorter. To make use of this, a polling sequence can be used by the bus master.

The sequence, as shown in [Figure 9](#), is:

1. Initial condition: a Write cycle is in progress.
2. Step 1: the bus master issues a Start condition followed by a device select code (the first byte of the new instruction).
3. Step 2: if the device is busy with the internal Write cycle, no Ack will be returned and the bus master goes back to Step 1. If the device has terminated the internal Write cycle, it responds with an Ack, indicating that the device is ready to receive the second part of the instruction (the first byte of this instruction having been sent during Step 1).

Figure 10. Read mode sequences

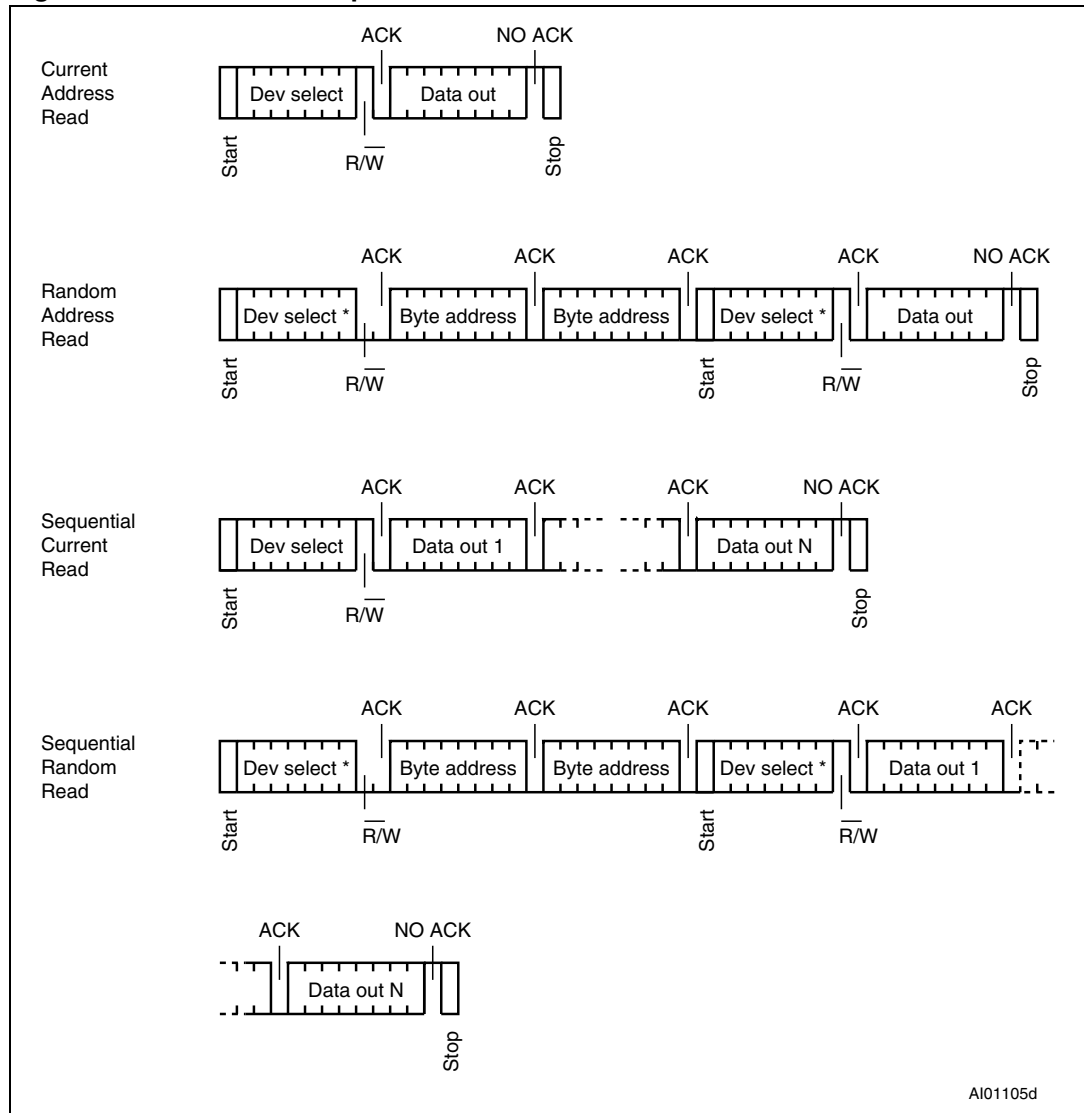

1. The seven most significant bits of the device select code of a Random Read (in the 1<sup>st</sup> and 4<sup>th</sup> bytes) must be identical.

## 4.10 Read operations

Read operations are performed independently of the state of the Write Control ( $\overline{WC}$ ) signal. After the successful completion of a Read operation, the device's internal address counter is incremented by one, to point to the next byte address.

## 4.11 Random Address Read

A dummy Write is first performed to load the address into this address counter (as shown in [Figure 10](#)) but *without* sending a Stop condition. Then, the bus master sends another Start condition, and repeats the device select code, with the Read/Write bit ( $\overline{RW}$ ) set to 1. The device acknowledges this, and outputs the contents of the addressed byte. The bus master must *not* acknowledge the byte, and terminates the transfer with a Stop condition.

## 4.12 Current Address Read

For the Current Address Read operation, following a Start condition, the bus master only sends a device select code with the Read/Write bit ( $\overline{RW}$ ) set to 1. The device acknowledges this, and outputs the byte addressed by the internal address counter. The counter is then incremented. The bus master terminates the transfer with a Stop condition, as shown in [Figure 10](#), *without* acknowledging the Byte.

## 4.13 Sequential Read

This operation can be used after a Current Address Read or a Random Address Read. The bus master *does* acknowledge the data byte output, and sends additional clock pulses so that the device continues to output the next byte in sequence. To terminate the stream of bytes, the bus master must *not* acknowledge the last byte, and *must* generate a Stop condition, as shown in [Figure 10](#).

The output data comes from consecutive addresses, with the internal address counter automatically incremented after each byte output. After the last memory address, the address counter 'rolls-over', and the device continues to output data from memory address 00h.

## 4.14 Acknowledge in Read mode

For all Read commands, the device waits, after each byte read, for an acknowledgment during the 9<sup>th</sup> bit time. If the bus master does not drive Serial Data (SDA) low during this time, the device terminates the data transfer and switches to its Standby mode.

## 5 Initial delivery state

The device is delivered with all bits in the memory array set to 1 (each byte contains FFh).

## 6 Maximum rating

Stressing the device outside the ratings listed in [Table 6](#) may cause permanent damage to the device. These are stress ratings only, and operation of the device at these, or any other conditions outside those indicated in the Operating sections of this specification, is not implied. Exposure to absolute maximum rating conditions for extended periods may affect device reliability. Refer also to the STMicroelectronics SURE Program and other relevant quality documents.

**Table 6. Absolute maximum ratings**

Symbol	Parameter	Min.	Max.	Unit
$T_A$	Ambient operating temperature	-40	130	°C
$T_{STG}$	Storage temperature	-65	150	°C
$T_{LEAD}$	Lead temperature during soldering	see note <sup>(1)</sup>		°C
	PDIP-specific lead temperature during soldering		260 <sup>(2)</sup>	°C
$V_{IO}$	Input or output range	-0.50	6.5	V
$I_{OL}$	DC output current (SDA = 0)	-	5	mA
$V_{CC}$	Supply voltage	-0.50	6.5	V
$V_{ESD}$	Electrostatic discharge voltage (human body model) <sup>(3)</sup>	-4000	4000	V

1. Compliant with JEDEC Std J-STD-020D (for small body, Sn-Pb or Pb assembly), the ST ECOPACK® 7191395 specification, and the European directive on Restrictions on Hazardous Substances (RoHS) 2002/95/EU.
2.  $T_{LEAD}$  max must not be applied for more than 10 s.
3. AEC-Q100-002 (compliant with JEDEC Std JESD22-A114A, C1=100pF, R1=1500 Ω, R2=500 Ω)

## 7 DC and AC parameters

This section summarizes the operating and measurement conditions, and the DC and AC characteristics of the device. The parameters in the DC and AC characteristic tables that follow are derived from tests performed under the measurement conditions summarized in the relevant tables. Designers should check that the operating conditions in their circuit match the measurement conditions when relying on the quoted parameters.

**Table 7. Operating conditions (M24xxx-W)**

Symbol	Parameter	Min.	Max.	Unit
$V_{CC}$	Supply voltage	2.5	5.5	V
$T_A$	Ambient operating temperature (device grade 6)	-40	85	°C
	Ambient operating temperature (device grade 3)	-40	125	°C

**Table 8. Operating conditions (M24xxx-R)**

Symbol	Parameter	Min.	Max.	Unit
$V_{CC}$	Supply voltage	1.8	5.5	V
$T_A$	Ambient operating temperature	-40	85	°C

**Table 9. Operating conditions (M24xxx-F)**

Symbol	Parameter	Min.	Max.	Unit
$V_{CC}$	Supply voltage	1.7	5.5	V
$T_A$	Ambient operating temperature (device grade 6)	-40	85	°C
	Ambient operating temperature (device grade 5)	-20	85	°C

**Table 10. AC test measurement conditions**

Symbol	Parameter	Min.	Max.	Unit
$C_L$	Load capacitance	100		pF
	Input rise and fall times		50	ns
	Input levels	0.2 $V_{CC}$ to 0.8 $V_{CC}$		V
	Input and output timing reference levels	0.3 $V_{CC}$ to 0.7 $V_{CC}$		V

Figure 11. AC test measurement I/O waveform

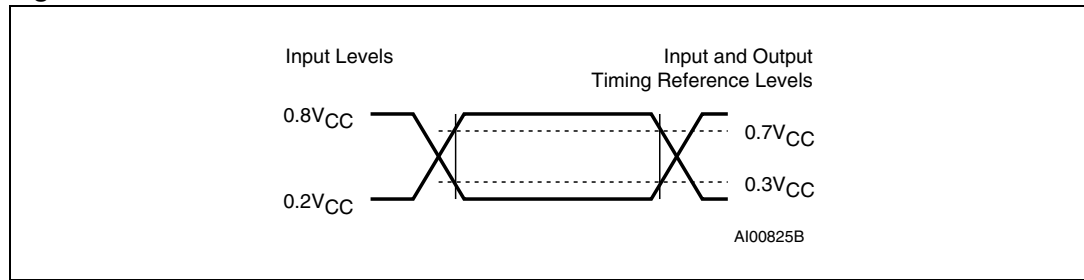

Table 11. Input parameters

Symbol	Parameter	Test condition	Min.	Max.	Unit
$C_{IN}$	Input capacitance (SDA)			8	pF
$C_{IN}$	Input capacitance (other pins)			6	pF
$Z_{WCL}^{(1)}$	$\overline{WC}$ input impedance	$V_{IN} < 0.3V_{CC}$	50	200	k $\Omega$
$Z_{WCH}^{(1)}$	$\overline{WC}$ input impedance	$V_{IN} > 0.7V_{CC}$	500		k $\Omega$
$t_{NS}^{(1)}$	Pulse width ignored (Input filter on SCL and SDA)			100	ns

1. Characterized only.

Table 12. DC characteristics (M24xxx-W, device grade 6)

Symbol	Parameter	Test condition (in addition to those in Table 7)	Min.	Max.	Unit
$I_{LI}$	Input leakage current (SCL, SDA, E2, E1, E0)	$V_{IN} = V_{SS}$ or $V_{CC}$ device in Standby mode		$\pm 2$	$\mu A$
$I_{LO}$	Output leakage current	SDA in Hi-Z, external voltage applied on SDA: $V_{SS}$ or $V_{CC}$		$\pm 2$	$\mu A$
$I_{CC}$	Supply current (Read)	$2.5 V < V_{CC} < 5.5 V$ , $f_c = 400 kHz$		2	mA
$I_{CC0}$	Supply current (Write)	During $t_W$ , $2.5 V < V_{CC} < 5.5 V$		5 <sup>(1)</sup>	mA
$I_{CC1}$	Standby supply current	Device not selected <sup>(2)</sup> , $V_{IN} = V_{SS}$ or $V_{CC}$ , $V_{CC} = 5.5 V$		5	$\mu A$
	Standby supply current	Device not selected <sup>(2)</sup> , $V_{IN} = V_{SS}$ or $V_{CC}$ , $V_{CC} = 2.5 V$		2	$\mu A$
$V_{IL}$	Input low voltage (SDA, SCL, $\overline{WC}$ )		-0.45	$0.3V_{CC}$	V
$V_{IH}$	Input high voltage (SCL, SDA)		$0.7V_{CC}$	6.5	V
	Input high voltage ( $\overline{WC}$ , E0, E1, E2)		$0.7V_{CC}$	$V_{CC}+0.6$	V
$V_{OL}$	Output low voltage	$I_{OL} = 2.1 mA$ , $V_{CC} = 2.5 V$ or $I_{OL} = 3 mA$ , $V_{CC} = 5.5 V$		0.4	V

1. Characterized value, not tested in production.

2. The device is not selected after power-up, after a Read command (after the Stop condition) or after the completion of the internal write cycle  $t_W$  ( $t_W$  is triggered by the correct decoding of a Write command).

Table 13. DC characteristics (M24xxx-W, device grade 3)

Symbol	Parameter	Test condition (in addition to those in Table 7)	Min.	Max.	Unit
$I_{LI}$	Input leakage current (SCL, SDA, E2, E1, E0)	$V_{IN} = V_{SS}$ or $V_{CC}$ device in Standby mode		$\pm 2$	$\mu A$
$I_{LO}$	Output leakage current	SDA in Hi-Z, external voltage applied on SDA: $V_{SS}$ or $V_{CC}$		$\pm 2$	$\mu A$
$I_{CC}$	Supply current (Read)	$2.5 V < V_{CC} < 5.5 V$ , $f_c = 400 kHz$		2	mA
$I_{CC0}$	Supply current (Write)	During $t_W$ , $2.5 V < V_{CC} < 5.5 V$		5 <sup>(1)</sup>	mA
$I_{CC1}$	Standby supply current	Device not selected <sup>(2)</sup> , $V_{IN} = V_{SS}$ or $V_{CC}$ , $2.5 V < V_{CC} < 5.5 V$		10	$\mu A$
$V_{IL}$	Input low voltage (SDA, SCL, $\overline{WC}$ )		-0.45	$0.3V_{CC}$	V
$V_{IH}$	Input high voltage (SCL, SDA)		$0.7V_{CC}$	6.5	V
	Input high voltage ( $\overline{WC}$ , E0, E1, E2)		$0.7V_{CC}$	$V_{CC}+0.6$	V
$V_{OL}$	Output low voltage	$I_{OL} = 2.1 mA$ , $V_{CC} = 2.5 V$ or $I_{OL} = 3 mA$ , $V_{CC} = 5.5 V$		0.4	V

1. Characterized value, not tested in production.
2. The device is not selected after power-up, after a Read command (after the Stop condition) or after the completion of the internal write cycle  $t_W$  ( $t_W$  is triggered by the correct decoding of a Write command).

Table 14. DC characteristics (M24xxx-R - device grade 6)

Symbol	Parameter	Test condition (in addition to those in Table 8) <sup>(1)</sup>	Min.	Max.	Unit
$I_{LI}$	Input leakage current (SCL, SDA, E2, E1, E0)	$V_{IN} = V_{SS}$ or $V_{CC}$ device in Standby mode		$\pm 2$	$\mu A$
$I_{LO}$	Output leakage current	SDA Hi-Z, external voltage applied on SDA: $V_{SS}$ or $V_{CC}$		$\pm 2$	$\mu A$
$I_{CC}$	Supply current (Read)	$V_{CC} = 1.8 V$ , $f_c = 400 kHz$		0.8	mA
$I_{CC0}$	Supply current (Write)	During $t_W$ , $1.8 V < V_{CC} < 2.5 V$		3 <sup>(2)</sup>	mA
$I_{CC1}$	Standby supply current	Device not selected <sup>(3)</sup> , $V_{IN} = V_{SS}$ or $V_{CC}$ , $V_{CC} = 1.8 V$		1	$\mu A$
$V_{IL}$	Input low voltage (SDA, SCL, $\overline{WC}$ )	$1.8 V \leq V_{CC} < 2.5 V$	-0.45	$0.25 V_{CC}$	V
		$2.5 V \leq V_{CC} < 5.5 V$	-0.45	$0.3 V_{CC}$	V
$V_{IH}$	Input high voltage (SCL, SDA)		$0.7V_{CC}$	6.5	V
	Input high voltage ( $\overline{WC}$ , E0, E1, E2)		$0.7V_{CC}$	$V_{CC}+0.6$	V
$V_{OL}$	Output low voltage	$I_{OL} = 1 mA$ , $V_{CC} = 1.8 V$		0.2	V

1. If the application uses the M24C32-R at  $2.5 V < V_{CC} < 5.5 V$  and  $-40^\circ C < T_A < +85^\circ C$ , please refer to [Table 12: DC characteristics \(M24xxx-W, device grade 6\)](#) instead of the above table.
2. Characterized value, not tested in production.
3. The device is not selected after power-up, after a Read command (after the Stop condition) or after the completion of the internal write cycle  $t_W$  ( $t_W$  is triggered by the correct decoding of a Write command).

Table 15. DC characteristics (M24xxx-F)

Symbol	Parameter	Test condition (in addition to those in <i>Table 9</i> )	Min.	Max.	Unit
$I_{LI}$	Input leakage current (SCL, SDA, E2, E1, E0)	$V_{IN} = V_{SS}$ or $V_{CC}$ device in Standby mode		$\pm 2$	$\mu A$
$I_{LO}$	Output leakage current	SDA Hi-Z, external voltage applied on SDA: $V_{SS}$ or $V_{CC}$		$\pm 2$	$\mu A$
$I_{CC}$	Supply current (Read)	$V_{CC} = 1.7 V$ , $f_c = 400 kHz$		0.8	mA
$I_{CC0}$	Supply current (Write)	During $t_W$ , $1.7 V < V_{CC} < 2.5 V$		3 <sup>(1)</sup>	mA
$I_{CC1}$	Standby supply current	Device not selected <sup>(2)</sup> , $V_{IN} = V_{SS}$ or $V_{CC}$ , $V_{CC} = 1.7 V$		1	$\mu A$
$V_{IL}$	Input low voltage (SDA, SCL, $\overline{WC}$ )	$1.8 V \leq V_{CC} < 2.5 V$	-0.45	$0.25 V_{CC}$	V
		$2.5 V \leq V_{CC} < 5.5 V$	-0.45	$0.3 V_{CC}$	V
$V_{IH}$	Input high voltage (SCL, SDA)		$0.7V_{CC}$	6.5	V
	Input high voltage ( $\overline{WC}$ , E0, E1, E2)		$0.7V_{CC}$	$V_{CC}+0.6$	V
$V_{OL}$	Output low voltage	$I_{OL} = 0.7 mA$ , $V_{CC} = 1.7 V$		0.2	V

1. Characterized value, not tested in production.
2. The device is not selected after power-up, after a Read command (after the Stop condition) or after the completion of the internal write cycle  $t_W$  ( $t_W$  is triggered by the correct decoding of a Write command).

Table 16. AC characteristics

Test conditions specified in <a href="#">Table 7</a> , <a href="#">Table 8</a> and <a href="#">Table 9</a>					
Symbol	Alt.	Parameter	Min.	Max.	Unit
$f_C$	$f_{SCL}$	Clock frequency		400	kHz
$t_{CHCL}$	$t_{HIGH}$	Clock pulse width high	600		ns
$t_{CLCH}$	$t_{LOW}$	Clock pulse width low	1300		ns
$t_{QL1QL2}^{(1)}$	$t_F$	SDA (out) fall time	20 <sup>(2)</sup>	120	ns
$t_{XH1XH2}$	$t_R$	Input signal rise time	(3)	(3)	ns
$t_{XL1XL2}$	$t_F$	Input signal fall time	(3)	(3)	ns
$t_{DXCX}$	$t_{SU:DAT}$	Data in set up time	100		ns
$t_{CLDX}$	$t_{HD:DAT}$	Data in hold time	0		ns
$t_{CLQX}$	$t_{DH}$	Data out hold time	200		ns
$t_{CLQV}^{(4)(5)}$	$t_{AA}$	Clock low to next data valid (access time)	200	900	ns
$t_{CHDL}$	$t_{SU:STA}$	Start condition setup time	600		ns
$t_{DLCL}$	$t_{HD:STA}$	Start condition hold time	600		ns
$t_{CHDH}$	$t_{SU:STO}$	Stop condition set up time	600		ns
$t_{DHDL}$	$t_{BUF}$	Time between Stop condition and next Start condition	1300		ns
$t_W$	$t_{WR}$	Write time		5	ms

1. Characterized only, not tested in production.
2. With  $C_L = 10$  pF.
3. There is no min. or max. values for the input signal rise and fall times. It is however recommended by the I<sup>2</sup>C specification that the input signal rise and fall times be more than 20 ns and less than 300 ns when  $f_C < 400$  kHz.
4. To avoid spurious Start and Stop conditions, a minimum delay is placed between SCL=1 and the falling or rising edge of SDA.
5.  $t_{CLQV}$  is the time (from the falling edge of SCL) required by the SDA bus line to reach either  $0.3V_{CC}$  or  $0.7V_{CC}$ , assuming that  $R_{bus} \times C_{bus}$  time constant is within the values specified in [Figure 4](#).

Figure 12. AC waveforms

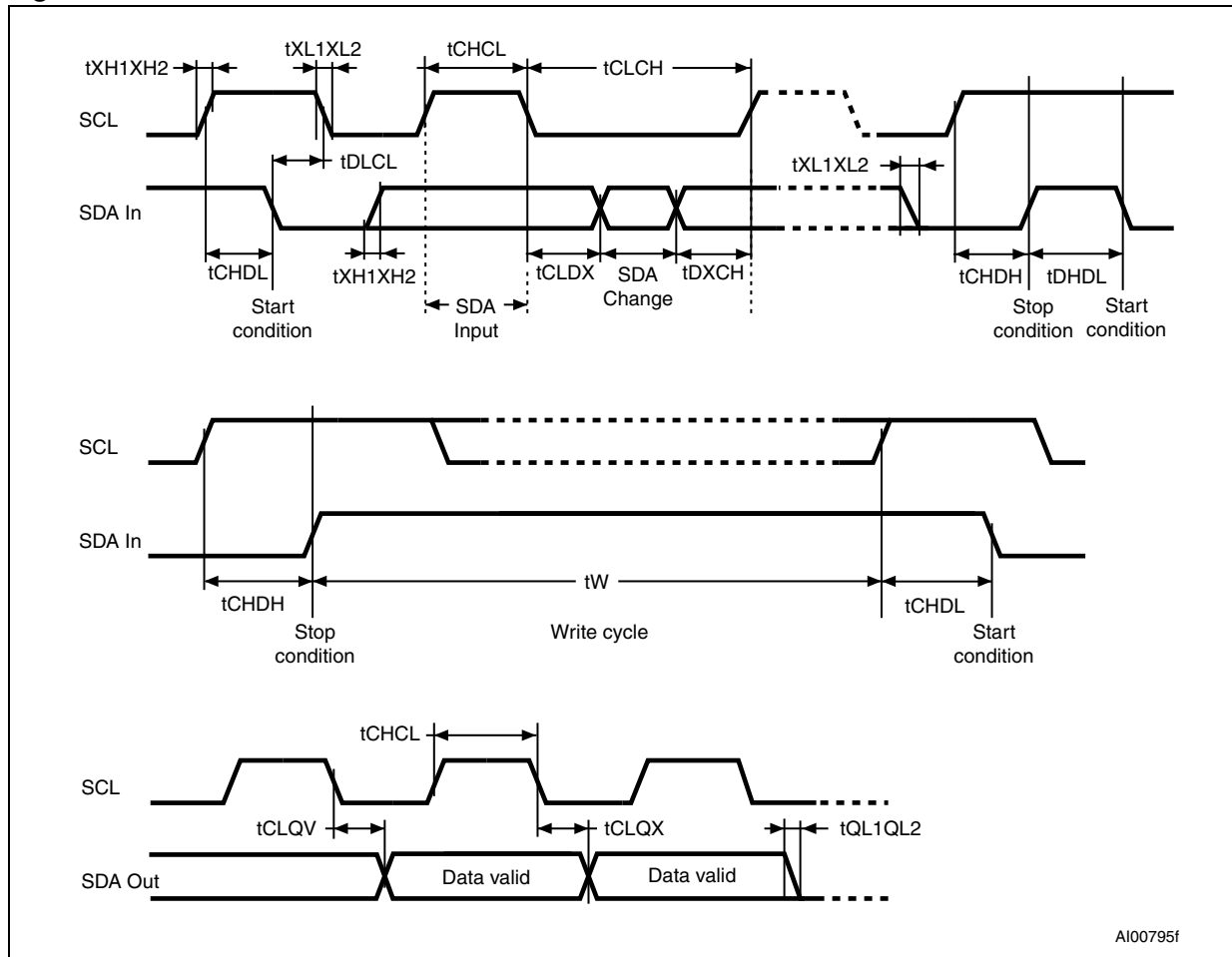

## 8 Package mechanical data

In order to meet environmental requirements, ST offers these devices in different grades of ECOPACK® packages, depending on their level of environmental compliance. ECOPACK® specifications, grade definitions and product status are available at: [www.st.com](http://www.st.com). ECOPACK® is an ST trademark.

**Figure 13. PDIP8 – 8 pin plastic DIP, 0.25 mm lead frame, package outline**

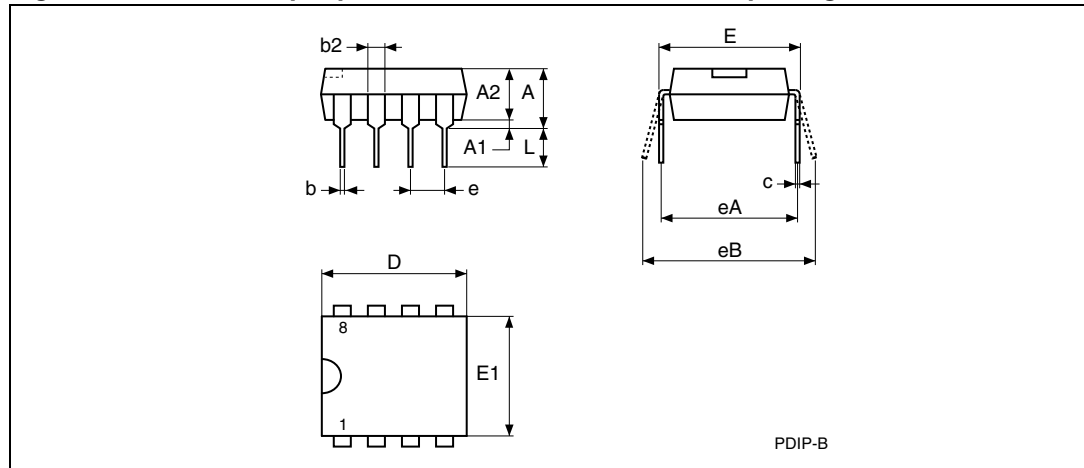

1. Drawing is not to scale.

**Table 17. PDIP8 – 8 pin plastic DIP, 0.25 mm lead frame, package mechanical data**

Symbol	millimeters			inches <sup>(1)</sup>		
	Typ.	Min.	Max.	Typ.	Min.	Max.
A			5.33			0.2098
A1		0.38			0.0150	
A2	3.30	2.92	4.95	0.1299	0.1150	0.1949
b	0.46	0.36	0.56	0.0181	0.0142	0.0220
b2	1.52	1.14	1.78	0.0598	0.0449	0.0701
c	0.25	0.20	0.36	0.0098	0.0079	0.0142
D	9.27	9.02	10.16	0.3650	0.3551	0.4000
E	7.87	7.62	8.26	0.3098	0.3000	0.3252
E1	6.35	6.10	7.11	0.2500	0.2402	0.2799
e	2.54	–	–	0.1000	–	–
eA	7.62	–	–	0.3000	–	–
eB			10.92			0.4299
L	3.30	2.92	3.81	0.1299	0.1150	0.1500

1. Values in inches are converted from mm and rounded to 4 decimal digits.

Figure 14. SO8 narrow – 8 lead plastic small outline, 150 mils body width, package outline

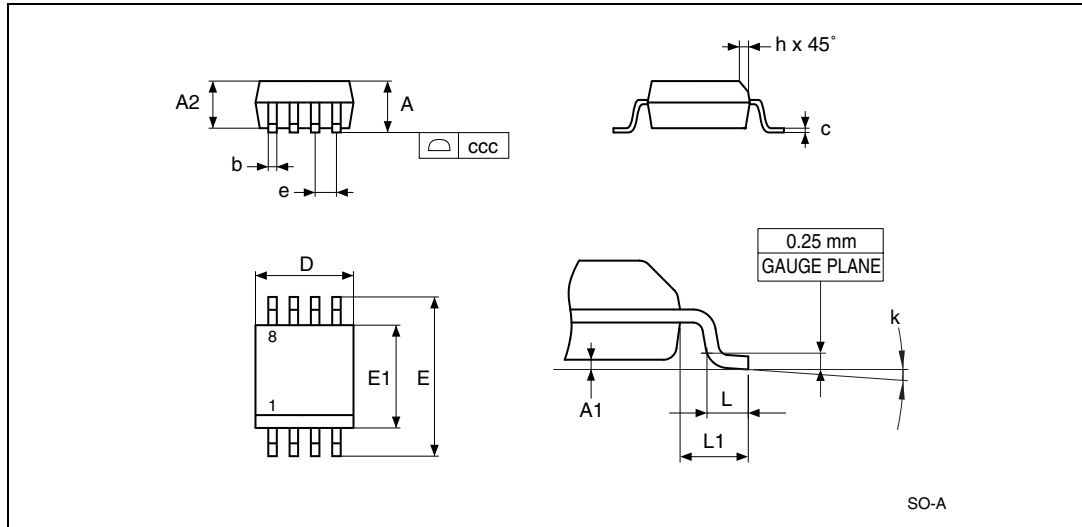

1. Drawing is not to scale.

Table 18. SO8 narrow – 8 lead plastic small outline, 150 mils body width, package mechanical data

Symbol	millimeters			inches <sup>(1)</sup>		
	Typ	Min	Max	Typ	Min	Max
A			1.75			0.0689
A1		0.10	0.25		0.0039	0.0098
A2		1.25			0.0492	
b		0.28	0.48		0.0110	0.0189
c		0.17	0.23		0.0067	0.0091
ccc			0.10			0.0039
D	4.90	4.80	5.00	0.1929	0.1890	0.1969
E	6.00	5.80	6.20	0.2362	0.2283	0.2441
E1	3.90	3.80	4.00	0.1535	0.1496	0.1575
e	1.27	–	–	0.0500	–	–
h		0.25	0.50			
k		0°	8°		0°	8°
L		0.40	1.27		0.0157	0.0500
L1	1.04			0.0410		

1. Values in inches are converted from mm and rounded to 4 decimal digits.

Figure 15. TSSOP8 – 8 lead thin shrink small outline, package outline

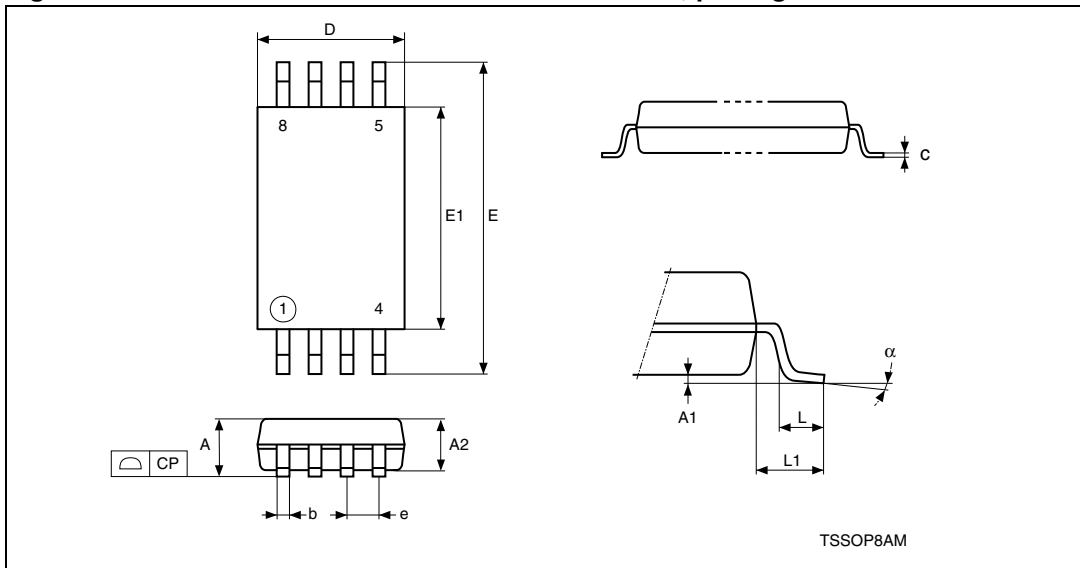

1. Drawing is not to scale.

Table 19. TSSOP8 – 8 lead thin shrink small outline, package mechanical data

Symbol	millimeters			inches <sup>(1)</sup>		
	Typ.	Min.	Max.	Typ.	Min.	Max.
A			1.200			0.0472
A1		0.050	0.150		0.0020	0.0059
A2	1.000	0.800	1.050	0.0394	0.0315	0.0413
b		0.190	0.300		0.0075	0.0118
c		0.090	0.200		0.0035	0.0079
CP			0.100			0.0039
D	3.000	2.900	3.100	0.1181	0.1142	0.1220
e	0.650	–	–	0.0256	–	–
E	6.400	6.200	6.600	0.2520	0.2441	0.2598
E1	4.400	4.300	4.500	0.1732	0.1693	0.1772
L	0.600	0.450	0.750	0.0236	0.0177	0.0295
L1	1.000			0.0394		
α		0°	8°		0°	8°

1. Values in inches are converted from mm and rounded to 4 decimal digits.

**Figure 16. UFDFPN8 (MLP8) – 8-lead ultra thin fine pitch dual flat package no lead  
2 × 3mm, package outline**

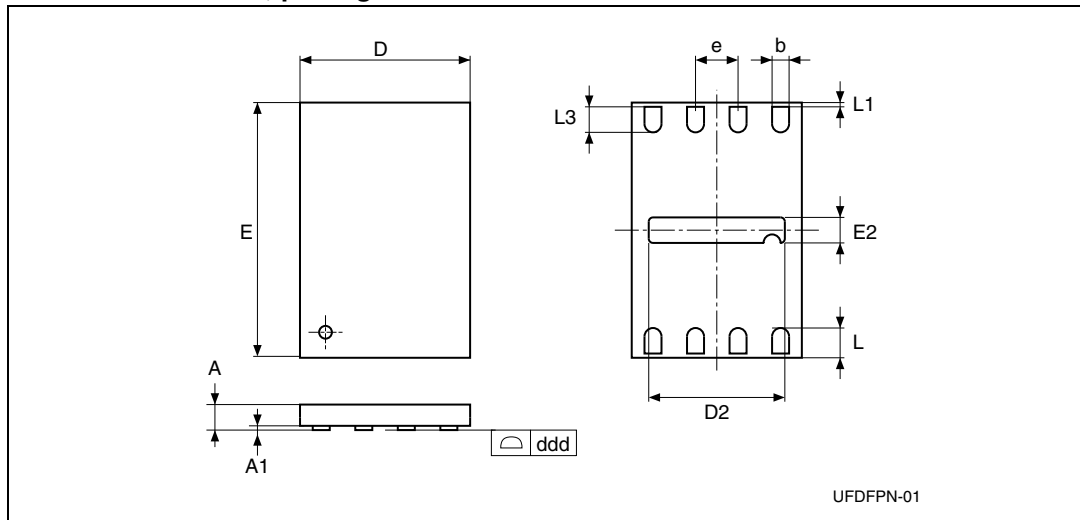

1. Drawing is not to scale.
2. The central pad (the E2 × D2 area in the above illustration) is internally pulled to V<sub>SS</sub>. It should not be connected to any other voltage or signal line on the PCB, for example during the soldering process.

**Table 20. UFDFPN8 (MLP8) – 8-lead ultra thin fine pitch dual flat package no lead  
2 × 3mm, package mechanical data**

Symbol	millimeters			inches <sup>(1)</sup>		
	Typ	Min	Max	Typ	Min	Max
A	0.55	0.50	0.60	0.0217	0.0197	0.0236
A1	0.02	0.00	0.05	0.0008	0	0.0020
b	0.25	0.20	0.30	0.0098	0.0079	0.0118
D	2.00	1.90	2.10	0.0787	0.0748	0.0827
D2	1.60	1.50	1.70	0.0630	0.0591	0.0669
ddd			0.08			0.0031
E	3.00	2.90	3.10	0.1181	0.1142	0.1220
E2	0.20	0.10	0.30	0.0079	0.0039	0.0118
e	0.50	–	–	0.0197	–	–
L	0.45	0.40	0.50	0.0177	0.0157	0.0197
L1			0.15			0.0059
L3		0.30			0.0118	

1. Values in inches are converted from mm and rounded to 4 decimal digits.

## 9 Part numbering

**Table 21. Ordering information scheme**

Example:	M24C32-	W	MN	6	T	P	/P
<b>Device type</b> M24 = I <sup>2</sup> C serial access EEPROM							
<b>Device function</b> C32- = 32 Kbit (4096 x 8)							
<b>Operating voltage</b> W = V <sub>CC</sub> = 2.5 V to 5.5 V R = V <sub>CC</sub> = 1.8 V to 5.5 V F = V <sub>CC</sub> = 1.7 V to 5.5 V							
<b>Package</b> BN = PDIP8 <sup>(1)</sup> MN = SO8 (150 mil width) <sup>(2)</sup> DW = TSSOP8 (169 mil width) <sup>(2)</sup> MB = UFDFPN8 (MLP8) <sup>(2)</sup>							
<b>Device grade</b> 6 = Industrial: device tested with standard test flow over -40 to 85 °C 3 = Automotive: device tested with high reliability certified flow <sup>(3)</sup> over -40 to 125°C. 5 = Consumer: device tested with standard test flow over -20 to 85°C							
<b>Option</b> blank = standard packing T = Tape and reel packing							
<b>Plating technology</b> P or G = ECOPACK <sup>®</sup> (RoHS compliant)							
<b>Process<sup>(4)</sup></b> P = F6DP26% Chartered A = F8L Rousset (only for the WLCSP package)							

1. ECOPACK1<sup>®</sup> (RoHS-compliant).
2. ECOPACK2<sup>®</sup> (RoHS-compliant and Halogen-free).
3. ST strongly recommends the use of the Automotive Grade devices for use in an automotive environment. The high reliability certified flow (HRCF) is described in the quality note QNEE9801. Please ask your nearest ST sales office for a copy.
4. Used only for device grade 3 and WLCSP packages.

For a list of available options (speed, package, etc.) or for further information on any aspect of this device, please contact your nearest ST sales office.

**Table 22. Available M24C32 products (package, voltage range, temperature grade)**

<b>Package</b>	<b>M24C32-F 1.7 V to 5.5 V</b>	<b>M24C32-R 1.8 V to 5.5 V</b>	<b>M24C32-W 2.5 V to 5.5 V</b>
DIP8 (BN)	-	-	Grade6
SO8N (MN)	-	Grade 6	Grade 3 Grade 6
TSSOP8 (DW)	Grade 5	Grade 6	Grade 6
MLP8 (MB)	Grade 5	Grade 6	-

## 10 Revision history

**Table 23. Document revision history**

Date	Revision	Changes
22-Dec-1999	2.3	TSSOP8 package in place of TSSOP14 (pp 1, 2, OrderingInfo, PackageMechData).
28-Jun-2000	2.4	TSSOP8 package data corrected
31-Oct-2000	2.5	References to Temperature Range 3 removed from Ordering Information Voltage range -S added, and range -R removed from text and tables throughout.
20-Apr-2001	2.6	Lead Soldering Temperature in the Absolute Maximum Ratings table amended Write Cycle Polling Flow Chart using ACK illustration updated References to PSDIP changed to PDIP and Package Mechanical data updated
16-Jan-2002	2.7	Test condition for $I_{L1}$ made more precise, and value of $I_{L1}$ for E2-E0 and WC added -R voltage range added
02-Aug-2002	2.8	Document reformatted using new template. TSSOP8 (3x3mm <sup>2</sup> body size) package (MSOP8) added. 5ms write time offered for 5V and 2.5V devices
04-Feb-2003	2.9	SO8W package removed. -S voltage range removed
27-May-2003	2.10	TSSOP8 (3x3mm <sup>2</sup> body size) package (MSOP8) removed
22-Oct-2003	3.0	Table of contents, and Pb-free options added. Minor wording changes in Summary Description, Power-On Reset, Memory Addressing, Write Operations, Read Operations. $V_{IL}(\min)$ improved to -0.45V.
01-Jun-2004	4.0	Absolute Maximum Ratings for $V_{IO}(\min)$ and $V_{CC}(\min)$ improved. Soldering temperature information clarified for RoHS compliant devices. Device Grade clarified
04-Nov-2004	5.0	Product List summary table added. Device Grade 3 added. 4.5-5.5V range is Not for New Design. Some minor wording changes. AEC-Q100-002 compliance. $t_{NS}(\max)$ changed. $V_{IL}(\min)$ is the same on all input pins of the device. $Z_{WCL}$ changed.
05-Jan-2005	6.0	UFDFPN8 package added. Small text changes.

Table 23. Document revision history (continued)

Date	Revision	Changes
29-Jun-2006	7	<p>Document converted to new ST template.</p> <p>M24C32 and M24C64 products (4.5 to 5.5V supply voltage) removed. M24C64 and M24C32 products (1.7 to 5.5V supply voltage) added.</p> <p><i>Section 2.3: Chip Enable (E0, E1, E2)</i> and <i>Section 2.4: Write Control (WC)</i> modified, <i>Section 2.6: Supply voltage (V<sub>CC</sub>)</i> added and replaces <i>Power On Reset: VCC Lock-Out Write Protect</i> section.</p> <p>T<sub>A</sub> added, <i>Note 1</i> updated and T<sub>LEAD</sub> specified for PDIP packages in <i>Table 6: Absolute maximum ratings</i>.</p> <p>I<sub>CC0</sub> added, I<sub>CC</sub> voltage conditions changed and I<sub>CC1</sub> specified over the whole voltage range in <i>Table 12: DC characteristics (M24xxx-W, device grade 6)</i>.</p> <p>I<sub>CC0</sub> added, I<sub>CC</sub> frequency conditions changed and I<sub>CC1</sub> specified over the whole voltage range in <i>Table 14: DC characteristics (M24xxx-R - device grade 6)</i>.</p> <p>t<sub>W</sub> modified in <i>Table 16: AC characteristics</i>.</p> <p>SO8N package specifications updated (see <i>Figure 14</i> and <i>Table 18</i>).</p> <p>Device grade 5 added, B and P Process letters added to <i>Table 21: Ordering information scheme</i>. Small text changes.</p>
03-Jul-2006	8	<p>I<sub>CC1</sub> modified in <i>Table 12: DC characteristics (M24xxx-W, device grade 6)</i>.</p> <p><i>Note 1</i> added to <i>Table 15: DC characteristics (M24xxx-F)</i> and table title modified.</p>
17-Oct-2006	9	<p>UFDFPN8 package specifications updated (see <i>Table 20</i>). M24128-BW- and M24128-BR part numbers added.</p> <p>Generic part number corrected in <i>Features on page 1</i>.</p> <p>I<sub>CC0</sub> corrected in <i>Table 13</i> and <i>Table 12</i>.</p> <p>Packages are ECOPACK® compliant.</p>
27-Apr-2007	10	<p>Available packages and temperature ranges by product specified in <i>Table 22</i>, <i>Table 24</i> and <i>Table 25</i>.</p> <p>Notes modified below <i>Table 11: Input parameters</i>.</p> <p>V<sub>IH</sub> max modified in DC characteristics tables (see <i>Table 12</i>, <i>Table 13</i>, <i>Table 14</i> and <i>Table 15</i>).</p> <p>C process code added to <i>Table 21: Ordering information scheme</i>.</p> <p>For M24xxx-R (1.8 V to 5.5 V range) products assembled from July 2007 on, t<sub>W</sub> will be 5 ms (see <i>Table 16: AC characteristics</i>).</p>
27-Nov-2007	11	<p>Small text changes. <i>Section 2.5: V<sub>SS</sub> ground</i> and <i>Section 4.9: ECC (error correction code) and write cycling</i> added.</p> <p>V<sub>IL</sub> and V<sub>IH</sub> modified in <i>Table 14: DC characteristics (M24xxx-R - device grade 6)</i>.</p> <p>JEDEC standard reference updated below <i>Table 6: Absolute maximum ratings</i>.</p> <p>Package mechanical data inch values calculated from mm and rounded to 4 decimal digits (see <i>Section 8: Package mechanical data</i>).</p>

Table 23. Document revision history (continued)

Date	Revision	Changes
18-Dec-2007	12	<p>Added <a href="#">Section 2.6.2: Power-up conditions</a>, updated <a href="#">Section 2.6.3: Device reset</a>, and <a href="#">Section 2.6.4: Power-down conditions</a> in <a href="#">Section 2.6: Supply voltage (<math>V_{CC}</math>)</a>.</p> <p>Updated <a href="#">Figure 4: Maximum <math>R_p</math> value versus bus parasitic capacitance (<math>C</math>) for an I<sup>2</sup>C bus</a>.</p> <p>Replace M24128 and M24C64 by M24128-BFMB6 and M24C64-FMB6, respectively, in <a href="#">Section 4.9: ECC (error correction code) and write cycling</a>.</p> <p>Added temperature grade 6 in <a href="#">Table 9: Operating conditions (M24xxx-F)</a>.</p> <p>Updated test conditions for <math>I_{LO}</math> and <math>V_{LO}</math> in <a href="#">Table 12: DC characteristics (M24xxx-W, device grade 6)</a>, <a href="#">Table 13: DC characteristics (M24xxx-W, device grade 3)</a>, and <a href="#">Table 14: DC characteristics (M24xxx-R - device grade 6)</a>.</p> <p>Test condition updated for <math>I_{LO}</math>, and <math>V_{IH}</math> and <math>V_{IL}</math> differentiate for <math>1.8\text{ V} \leq V_{CC} &lt; 2.5\text{ V}</math> and <math>2.5\text{ V} \leq V_{CC} &lt; 5.5\text{ V}</math> in <a href="#">Table 15: DC characteristics (M24xxx-F)</a>.</p> <p>Updated <a href="#">Table 16: AC characteristics</a>, and <a href="#">Table 17: AC characteristics (M24xxx-F)</a>.</p> <p>Updated <a href="#">Figure 12: AC waveforms</a>.</p> <p>Added M24128-BF in <a href="#">Table 25: Available M24C32 products (package, voltage range, temperature grade)</a>.</p> <p>Process B removed from <a href="#">Table 21: Ordering information scheme</a>.</p>
30-May-2008	13	<p>Small text changes.</p> <p>C <a href="#">Process</a> option and Blank <a href="#">Plating technology</a> option removed from <a href="#">Table 21: Ordering information scheme</a>.</p>
15-Jul-2008	14	<p>WLCSP package added (see <a href="#">Figure 3: WLCSP connections (top view, marking side, with balls on the underside)</a> and <a href="#">Section 8: Package mechanical data</a>). <a href="#">Section 4.9: ECC (error correction code) and write cycling</a> updated.</p>
16-Sep-2008	15	<p><math>I_{OL}</math> added to <a href="#">Table 6: Absolute maximum ratings</a>.</p> <p><a href="#">Table 24: Available M24C32 products (package, voltage range, temperature grade)</a> and <a href="#">Table 25: Available M24C32 products (package, voltage range, temperature grade)</a> updated.</p>

Table 23. Document revision history (continued)

Date	Revision	Changes
05-Jan-2009	16	I2C modes supported specified in <a href="#">Features on page 1</a> . Note removed from <a href="#">Table 15: DC characteristics (M24xxx-F)</a> . Small text changes.
07-Dec-2009	17	64 and 128 Kbit densities removed. ECOPACK status of packages specified <a href="#">on page 1</a> and in <a href="#">Table 21: Ordering information scheme</a> . <a href="#">Section 2.6.2: Power-up conditions</a> updated. <a href="#">Figure 4: Maximum <math>R_P</math> value versus bus parasitic capacitance (C) for an I<sup>2</sup>C bus</a> updated. ECC section removed. $t_{NS}$ modified in <a href="#">Table 11: Input parameters</a> . $I_{CC1}$ and $V_{IH}$ updated in <a href="#">Table 12: DC characteristics (M24xxx-W, device grade 6)</a> , <a href="#">Table 13: DC characteristics (M24xxx-W, device grade 3)</a> , <a href="#">Table 14: DC characteristics (M24xxx-R - device grade 6)</a> and <a href="#">Table 15: DC characteristics (M24xxx-F)</a> . Note added to <a href="#">Table 14: DC characteristics (M24xxx-R - device grade 6)</a> . <a href="#">Table 16: AC characteristics</a> modified. <a href="#">Figure 12: AC waveforms</a> modified. Note added below <a href="#">Figure 16: UDFPN8 (MLP8) – 8-lead ultra thin fine pitch dual flat package no lead 2 × 3mm, package outline</a> . Small text changes.

**Please Read Carefully:**

Information in this document is provided solely in connection with ST products. STMicroelectronics NV and its subsidiaries ("ST") reserve the right to make changes, corrections, modifications or improvements, to this document, and the products and services described herein at any time, without notice.

All ST products are sold pursuant to ST's terms and conditions of sale.

Purchasers are solely responsible for the choice, selection and use of the ST products and services described herein, and ST assumes no liability whatsoever relating to the choice, selection or use of the ST products and services described herein.

No license, express or implied, by estoppel or otherwise, to any intellectual property rights is granted under this document. If any part of this document refers to any third party products or services it shall not be deemed a license grant by ST for the use of such third party products or services, or any intellectual property contained therein or considered as a warranty covering the use in any manner whatsoever of such third party products or services or any intellectual property contained therein.

**UNLESS OTHERWISE SET FORTH IN ST'S TERMS AND CONDITIONS OF SALE ST DISCLAIMS ANY EXPRESS OR IMPLIED WARRANTY WITH RESPECT TO THE USE AND/OR SALE OF ST PRODUCTS INCLUDING WITHOUT LIMITATION IMPLIED WARRANTIES OF MERCHANTABILITY, FITNESS FOR A PARTICULAR PURPOSE (AND THEIR EQUIVALENTS UNDER THE LAWS OF ANY JURISDICTION), OR INFRINGEMENT OF ANY PATENT, COPYRIGHT OR OTHER INTELLECTUAL PROPERTY RIGHT.**

**UNLESS EXPRESSLY APPROVED IN WRITING BY AN AUTHORIZED ST REPRESENTATIVE, ST PRODUCTS ARE NOT RECOMMENDED, AUTHORIZED OR WARRANTED FOR USE IN MILITARY, AIR CRAFT, SPACE, LIFE SAVING, OR LIFE SUSTAINING APPLICATIONS, NOR IN PRODUCTS OR SYSTEMS WHERE FAILURE OR MALFUNCTION MAY RESULT IN PERSONAL INJURY, DEATH, OR SEVERE PROPERTY OR ENVIRONMENTAL DAMAGE. ST PRODUCTS WHICH ARE NOT SPECIFIED AS "AUTOMOTIVE GRADE" MAY ONLY BE USED IN AUTOMOTIVE APPLICATIONS AT USER'S OWN RISK.**

Resale of ST products with provisions different from the statements and/or technical features set forth in this document shall immediately void any warranty granted by ST for the ST product or service described herein and shall not create or extend in any manner whatsoever, any liability of ST.

ST and the ST logo are trademarks or registered trademarks of ST in various countries.

Information in this document supersedes and replaces all information previously supplied.

The ST logo is a registered trademark of STMicroelectronics. All other names are the property of their respective owners.

© 2009 STMicroelectronics - All rights reserved

STMicroelectronics group of companies

Australia - Belgium - Brazil - Canada - China - Czech Republic - Finland - France - Germany - Hong Kong - India - Israel - Italy - Japan - Malaysia - Malta - Morocco - Philippines - Singapore - Spain - Sweden - Switzerland - United Kingdom - United States of America

[www.st.com](http://www.st.com)