

Three-position device

the safest solution during trouble shooting, programming and testing

Why three-positions?

An operator who is under pressure must be able to give a stop signal, whether in panic he/she pushes harder on the button or just lets go of it.

Three-position devices, hold-in and acceptance devices can be used for trouble shooting, programming and test running in situations where no other protection is available or feasible.

If the operator has to enter a risk area to trouble shoot or run a test, it is extremely important that he/she is able to stop the machinery without having to rely on someone else to stand by a stop button that is further away. In addition, no-one else should be able to start the machinery from the outside after it has been stopped by use of the three-position device.

Hold to run device or Acceptance device, what is the difference?

Hold to run device: The start signal is given when the button is pressed. The stop signal is given when the button is released or pushed fully in.

Acceptance device: The start signal for separate starting is given when the button is pressed. The stop signal is given when the button is released or pushed fully in. "Separate start" means, for example, that a program start signal is sent to the robot via a separate button in the acceptance device.

The three-position device is designed to be ergonomic

The device is ergonomic, both in respect of its shape, fitting to the hand, and the way the buttons are operated. It is easy to operate the three-position device using just the fingers, and the middle position provides a secure resting position. The device has LED indications that show the operational status, i.e. stop or ready signal. The two additional buttons can be used, for example, for start/stop, up/down or forward/back. Internally the device is duplicated. The three-position function itself is built up of two completely independent three-position buttons which are felt by the user to be one button.

Approvals:



Use:

- Troubleshooting
- Test running
- Programming

Advantages:

- Ergonomic
- LED information
- Adaptable



Three-position devices in different versions



Highest safety level

whether the button is pushed or released

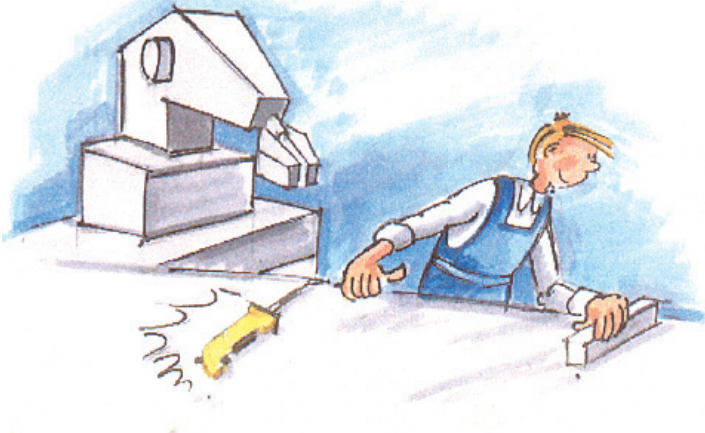

When the three-position button is released you will obtain a dual stop. It is essential that the machine stops when you put aside the three-position device, for example during adjustment.



When the three position button is pushed all the way in you will obtain a dual stop. It is essential that the machine stops in an emergency situation.



How does a a three-position device work?

Safety level

A safe Enabling or Hold to Run device should function as follows:

1. The Stop signal in released (top) and bottom position shall have the same safety level.
2. Provide a 'Start' or 'Ready' signal in a distinct middle position.
3. After a 'Stop' in the bottom position, a 'Start' signal or 'Ready' signal is not permitted until the three position push-buttons have been totally released and again pressed to the middle position.
This function is achieved mechanically within the three position push-buttons in the device.
4. A Short or Open circuit in the connection cables shall not lead to a dangerous function e.g. 'Start' or 'Ready' signal.

In order to meet the above conditions, the three-position switch must be connected to a suitable safety relay with a two channel function, e.g. RT6, RT9 or JSBT4, which can monitor that both three-position buttons are working and that there is no short or open circuit in the connection cable or the switch.

Released position

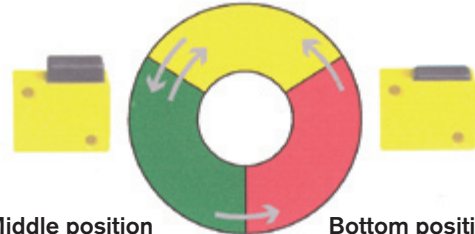

Middle position

Bottom position

Regulations and standards

The JSHD4 is designed and approved in accordance with appropriate directives and standards. Examples of the applicable regulations and standards are: 98/37/EC, EN ISO 12100-1/-2, EN 954-1/EN ISO 13849-1.



Three-position device fitted to a machine control unit.



Panel assembly of JSHD4H2 on a programming unit for robots.

Three-position device

versions and possibilities

The JSHD4 three-position device is readily available in many standard versions. It is also possible to customize the three-position device for specific applications.

The three-position device can be customized by the selection of the following parts:

- **Front button** - for programme start, low speed, etc.
- **Top button** - for programme stop, grip devices, etc.
- **Bottom plate** - wide bottom plate for fixing interlocking devices and Eden (non-contact sensor) or narrow bottom plate for more flexible handling.
- **Cable**, straight or spiral cable with connectors or assembled on the device
- **LEDs**, alternative connections
- **Designed to work with a PLC** or a safety relay

Top button

Front button



Bottom plates

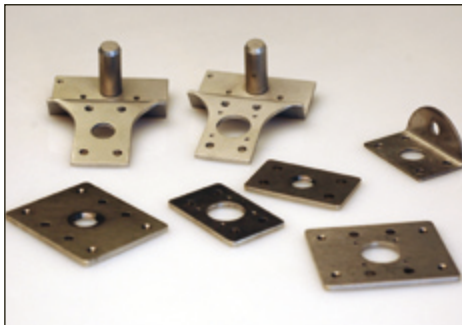

Connections



Cables



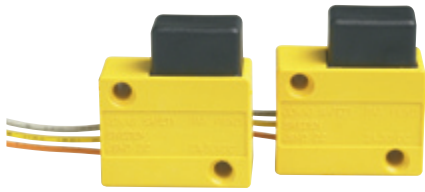

Three-position push button JSHD2C

The button is the main component in a safe three-position solution. To achieve the highest safety level two buttons are used in a two-channel system.



Panel assembly JSHD4H2

A panel assembly suitable for building into programming units or similar control boxes. Provides simultaneous activation of both of the three-position buttons.



External assembly JSHD4H2A

The external assembly is similar to the panel assembly unit, although it is a 'handle' design making it suitable for assembly on the outside of a control box.

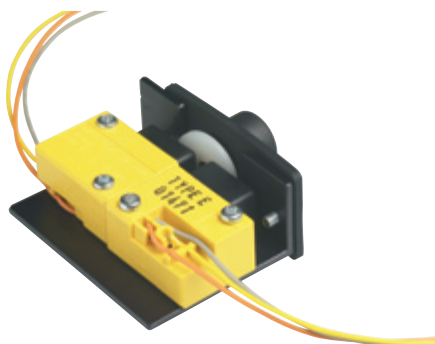

Upgrading kit JSHD4S2

This kit is used to upgrade 'older robot' control systems and will, together with a suitable safety relay, achieve a safe two-channel three-position function.

Dimensions

JSHD4

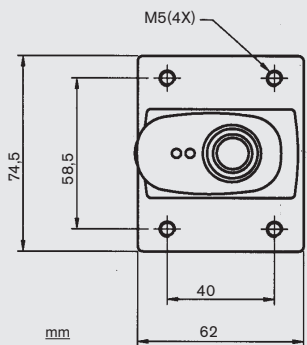
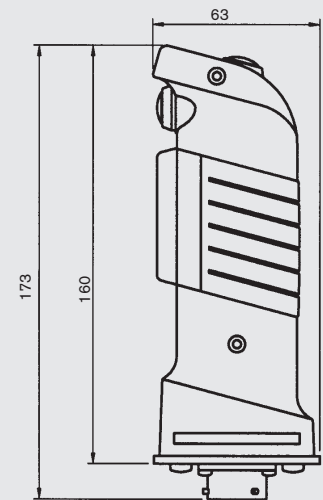

JSHD2C

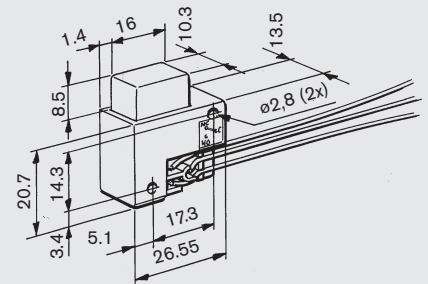

JSHD4H2

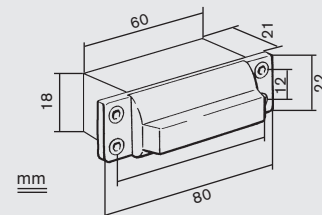

JSHD4H2A

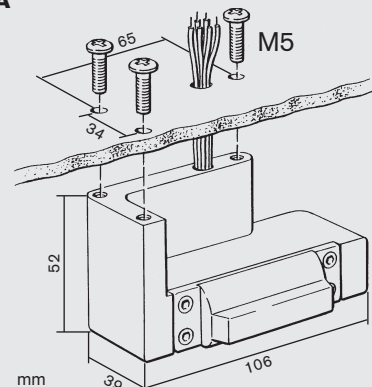

Technical data - JSHD4	
Manufacturer	JOKAB SAFETY AB, Sweden
Electrical contact ratings	30 VDC, max 0.5 A (min. 10 mA, 10V) 50 VAC/DC max 0.2 A
Three-position button: Extra button:	
Protection class	IP 65
Operating temperature	-10 to +50° C
Function indication	
Three-position buttons ready signal:	'Yes', green LED 'No', red LED
Material	Polyamide 6.6
Insulation resistance	min 20 M Ohm
Operation force	approx. 15 N
Mechanical life	1 000 000 cycles to middle position

Pin	Color STD	Color JSHK-S
A	White	White
B	Brown	Brown
C	Green	Green
D	Yellow	Yellow
E	Grey	-
F	Pink	Grey
G	Blue	Pink
H	Red	Blue
I	Black	Red
J	Purple	-
K	-	-
L	-	-

STD: JSHK, JSHK-E, JSHK-T

Ordering data/Article numbers

Article numbers Description

Standard versions

20-002-00	JSHD4 Three-position device with extra buttons (top/front)
20-002-01	JSHD4D Three-position device with extra button (front)
20-002-03	JSHD4E Three-position device with extra button (top)
20-002-04	JSHD4F Three-position device without extra buttons
20-002-37	JSHD4XN Three-position device for harsh environments
20-002-78	JSHD4MU Three-position device for Eden
20-002-79	JSHD4FA Three-position device for PLC with spiral cable
20-002-97	JSHD4PD Three-position device with potentiometer
20-002-02	JSHD4H2A Three-position device for external panel assembly
20-002-07	JSHD4S2 Three-position device, ABB upgrading kit
20-002-31	JSHD4H2 Three-position device for internal panel assembly
20-001-10	JSHD2C type E Three-position button
20-001-13	JSHD2C type K Three-position button

Accessories

20-003-03	JSHK0 12 pole connector
20-003-00	JSHK5 5 Metre cable and connector
20-003-01	JSHK10 10 Metre cable and connector
20-003-02	JSHK15 15 Metre cable and connector
20-003-04	JSHK20 20 Metre cable and connector
20-003-05	JSHK25 25 Metre cable and connector
20-003-10	JSHK5-E 5 metre extension cable
20-003-30	JSHK-T1 Cable drum
20-003-20	JSHK16S 1.6 Metre spiral cable and connector
20-003-21	JSHK20S 2.0 Metre spiral cable and connector
20-003-22	JSHK28S 2.8 Metre spiral cable and connector
20-003-23	JSHK32S 3.2 Metre spiral cable and connector
20-003-24	JSHK40S 4.0 Metre spiral cable and connector
20-003-25	JSHK60S 6.0 Metre spiral cable and connector
20-003-26	JSHK80S 8.0 Metre spiral cable and connector
40-005-03	JSM5A Wall bracket for 2 interlock switches and three-position device
20-205-28	JSM54A Wall bracket for Adam
40-005-05	JSM55 Wall bracket for three-position device



JSHK0 12 pole connector for JSHD4.



Spiral cable, available in different lengths.



Cable, available in different lengths.



Cable drum



JSM5A Wall bracket for interlock switches and three-position device.



JSM52A Wall bracket for three-position device.

NOTE! Contact us for other variants.

Connection example - Three-position device JSHD4 to Pluto

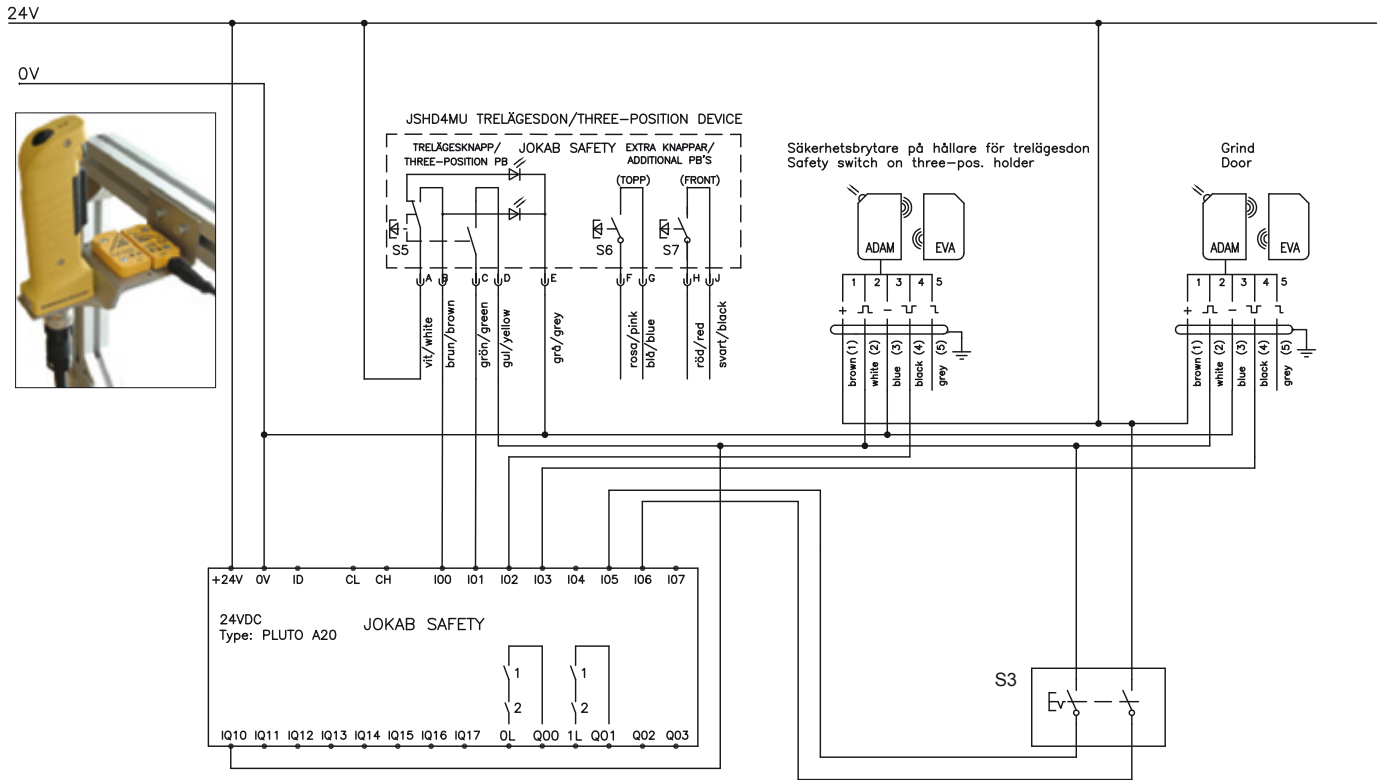

Time-limited entrance/exit

After lifting the three-position device out of its holder JSM54A, the interlocked gate can be passed for entrance into the risk area within x sec. The time limit is set in the Pluto program.

Connection examples - Three-position device JSHD4 with various safety modules

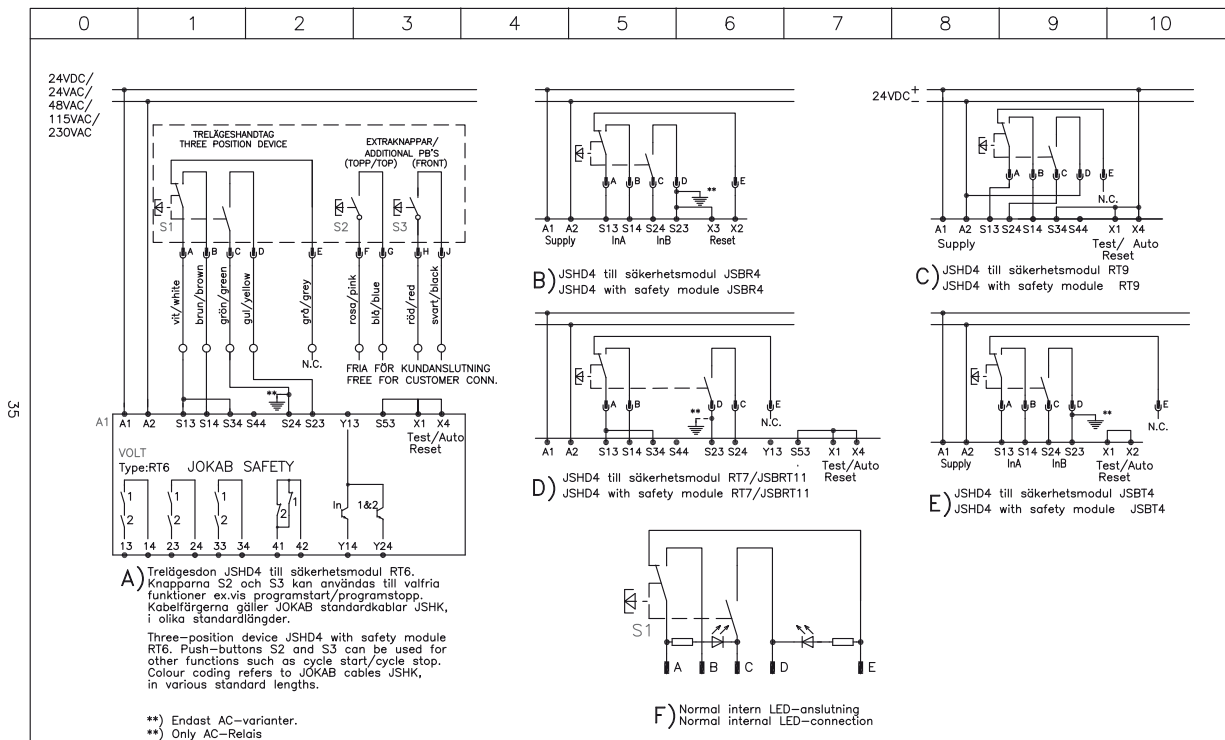

A) Trelägesdon JSHD4 till säkerhetsmodul RT6. Knapparna S2 och S3 kan användas till valfria funktioner ex.vis programstart/programstopp. Kabelfärgerna gäller JOKAB standardkablar JSHK, i olika standardlängder.

Three-position device JSHD4 with safety module RT6. Push-buttons S2 and S3 can be used for other functions such as cycle start/cycle stop. Colour coding refers to JOKAB cables JSHK, in various standard lengths.

** Endast AC-varianter.
** Only AC-Relais

Anmärkning Remark
TRELÄGESDON JSHD4 TILL OLIKA SÄKERHETSRELÄER
THREE-POSITION DEVICE JSHD4 WITH VARIOUS SAFETY MODULES

JOKAB SAFETY

Konstr Design	Godk Appr	Datum Date	Blad Sheet
JS		050105	1
Ritad Drawn	Sidor Pages	Ritnr nr	Forts Cont
MB	1	-	-

It is the user's responsibility to ensure that all control devices are correctly installed, cared for and operated to meet all applicable European, national and local codes/regulations. Specifications subject to change without notice.