

Resistance/potipotension transducer - MINI MCR-2-POT-UI - 2902016

Please be informed that the data shown in this PDF Document is generated from our Online Catalog. Please find the complete data in the user's documentation. Our General Terms of Use for Downloads are valid (<http://phoenixcontact.com/download>)



Configurable potipotension transducer with plug-in connection technology for connecting potentiometers from 0 Ω ... 100 Ω to 0 k Ω ... 100 k Ω . Configurable via DIP switch or software. Screw connection technology, standard configuration

Figure shows MINI MCR-2-POT-UI-PT version

Product description

Configurable, 3-way isolated potentiometer measuring transducer with plug-in connection technology. The measured values are converted into a linear and freely configurable current or voltage signal. You can optionally configure the device using DIP switches or with enhanced functionality via the S port using the standard ANALOG-CONF software via FDT/DTM or without further accessories using the MINI Analog Pro Smartphone app. If it is not possible to utilize the full potentiometer range, you can set the upper and lower potentiometer values in the software. The measuring transducer supports fault monitoring and NFC communication.



Key commercial data

Packing unit	1 pc
Weight per Piece (excluding packing)	20.0 GRM
Custom tariff number	85437090
Country of origin	Germany

Technical data

Note

Utilization restriction	EMC: class A product, see manufacturer's declaration in the download area
-------------------------	---

Dimensions

Width	6.2 mm
Height	110.5 mm
Depth	120.5 mm

Ambient conditions

Resistance/potipotension transducer - MINI MCR-2-POT-UI - 2902016

Technical data

Ambient conditions

Ambient temperature (operation)	-40 °C ... 70 °C
Ambient temperature (storage/transport)	-40 °C ... 85 °C

Input data

Potentiometer	100 Ω ... 100 kΩ
---------------	------------------

Output data

Voltage output signal	1 V ... 5 V (via DIP switch)
	10 V ... 0 V (via DIP switch)
	0 V ... 5 V (via DIP switch)
	0 V ... 10 V (via DIP switch)
	0 V ... 10.5 V (Can be set via software)
Current output signal	0 mA ... 20 mA (via DIP switch)
	4 mA ... 20 mA (via DIP switch)
	20 mA ... 0 mA (via DIP switch)
	20 mA ... 4 mA (via DIP switch)
	0 mA ... 21 mA (Can be set via software)
Max. voltage output signal	approx. 12.3 V
Max. current output signal	24.6 mA
Load/output load voltage output	≥ 10 kΩ
Load/output load current output	≤ 600 Ω (at 20 mA)

Power supply

Supply voltage	24 V DC
	9.6 V DC ... 30 V DC (The DIN rail bus connector (ME 6,2 TBUS-2 1,5/5-ST-3,81 GN, Order No. 2869728) can be used to bridge the supply voltage. It can be snapped onto a 35 mm DIN rail according to EN 60715))
Current consumption	33 mA (at 24 V DC)
	68 mA (at 12 V DC)

Connection data

Single conductor/terminal point, solid, with ferrule, min.	0.2 mm ²
Single conductor/terminal point, solid, with ferrule, max.	1.5 mm ²
Single conductor/terminal point, solid, without ferrule, min.	0.2 mm ²
Single conductor/terminal point, solid, without ferrule, max.	2.5 mm ²
Conductor cross section stranded min.	0.2 mm ²
Conductor cross section stranded max.	1.5 mm ²
Min. AWG conductor cross section, stranded	24
Max. AWG conductor cross section, stranded	12
Stripping length	10 mm

Resistance/potiposition transducer - MINI MCR-2-POT-UI - 2902016

Technical data

Connection data

Screw thread	M3
Connection method	Screw connection

General

Maximum transmission error	< 0.1 % (R < 240 Ω = < 0,2 %)
Maximum temperature coefficient	0.01 %/K
Step response (10-90%)	< 60 ms
Ambient temperature (operation)	-40 °C ... 70 °C
Ambient temperature (storage/transport)	-40 °C ... 85 °C
Housing material	PBT
Conformance	CE-compliant
ATEX	# II 3 G Ex nA IIC T4 Gc X
UL, USA / Canada	UL 508 Listed
GL	GL applied for

EMC data

Designation	Electromagnetic RF field
Standards/regulations	EN 61000-4-3
Typical deviation from the measuring range final value	0.2 %
Designation	Fast transients (burst)
Standards/regulations	EN 61000-4-4
Typical deviation from the measuring range final value	0.4 %
Designation	Conducted interferences
Standards/regulations	EN 61000-4-6
Typical deviation from the measuring range final value	0.2 %

Classifications

eCl@ss

eCl@ss 4.0	27210120
eCl@ss 4.1	27210120
eCl@ss 5.0	27210120
eCl@ss 5.1	27210120
eCl@ss 6.0	27210120
eCl@ss 7.0	27210120
eCl@ss 8.0	27210120

Resistance/potiposition transducer - MINI MCR-2-POT-UI - 2902016

Classifications

ETIM

ETIM 3.0	EC001485
ETIM 4.0	EC001446
ETIM 5.0	EC002653

UNSPSC

UNSPSC 6.01	30211506
UNSPSC 7.0901	39121008
UNSPSC 11	39121008
UNSPSC 12.01	39121008
UNSPSC 13.2	39121008

Approvals

Approvals

Approvals

UL Listed / cUL Listed / cULus Listed

Ex Approvals

ATEX / UL Listed / cUL Listed / cULus Listed

Approvals submitted

Approval details

UL Listed

cUL Listed

cULus Listed

Resistance/potipotition transducer - MINI MCR-2-POT-UI - 2902016

Drawings

Block diagram

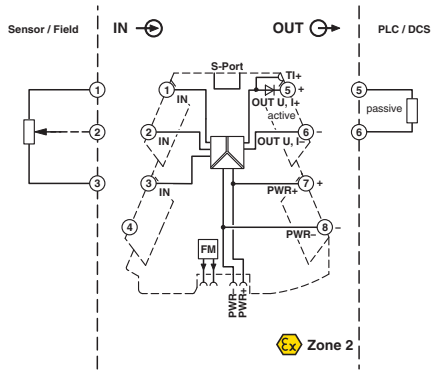

Pictogram

