

MA-12 AC
MA-12 DC

INSTALLATIONSANVISNING INSTALLATION MANUAL INSTALLATIONS ANLEITUNG

6012-2001

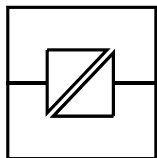

Galavanic
Isolation

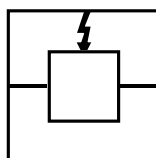

Transient
Protection

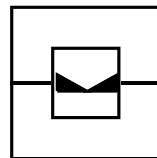

Balanced
Transmission

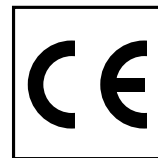

CE
Approved



*Korthållsmodem
Short haul modem
Kurzstreckenmodem*

 **westermo**[®]
www.westermo.se

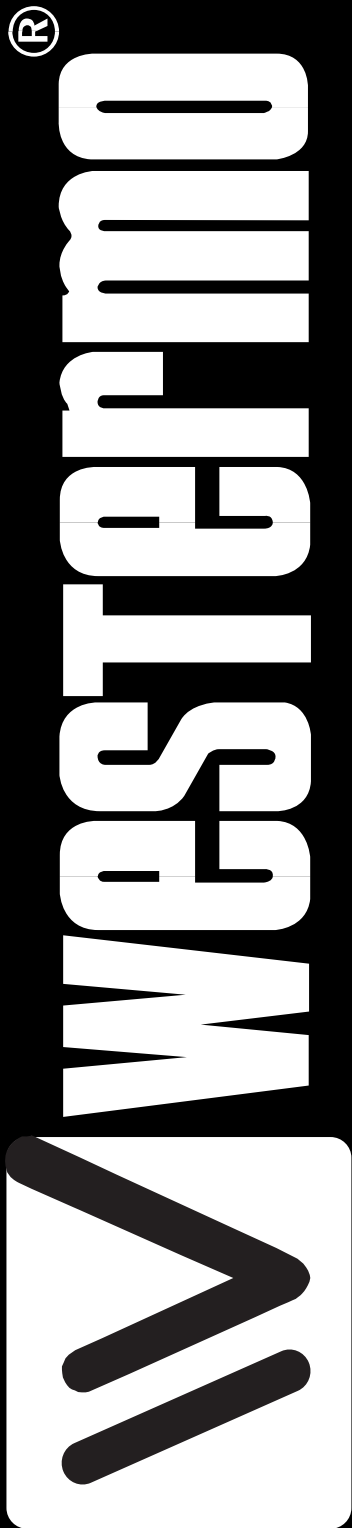

Specifications MA-12

Transmission	Asynchronous, full/half duplex or simplex
Interface 1	EIA RS-232-C/CCITT V.24/V.28 25-position D-sub female, DCE
Interface 2	±10mA balanced current loop
Data rate	Up to 38 400 bit/s
Indicators	Power, RD, DCD, RTS, TD
Isolation	Galvanic insulation with opto-coupler (data transmission) and transformer (supply)
Insulation voltage	1500V
Overvoltage protection	Nät: Breakdown voltage 440V at 230V AC and 220V at 115V AC Interface 2: Breakdown voltage transmitter 15V and receiver 5.8V Surge capacity 0.6 kW for 1 ms
Power supply	Switchable 115/230V +15/-10% 48-62Hz
Fuse	100 mA fast 5x20 mm
Power consumption	Max 4VA at 230V
Temperature range	5-50°C, ambient temperature
Humidity	0-95% RH, non-condensing
Dimensions	161x139x53 mm
Weight	0.5 kg
Mounting	With rubber pads or screws. Screws: Remove the two "keyholes" on the bottom of the case

Switch settings MA-12

The MA-12 can through different switch settings be adapted to a variety of running conditions. To set the switches, open the plastic case by placing and turning a screw-driver between top and bottom at the rear of the case.

Danger! Do not open connected unit

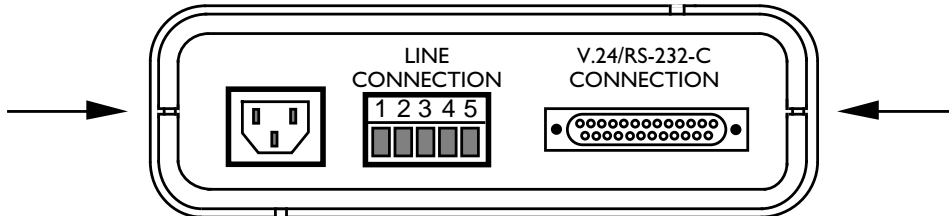

Switch settings

Transmitter (carrier) activated by

SI		Always active
SI		AUX
SI		SRS
SI		RFR
SI		RTS
SI		DTR
SI		DTR and AUX
SI		DTR and SRS
SI		DTR and RFR
SI		DTR and RTS

CTS controlled by

SI		RTS
SI		Always high
SI		DCD

Factory settings

S1 Selection of signal activating transmitter (carrier)
 Selection of signal controlling CTS

S2 Selection of power supply 115/230V AC

S2

S1

ON
OFF

Connections

Line connections

(5-pos. screw-terminal)

Direction	No.	Description
Receiver	1	R+
Receiver	2	R-
Transmitter	3	T+
Transmitter	4	T-
	5	Shield

Terminal connection (DCE)

(RS-232-C/V.24/V.28, 25-position D-sub, female)

Direction I)	Pin no.	CCITT V.24 Circuit number	Description
I	2	103	TD / Transmitted Data
O	3	104	RD / Received Data
I	4	105	RTS / Request to Send
O	5	106	CTS / Clear to Send
O	6	107	DSR / Data Set Ready
-	7	102	SG / Signal Ground
O	8	109	DCD / Data Carrier Detect
I	11	-	AUX / Auxiliary
I	19	120	SRS / Secondary Request to Send
I	20	108/2	DTR / Data Terminal Ready
I	25	133	RFR / Ready For Receiving

1) I = Input O = Output on MA-12

Line connection

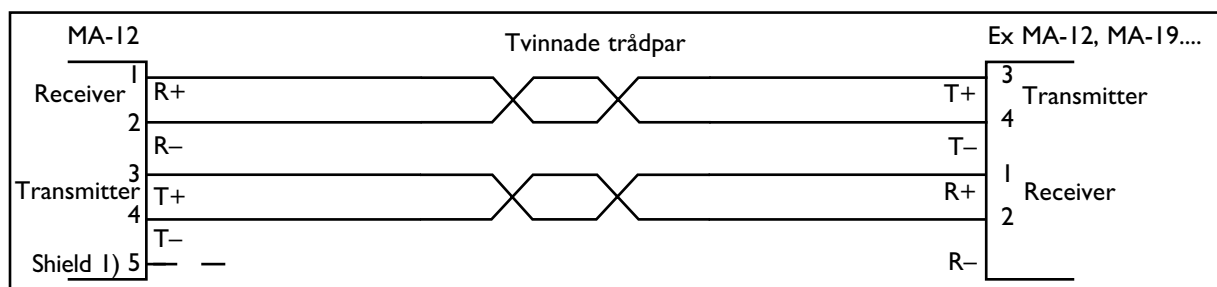

1) If shielded cable is used, connect the shield only at one end to avoid ground currents.

Transmission range (interface 2)

Cable	Transmission rate bit/s						
	600	1200	2400	4800	9600	19200	38400
42pF/m	18000 m	12000 m	8000 m	5000 m	2500 m	1000 m	500 m
0,3mm ²							

MA-12 DC

Specifications

Power supply	12-36V DC
Power consumption	Max 3W
Insulation	1000V
Fuse FI	1,6A fast 5x20 mm
All other specifications according to MA-12 AC	

Switch settings

According to MA-12AC

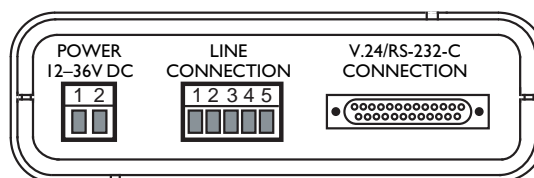

Anslutning

According to MA-12AC, except power supply

Connection no.	Power supply
1	+ Voltage
2	- Voltage

Hints

MA-12 are compatible with all asynchronous Westermo modem.

The RS-232 interface on the MA-12 is configured as DCE (Data Communication Equipment). Most printers, PC's and terminals are set as DTE (Data Terminal Equipment).

Some recommendation of cable configurations are given below.

If any problems do occur on set up of the MA-12, the LED's will be helpful.

- PWR: The unit has power.
- RD: Data received on line interface.
- TD: Data received on RS-232 interface.
- DCD: Carrier indication, must be on for transmission.
- RTS: Indicates the carrier control status.

A good way to check the MA-12 is to carry out a loop back test. Connect T+ to R+ and T- to R-. Connect the RS-232 port to a terminal. When keys are pressed on the terminal you should receive the echo on screen. The TD & RD lights will both flicker simultaneously as you press the keys.

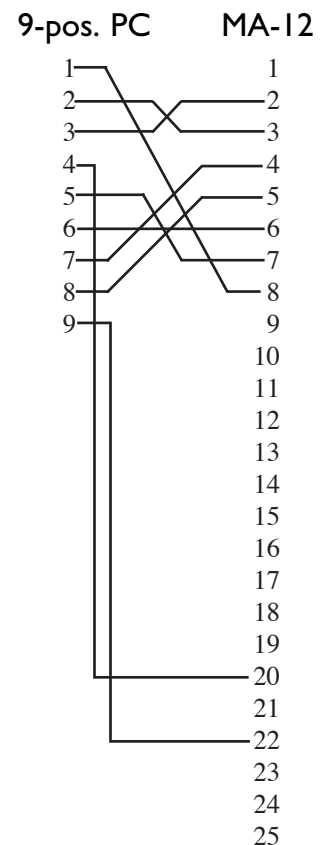
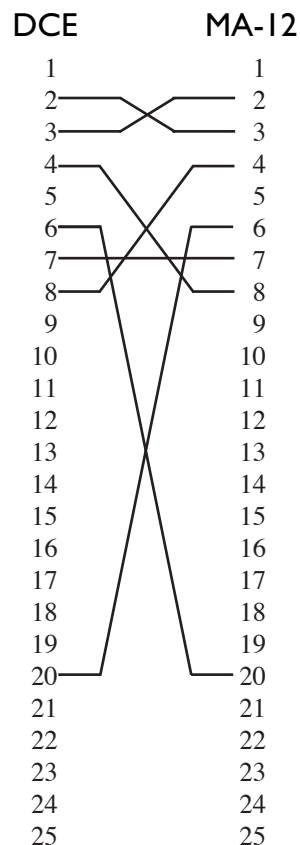
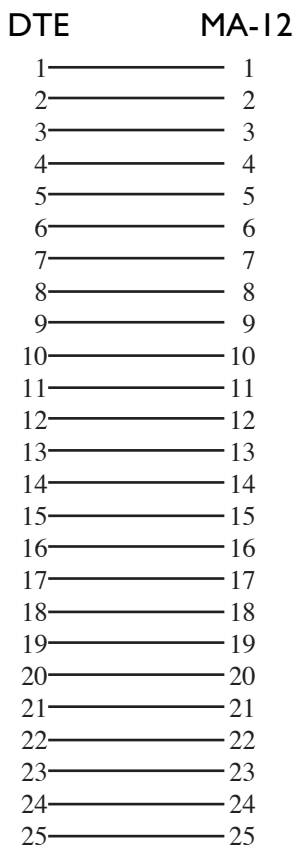
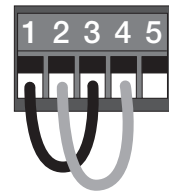

Block diagram

V.24/V.28/RS-232

Line

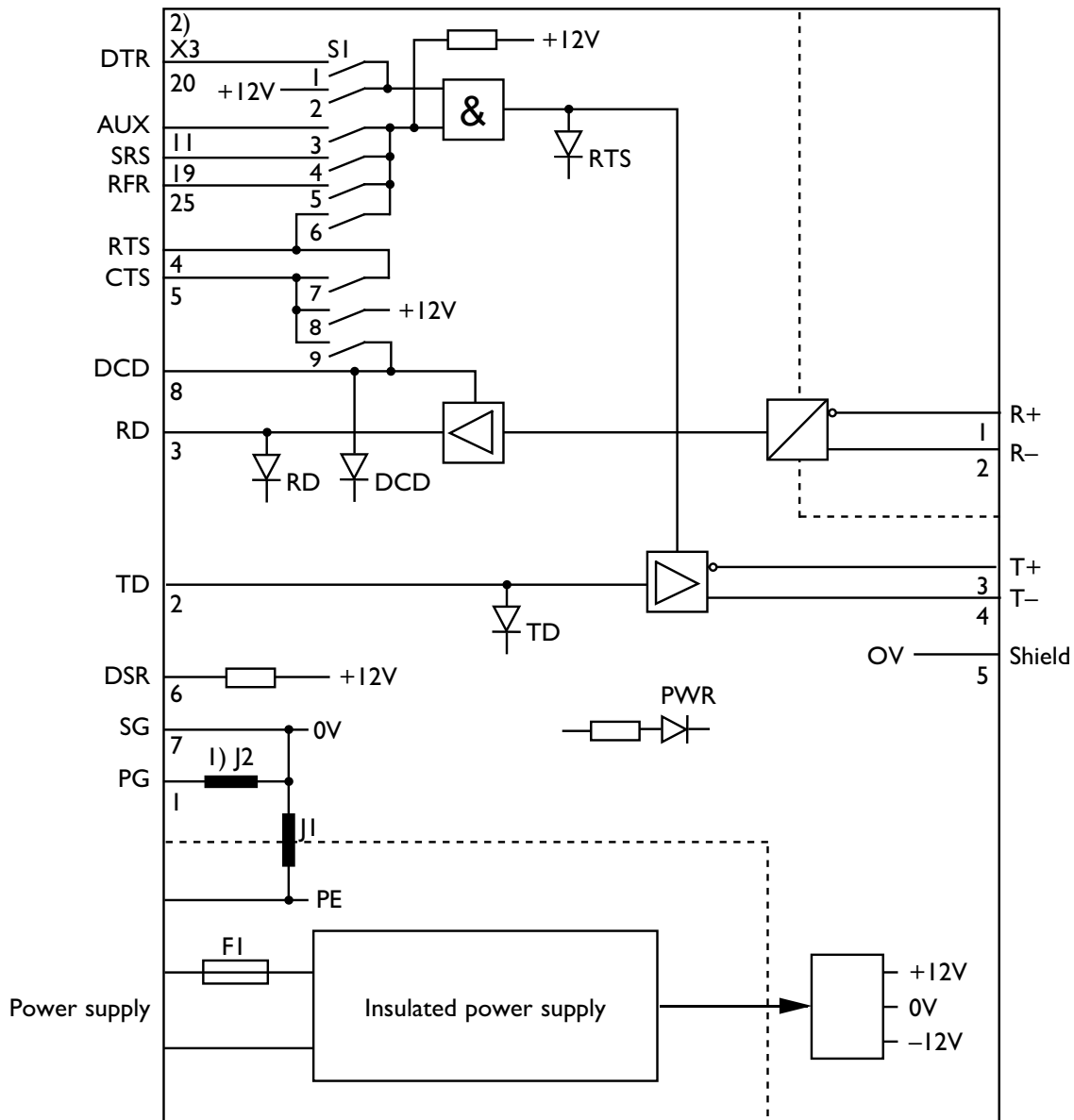

1) 0 Ω resistor J2 is normally not mounted 2) Metal housing on D-sub is connected to 0V

Westermo Teleindustri AB have distributors in several countries, contact us for further information.



Westermo Teleindustri AB • S-640 40 Stora Sundby, Sweden

Phone +46 16 612 00 Fax +46 16 611 80

E-mail: info@westermo.se • Westermo Web site: www.westermo.se

Subsidiaries

Westermo Data Communications Ltd
Solent Business Centre • Millbrook Road West
Millbrook, Southampton • SO15 0HW
Phone: +44(0)1703-704 611 • Fax: +44(0)1703 702 682
E-Mail: sales@westermo.co.uk

Westermo Data Communications GmbH
Bruchsaler Straße 18, 68753 Waghäusel
Tel.: +49(0)7254-95400-0 • Fax: +49(0)7254-95400-9
E-Mail: westermo.germany@t-online.de