

Extension module - PSR-SPP- 24DC/TS/SDI8/SDIO4 - 2986041

Please be informed that the data shown in this PDF Document is generated from our Online Catalog. Please find the complete data in the user's documentation. Our General Terms of Use for Downloads are valid (<http://download.phoenixcontact.com>)



PSR-TRISAFE-M input/output extension module with 8 safe inputs and 4 safe, configurable channels (choice of safe inputs or outputs), 2 clock/alarm outputs; up to SILCL 3, Cat.4/PL e, SIL 3, EN 50156, plug-in spring-cage connection terminal blocks

The figure shows a version with a screw connection

Why buy this product

- ✓ Flexible extension with safe inputs and outputs
- ✓ Narrow 22.5 mm housing
- ✓ 4 safe digital outputs or 4 additional digital inputs (that can be configured using SAFECONF)
- ✓ Multifunctional use for a wide range of safety functions
- ✓ Easy graphical configuration instead of complex programming
- ✓ Quick startup thanks to user-friendly simulation and test options
- ✓ Including PSR-TBUS connector (DIN rail connector) for adapting to the PSR-TRISAFE-M master module
- ✓ Up to Cat. 4/PL e according to ISO 13849-1, SILCL 3 according to IEC 62061, SIL 3 according to IEC 61508
- ✓ 8 safe digital inputs
- ✓ 2 alarm outputs or 2 clock outputs (that can be configured using SAFECONF)
- ✓ EN 50156



Key commercial data

Packing unit	1 pc
GTIN	4 046356 451369
Weight per Piece (excluding packing)	99.99 g
Custom tariff number	85389091
Country of origin	Germany

Technical data

Note:

Utilization restriction	EMC: class A product, see manufacturer's declaration in the download area
-------------------------	---

Dimensions

Extension module - PSR-SPP- 24DC/TS/SDI8/SDIO4 - 2986041

Technical data

Dimensions

Width	22.5 mm
Height	112 mm
Depth	114.5 mm

Ambient conditions

Ambient temperature (operation)	-20 °C ... 55 °C
Ambient temperature (storage/transport)	-20 °C ... 70 °C

Input data

Nominal input voltage U_N	24 V DC (A1 / A2)
Input voltage range in reference to U_N	0.85 ... 1.1
Typical input current at U_N	100 mA
Maximum response time	< 30 ms
Bypassing voltage dips	20 ms
Recovery time	< 10 s
Protective circuit	Surge protection Suppressor diode
Status display	2 LEDs (green, red)
Number of safe inputs	12 (of which 4 can be configured as input or output)
Nominal voltage U_N	24 V DC
Typical current consumption	4 mA
Signal level "0" signal	< 5 V
Signal level "1" signal	> 11 V
Permissible cable length	2000 m
Error detection time at 1-channel structure	< 1 s
Status display	12 LEDs (green)

Output data

Contact type	8 safe digital inputs
	4 safe digital outputs
	4 safe digital inputs
	2 clock outputs
	2 alarm outputs
Number of safe semiconductor outputs	4 (If the four parameterizable inputs/outputs are used as outputs)
Nominal voltage U_N	24 V DC
Limiting continuous current	4x 0.5 A (see derating curve)
Max. capacitive load	1 μ F (When using electromechanical components (e.g. safeguarding), the capacitive load can be disregarded.)
Max. inductive load	(A suitable and effective protective circuit is to be provided for inductive loads. A recommended measure is the use of free-wheeling diodes.)
Test pulses	< 1 ms
Cycle/alarm outputs	<p></p>
Number of outputs	2
Nominal voltage U_N	24 V DC

Extension module - PSR-SPP- 24DC/TS/SDI8/SDIO4 - 2986041

Technical data

Output data

Limiting continuous current	50 mA
Test pulses	~ 1 ms

General

Mounting position	Horizontal
Category according to EN 13849-1	4
Name	Air and creepage distances between the power circuits
Standards/regulations	DIN EN 50178
Rated surge voltage / insulation	0.8 kV / Basic isolation
Rated insulation voltage	50 V
Pollution degree	2
Surge voltage category	III
Housing material	Polyamide PA non-reinforced
Interfaces	DIN rail TBUS for connection to the master module, supplied as standard

Connection data

Conductor cross section solid min.	0.2 mm ²
Conductor cross section solid max.	1.5 mm ²
Conductor cross section stranded min.	0.2 mm ²
Conductor cross section stranded max.	1.5 mm ²
Conductor cross section AWG/kcmil min.	24
Conductor cross section AWG/kcmil max	16
Stripping length	8 mm
Connection method	Spring-cage connection

Classifications

eCl@ss

eCl@ss 4.0	27371102
eCl@ss 4.1	27371102
eCl@ss 5.0	27371901
eCl@ss 5.1	27371901
eCl@ss 6.0	27371819
eCl@ss 7.0	27371819
eCl@ss 8.0	27371819

ETIM

ETIM 2.0	EC001449
ETIM 3.0	EC001449
ETIM 4.0	EC001449
ETIM 5.0	EC001449

Extension module - PSR-SPP- 24DC/TS/SDI8/SDIO4 - 2986041

Classifications

UNSPSC

UNSPSC 6.01	30211901
UNSPSC 7.0901	39121501
UNSPSC 11	39121501
UNSPSC 12.01	39121501
UNSPSC 13.2	39121501

Approvals

Approvals

Approvals

UL Listed / GOST / cUL Listed / Functional Safety / cULus Listed

Ex Approvals

Approvals submitted

Approval details

UL Listed

GOST

cUL Listed

Functional Safety

cULus Listed

Accessories

Accessories

Extension module - PSR-SPP- 24DC/TS/SDI8/SDIO4 - 2986041

Accessories

Adapter cable

USB cable - CABLE-USB/MINI-USB-3,0M - 2986135



USB connecting cable: USB plug type A to USB plug type Mini-B; length: 3 m

Configuration set

Configuration package - PSR-SAFECONF-BOX-EN - 2986164



Configuration package for the PSR-TRISAFE safety module, consisting of the SAFECONF software, connecting cable and Quick Start Guide.

Configuration package - PSR-SAFECONF-BOX-DE - 2986151



Configuration package for the PSR-TRISAFE safety module, consisting of the SAFECONF software, connecting cable and Quick Start Guide.

DIN rail connector

Cable - ME 22,5 TBUS 1,5/ 5-ST-3,81 GN - 2707437



DIN rail connector for DIN rail mounting. Universal for TBUS housing. Gold-plated contacts, 5-pos.

Electronic housing - PSR-TBUS - 2890425



DIN rail connector for safety switching devices, for supplying/controlling/monitoring (depending on the module)

Gateways/Proxies

Extension module - PSR-SPP- 24DC/TS/SDI8/SDIO4 - 2986041

Accessories

Data interface - EM-PB-GATEWAY-IFS - 2297620



The PROFIBUS module EM-PB-GATEWAY-IFS, certified as per DPV1 specification (EN 50170), connects up to 32 motor management modules (EMM-...IFS) or other INTERFACE system devices via the TBUS DIN rail connector.

Memory block

Memory block - IFS-CONFSTICK - 2986122



Multi-functional memory block for the INTERFACE system for easy storage and backup of the configuration.

Solid-state contactor

Filter terminal block - PSR-FTB/20/86 - 2904477



Terminal block for filtering test pulses of safe semiconductor outputs, plus EMI filtering of 24 V signals up to a current strength of 2 A

Filter terminal block - PSR-FTB/1.5/11.5 - 2904476



Terminal block for filtering test pulses of safe semiconductor outputs, plus EMI filtering of 24 V signals up to a current strength of 2 A

Starter kit

Starter kit - ILC 130 SBT V2 STARTERKIT - 2700993



ILC 130 SBT starter kit including ILC 130 ETH, LPSDO and PSDI SafetyBridge modules, control panel, power supply unit, and accessories with pre-configured safety application

Drawings

Extension module - PSR-SPP- 24DC/TS/SDI8/SDIO4 - 2986041

Connection diagram

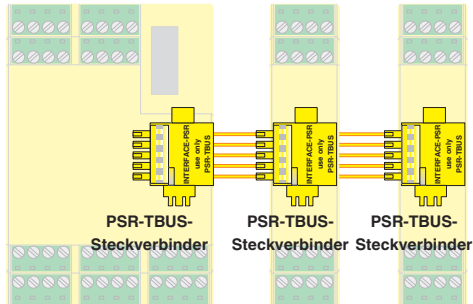

Circuit diagram

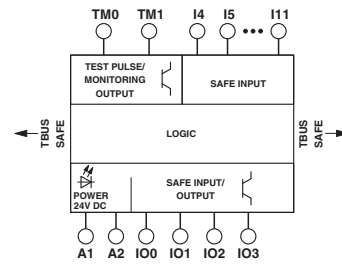

PSR-TBUS DIN rail connectors are used for cross-wiring between the modules.