

MALE END VIEW

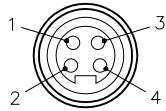

- 1 = BROWN
- 2 = WHITE
- 3 = BLUE
- 4 = BLACK



SPECIFICATIONS

|                                   |                                   |
|-----------------------------------|-----------------------------------|
| CONTACT CARRIER MATERIAL          | TPU                               |
| MOLDED HEAD MATERIAL/COLOR        | TPU/YELLOW                        |
| CONTACT MATERIAL/PLATING          | BRASS/GOLD                        |
| COUPLING NUT MATERIAL/PLATING     | BRASS/NICKEL                      |
| RATED CURRENT [A]                 | 9.0 A                             |
| RATED VOLTAGE [V]                 | 600 V                             |
| OUTER CABLE JACKET MATERIAL/COLOR | PVC/YELLOW                        |
| CONDUCTOR INSULATION MATERIAL     | PVC                               |
| NUMBER OF CONDUCTORS [AWG]        | 4x18 AWG                          |
| TEMPERATURE RANGE                 | -40°C to +105°C (-40°F to +221°F) |
| PROTECTION CLASS                  | MEETS NEMA 1,3,4,6P AND IEC IP67  |

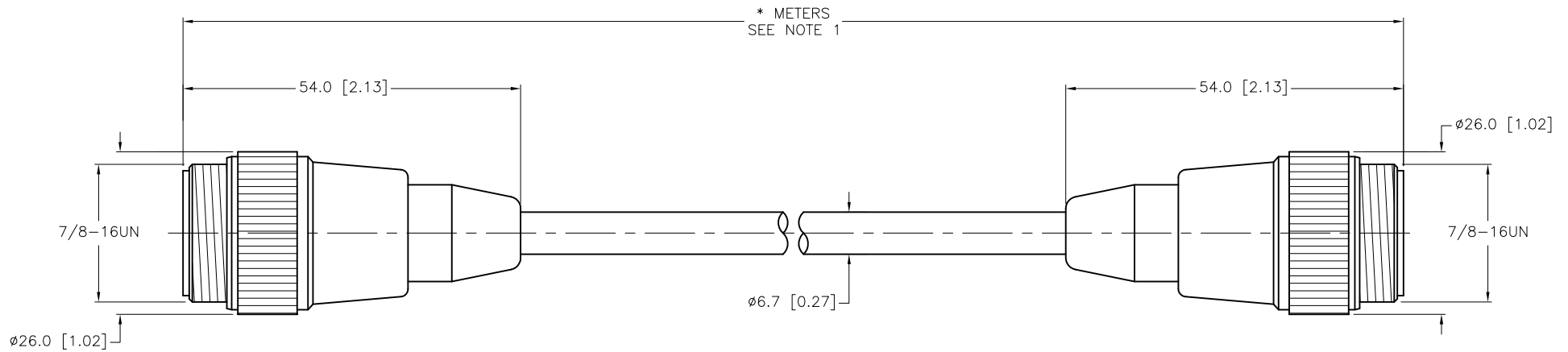

| CABLE LENGTH | TOLERANCE   |
|--------------|---|
| ALL LENGTHS  | + 4% (OR 50mm) OF LENGTH<br>- 0% (OR 0mm) OF LENGTH<br>WHICHEVER IS GREATER |
| STRIP LENGTH | TOLERANCE   |
| 0-7mm        | ±0.5mm  |
| 8-29mm       | ±1.0mm  |
| 30-49mm      | ±2.0mm  |
| 50-69mm      | ±3.0mm  |
| 70-100mm     | ±4.0mm  |
| OVER 100mm   | ±5.0mm  |

NOTES:

1. "\*" INDICATES CABLE LENGTH IN METERS. CONTACT TURCK TO ORDER SPECIFIC LENGTHS.

SOURCE DRAWING - FOR REFERENCE ONLY

|   |                          |  |     |  |          |                    |               |
|---|--------------------------|--|-----|--|----------|--------------------|---------------|
| RELATED DOCUMENTS<br>1.<br>2.<br>3.<br>4. | 3RD ANGLE PROJECTION<br> | THIS DRAWING IS CONFIDENTIAL AND THE PROPERTY OF TURCK INC. USE OF THIS DOCUMENT WITHOUT WRITTEN PERMISSION IS PROHIBITED. |     | <b>TURCK INC</b><br>High Technology Sensors and Automation Controls<br>3000 CAMPUS DRIVE<br>MINNEAPOLIS, MN 55441<br>1-800-544-7769<br>(763) 553-7300<br>(763) 553-0708 fax<br>turck.com |          |                    |               |
|   |                          | DRFT   | RWC | DATE   | 04/02/10 | DESCRIPTION        | RSM RSM 40-*M |
| MATERIAL                                  | SEE SPECIFICATIONS       | APVD   |     | SCALE  | 1=1.0    | IDENTIFICATION NO. |               |
| FINISH                                    | SEE SPECIFICATIONS       | UNIT OF MEASUREMENT  |     | MILLIMETER [ INCH ]  |          | REV                | A             |
|   |                          | CONTACT TURCK FOR MORE INFORMATION   |     | DO NOT SCALE THIS DRAWING  |          | FILE: 777001756    | SHEET 1 OF 1  |

|     |                                       |     |          |         |
|-----|---------------------------------------|-----|----------|---------|
| A   | DRAWING RELEASE & PROCESSED ECO 37149 | KMY | 01/19/12 |         |
| REV | DESCRIPTION                           | BY  | DATE     | ECO NO. |