

10034814-001LF - SATA : 22
Position Right Angle Surface
Mount Receptacle



www.fci.com

Specifications

General	
Number of contacts	22
Orientation	Right Angle
Retention Feature	Fork Lock/Harpoon
Electrical	
Current rating	1.5A at 30°C
Resistance (Contact)	15 M-ohms max.
Resistance (Insulation)	1000 M-ohms min.
Voltage rating	500V AC
Mechanical	
Durability (Mating cycles)	500 Mating Cycles
Mounting	
Termination	Surface Mount
Physical	
Color (Housing)	Black
Material (Contact)	Copper Alloy
Material (Housing)	Thermoplastic (UL 94 V-O)
Plating (Contact)	30u" Gold
Temperature (Operating - range)	260°C max. for 10 Seconds
Approvals / Certifications	
Approvals / Certifications	UL and CSA Pending
Other Features	
Packaging (Type)	Tray
Type	Combo Receptacle

PRODUCT NO.	RECOMMENDED P.C.B. THICKNESS
10034814-001LF	1.6MM

A

B

C

D

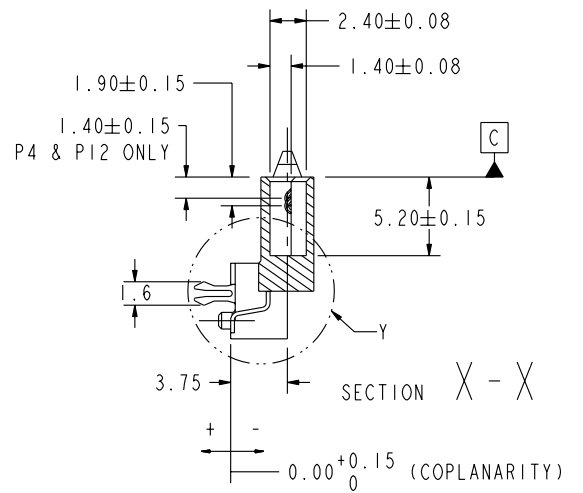
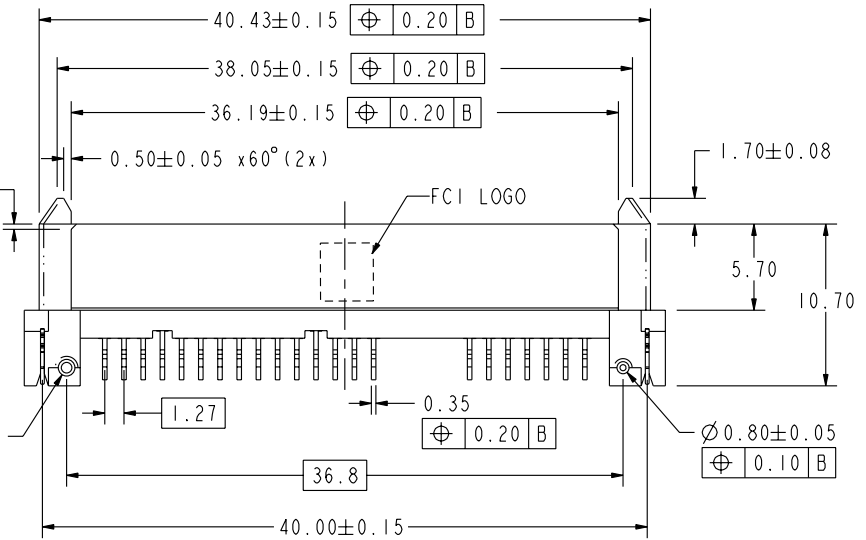
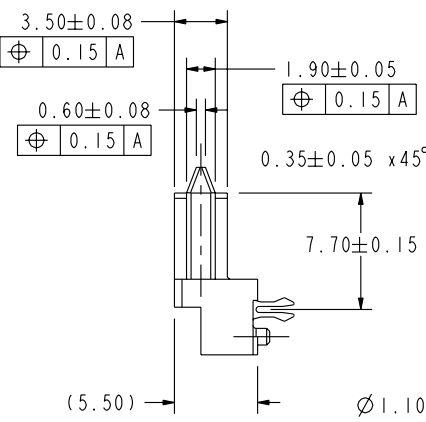
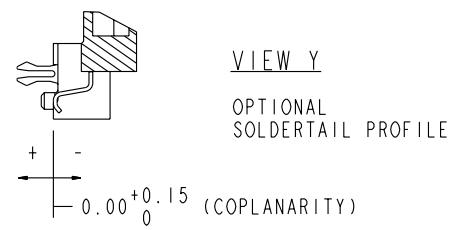
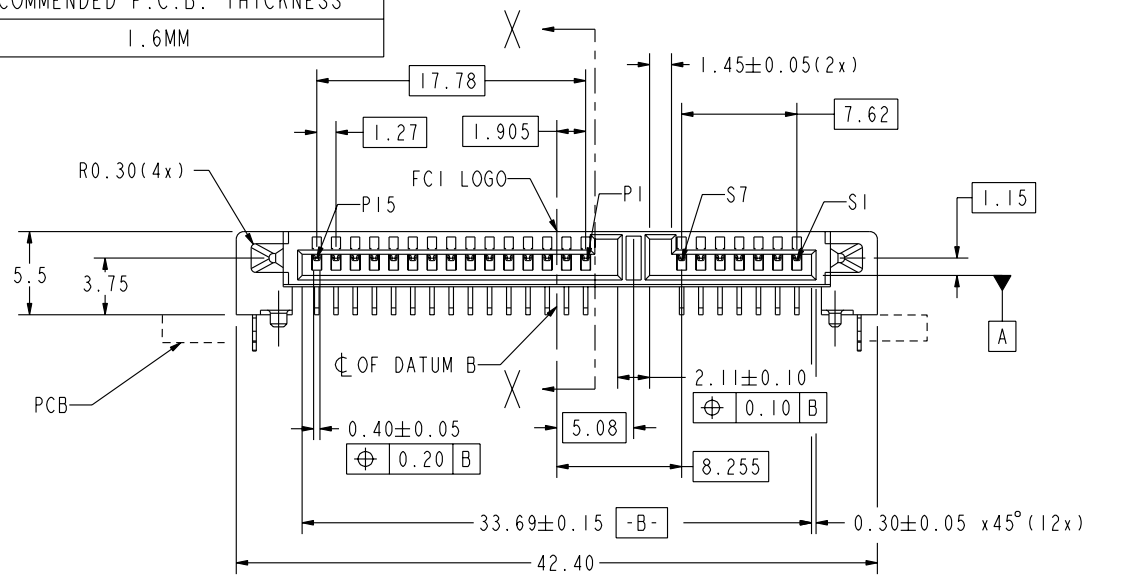

Copyright FCI.

rev	ecn no	dr	date
A	S04-0177	JPEH	2004-08-23
B	S04-0193	LWH	2004-09-20
C	S05-0032	YEO	2005-02-03
D	S07-0049	CWL	2007-02-14
-	-	-	-
-	-	-	-
-	-	-	-

www.fciconnect.com		surface - ✓ ASME Y14.5	tolerance std ASME Y14.5	projection MM
		TOLERANCES UNLESS OTHERWISE SPECIFIED		MM
Dr	JPEH	2004-08-28	ANGULAR	size A4
Eng	WL CHOONG	2007-02-14	LINEAR	Scale 2:1
Chr	WL CHOONG	2007-02-14	2° ±	ECN S07-0049
Appr	JOEY NG	2007-02-14	Product family	Spec ref
		S-ATA COMB RECEPTACLE		dwg no 10034814
		R/A SMT TYPE ASSY		Rev. D
		catalog no	CUSTOMER	sheet 1 of 2

REV F - 2006-04-17

A

B

C

D

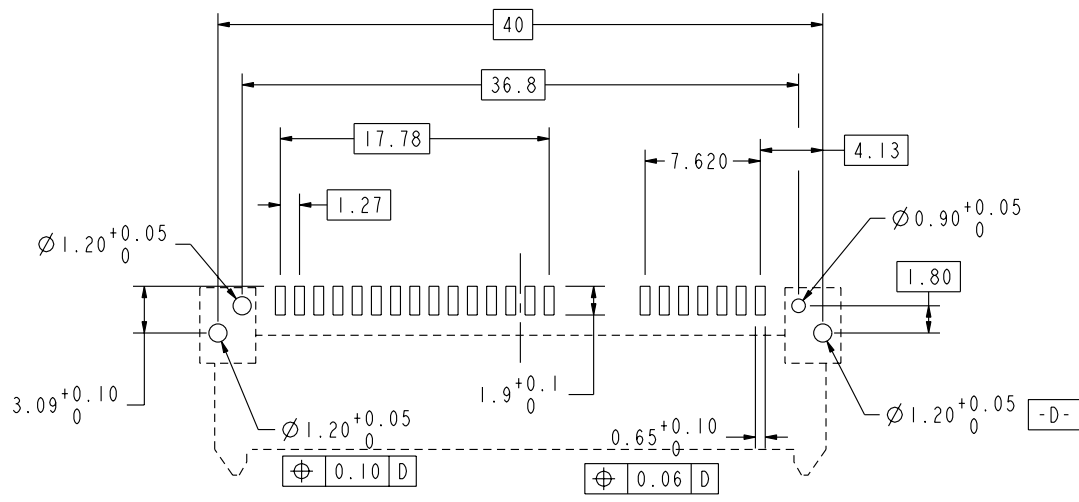

RECOMMENDED P.C.B. LAYOUT
 TOLERANCE UNLESS OTHERWISE : ± 0.1

NOTES:-

1. MATERIAL:
 - 1) HOUSING : HIGH TEMP. THERMOPLASTIC, UL 94V-0
 - COLOR : BLACK
 - 2) TERMINAL : COPPER ALLOY
 - 3) HOLD DOWN : COPPER ALLOY
2. FINISH:
 - 1) TERMINAL : 30u" Au PLATING (CONTACT POINT) OVER 50u" MIN NICKEL
 - 2) SOLDER TAIL : 100u" MIN TIN OVER 50u" NICKEL
 - 3) HOLD DOWN : 100u" MIN TIN OVER 50u" NICKEL
3. TRUE POSITION APPLY AT TERMINAL TIP
4. THE STANDARD PACKAGING IS IN TRAY.
5. THE HOUSING WILL WITHSTAND EXPOSURE TO 260°C PEAK TEMPERATURE FOR 10 SECONDS IN A CONVECTION, INFRA-RED OR VAPOR PHASE REFLOW OVEN
- ⑥ THIS PRODUCT MEETS EUROPEAN UNION DIRECTIVES AND OTHER COUNTRY REGULATIONS AS DESCRIBED IN GS-22-008
- ⑦ PART NUMBERS ENDING IN "LF" ARE MEANT FOR LEAD-FREE IDENTIFICATION. P/N XXXXXXXX-XXXLF IS EQUIVALENT TO PREVIOUS P/N XXXXXXXX-XXX

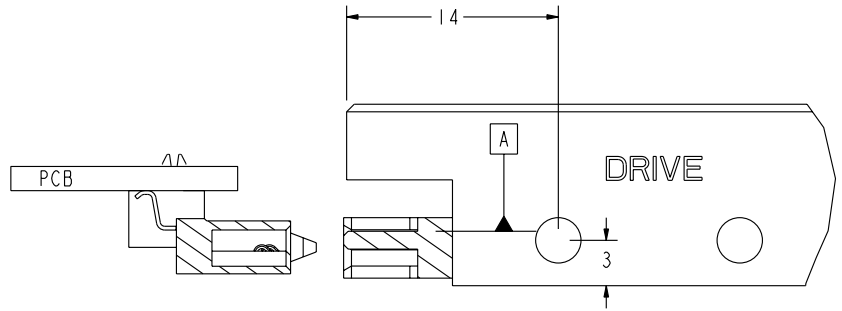

S-ATA Connector mounting view



Copyright FCI.

	title S-ATA COMB RECEPTACLE R/A SMT TYPE ASSY	dwg no 10034814	Rev. D
	catalog no	CUSTOMER	sheet 2 of 2