



ENGLISH

Datasheet

Stock No: 257-149

# RS Pro Liquid Acetal Copolymer 4.5 → 16 V dc Sensor/Switch without Indicator, 20bar Pressure



## Liquid Flow Sensors

Two flow transducers manufactured in acetal copolymer with brass compression fittings at both ends to fit 15mm diameter pipe connections.

Provides a pulsed output proportional to flow rate

LED and photodetector are separated by a turbine mounted on sapphire bearings

LED requires an external current limiting resistor (dependent on supply voltage)

Suitable for use with mains and heating system waters etc.

Rise/fall times 60/6ns

Output voltage 200mV (low);  $V_{CC}$  (high)

Diode: Forward current 10mA, Power dissipation 100mW

## Note

Not suitable for use with strong mineral acids/solutions, strong or searching solvents.

①

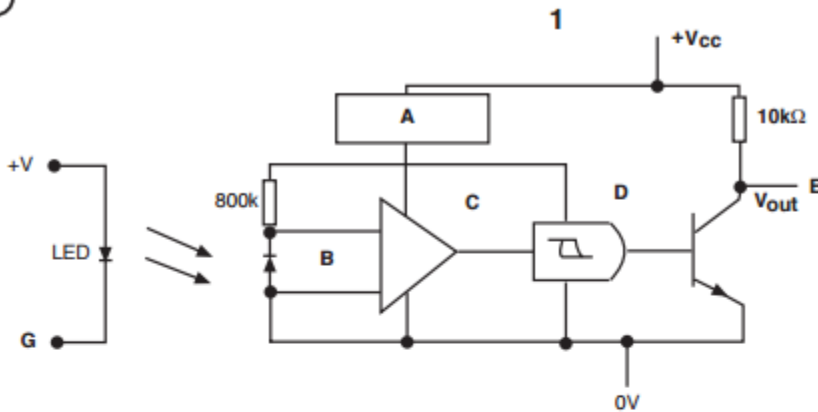

2

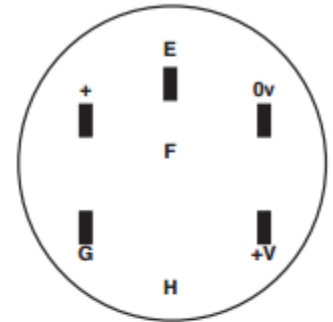

GB

1. **Electrical**  
(with logic chip detector)
- A. Voltage regulator
- B. Photo diode
- C. Amplifier
- D. Schmitt trigger
2. **Electrical connection**
- E. Output
- F. Photodetector
- G. Cathode
- H. Diode

D

1. **Elektrische Bauteile (mit Detektorlogik)**
- A. Spannungsregler
- B. Fotodiode
- C. Verstärker
- D. Schmitt-Trigger
2. **Elektrische Anschlüsse**
- E. Ausgang
- F. Fotodetektor
- G. Kathode
- H. Diode

E

1. **Sistema Eléctrico (con detector de chip lógico)**
- A. Regulador de tensión
- B. Fotodiodo
- C. Amplificador
- D. Disparador de Schmitt
2. **Conexión eléctrica**
- E. Salida
- F. Fotodetector
- G. Cátodo
- H. Diodo

I

1. **Elettrico**  
(con rilevazione logica chip)
- A. Regolatore di tensione
- B. Fotodiodo
- C. Amplificatore
- D. Trigger Schmitt
2. **Collegamento elettrico**
- E. Uscita
- F. Fotorivelatore
- G. Catodo
- H. Diodo

②

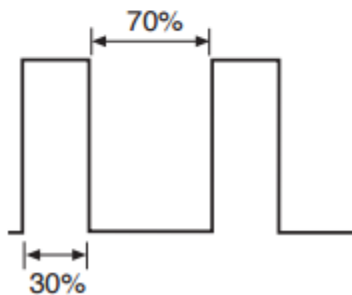

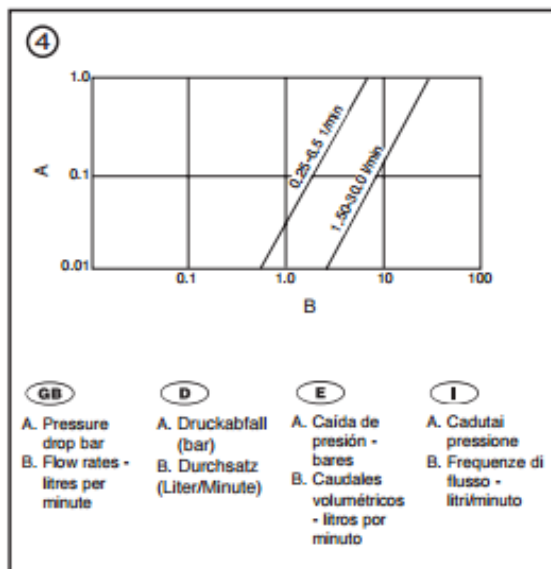
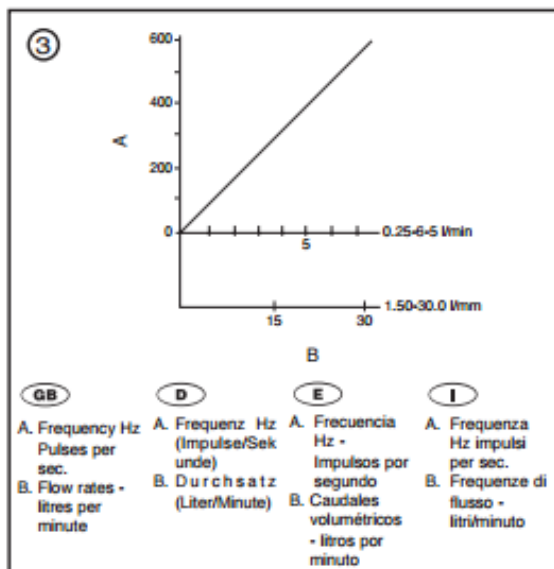

**GB** **RS Stock No.**  
257-133 and 257-149

**General**

These flow transducers have been designed for use with mains and heating system waters. Subject to customer evaluation, it may also be possible to use them with demineralised water, neutral or dilute alkaline solutions, hydrocarbon or mild oxy-hydrocarbon solvents (including light fuel oils and spirits) and dilute, weak organic acids depending on concentration. (generally up to 5% at ambient temperature is acceptable) and temperature. It is not possible to use these flow transducers with strong mineral acids or acid solutions at any temperature or dilution, nor with strong or searching solvents (e.g. methylene chloride, acetone, alcohols, chloroform).

**Installation**

Before installation check the free running of the sensor by blowing through it. DO NOT USE AN AIR LINE. Ideally the flowsensor should be installed with the arrow on the turbine housing pointing vertically upwards. The unit may, however, be installed in any attitude providing the pipes are full of liquid. Pockets of vapour or bubbles of air will affect some of the light and so alter the number of pulses recorded from the sensor. On the lower flow model these bubbles may take some time to clear because of the low fluid velocities inside the chamber. A large back pressure will reduce any tendency the liquid has to form vapour pockets. As the detection system is optical it is undesirable to install the flow sensor near a strong light source or in direct sunlight, as this may 'swamp' the detection system.

**Pumps**

All pumps cause pulsations in the fluid, centrifugal pumps have probably the lowest disturbance, and reciprocating pumps the largest. With a centrifugal pump the pulsations reduce after a fairly short pipe run so if the flow sensor is positioned as far from the pump as possible, the effects will be minimised. With reciprocating pumps more positive isolation is desirable and a pulse damper or accumulator is probably required. If pulsations cannot be removed the unit must be recalibrated over the desired flow range.

**Considerations**

All flow sensors should only be installed with the following in mind: bends, valves, flow regulators, tee junctions and other fittings which cause the flow to travel faster at one side of the pipe relative to the other. This asymmetry in the flow can seriously affect the calibration and the disturbance should be as far removed from the sensor as possible and if at all practical, put after the flow sensor. Recalibration on site will, of course, remove any doubt about the installation. In all cases an 80 mesh filter should be fitted upstream of the flow sensor.

**Viscosity**

Viscosity effects:- all turbine transducers are affected by viscosity and where possible the viscosity (temperature) of the liquid should be kept fairly constant. Viscous drag causes the turbine to be slowed down quicker at the lower flows, as viscosity increases so does the threshold to operation. If the fluid is lubricating and a higher pressure drop is acceptable, the turbine can be run at up to 50% over range with no detrimental effects.

**Electronic**

Inside the housing is an infra-red light emitting diode. The LED is directed at the receiver which has a built-in voltage regulator, photo diode, amplifier, schmitt trigger and output stage. Every turbine blade passage blocks the light beam and so reduces the level of the output signal to typically 200mV (maximum 400mV). The 'unblocked' level is the supply voltage and the output is tied to this through a 10k resistor. The output rise and fall times are typically 60ns and 8ns respectively. At the maximum continuous operating temperature (70°C) the power dissipation of the detector output stage is 2.5mW, care must therefore be taken not to overload the output. At ambient temperatures the unit can dissipate up to 250mW.

The power to the LED is dependent on supply current, and this MUST be limited with a series resistor and potentiometer. Current required is subject to optical density of medium being measured. Maximum recommended current = 30mA.

**Diode****Absolute Maximum Ratings**

Reverse voltage @ 25°C free air temperature	3.0V
Continuous forward current at (or below ) 25°C free air temperature	60mA
Recommended current	30mA
Operating free air temperature range	-40°C to 70°C
Storage temperature range	-40°C to 70°C
Lead temperature 1.6mm from case for 5 sec.	260°C
Power dissipation	100mW

**Photodetector****(Typical)**

Max. dissipation	250mW @ 25°C
Operating supply voltage	4.5 to 16Vd.c. supply (Vcc)
Output low	6mA
Supply current	7mA
Output high	0.4mA
Supply current	5mA
Output voltage low	0.2V
Output voltage high	Vcc
Rise time	60ns
Fall time	6ns

**Note:** At the maximum continuous operating temperature (70°C) the power dissipation of the detector output stage is 2.5mW. Care must therefore be taken not to overload the output.

The pulses from the sensor when viewed on an oscilloscope should look like the central drawing in Figure 2. If the LED current is too high, an increase in ambient light levels could cause the signal to stay high. A 50-50 mark space ratio is not possible as the blades are thinner than the spaces.

Figures 3 and 4 show results of flowtransducers calibrated on a gravimetric flow rig. The differential pressure is set using a rising mercury manometer. Water temperature 8°C

Colour Code	Grey Body (RS stock no. 257-149)	Beige Body (RS stock no. 257-133)
Flow Range	0.25-6.5 l/m	1.50-30.0 l/m
Linearity at FSD Frequency	±1.0%	±1.5%
Approximate Full Scale At Full Scale	500Hz	600Hz
Approximate Pulses per Litre	4600 pulses/litre	1200 pulses/litre

**Standard materials of construction**

Body	- Acetal copolymer
Retaining Cap	- Acetal copolymer
Rotor	- Acetal copolymer
Rotor housing	- Clear nylon
Spindle	- Stainless steel
Bearings	- Sapphire
O' Ring	- Nitrile rubber

**Standard connections**

15mm Cu x 15mm Cu (compression fittings)

**Operation pressure**

Max. 300lbs/sq ins

**Dimensions mm**

Length	=	89 (over fittings)
Height	=	51
Breadth	=	37

RS Components shall not be liable for any liability or loss of any nature (howsoever caused and whether or not due to RS Components' negligence) which may result from the use of any information provided in RS technical literature.