

Instruction Manual ISA830/ISA830TG 3.0GHz Spectrum Analyzer

EN FR



Table of Contents

Table of Contents	3
SAFETY INSTRUCTIONS	7
Safety Symbols	7
Safety Guidelines	7
GETTING STARTED	11
ISA830/ISA830TG Characteristics	12
Package Contents	13
Front Panel Overview.....	14
Rear Panel Overview	18
Display Overview.....	21
Tilt Stand & Power Up.....	24
Error Check.....	26
Functionality Check.....	27
QUICK REFERENCE	29
Operation Shortcuts	30
Menu Tree.....	36
Preset Contents.....	50
FREQUENCY/SPAN	51
View Signal (Center and Span)	52
View Signal (Start and Stop).....	55
Full/Zero Span	58
Recall the Last Span Setting	59
AMPLITUDE	60
Set Vertical Scale	61
Amplitude Correction.....	67
Set Input Impedance	73
AUTOSET	75
How Autoset Works.....	76
Run Autoset	78
Limit vertical search range.....	79
Limit horizontal view range	80
MARKER	81
Activate/de-activate marker	82

Move marker	85
Show Markers in Table	89
PEAK SEARCH.....	91
Search Signal Peak	92
Show Peak Table	96
TRACE	100
View traced waveform	101
Move Marker to Trace	104
Run Trace Math	106
Select Signal Detection Mode	109
POWER MEASUREMENT	112
ACPR Measurement.....	113
OCBW Measurement.....	116
NdB Measurement.....	119
Phase Jitter Measurement.....	120
LIMIT LINE	122
Edit Limit Line.....	123
Run Pass/Fail test.....	127
BANDWIDTH.....	129
Select RBW (Resolution BandWidth)	130
Select VBW (Video BandWidth).....	131
RBW/VBW Auto Mode Contents.....	132
Set Sweep time	134
Average Waveform	134
TRIGGER	137
Select Trigger Type.....	138
Select Trigger Mode.....	139
Set Trigger Delay	141
DISPLAY	142
Change Display Brightness	143
Activate Display Line	143
Enter Display Title	144
Use Split Display	145
Use VGA Output	147
Save Display Image to USB Flash Drive.....	147
FILE.....	150







File Location and File Type.....	151
Copy File.....	152
Delete File.....	157
Rename File.....	159
Save Display Image to USB Flash Drive.....	161
PRESET.....	164
SYSTEM.....	165
Save/Recall Panel Setting.....	166
Configure Communication Interface.....	168
View System Information.....	169
Set Date/Time.....	175
Synchronize ISA830/ISA830TG with Other Devices.....	176
Select Language.....	178
Use Auxiliary Signal.....	179
Enter Service Operation.....	179
SEQUENCE.....	180
Edit Sequence.....	181
Run Sequence.....	186
TRACKING GENERATOR (ISA830TG).....	188
DC Operation.....	191
PC SOFTWARE.....	192
Install Software.....	193
Connect Software.....	194
Use Software.....	197
REMOTE CONTROL.....	201
Configure Interface.....	203
Command Syntax.....	204
Status Registers.....	206
Command Set.....	210
FAQ.....	222
Appendix.....	223
ISA830/ISA830TG Specifications.....	223
Optional Items Specifications.....	226

SAFETY INSTRUCTIONS

This chapter contains important safety instructions that you must follow when operating the ISA830/ISA830TG and when keeping it in storage. Read the following before operating this instrument to ensure your safety and to keep the ISA830/ISA830TG in best condition.

Safety Symbols

These safety symbols may appear in this manual or on the ISA830/ISA830TG.

 WARNING	Warning: Identifies conditions or practices that could result in injury or loss of life.
 CAUTION	Caution: Identifies conditions or practices that could result in damage to the ISA830/ISA830TG or to other properties.
	DANGER High Voltage
	Attention Refer to the Manual
	Protective Conductor Terminal
	Earth (ground) Terminal

Safety Guidelines

General Guideline



CAUTION

- Make sure that the RF input level and the Tracking Generator output reversed power level do not exceed +30dBm.
- Do not supply an input signal to the Tracking Generator output.
- Do not place any heavy object on the ISA830/ISA830TG.
- Avoid severe impacts or rough handling that leads to damaging the ISA830/ISA830TG.
- Do not discharge static electricity onto the ISA830/ISA830TG.

- Use only mating connectors, not bare wires, for the terminals.
- Do not block or obstruct the cooling fan vent opening.
- Do not perform measurement at a power generating source or building installation site (Note below).
- Do not disassemble the ISA830/ISA830TG unless you are technically qualified.

(Note) EN 61010-1:2001 specifies the measurement categories and their requirements as follows. The ISA830/ISA830TG falls under category II.

- Measurement category IV is for measurement performed at the source of low-voltage installation.
- Measurement category III is for measurement performed in the building installation.
- Measurement category II is for measurement performed on the circuits directly connected to the low voltage installation.

Power Supply



WARNING

- AC Input voltage: 100 to 240 V AC, 50/60Hz, 90W maximum
- DC Input voltage: 12V DC, 40W maximum
- The power supply voltage should not fluctuate more than 10%.
- Connect the protective grounding conductor of the AC power cord to an earth ground, to avoid electrical shock.

Fuse



WARNING

- Fuse type: T1.6A/ 250V, time-delay, 5x20mm glass
- To ensure fire protection, replace the fuse only with the specified type and rating.
- Disconnect the power cord before fuse replacement.
- Make sure the cause of fuse blowout is fixed before fuse replacement.

Cleaning the ISA830/ISA830TG

- Disconnect the power cord before cleaning.
- Use a soft cloth dampened in a solution of mild detergent and water. Do not spray any liquid into the ISA830/ISA830TG.
- Do not use chemicals or cleaners containing harsh products such as benzene, toluene, xylene, and acetone.

Operation Environment

- Location: indoor, no direct sunlight, dust free, almost non-conductive pollution (Note below)
- Relative Humidity: < 90%
- Altitude: < 2000m
- Temperature: 18 to 28°C

Storage Environment

- Location: indoor
- Relative humidity: < 85%
- Temperature: 0 to 40°C

(Note) EN 61010-1:2001 specifies the pollution degrees and their requirements as follows. The ISA830/ISA830TG falls under degree 2.

Pollution refers to “addition of foreign matter, solid, liquid, or gaseous (ionized gases), that may produce a reduction of dielectric strength or surface resistivity”.

- Pollution degree 1: No pollution or only dry, non-conductive pollution occurs. The pollution has no influence.
 - Pollution degree 2: Normally only non-conductive pollution occurs. Occasionally, however, a temporary conductivity caused by condensation must be expected.
 - Pollution degree 3: Conductive pollution occurs, or dry, non-conductive pollution occurs which becomes conductive due to condensation which is expected. In such conditions, equipment is normally protected against exposure to direct sunlight, precipitation, and full wind pressure, but neither temperature nor humidity is controlled.
-

Power cord for the United Kingdom

When using the ISA830/ISA830TG in the United Kingdom, make sure the power cord meets the following safety instructions.

NOTE: This lead / appliance must only be wired by competent persons



WARNING: THIS APPLIANCE MUST BE EARTHED

IMPORTANT: The wires in this lead are coloured in accordance with the following code:

Green/ Yellow:	Earth	
Blue:	Neutral	
Brown:	Live (Phase)	

As the colours of the wires in mains leads may not correspond with the colour markings identified in your plug/appliance, proceed as follows:

The wire which is coloured Green & Yellow must be connected to the Earth terminal marked with the letter E or by the earth symbol or coloured Green or Green & Yellow.

The wire which is coloured Blue must be connected to the terminal which is marked with the letter N or coloured Blue or Black.

The wire which is coloured Brown must be connected to the terminal marked with the letter L or P or coloured Brown or Red.

If in doubt, consult the instructions provided with the equipment or contact the supplier.

This cable/appliance should be protected by a suitably rated and approved HBC mains fuse: refer to the rating information on the equipment and/or user instructions for details. As a guide, cable of 0.75mm² should be protected by a 3A or 5A fuse. Larger conductors would normally require 13A types, depending on the connection method used.

Any moulded mains connector that requires removal /replacement must be destroyed by removal of any fuse & fuse carrier and disposed of immediately, as a plug with bared wires is hazardous if a engaged in live socket. Any re-wiring must be carried out in accordance with the information detailed on this label.

GETTING STARTED

This chapter describes the ISA830/ISA830TG in a nutshell, including its main features, package contents, and front / rear / display panel introduction. After going through the overview, follow the Power-up sequence and Functionality check section to properly setup the ISA830/ISA830TG.



ISA830/ISA830TG package	ISA830/ISA830TG Characteristics	12
	Package Contents	13
Panel introduction	Front Panel Overview	14
	Rear Panel Overview	18
	Display Overview	21
	Status Icon overview	22
Setup	Tilt stand	24
	Power Up	24
	Error Check	26
	Functionality Check	27

ISA830/ISA830TG Characteristics

The ISA830/ISA830TG is a mid-to-high range digital storage spectrum analyzer suitable for a wide variety of applications, such as production testing, research, and field verification.

Performance	<ul style="list-style-type: none"> ● Low noise floor: typical -117dBm @1GHz, 3k RBW ● Fast sweep: 50ms to 25.6s ● Compact size: 330(W) x 170(H) x 340(D) mm ● Light weight: approx. 6kg
Features	<ul style="list-style-type: none"> ● Autoset ● 5 markers with delta marker and peak functions ● 3 traces ● Power measurements: ACPR, OCBW, N-dB, Phase Jitter ● Pass/fail test with limit line editing ● Split windows with separate settings ● Sequence programming (user-defined macro) ● 6.4" TFT color LCD, 640 x 480 resolution
Interface	<ul style="list-style-type: none"> ● USB host for storage device connection ● USB slave/RS232/GPIB(not supported) for PC software connection and remote control ● Direct VGA display image output ● Reference signal input/output for synchronization ● External trigger signal input
Optional Items	<ul style="list-style-type: none"> ● Tracking Generator

Package Contents

Contact your dealer in case of missing items. The detailed specifications are listed from page223.

ISA830/ISA830TG

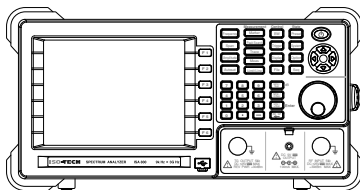

Standard accessories

- Power cord
- USB cable (Type A to Type B) for PC connection
- User Manual (this document)

Optional items

Option01 Tracking Generator (factory installed, ISA830TG only)

Front Panel Overview

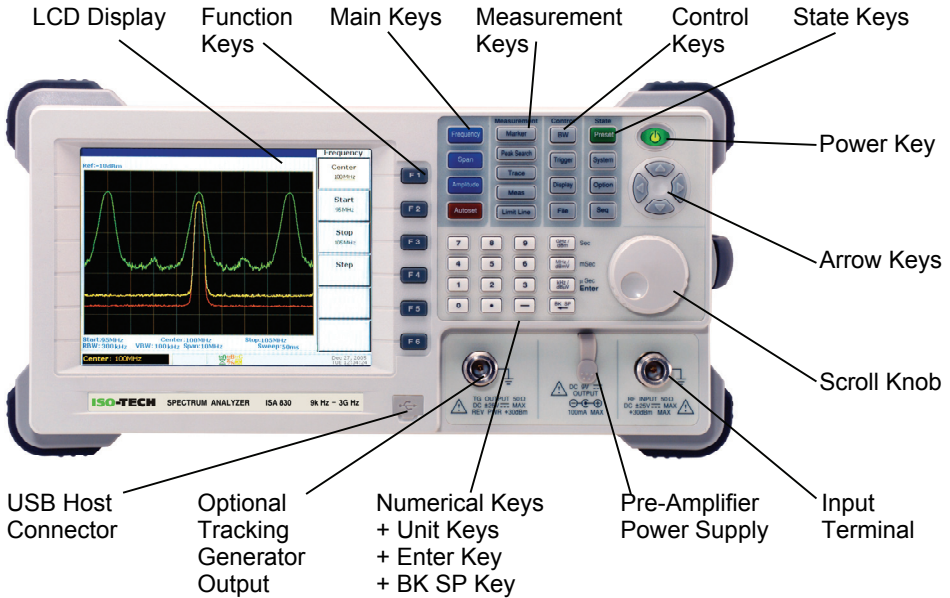

LCD Display

TFT Color display, 640x480 resolution. For display setting details, see page 142.

F1 to F6 Function Keys



Soft keys linked to the menu that appears on the right side of the display.

Main Keys

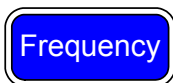

Frequency key (page51), together with **Span key**, configures the horizontal (frequency) scale.

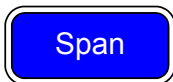

Amplitude key (page60) configures the vertical (amplitude) scale and input impedance.



Autoset key (page75) automatically searches the peak signal with maximum amplitude and displays it with appropriate horizontal and vertical scales.



Measurement keys



Marker key (page81) activates markers and places them on specified locations.



Peak Search key (page91) searches peak signals and configures peak ranges/orders.

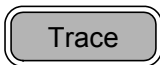

Trace key (page100) activates trace signals, configures them, and runs trace math operations.

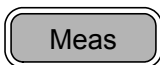

Measurement key (page112) configures and runs 4 types of Power Measurements: ACPR, OCBW, N-dB, and Phase Jitter.



Limit Line key (page122) configures high/low limit lines and runs the pass/fail test.

Control keys



BW key (page129) configures the RBW/VBW width, sweep time length, and waveform averaging number.



Trigger key (page137) selects the trigger type, sets the trigger running mode / delay / frequency, and activates the external trigger input.



Display key (page142) configures the LCD dimmer, edits and shows the display line and title, and activates split windows.



File key (page150) saves/recalls/deletes the trace waveform, limit line, amplitude correction, sequence, and panel settings. Display images may be saved to a storage device via the front panel USB port.

State Keys



Preset key (page50or164) resets the ISA830/ISA830TG to a predefined state.

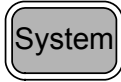

System key configures the date/time (page175), RS232C interface (page168), and language (page178). It also shows the system information (page169) and self test result (page174), and saves/recalls panel settings (page166).



Option key configures the Tracking Generator (ISA830TG only) (page188). Other options are not supported.



Seq key (page180) edits and runs sequences (user-defined macro).

Power Key



Power key selects the power state between the standby mode (Red LED on) and power on mode (Green LED on). To turn on/off the main power, use the power switch on the rear panel. See page24 for the power up sequence.

Arrow Keys

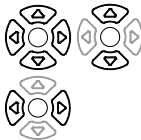

Arrow keys select parameters in various occasions; Up/Right for increasing, Down/Left for decreasing.

Scroll Knob



Scroll knob sets or selects parameters in various occasions. In many cases, it works in tandem with the Arrow keys.

Input Terminal

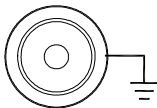

Input terminal accepts RF input signals.

- Maximum +30dBm
- Input impedance 50Ω

RF INPUT 50 Ω
DC ±25V MAX
+30dBm MAX



Pre-Amplifier Power Supply Terminal



Pre-amplifier power supply terminal is not supported.



DC 9V MAX
OUTPUT



100mA MAX.

Numerical Keys Numerical keys set various parameters. In many cases, they work in tandem with the Arrow keys and Scroll knob.
Unit Keys

Enter Key
BK SP key

Example **Key sequence**

9kHz



-3.8dB



1.0mS



9 + Enter



Correction



Optional TG Output Terminal

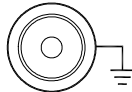

Outputs the optional Tracking Generator (ISA830TG) signal. Reversed power should not exceed +30dBm. For details, see page188.

⚠ TG OUTPUT 50 Ω
 DC ±25V --- MAX

USB Host Connector

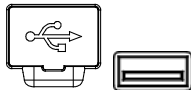

Via the USB port (typeA male), display images may be saved to or recalled from USB flash drives For details, see page150.

Rear Panel Overview

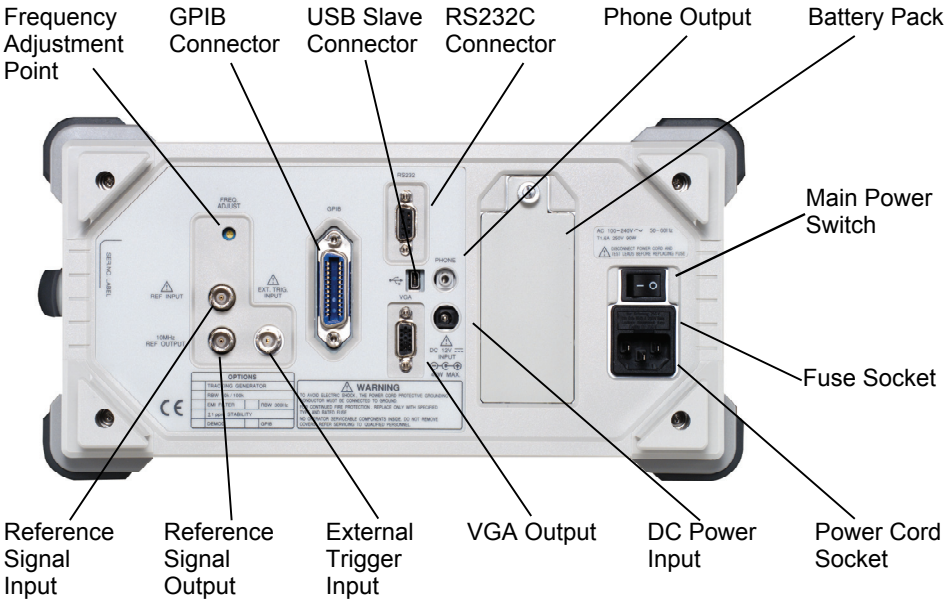

Frequency Adjustment Point

FREQ. ADJUST

Adjusts the internal reference signal frequency; for service operation only.



GPIB Connector

Not supported.

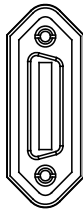

USB Connector

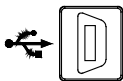

Type B mini connector for PC software connection (page192) and remote control (page201). For interface setting details, see page168.

**RS232C
Connector**

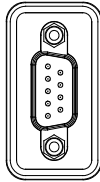

9 pin female connector for PC software connection (page192) and remote control (page201). For interface setting details, see page168.

Battery Pack

Not supported.

Phone Output

PHONE

Not supported.

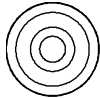

**Main Power
Switch,
Fuse Socket,
Power Cord
Socket**

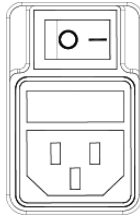

The main power switch turns on/off the ISA830/ISA830TG main power. For the power up sequence, see page24.
The fuse socket stores the main fuse, T1.6A 250V, time-delay, 5x20mm glass.
The power cord socket accepts the AC power cord, 100 to 240V, 50/60Hz.
For power and fuse related safety instructions, see page7.

DC Power Input



⚠
DC 12V ---
INPUT
⊖ ⊕
40W MAX.

DC power input, 12V, 40W max rating. Accepts a standard 2.1mm DC plug.

VGA Output

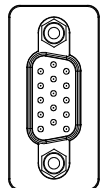

15pin, female VGA connector which outputs 640 x 480 resolution display image to an external monitor. For details, see page147.

External Trigger Input

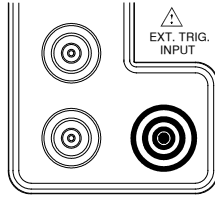

Accepts a trigger signal from an external device. For details, see page137.

Reference Output

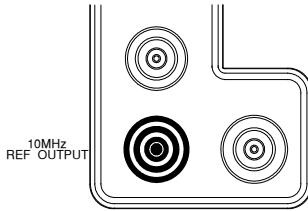

Outputs +5V TTL, 10MHz reference signal used for synchronizing the ISA830/ISA830TG with an external device. For details, see page176.

Reference Input

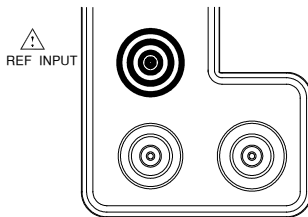

Accepts a TTL signal from an external device, used for synchronization with the ISA830/ISA830TG For details, see page177.



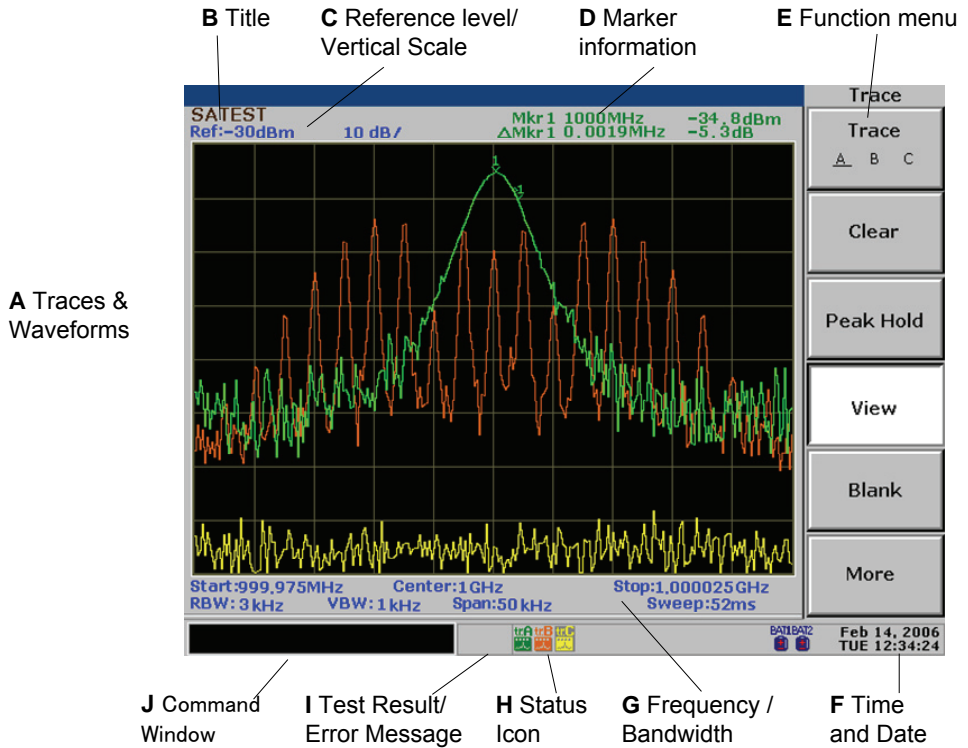











Display Overview



A	Traces & Waveforms	Input signals and traces that appear within the main display area. Input signal & TraceA: Green, TraceB: Red, TraceC: Yellow. For trace details, see page100.
B	Title	The title of the current display. For details, see page144.
C	Reference Level/Scale	The reference amplitude level and vertical scale. For amplitude details, see page60.
D	Marker Information	The frequency and amplitude for the active marker / delta marker. For marker details, see page81.
E	Function Menu	The menu associated with F1 to F6 function keys on the right side of the display.
F	Date and Time	Current date and time. For setup details, see page175.

G	Frequency/ Bandwidth	Upper line: shows the start/stop frequency (page55) and center frequency (page52). Lower line: shows the VBW (video bandwidth - page131), RBW (resolution bandwidth - page130), frequency span (page52), and sweep time (page134).
H	Status Icon	The icons showing various system conditions. See the below Status Icon overview for details.
I	Test Result/ Error Message	The result of the pass/fail test using limit lines (page127) or the system error messages (page169).
J	Command Window	Shows the current status of the selected menu or the entered parameters such as frequency and amplitude.

Status Icon overview

Amplitude (page60)		External gain on, amplitude correction on, Input impedance 75Ω, Input impedance calibration on
Peak Search (page91)		Peak track on
Trace (page100)	 TraceA:green,  B:red,  C:yellow	
		Clear mode
		Average on
		Peak hold mode
		View mode, trace math
BW (page129)		RBW, VBW manual mode
		Sweep time manual mode
Trigger (page137)		Video trigger mode
		External trigger signal on
Options		TG normalization activated (page188)
Sequence(page180)		Sequence currently running

USB



USB flash drive is detected (page151), or USB remote control connection is detected (page203)

Tilt Stand & Power Up

Tilt stand

Low angle

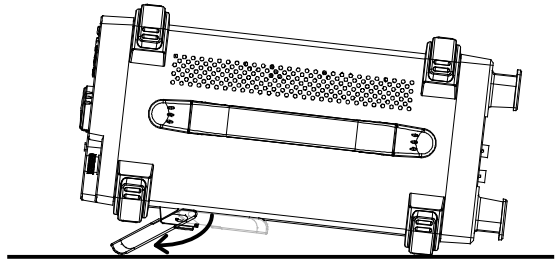
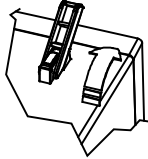
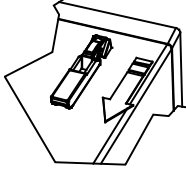

High angle

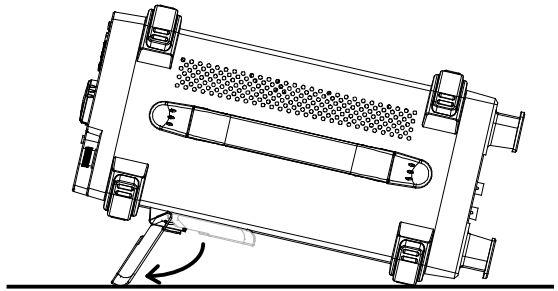
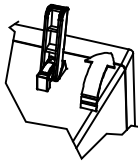
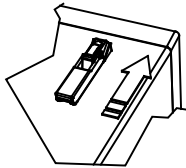

Power Up

1. Connect the power cord to the rear panel socket.

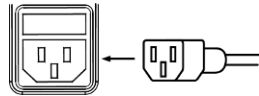

2. Turn on the main power switch.



3. The ON/STBY key on the front panel turns red.



4. Press the ON/STBY key. Its color turns green and the display becomes active.



Last Stored Settings

At the initial state, only the F3 menu “Last stored state” becomes available. For details of storing the panel settings, see page166.



To recall the last stored panel settings:

Press F3. One of the panel settings from S1 – S10, which was stored the last time, will be recalled.

To use the ISA830/ISA830TG without recalling the last stored panel settings:

Press any other function keys (see below).

List of function keys

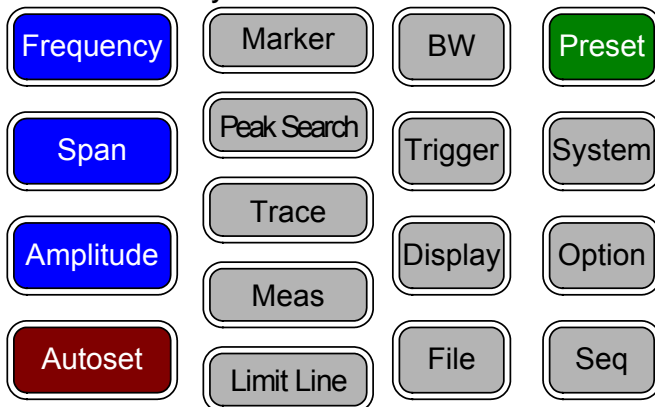

Note

Ignore the error message that might appear at the bottom of the display when powering up the ISA830/ISA830TG. The message indicates that internal configurations are ongoing. For error message details, see page26.

Error Check

This section assumes that the ISA830/ISA830TG is already powered up (page24).

- 1. Check system error** Check for error messages at the bottom of the display, next to the command window.



Contact the service center if any of the following messages remains in the display.



- Inappropriate RBW or VBW is selected.
- Frequency is less than 15MHz and amplitude is less than -30dBm.



External reference input is not working properly.



Local oscillator 1 is not working properly.



Local oscillator 3 is not working properly.



Internal reference signal is not working properly.

2. Check self test result

View the ISA830/ISA830TG's self-diagnosis test result. Press the System key → F6 (More) → F2 (Self Test).



The test automatically runs at each power-up. The underline shows the result, pass or fail. Contact the service center if any of the items fails.

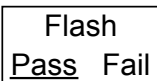

Internal Flash memory for storing the system code/data

SDRAM <u>Pass</u> Fail	F 3	Internal SDRAM for running the system code
---------------------------	------------	--

RTC <u>Pass</u> Fail	F 4	Internal real time clock for configuring the date and time
-------------------------	------------	--

Functionality Check

- This section assumes that the ISA830/ISA830TG is already powered up (page24).
- Before operating the ISA830/ISA830TG in a new environment, run these steps to make sure it is functionally stable.

1. Feed a signal

Input a signal to check if the ISA830/ISA830TG correctly shows the waveform on the display. There are two ways to feed an input signal.

Feeding the DUT signal

If the DUT is already available, connect the output signal to the RF input terminal. The signal amplitude must be less than +30dBm.

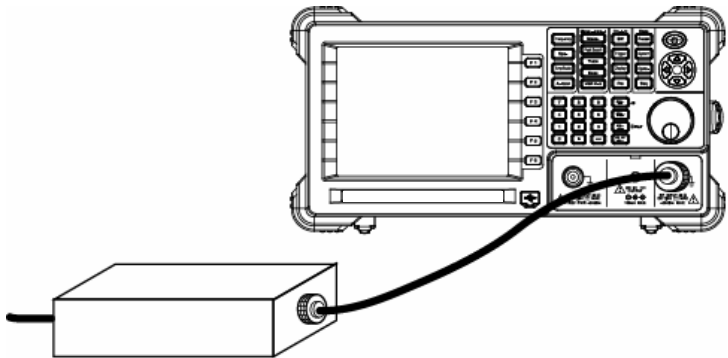

Feeding the internal auxiliary signal

You can also use the internal auxiliary signal, 100MHz/-30dBm. No cable connection is required in this case. Activate the signal by pressing the System key→F4 (Aux Sig On).



System	→	Aux Sig <u>On</u> Off	F 4
--------	---	--------------------------	------------

2. View the signal

Press the Autoset key→F1 (Autoset).



The ISA830/ISA830TG automatically configures the horizontal and vertical scales and shows the signal on the display.

Check the peak frequency and amplitude that appear on the top right corner of the display. To move the marker, use the Scroll knob  or Left/Right keys .

Internal auxiliary signal, -30dBm @100MHz
 Peak frequency/amplitude

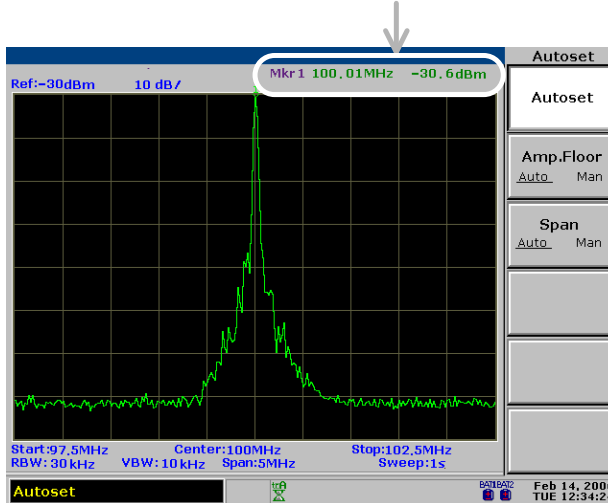

If the displayed value does not match the actual signal, contact the service center.

QUICK REFERENCE

Shortcuts	Power-on screen.....	30
	Frequency and Span	30
	Amplitude	30
	Autoset	30
	Marker	31
	Peak Search.....	31
	Trace	31
	Power Measurement	32
	Limit Line	32
	Bandwidth	32
	Trigger	33
	Display.....	33
	File	33
	System.....	34
	Option.....	34
Sequence	34	
Menu Tree	Power-on screen.....	36
	Frequency, Span, Autoset, Amplitude(1 of 2).....	36
	Amplitude (2 of 2), Marker.....	37
	Peak Search, Trace	39
	Measurement, Limit Line	41
	BW, Trigger, Display	43
	File (1 of 2)	44
	System.....	47
Option, Sequence	48	
Preset	Preset Contents.....	50

Operation Shortcuts

Here is the list of available operations and their shortcuts.

Power-on screen

Recall the last stored settings	F3
---------------------------------	----

Frequency and Span

Set Center Frequency and Span	Frequency→F1→Span→F1
Set Start and Stop Frequency	Frequency→F2(Start), F3(Stop)
Set Frequency Step	Frequency→F4
Activate Full Span (3.0GHz)	Span→F2
Activate Zero Span (Time Domain)	Span→F3
Recall Last Span	Span→F4

Amplitude

Set Reference Level	Amplitude→F1
Select Vertical Scale	Amplitude→F2
Select Unit (dBm/dBmV/dBuV)	Amplitude→F3→F1 to F3
Set External Gain	Amplitude→F4
Activate Amplitude Correction	Amplitude→F5→F2
Select Amplitude Correction Set	Amplitude→F5→F1→F1
Delete Amplitude Correction Item	Amplitude→F5→F1→F2
Delete Amplitude Correction Set	Amplitude→F5→F1→F3→F2
Undo Correction Item/Set Deletion	Amplitude→F5→F1→F4
Save Amplitude Correction Set	Amplitude→F5→F1→F5
Select Input Impedance (50Ω/75Ω)	Amplitude→F6→F1
Set Input Impedance Offset	Amplitude→F6→F2

Autoset

Run Autoset	Autoset→F1
Set Amplitude Floor	Autoset→F2
Set Frequency View Span	Autoset→F3

Marker

Activate Normal Marker	Marker→F1→F2
Activate Delta Marker	Marker→F1→F2→F3
Activate All Normal Markers	Marker→F6→F3
Move Marker to Peak	Marker→F4 or Peak Search
Move Marker and Peak to Center	Marker→F4→F5 or Peak Search→F5
Track Marker on Peak	Peak Search→F6→F4
Move Marker to Various Locations	Marker→F6→F4→F1 to F5
Show Marker Table	Marker→F6→F2
Put Marker on Trace	Marker→F6→F1

Peak Search

Search Peak Signal	Peak Search or Marker→F4
Search Next Peak	Peak Search→F2
Search Next Peak to Right	Peak Search→F3
Search Next Peak to Left	Peak Search→F4
Search Peak and Move to Center	Peak Search→F5 or Marker→F4→F5
Track Marker on Peak	Peak Search→F6→F4
Search Minimum Amplitude	Peak Search→F6→F5
Show Peak Table	Peak Search→F6→F1
Sort Peaks in Peak Table	Peak Search→F6→F2
Set Peak Threshold	Peak Search→F6→F3

Trace

Activate Trace	Trace→F1
Clear Trace (Update in Real-Time)	Trace→F2
View Peak Hold Trace	Trace→F3
Freeze Trace	Trace→F4
Hide Trace	Trace→F5
View Averaged Trace	Trace→F6→F1 or BW→F4
Run Trace Math	Trace→F6→F2→F1 to F5
Select Signal Detection Mode	Trace→F6→F3→F1 to F5

Power Measurement

Activate ACPR	Meas→F2
Set ACPR Channel Bandwidth	Meas→F1→F1
Set ACPR Channel Space	Meas→F1→F2
Set ACPR Adjacent Channel Offset	Meas→F1→F4→F2 and F4
Set ACPR Adjacent Channel BW	Meas→F1→F4→F1 and F3
Move ACPR Channel Up	Meas→F4
Move ACPR Channel Down	Meas→F5
Activate OCBW	Meas→F3
Set OCBW Channel Bandwidth	Meas→F1→F1
Set OCBW Channel Space	Meas→F1→F2
Set OCBW %	Meas→F1→F3
Move OCBW Channel Up	Meas→F4
Move OCBW Channel Down	Meas→F5
Activate N dB	Meas→F6→F1
Set N dB Value	Meas→F6→F2
Activate Phase Jitter	Meas→F6→F3
Set Phase Jitter Offset	Meas→F6→F4→F1(Start), F2(Stop)

Limit Line

Activate Limit Line	Limit Line→F1 (High), F2 (Low)
Select Limit Line for Edit	Limit Line→F3→F1
Activate Limit Line Edit Table	Limit Line→F3→F2
Delete Limit Line Table Item	Limit Line→F3→F3
Delete All Table Item	Limit Line→F3→F4→F2
Undo Last Deletion	Limit Line→F3→F5
Run Pass/Fail Test	Limit Line→F4
Select Pass/Fail Condition	Limit Line→F5

Bandwidth

Select RBW	BW→F1
Select VBW	BW→F2
Set Sweep Time	BW→F3
Set Trace Average Number	BW→F4 or Trace→F6→F1
Reset RBW/VBW/Sweep to Auto	BW→F5

Trigger

Select Free Run (Default)	Trigger→F1
Select Video/External Trigger	Trigger→F2
Select Trigger Mode	Trigger→F3
Set Trigger Delay	Trigger→F4
Set Trigger Frequency	Trigger→F5
Run Trigger (in Single/Continuous)	Trigger→F6

Display

Change Dimmer Level	Display→F1
Show Display Line	Display→F2
Clear Title	Display→F3→F1
Enter Title	Display→F3→F2 to F4
Show Title	Display→F3→F5
Activate Split Window	Display→F4→F1 (Upper), F2 (Lower)
Alternate Upper/Lower Sweep	Display→F4→F3
Switch Split Display to Full Screen	Display→F4→F4

File

Select Copy Source File	File→F1→F1→F1 to F5
Select Copy Destination File	F2→F1 to F5 (After Selecting Source)
Edit Copied File Name	F3 (After Selecting Destination)
Copy Selected File	F4 (After Selecting Source/Destination)
Select File for Deletion	File→F2→F1→F1 to F5
Delete Selected File	F2 (After Selecting File)
Rename File	File→F3→F1
Confirm New File Name	F2 (After Renaming File)
Save Display Image to USB Drive	File→F4→F1→F2
Rename File in USB Drive	File→F4→F1→F1
Select System Code for Update	File→F5→F1→F1
Select Language for Update	File→F5→F1→F2
Update System File from USB Drive	F2 (After Selecting File)

Preset

Recall Factory Installed Settings	Preset
-----------------------------------	--------

System

Save Setup	System→F1→F1 or F2→F3
Recall Setup	System→F1→F1 or F2→F4
Select GPIB Address	System→F2 (Not supported)
Show RS-232C Configuration	System→F3→F1 to F4
Activate Auxiliary Signal	System→F4
Set Date	System→F6→F1→F1→F1 to F4
Set Time	System→F6→F1→F2→F1 to F3
Activate Clock Display	System→F6→F1→F3
View Self Test Result	System→F6→F2
View System Configuration	System→F6→F4
Select Language	System→F6→F5→F1

Option

Activate Tracking Generator	Option→F1→F1
Set Tracking Generator Amplitude	Option→F1→F2
Normalize Tracking Generator	Option→F1→F3→F2
Activate Normalized TG	Option→F1→F4
Set Ref Level for TG Normalization	Option→F1→F5
Activate FM Demodulator	Option→F2→F1 (Not supported)
Activate AM Demodulator	Option→F2→F2 (Not supported)
Activate Phone Output	Option→F2→F3 (Not supported)
Set Phone Output Volume	Option→F2→F4 (Not supported)
Set Squelch Level	Option→F2→F5 (Not supported)
View Battery Level (Not supported)	Option→F3 (Not supported)
Set Ext. Reference Signal Frequency	Option→F4

Sequence

Select Sequence Set	Sequence→F1, F2
Start Sequence Edit	Sequence→F3→F1
Insert 100ms Delay	Sequence→F3→F2
Insert Pause in Sequence	Sequence→F3→F3

Insert Another Sequence Set	Sequence→F3→F4→F1 to F2
Stop Sequence Edit	Sequence→F3→F5
Insert Item to Sequence Set	Sequence→F3→F6→F1
Save Sequence Set	Sequence→F3→F6→F2
Delete Sequence Item	Sequence→F3→F6→F3
Delete Sequence Set	Sequence→F3→F6→F4→F2
Undo Sequence Item/Set Delete	Sequence→F3→F6→F5
Select Sequence Run Mode	Sequence→F4→F1
Run Sequence	Sequence→F4→F2
Delete All Sequence Set	Sequence→F5→F2

Menu Tree

Power-on screen

Last stored state	F 3
-------------------	-----

Frequency, Span, Autoset, Amplitude(1 of 2)

Frequency	Span	Autoset
Center 1.5 GHz F 1	Span 3 GHz F 1	Autoset F 1
Start 0 kHz F 2	Full Span F 2	Amp.Floor Auto Man F 2
Stop 3 GHz F 3	Zero Span F 3	Span Auto Man F 3
Step 1 MHz F 4	Last Span F 4	

Amplitude	
Ref.Level 0 dBm F 1	dBm F 1
Scale dB/Div 10 5 2 1 F 2	
Units... F 3	
Ext.Gain 0dB F 4	dBmV F 2
Corrections.. F 5	dBuV F 3
More F 6	Return F 6

Amplitude (2 of 2), Marker

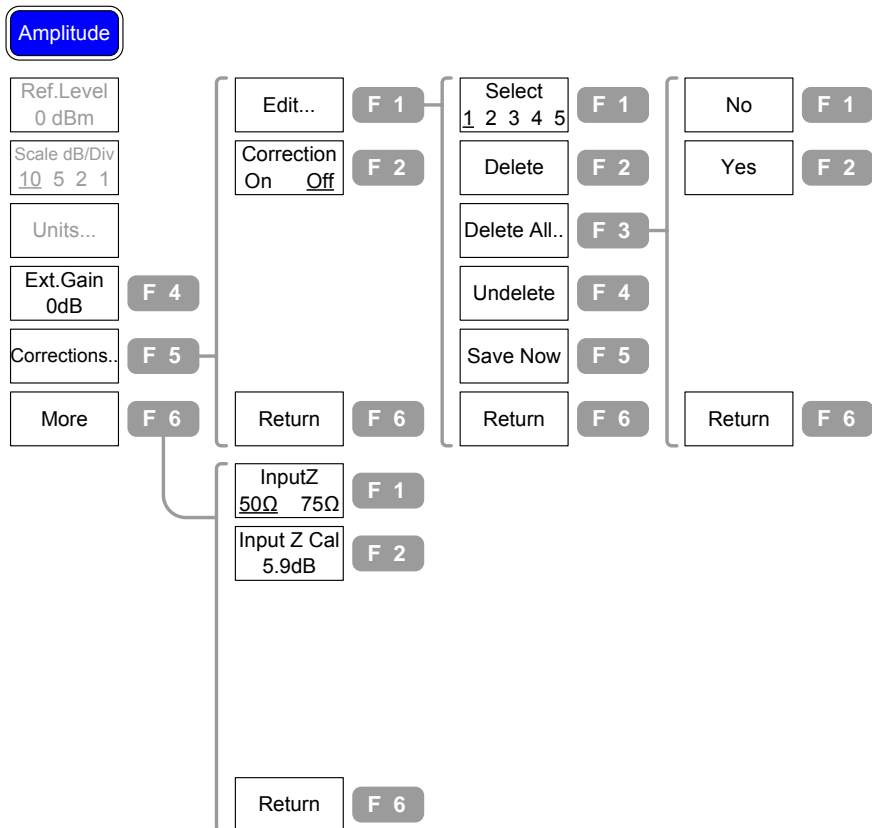

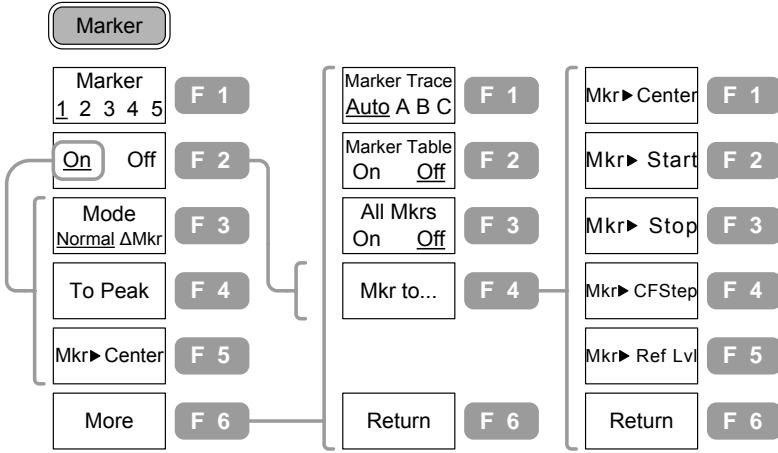

Peak Search, Trace

Peak Search

Pk Search F 1

Next Peak F 2

Next Pk
Right F 3

Next Pk
Left F 4

Mkr▶Center F 5

More F 6

Peak Table F 1
On Off

Peak Sort F 2
Freq Amp

Pk Threshold F 3
On Off

Track F 4
On Off

Min Search F 5

Return F 6

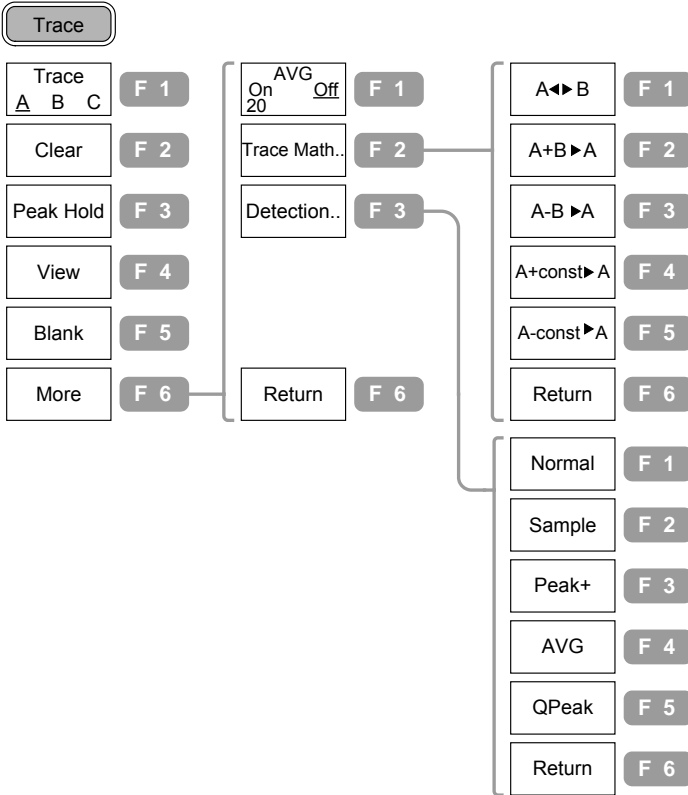

Measurement, Limit Line

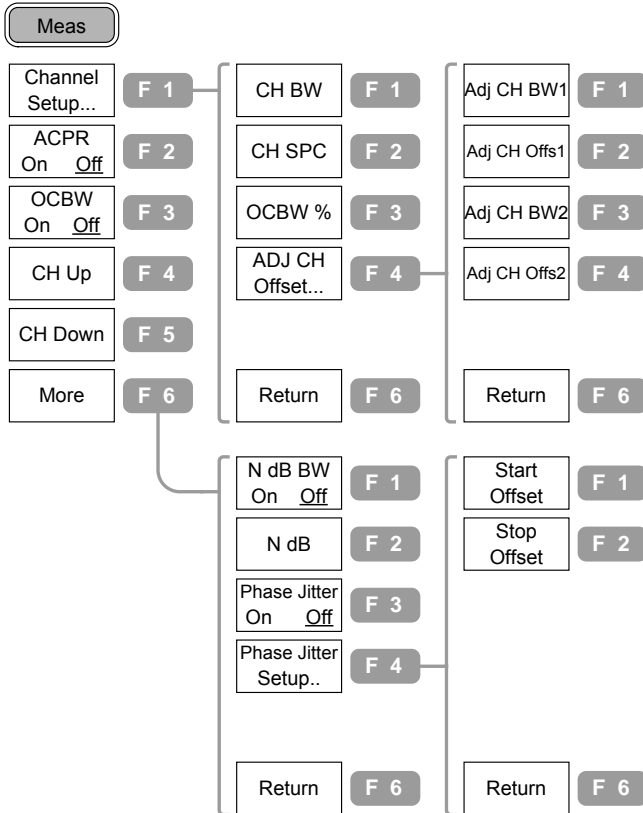

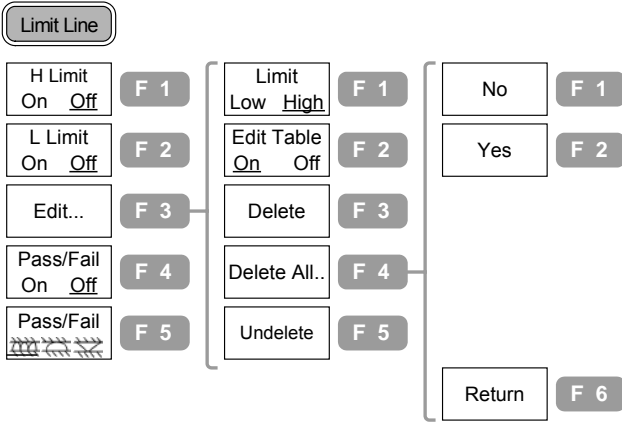

BW, Trigger, Display

BW

RBW Auto Man	F 1
VBW Auto Man	F 2
Swp Tm Auto Man	F 3
AVG On 20 Off	F 4
All Auto	F 5

Trigger

Free Run	F 1
Trigger Condition Video Ext.	F 2
Trigger Mode Nor. Sgl. Cont.	F 3
Trigger Delay 50ms	F 4
Trigger Freq 1.5GHz	F 5
Run Now	F 6

Display

LCD Dimmer	F 1	<table border="1"> <tr> <td>Clear Title</td> <td>F 1</td> </tr> <tr> <td>(Capital Letter)</td> <td>F 2</td> </tr> <tr> <td>(Small Letter)</td> <td>F 3</td> </tr> <tr> <td>(Symbol)</td> <td>F 4</td> </tr> <tr> <td>Show Title</td> <td>F 5</td> </tr> <tr> <td>Return</td> <td>F 6</td> </tr> </table>	Clear Title	F 1	(Capital Letter)	F 2	(Small Letter)	F 3	(Symbol)	F 4	Show Title	F 5	Return	F 6	<table border="1"> <tr> <td>Upper</td> <td>F 1</td> </tr> <tr> <td>Lower</td> <td>F 2</td> </tr> <tr> <td>Alternate Sweep</td> <td>F 3</td> </tr> <tr> <td>Full Screen</td> <td>F 4</td> </tr> <tr> <td>Return</td> <td>F 6</td> </tr> </table>	Upper	F 1	Lower	F 2	Alternate Sweep	F 3	Full Screen	F 4	Return	F 6
Clear Title	F 1																								
(Capital Letter)	F 2																								
(Small Letter)	F 3																								
(Symbol)	F 4																								
Show Title	F 5																								
Return	F 6																								
Upper	F 1																								
Lower	F 2																								
Alternate Sweep	F 3																								
Full Screen	F 4																								
Return	F 6																								
Display Line On Off	F 2																								
Title...	F 3																								
Split Window...	F 4																								

File (1 of 2)

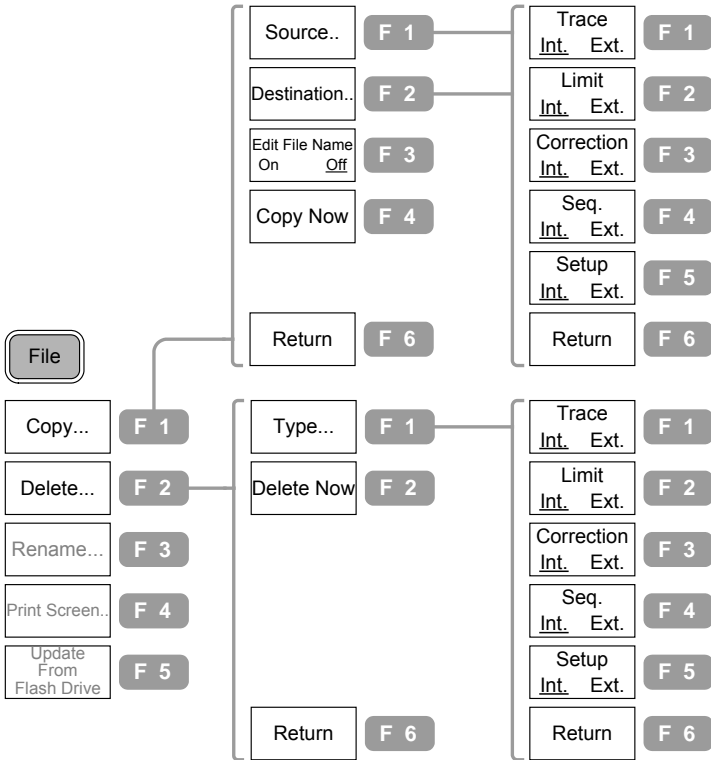

File (2 of 2)

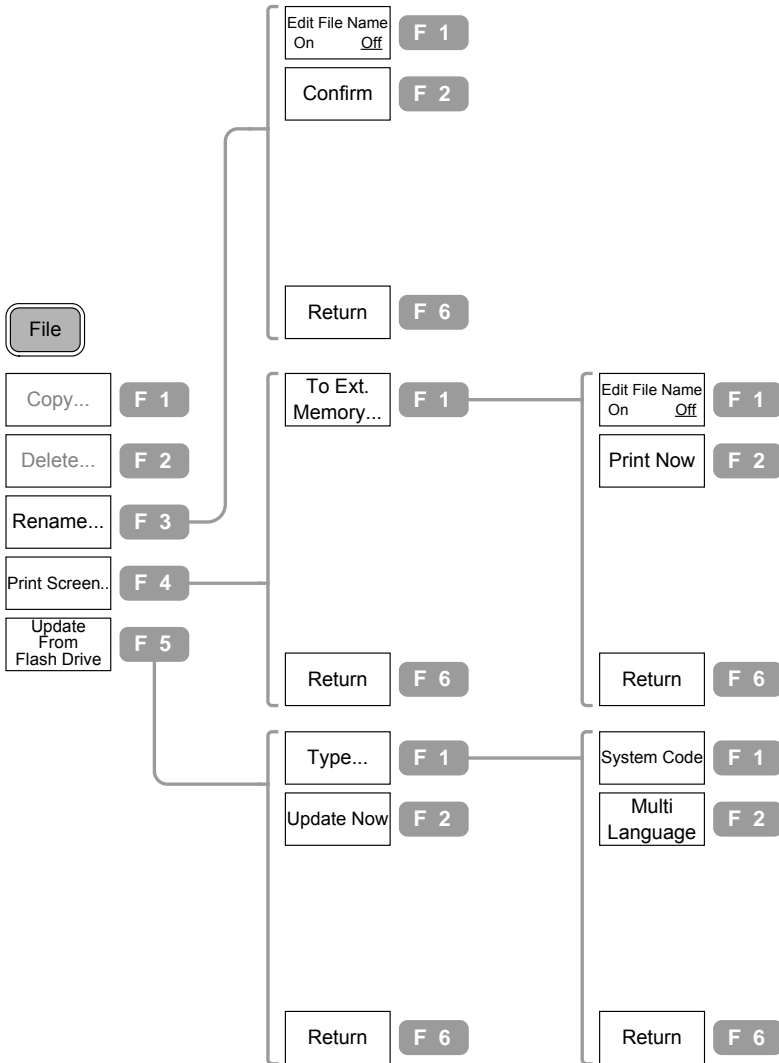

Preset



(No menu item)

System

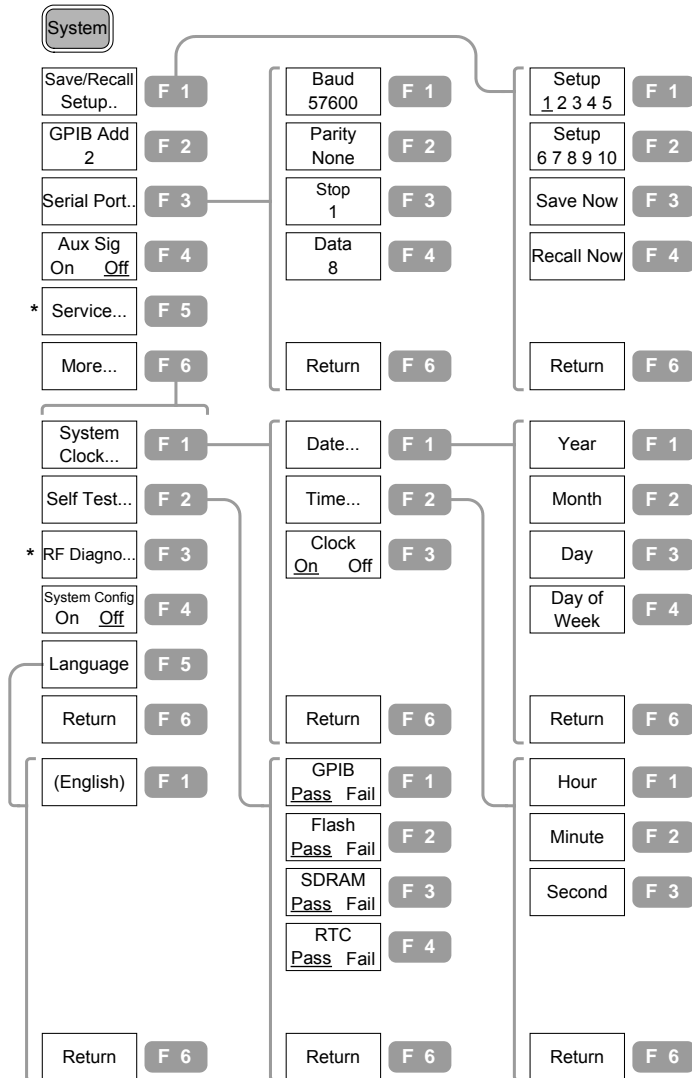

* Submenu only for service personnel

Option, Sequence

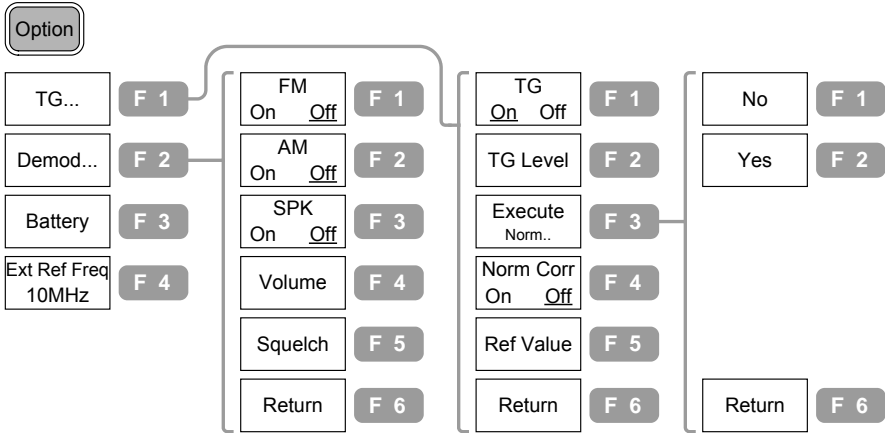

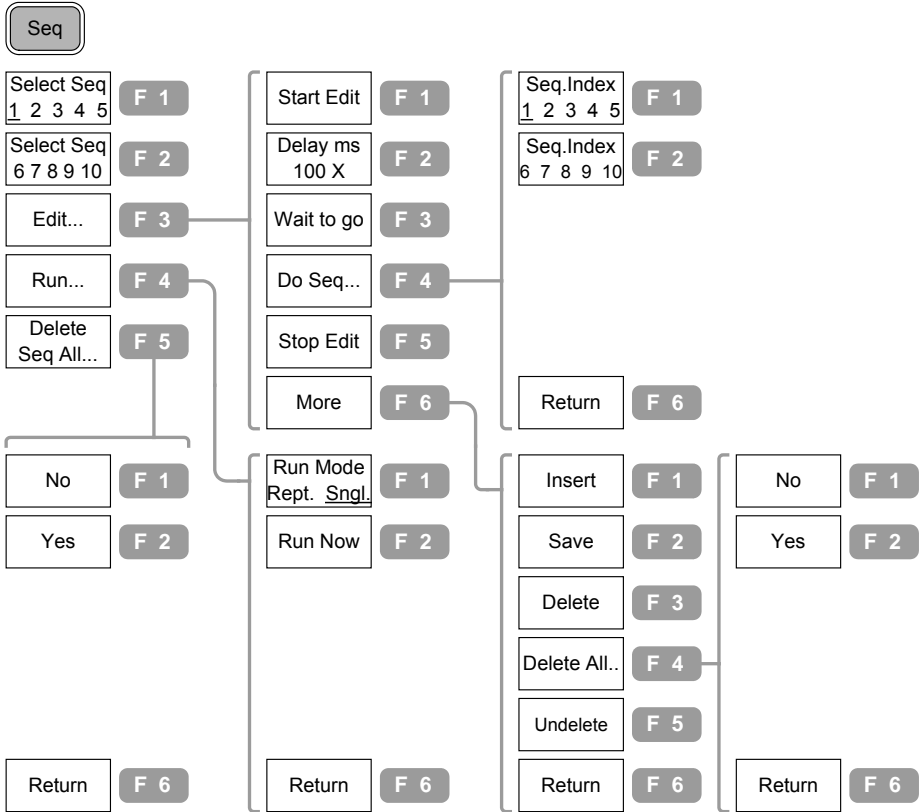

Preset Contents

These are the settings that appear when pressing the Preset key .

Frequency	Center: 1.5GHz Start: 0Hz	Stop: 3GHz Step: 1MHz
Span	3GHz	
Amplitude	Ref.level: 0dBm Unit: dBm Scale: 10dB/	External Gain: 0dB Input Z: 50Ω
Autoset	Amplitude Floor: Auto	Span: Auto
Marker	Marker: Off Marker Table: Off	Marker Trace: Auto All Marker: Off
Peak Search	Peak Table: Off Peak Threshold: Off	Peak Sort: Freq Peak Track: Off
Trace	Trace: A Average: Off, 20	Mode: Clear Detection: Normal
Meas	ACPR: Off CH SPC: 0 CH BW: 600MHz OCBW %: 0 N dB: Off	OCBW: Off Adj CH Offs: 0MHz Adj CH BWs: 0MHz Phase Jitter: Off
Limit Line	H & L Limit: Off	Pass/ Fail: Off
BW	RBW: Auto SwpTime: Auto	VBW: Auto Average: Off, 20
Trigger	Trigger Delay: 50ms Trigger Mode: Normal	Trigger Freq: 1.5GHz
Display	LCD Dimmer: 5 Split Window: Off	Display Line: Off Display Title: Off
File	Copy Type: Int. Trace Rename Type: Ext. Trace	Delete Type: Int. Trace
System	GPIB Add: 2 Aux Sig: Off	System Config: Off Clock: On
Option	External Ref Freq: 10MHz TG Norm Corr: Off	TG Output: Off TG Ref Value: 0dBm
Sequence	Sequence: 1	Run Mode: Single

FREQUENCY/SPAN

The **Frequency** key, together with **Span** key, sets the frequency scale. Two methods are available. Center-and-Span method defines the center point and surrounding frequency range. Start-and-Stop method defines the beginning and end of the frequency range. Special span settings are available at full and zero spans. The last span setting may also be recalled.

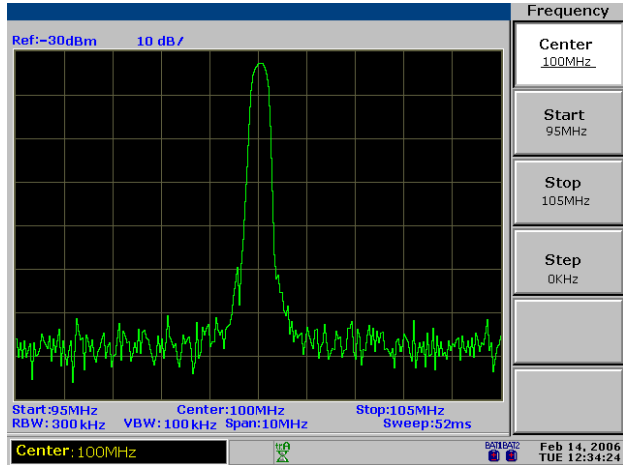



Center and Span	Set frequency adjustment step	52
	Set center frequency	52
	Set frequency span	53
Start and Stop	Set frequency adjustment Step	55
	Set start frequency	55
	Set stop frequency	56
Span	Display full frequency span (3GHz)	58
	Display zero span (time domain)	58
	Recall the Last Span Setting	59

View Signal (Center and Span)

Center-and-Span method defines the center frequency and the left/right bandwidth (span) to locate the signal.

Set frequency adjustment step

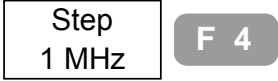
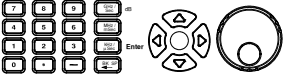
Background	Frequency adjustment step defines the Arrow keys resolution for center, start, and stop frequency.	
Panel operation	<ol style="list-style-type: none"> 1. Press the Frequency key. 2. Press F4 (Step). 3. Enter the value using the Numerical and Unit keys, Arrow keys, and Scroll knob. 	  
Range	0kHz to 3GHz * Arrow keys and Scroll knob resolution: 1/10 of Span	

Set center frequency

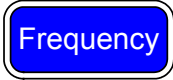
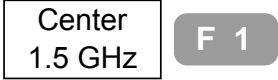
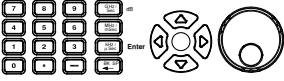
Panel operation	<ol style="list-style-type: none"> 1. Press the Frequency key. 2. Press F1 (Center). 3. Enter the value using the Numerical and Unit keys, Arrow keys, or Scroll knob. 	  
Range	0kHz to 3GHz Arrow keys and Scroll knob resolution: step value	
Note	Center frequency and span settings automatically change according to start and stop frequency settings, and vice versa.	

Display

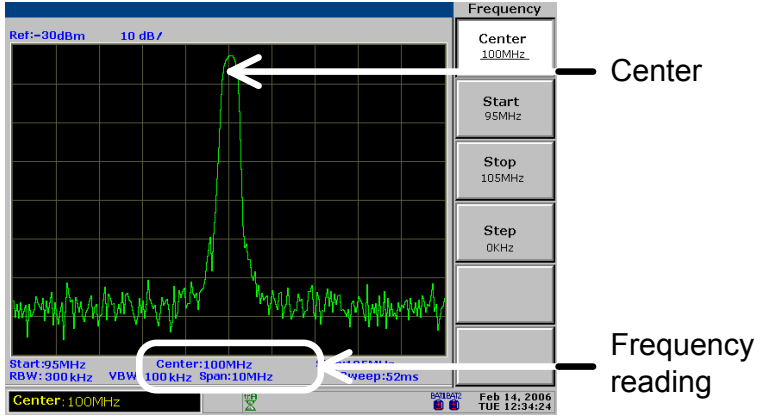

Set frequency span

Panel operation 1. Press the Span key.



2. Press F1 (Span).

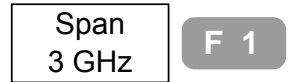

3. Enter the value using the Numerical and Unit keys, Arrow keys, and Scroll knob.

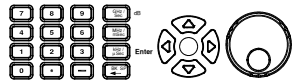

Range

2kHz to 3GHz

* Arrow keys & Scroll knob resolution: 1-2-5 sequence

(0 [zero span], 2kHz, 5kHz, 10kHz, 20kHz, 50kHz,1GHz, 2GHz, 3GHz)

Display

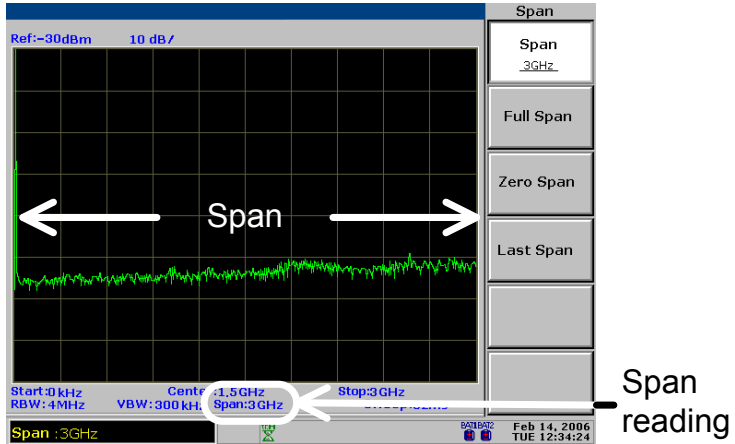

Note

- Center frequency and span settings automatically change according to start and stop frequency settings, and vice versa.
- If the span becomes smaller than the CHBW (channel bandwidth) in the ACPR or OCBW measurement (page 112), the warning “Span is less than CHBW!” appears in the command window.



View Signal (Start and Stop)

Start-and-Stop method defines the beginning (start) and the end (stop) of the frequency range.

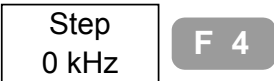
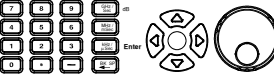
Set frequency adjustment Step

Background	Frequency adjustment step defines the Arrow keys resolution for Center, Start, and Stop frequency.	
Panel operation	<ol style="list-style-type: none"> 1. Press the Frequency key. 2. Press F4 (Step). 3. Enter the value using the Numerical and Unit keys, Arrow keys, and Scroll knob. 	  
Range	0.0kHz to 3.0GHz * Arrow keys and Scroll knob resolution: 1/10 of span	

Set start frequency

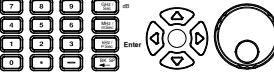
Panel operation	<ol style="list-style-type: none"> 1. Press the Frequency key. 2. Press F2 (Start). 3. Enter the value using the Numerical and Unit keys, Arrow keys, and Scroll knob. 	  
Range	0kHz to 3GHz (start frequency ≤ stop frequency) Arrow keys and Scroll knob resolution: step value	
Note	Center frequency and span settings automatically change according to start and stop frequency settings, and vice versa.	

Display

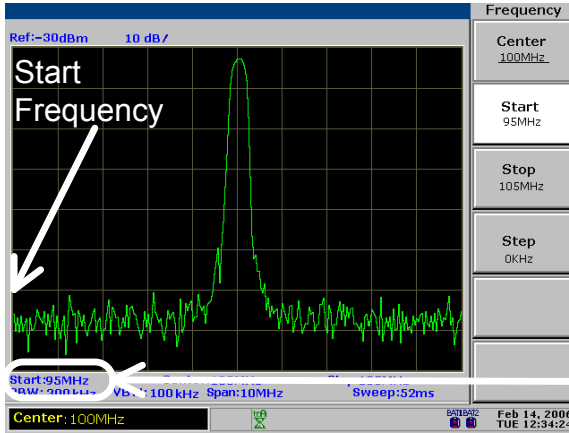

Frequency reading

Set stop frequency

- Panel operation** 1. Press the Frequency key.



2. Press F3 (Stop).

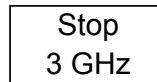

3. Enter the value using the Numerical and Unit Keys, Arrow keys, and Scroll knob.

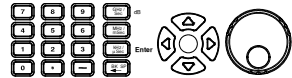

Range

0.0kHz to 3.0GHz (start frequency \leq stop frequency)

* Arrow keys and Scroll knob resolution: step value

Display

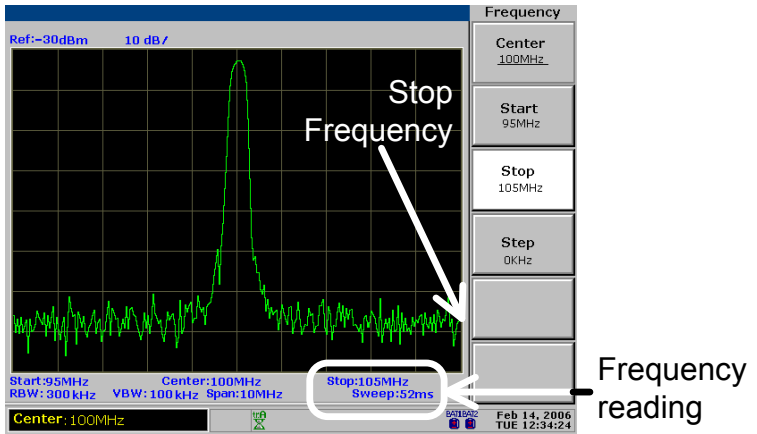

Note

Center frequency and span settings automatically change according to start and stop frequency settings, and vice versa.

Full/Zero Span

Full or zero span setting sets the span to extreme values: 3GHz (full) or 0kHz (zero). They provide faster ways to view signals in certain situations, such as in time domain (zero span) for viewing modulation or in full span for viewing signals with unknown frequencies.

Display full frequency span (3GHz)

Panel operation 1. Press the Span key.



2. Press F2 (Full Span).



Range 3GHz (fixed)

Full span also sets these parameters to fixed values.

- Center frequency: 1.5GHz
- Start frequency: 0.0kHz
- Stop frequency: 3.0GHz

Display

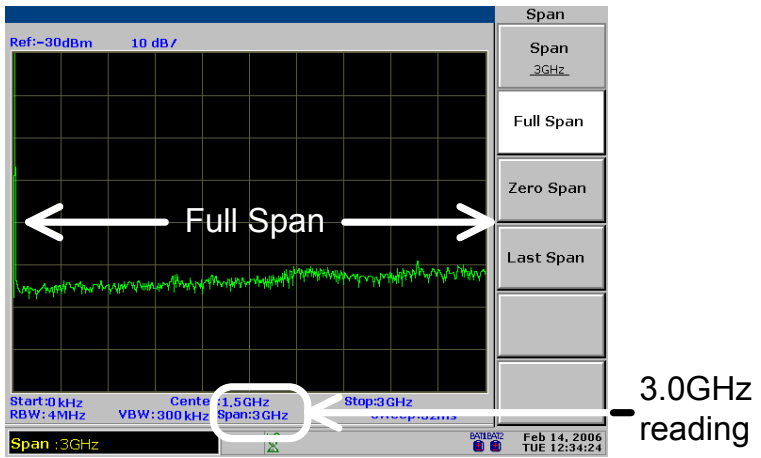

Display zero span (time domain)

Panel operation 1. Press the Span key.



2. Press F3 (Zero Span).



Range

Center frequency (fixed)

Zero span also sets these parameters to fixed values.

- Start frequency: same as the center frequency
- Stop frequency: same as the center frequency

Display

The diagram shows an example of observing the amplitude modulation of the input signal.

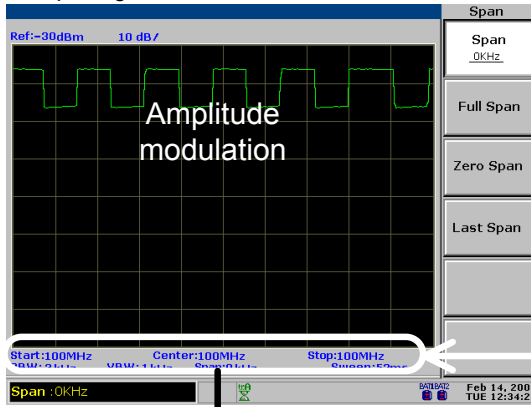

Start=
Center=
Stop
frequency

0kHz Span

Note

When using zero span for viewing amplitude modulation, make sure that the RBW setting is large enough. For RBW setting details, see page130.

Recall the Last Span Setting

Panel operation

1. Press the Span key.



2. Press F4 (Last Span).



3. The span setting goes back to the previous one.

Nesting level

1 level

AMPLITUDE

The **Amplitude key** sets the vertical attribute of the display, including the upper limit (reference level), vertical range (amplitude scale), vertical unit, and compensation for external gain or loss (external offset). Amplitude correction adjusts the frequency response distortion caused by external networks. The input impedance can also be adjusted according to the application needs.

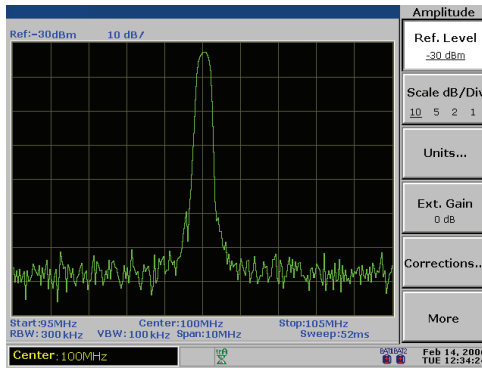

Vertical Scale Setting	Set reference amplitude	61
	Select amplitude scale	63
	Select amplitude unit	63
	Set external offset level	65
Amplitude Correction	Correct amplitude step by step	67
	Delete entire correction set data	71
	Recall existing correction set	72
	Save/copy/delete/rename correction file	73
Input Impedance	Select input impedance (50 Ω/75Ω)	73
	Set impedance offset (75 Ω only)	74

Set Vertical Scale

Vertical display scale is defined by the reference amplitude, amplitude range, measurement unit, and external gain/loss.

Set reference amplitude

The reference level defines the amplitude at the top of the displayed range (see below screen snapshot).

Panel operation 1. Press the Amplitude key.



2. Press F1 (Ref.Level).



3. Enter the value using the Numerical and Unit keys, Arrow keys, and Scroll knob.

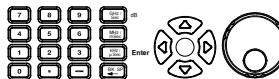

*Arrow keys and Scroll knob resolution: vertical scale

Range	dBm	-110 to +20 dBm, 0.1dB resolution
	dBmV	-63.01 to +66.99 dBmV, 0.01dB resolution
	dBuV	-3.01 to +126.99 dBuV, 0.01dB resolution

See page63 for selecting amplitude units.

Display

Reference Level Reading

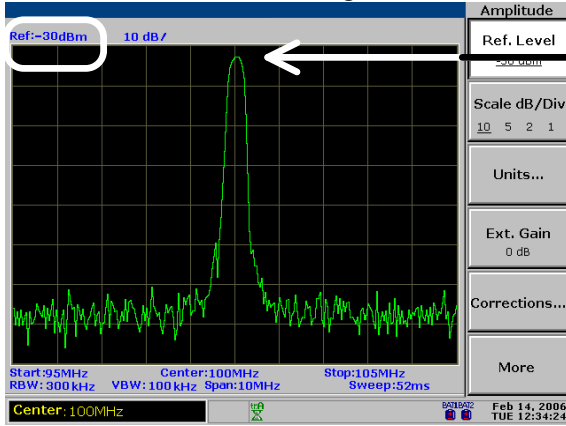

Reference level

Select amplitude scale

Panel operation 1. Press the Amplitude key.



2. Press F2 (Scale dB/Div) repeatedly to select the scale.

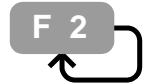
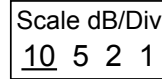

Range 10, 5, 2, 1 dB/Div

Display

Scale reading

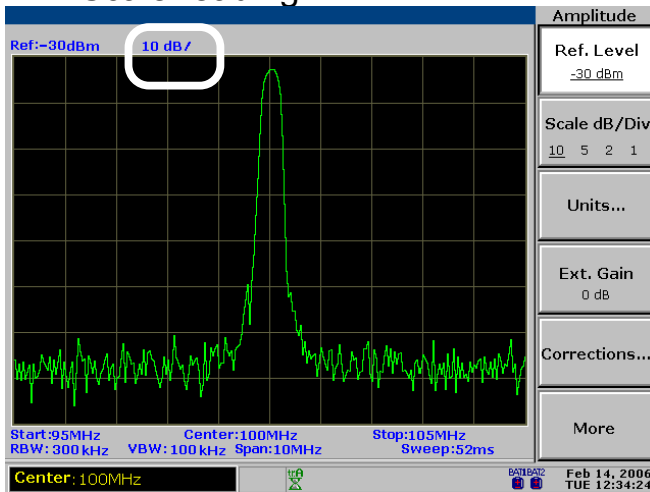

Select amplitude unit

Panel operation 1. Press the Amplitude key.



2. Press F3 (Units).

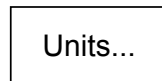

3. Select and press the unit from F1 (dBm), F2 (dBmV), and F3 (dBuV).

dBm **F 1**

dBmV **F 2**

dBuV **F 3**

4. Press F6 (Return) to go back to the previous menu.

Return **F 6**

Range	dBm	-110 to +20 dBm
	dBmV	-63.01 to +26.99 dBmV
	dBuV	-3.01 to +126.99 dBuV

Set external offset level

Background External offset compensates the amplitude gain or loss caused by an external network or device.

Panel operation 1. Press the Amplitude key.



2. Press F4 (Ext.Gain).

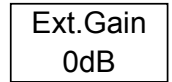

3. Enter the value using the Numerical keys and dB or Enter key.



Range -20.0dB to +20.0dB, 0.1dB resolution

Icon



The amplitude icon appears at the bottom of the display when the external offset changes.

Example Before (offset: 0dB)

Reference: -27dBm

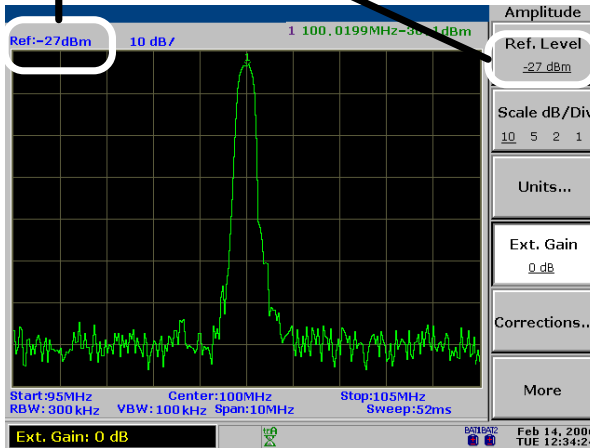

Offset: 0dB

After (offset: -3dB) Reference: -30dBm

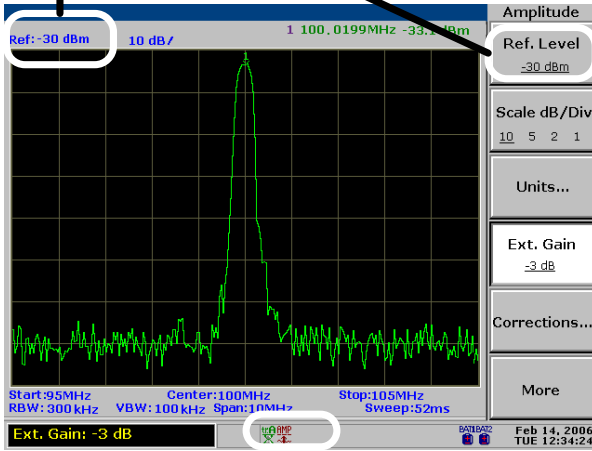

Offset:
-3dB

Amplitude Correction

Overview

Background	Amplitude correction adjusts the ISA830/ISA830TG's frequency response by changing amplitudes for specific frequencies.	
Range	Correction set	5 sets, 30 correction points each
	Amplitude	-40 to +40dB per correction point, 0.1dB resolution
	Frequency	9kHz to 3GHz, 1kHz resolution
Icon		The amplitude icon appears at the bottom of the display when amplitude correction is on.

Correct amplitude step by step

Example description	In this example, the network between the ISA830/ISA830TG and DUT distorts the waveform and pushes the amplitude down at around 2.4GHz. Amplitude correction can bring the amplitude back to its original level.	
Correction level	In this example the amplitude around 2.4GHz is boosted by +1 to +3dB as shown below.	
	2.2GHz	+2.5dB
	2.3GHz	+1.3dB
	2.4GHz	+2.8dB
	2.5GHz	+2.5dB
	2.6GHz	+1.2dB

**Waveform
(before
correction)**

The frequency response is distorted (non-flat) and the level is attenuated by 2 to 3dB.

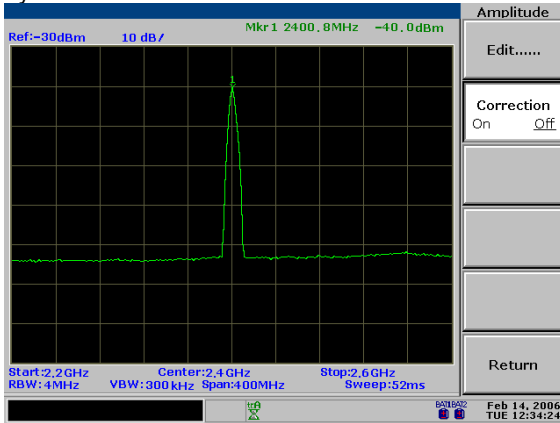

**1. Enter
correction edit
mode**

1. Press the Amplitude key.



2. Press F5 (Corrections).



3. Press F1 (Edit). The display shows the correction sets.

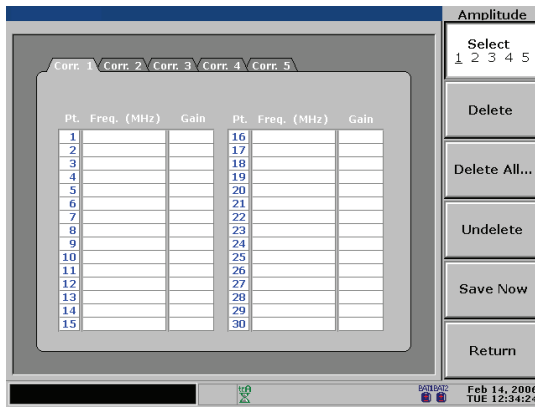

2. Select correction set

Press F1 (Select) repeatedly to select the correction set. 5 sets, 30 points each, are selectable.

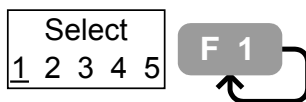

Example: correction set 3 selected

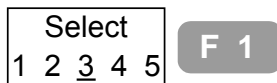

3a. Add correction point

1. Make sure that the cursor is pointing to the first empty frequency point.

Pt.	Freq. (MHz)	Gain
1		
2		
3		
4		
5		

2. If necessary, move the cursor using the Up/Down keys.



3. Enter the frequency using the Numerical and Unit keys: 9kHz to 3GHz.



4. The cursor automatically moves to the Gain side. Enter the gain using the Numerical keys and dB key. Range: -40dB to +40dB.

Pt.	Freq. (MHz)	Gain
1		2200
2		
3		
4		
5		



5. Repeat the above procedure for all correction data. The points are automatically sorted by frequency (low → high).

3b. Modify correction point

1. Move the cursor using the Arrow keys.



2. Enter the new frequency or gain using the Numerical keys and Unit keys or dB key.

Pt.	Freq. (MHz)	Gain
1	2200	2.5
2	2300	1.3
3	2400	2.8
4	2500	1.8
5	2600	1.2



3c. Delete correction point

1. Move the cursor to the target using the Arrow keys.



2. Press F2 (Delete). The frequency and gain are deleted together.

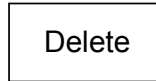

3. To undo the last deletion, press F4 (Undo).

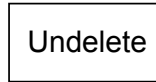

Example: point 3 deleted

Pt.	Freq. (MHz)	Gain
1	2200	2.5
2	2300	1.3
3	2400	2.8
4	2500	1.8
5	2600	1.2



Pt.	Freq. (MHz)	Gain
1	2200	2.5
2	2300	1.3
3	2500	1.8
4	2600	1.2
5		

4. Save correction set

1. Press F5 (Save Now). The edited data is saved internally.

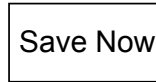

2. Press F6 (Return) to go back to the previous menu.



5. Activate correction

1. Press F2 (Correction On) to turn on the correction.

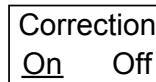

2. The amplitude icon appears at the bottom of the display.



After correction Frequency response becomes linear (original), and the gain is compensated by +2 to +3dB.

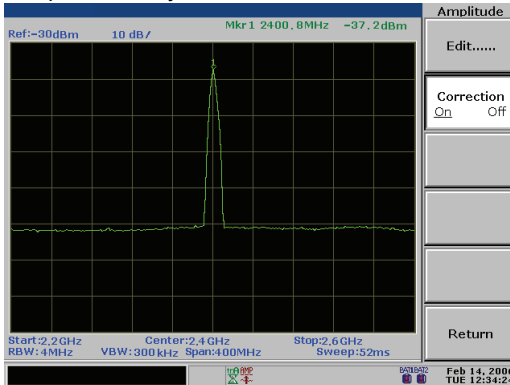

Delete entire correction set data

Panel operation 1. Press the Amplitude key.



2. Press F5 (Corrections).

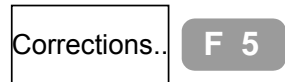

3. Press F1 (Edit). The display shows the correction sets.

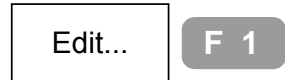

4. Press F1 (Select) repeatedly to select the correction set.

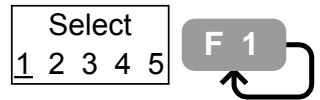

5. Press F3 (Delete All).

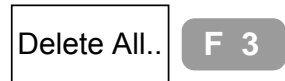

6. Press F2 (Yes). The whole data in the specified correction set is deleted. To cancel deletion, press F1 (No).

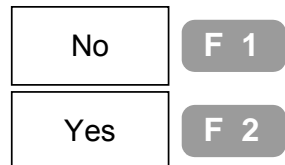

7. Press F6 (Return) repeatedly to go back to previous menus.



Recall existing correction set

- Panel operation** 1. Press the Amplitude key.



2. Press F5 (Corrections).



3. Press F1 (Edit). The display shows the correction sets.



4. Press F1 (Select) repeatedly to select the correction set.

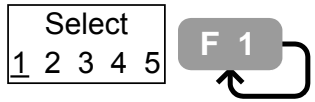







5. Press F6 (Return) to go back to the previous menu.

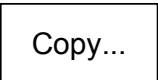

6. Press F2 (Correction On) to activate the correction data.

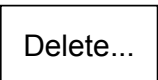

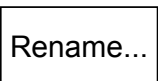



Save/copy/delete/rename correction file

Background	Correction files can be saved, copied, deleted, or renamed using the file utilities. Press the File key to access each function.	
Save/Copy	Press F1 (Copy). For detailed steps, see page152.	 
Delete	Press F2 (Delete). For detailed steps, see page157.	 
Rename	Press F3 (Rename). For detailed steps, see page159.	 

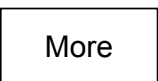

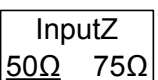

Set Input Impedance

Select input impedance (50Ω/75Ω)

Background	In most cases, the default 50Ω is appropriate. Use 75Ω when specifically required, such as in cable TV signals.	
Panel operation	1. Press the Amplitude key.	
	2. Press F6 (More).	 
	3. Press F1 (Input Z 50Ω/75Ω) to select the impedance.	 
	4. When 75Ω is selected, the amplitude icon appears at the bottom of the display.	

Set impedance offset (75Ω only)

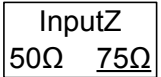
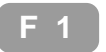
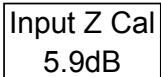
Background Impedance transformation to 75 Ω is also available through external devices such as an impedance converter module. In these cases an external loss will be induced. Impedance offset can compensate this effect.

Panel operation	1. Press the Amplitude key.	
	2. Press F6 (More).	 
	3. Make sure 75Ω is selected in F1 (Input Z).	 
	4. Press F2 (Input Z Cal).	 
	5. Enter the offset using the Numerical keys and dB or Enter key.	
Range	-10dB to +10dB, 0.1dB resolution	

AUTOSET

The **Autoset** function checks input signal characteristics and automatically searches the maximum peak signal, then sets up the suitable horizontal and vertical scale. The amplitude floor (which limits the search range) and frequency observation span (which limits the viewing range) are configurable according to the application needs.

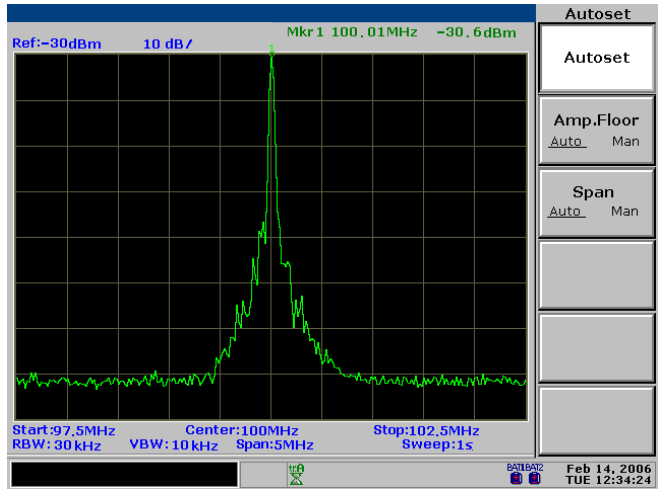

Overview	How Autoset Works	76
Run	Run Autoset	78
Limit Range	Limit vertical search range.....	79
	Limit horizontal view range	80

How Autaset Works

Description

The Autaset function searches the peak signals in two stages (full span & 0Hz - 100MHz limited span), picks up the signal peak with the maximum amplitude, and then shows it in the display. The following flowchart graphically shows the simplified procedures.

Flowchart

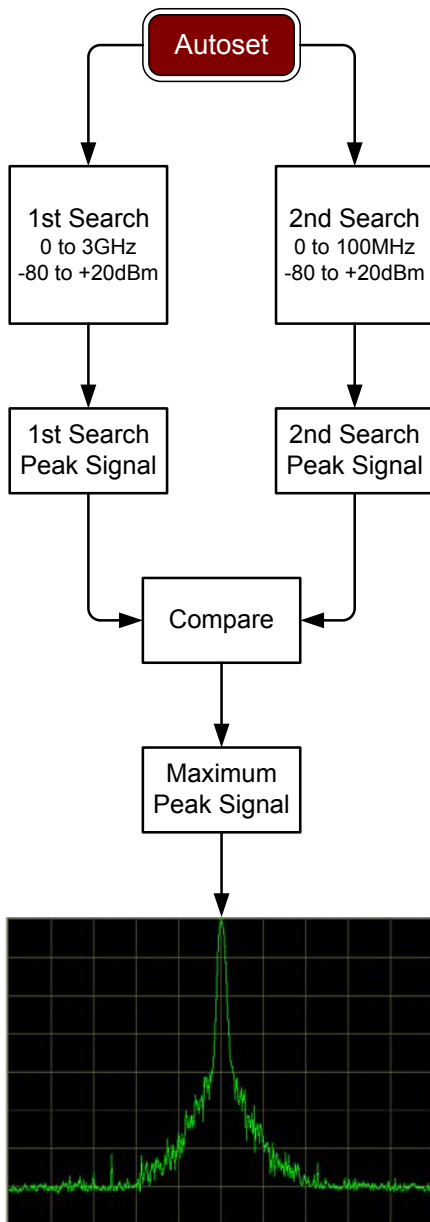

Run Autose

Panel operation 1. Press the Autose key.



2. Press F1 (Autose).

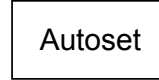

Search range	Amplitude	dBm	-80 to +20dBm
		dBmV	-33.01to+66.99dBmV
		dBuV	+26.99to+126.99dBuV
	Frequency	0kHz to 3.0GHz	

* These ranges are applicable when both Amplitude floor (F2) and Span limit (F3) are set to Auto.

Example: before Autose	Start frequency: 0kHz	Stop frequency: 3GHz
	Span: 3GHz	Signal peak: 100MHz
	Center frequency: 1.5GHz	Reference level: -30dBm

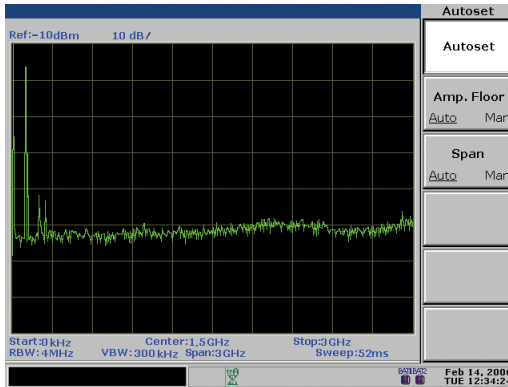

Example: after Autose	Start frequency: 97.5MHz	Stop frequency: 102.5MHz
	Span: 5MHz	Signal peak: 100MHz
	Center frequency: 100MHz	Reference level: -30dBm

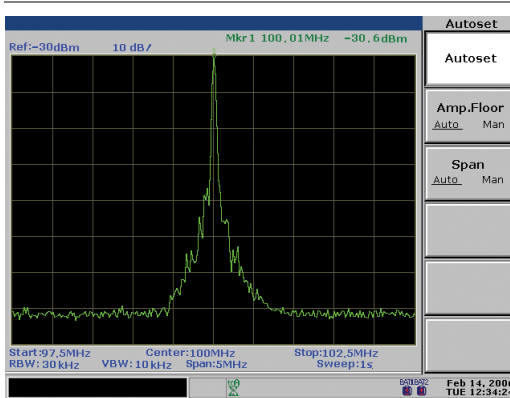

RBW/VBW /Sweep after Autoset



All the three BW related parameters, RBW, VBW, and Sweep, will be reset to Auto mode when using Autoset, regardless of their previous settings.

Limit vertical search range

Background

You can set the amplitude floor so that the signals lower than the setting will be ignored by the Autoset search.

Panel operation

1. Press the Autoset key.



2. Press F2 (Amp. Floor) to switch the range from Auto (whole range) to manual (limited range).

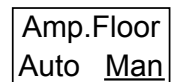

3. Enter the amplitude in dB using the Numerical keys and dB or Enter key. The Command window shows the setting.



Amp. : -30dBm

Range

dBm -80 to +20dBm, 0.1dB resolution

dBmV -33.01 to +66.99dBmV, 0.01dB resolution

dBuV +26.99 to +126.99dBuV, 0.01dB resolution

See page63 for selecting amplitude units.

Limit horizontal view range

Background You can change the frequency span limit in the display to get a better view of the Autoset result. By default, the frequency span after Autoset is set at 3MHz (Auto).

Panel operation 1. Press the Autoset key.



2. Press F3 (Span) to switch the range between Auto (3MHz fixed limit) to Manual.



3. Enter the frequency using the Numerical and Unit keys.



Range Zero span, 2kHz to 3GHz (Manual) 3MHz fixed (Auto)

MARKER

A **Marker** shows the frequency and amplitude of a waveform point. The ISA830/ISA830TG can activate up to 5 markers or marker pairs simultaneously. The marker table helps editing and viewing multiple markers in a single display. You can also enable/disable all markers at once. A delta marker shows the frequency and amplitude differences between the reference marker. The ISA830/ISA830TG can automatically move a marker to various locations including peak signal, center frequency, and start/stop frequency. More marker operations regarding signal peaks are also available in the **Peak Search** function.



Activate Marker(s)	Activate normal marker 82
	Activate all 5 normal markers at once 83
	Activate delta marker 84
Move Marker(s)	Move marker manually 85
	Move marker to highest peak 85
	Move marker and highest peak to center 87
	Move marker to various locations 87
	Move marker to trace 89
Marker Table	Show Markers in Table 89

Activate/de-activate marker

Range	Normal marker 5
	Delta marker 5 pairs
Amplitude	-120 to +20dBm, 0.1dB resolution -73.01 to +66.99dBmV, 0.01dB resolution -13.01 to +126.99dBuV, 0.01dB resolution
Frequency	0kHz to 3GHz

Activate normal marker

- Panel operation**
- Press the Marker key.
 

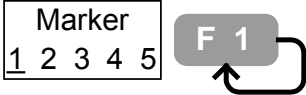
 - Press F1 (Marker) repeatedly to select the marker ID from 1 to 5.
 

 - Press F2 (On) and turn On the selected marker.
 

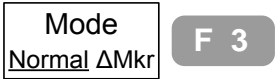
 - Make sure Normal is selected in F3. If necessary, press F3 and select it.
 

 - Repeat the above steps for the number of markers required.

Display

The upper right corner of the display shows the active marker.
Marker ID, Frequency, Amplitude

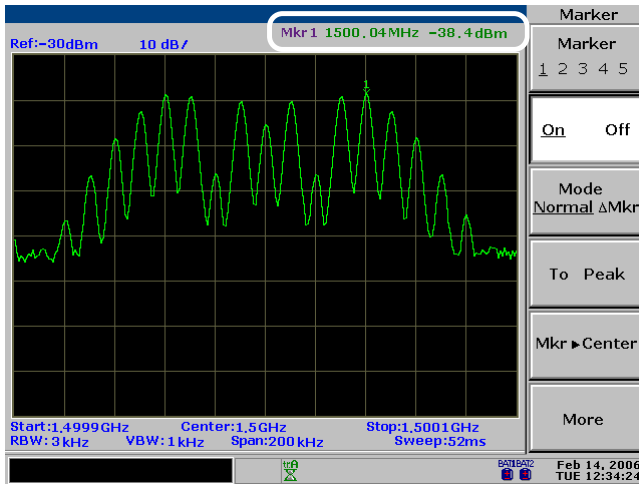

Activate all 5 normal markers at once

Panel operation 1. Press the Marker key.



2. Press F6 (More).



3. Press F3 (All Mkrs On) to turn On all 5 normal markers.



4. To view all marker status, press F2 (Marker Table On). The frequency and the amplitude of the markers appear in table list.

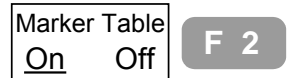

Display

The marker table shows all 5 marker frequencies and amplitudes.

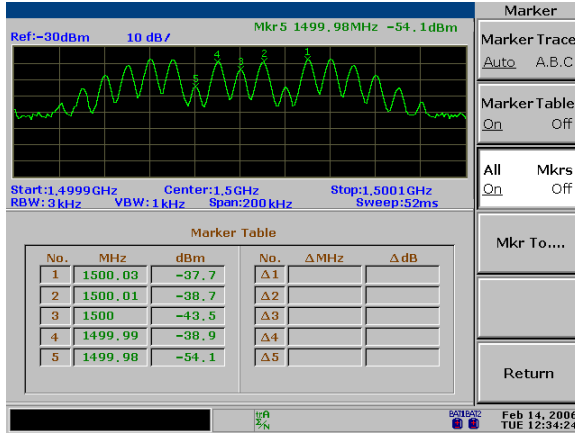

Activate delta marker

Panel operation

1. Press the Marker key.



2. Press F1 (Marker) repeatedly to select the marker ID from 1 to 5.

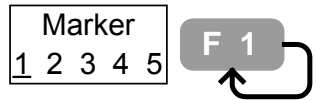

3. Press F2 (On) and turn on the selected marker.



4. Make sure ΔMkr is selected in F3. If necessary, press F3 and select ΔMkr.

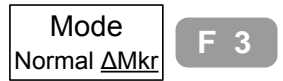

5. Repeat the above steps for the number of markers required.

Display

The upper right corner of the display shows the active delta marker pair.

Move marker

This section assumes at least one marker is already activated (page82). Marker frequency positions can be set manually, or can be automatically positioned at specific locations using the menu shortcuts.

Move marker manually

- Panel operation**
1. Check the active marker at the top right corner of the display.
 2. Move the marker using the Left/Right keys and Scroll knob, or directly enter the frequency using the Numerical and Unit keys.

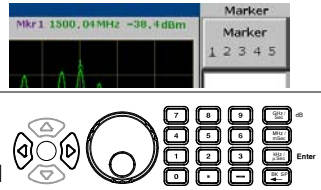

Move marker to highest peak

- Method 1**
1. Check the active marker at the top right corner of the display.



2. Press the Marker key.
3. Press F4 (To Peak).



- Method 2**
1. Alternatively, press the Peak Search key.



2. Press F1 (Pk Search).



- Method 3 (marker tracked to the peak)**
1. Another method moves marker to the peak and also tracks it. Press the Peak Search key.



2. Press F6 (More).



-
3. Press F4 and select Track On. The marker is tracked to the peak.

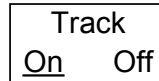

-
4. The peak tracking icon appears at the bottom of the display.



Move marker and highest peak to center

Method 1

1. Check the active marker at the top right corner of the display.

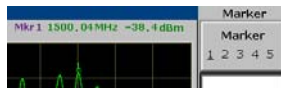

2. Press the Marker key.



3. Press F4 (To Peak). The marker moves to the signal peak.

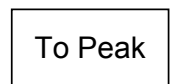

4. Press F5 (Mkr→Center). The signal peak moves to the center.



Method 2

1. Alternatively, press the Peak Search key.



2. Press F5 (Mkr→Center). The signal peak moves to the peak, then to the display center.

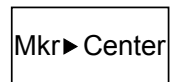

Move marker to various locations

Panel operation

1. Check the active marker at the top right corner of the display.



2. Press the Marker key.



3. Press F6 (More).

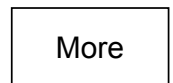

4. Press F4 (Mkr to...)

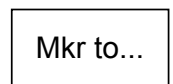

-
5. Select the destination and press F1 (Center) to F5 (Ref Lvl).

Center: center frequency

Start: start frequency

Stop: stop frequency

CF Step: set the marker frequency as the frequency step value

Ref Lvl: reference amplitude level

Mkr ▶ Center

F 1

Mkr ▶ Start

F 2

Mkr ▶ Stop

F 3

Mkr ▶ CFStep

F 4

Mkr ▶ Ref Lvl

F 5

-
6. Press F6 (Return) to go back to the previous menu.

Return

F 6

Display

The marker table shows all 5 marker frequencies and amplitudes.

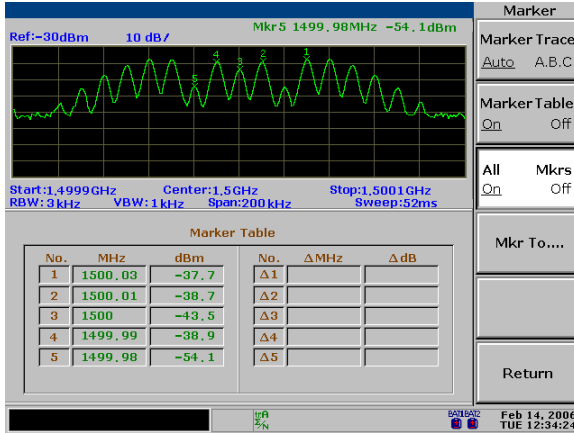

Activate delta marker

Panel operation

1. Press the Marker key.



2. Press F1 (Marker) repeatedly to select the marker ID from 1 to 5.

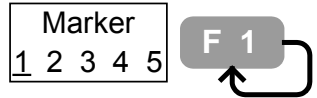

3. Press F2 (On) and turn on the selected marker.

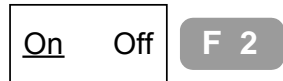

4. Make sure Δ Mkr is selected in F3. If necessary, press F3 and select Δ Mkr.

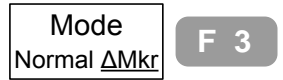

5. Repeat the above steps for the number of markers required.

Display

The upper right corner of the display shows the active delta marker pair.

Display

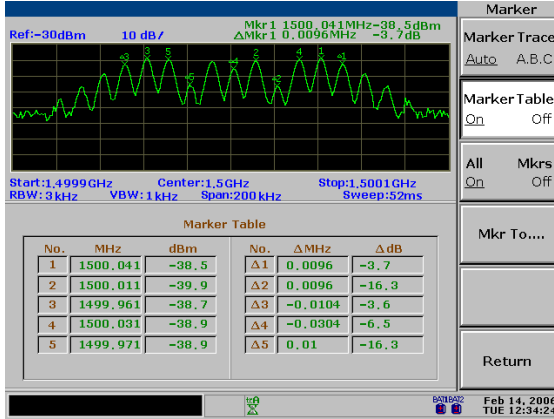

PEAK SEARCH

The **Peak search** function automatically locates signal peaks in various conditions, such as in next highest peak and minimum peak. The Peak Search overlaps its feature with the **Marker** function, and it is best to use the two together. All peaks can be viewed at once using the peak table, with configurable amplitude threshold and sorting order.

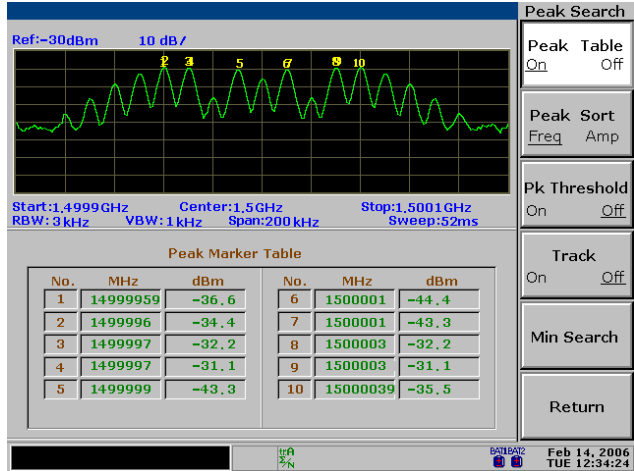

Search Signal Peaks	Search signal peak	92
	Search next highest peak	94
	Search highest peak and move to center	94
	Search minimum amplitude	96
Show Peak Table	Activate peak table	96
	Set peak threshold	97
	Sort peak	98





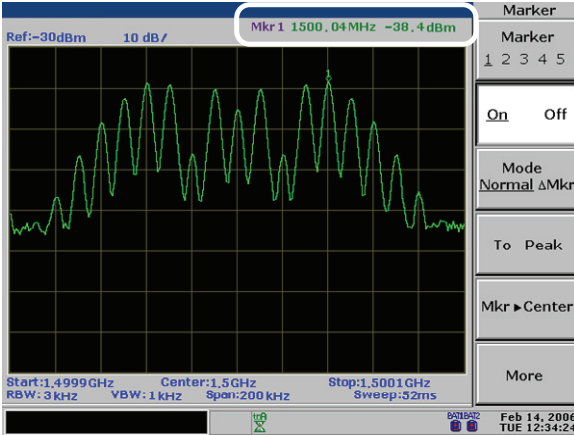

Search Signal Peak

Peak Search puts a marker on the target signal peak. If no marker has been activated, the ISA830/ISA830TG automatically activates marker 1. The peak signal frequency and amplitude appear at the top right corner of the display.

Marker ID, Frequency, Amplitude



Search signal peak

- | | | |
|--|---|--|
| Method 1 | 1. Press the Peak Search key. |  |
| | 2. Press F1 (Pk Search). |   |
| Method 2 | 1. Make sure that the marker is already activated. If not, press the Marker key. |  |
| | 2. Press F4 (To Peak). |   |
| Method 3 (marker tracked to the peak) | 1. Another method continuously tracks the peak signal. Press the Peak Search key. |  |

2. Press F6 (More).

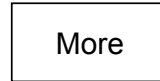

-
3. Press F4 (Track On). The marker is tracked to the peak signal.

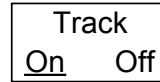

-
4. The peak tracking icon appears at the bottom of the display.



Search next highest peak

The marker keeps moving to the next highest peak, in descending order.

- Panel operation** 1. Press the Peak Search key.



2. Press F2 to F4 repeatedly.
Next Peak moves the marker to the next highest peak.
Next Pk Right moves the marker to the next highest peak on the right side (higher frequency).
Next Pk Left moves the marker to the next highest peak on the left side (lower frequency)

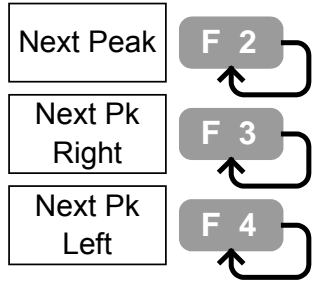

Display

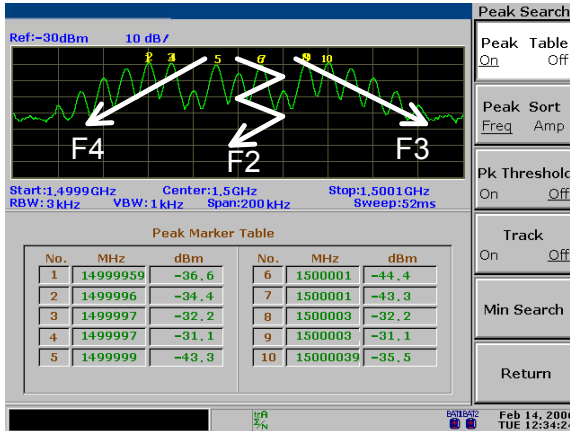

Search highest peak and move to center

- Method 1** 1. Press the Peak Search key.



2. Press F1 (Pk Search).



Method 2

1. Make sure that the marker is already activated. If not, press the Marker key.



-
2. Press F4 (To Peak).

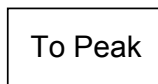

-
3. Press F5 (Mkr→Center).



Search minimum amplitude

Panel operation 1. Press the Peak Search key.



2. Press F6 (More).

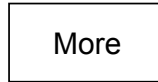

3. Press F5 (Min Search). The active marker moves to the deepest valley in the trace.

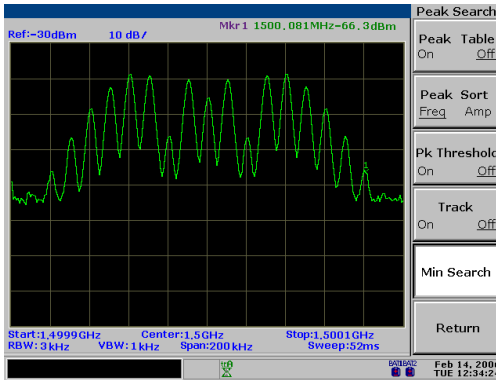
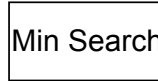

Show Peak Table

Activate peak table

Panel operation 1. Press the Peak Search key.



2. Press F6 (More).

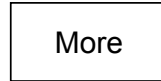

3. Press F1 (Peak Table On). The peak table appears in the lower half of the display.

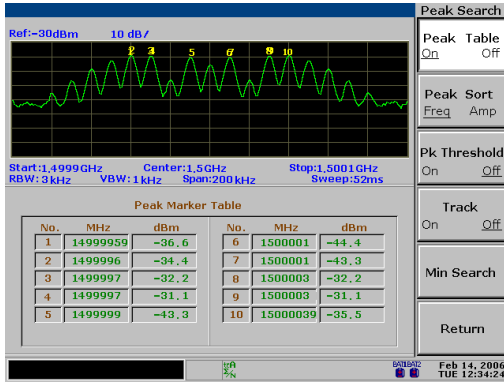
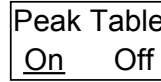

Range 10 peaks maximum

Set peak threshold

Only the peaks below the threshold amplitude will be listed in the table.

- Panel operation** 1. Press the Peak Search key.



2. Press F6 (More).

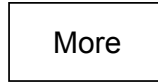

3. Press F1 (Peak Table On).

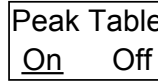

4. Press F3 (Pk Threshold On).

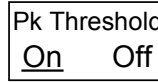

5. A horizontal line appears on the display. The ISA830/ISA830TG searches and lists the peaks below this threshold amplitude.

6. Use the Arrow keys or the Scroll knob to move the threshold line.

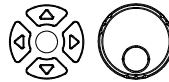

Sort peak

The peaks are sorted in ascending frequency or descending amplitude order.

- Panel operation** 1. Press the Peak Search key.



2. Press F6 (More).

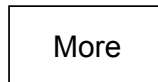

3. Press F2 (Peak Sort) to switch between frequency and amplitude sorting.

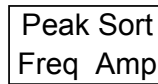

Example:
amplitude sort

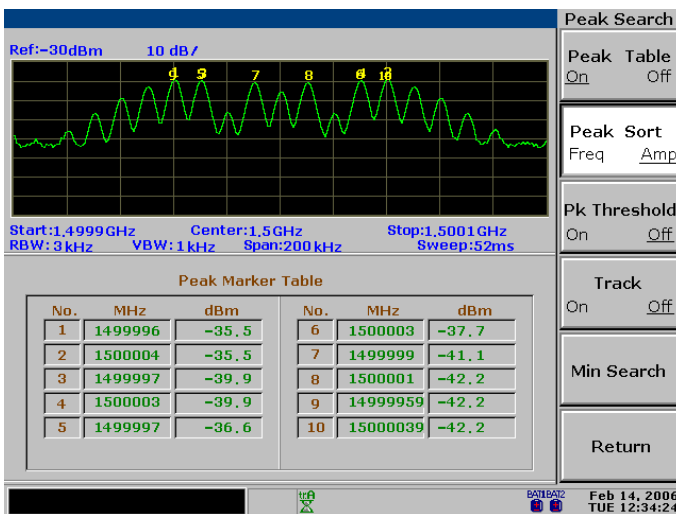

TRACE

A **Trace** keeps track of waveform variants. Three traces, A, B, and C, are available for accumulating the peak level, freezing the current waveform shape, and averaging the waveform. Trace math operations are available using trace A and B.

Detection modes configure the way the ISA830/ISA830TG samples the input analog signal for digitizing.

Trace

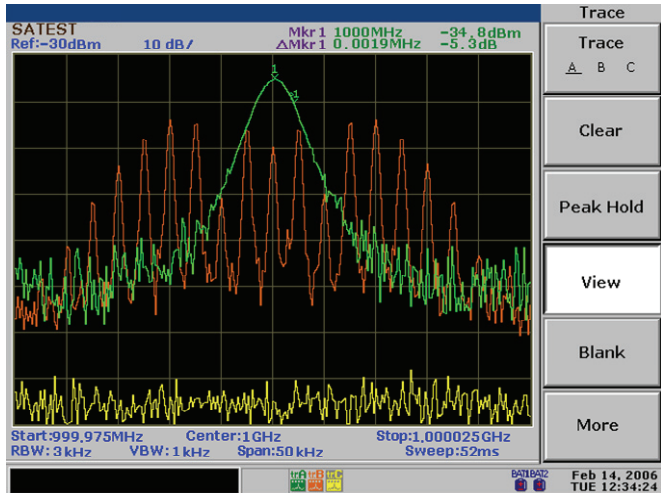



View Trace	Select (activate) trace.....	101
	View real-time updated trace (default)	101
	View peak-hold trace	101
	Freeze trace.....	102
	Hide trace	102
Move Trace	View averaged trace	103
	Move Marker to Trace	104
Trace Math	Save/copy/delete/rename trace file.....	105
	Run Trace Math	106
Detection Mode	Select Signal Detection Mode	109

View traced waveform

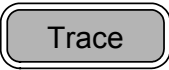
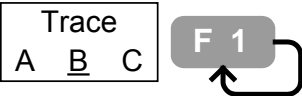
Select (activate) trace

Panel operation	1. Press the Trace key.	
	2. Press F1 (Trace) repeatedly to select the trace.	
Range	A (green)	The default trace which is always activated. Together with trace B, runs trace math operation (page106).
	B (amber)	Together with trace A, runs trace math operation (page106).
	C (yellow)	

View real-time updated trace (default)

Background	The trace is updated at every sweep. The old trace is cleared up and a new trace is drawn on the display according to the latest measurement.	
Panel operation	1. Press the Trace key.	
	2. Press F2 (Clear).	
	3. The clear mode icon appears at the bottom of the display.	

View peak-hold trace

Background	In the peak hold mode, the amplitude of the new trace is compared with the last one at each sweep. Only the higher amplitude replaces old trace points, thus holding the highest (peak) value.
-------------------	--

Panel operation 1. Press the Trace key.



2. Press F3 (Peak Hold).



3. The peak hold trace icon appears at the bottom of the display.



Display

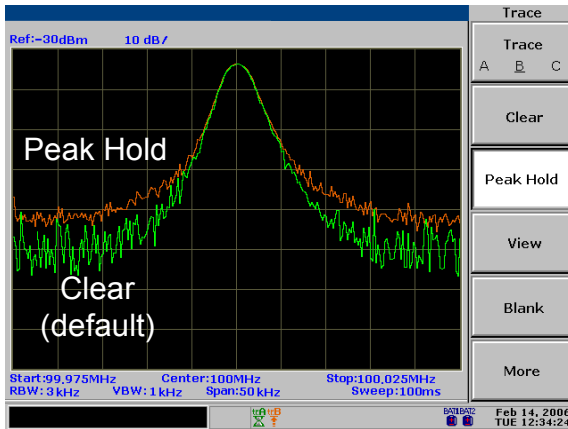

Freeze trace

Panel operation 1. Press the Trace key.

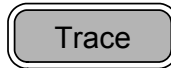

2. Press F4 (View). The trace shape and location becomes fixed.



3. The view mode (freeze) icon appears at the bottom of the display.



Hide trace

Panel operation 1. Press the Trace key.



2. Press F5 (Blank). The trace disappears from the display.



3. To bring back the trace again, press F2 (Clear).



View averaged trace

- Panel operation (Method1)**
1. Press the Trace key.

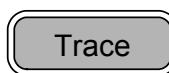

2. Press F6 (More).



3. Press F1 (AVG On) to turn on the average mode.



4. The average mode icon appears at the bottom of the display.



5. Enter the average number using the Numerical keys and Enter key.



- Panel operation (Method2)**
1. Press the BW key.



2. Press F4 (AVG On) to turn on averaging.

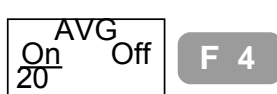

3. Enter the average time using the numerical keys and Enter key.



Range 1 to 200

Example: after average

Averaged 20 times

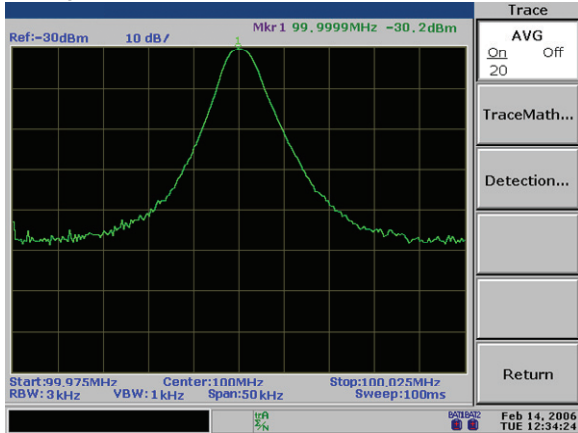

Move Marker to Trace

Panel operation

1. Check the active marker at the top right corner of the display.

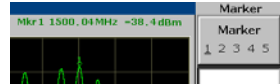

2. Press the Marker key.



3. Press F6 (More).

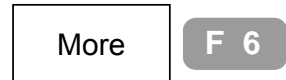

4. Press F1 (Marker Trace).

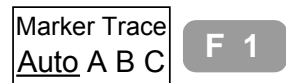

Range

Auto

The marker moves to the active signal or trace.

TraceA

The marker moves to TraceA.

TraceB

The marker moves to TraceB.

TraceC

The marker moves to TraceC.

Display

Marker on TraceC

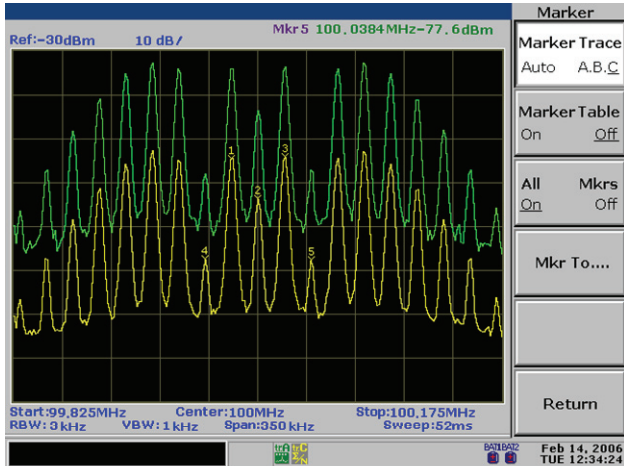

Save/copy/delete/rename trace file

Background

Trace files can be saved, copied, deleted, or renamed using the file utility. Press the File key to access each function.



Save/Copy

Press F1 (Copy). For detailed steps, see page152.

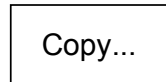

Delete

Press F2 (Delete). For detailed steps, see page157.



Rename

Press F3 (Rename). For detailed steps, see page159.

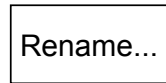

Run Trace Math

Background

Various mathematical operations are available using trace A and trace B. Both traces have to be activated in advance (page101). After the math operation, the trace mode changes into the View mode (page102).

Panel operation

1. Press the Trace key.



2. Press F6 (More).

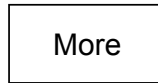

3. Press F2 (Trace Math).



4. Select and press the type of math operation from F1 to F5.
A↔B: Swaps trace A and B.
A+B→A: Adds trace A and B.
A-B→A: Subtracts trace B from trace A.
A+const→A: Adds a constant value to trace A.
A-const→A: Subtracts a constant value from trace A.

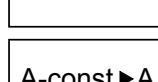
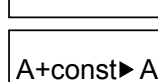
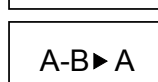
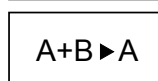

5. When **A+const / A-const** are selected, enter the constant value using the Numerical keys and dB or Enter key.
 Range: -40 to +40dB



6. The trace math icon appears at the bottom of the display.



Example: A↔B

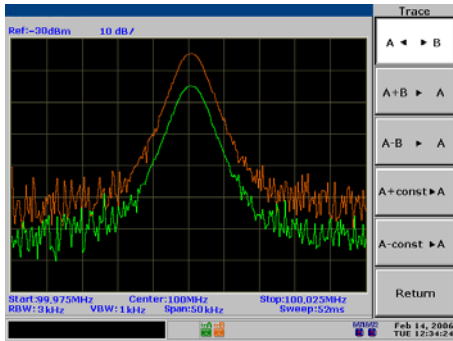
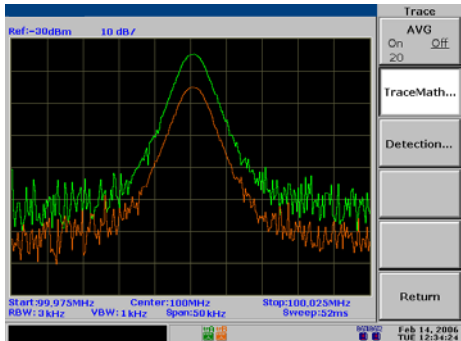

Example: A+B→A

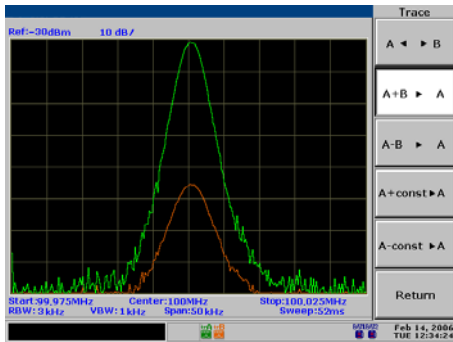
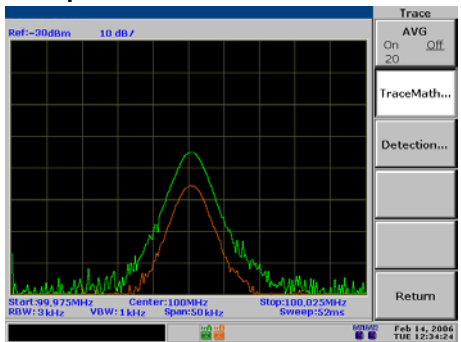

Example: A-B→A

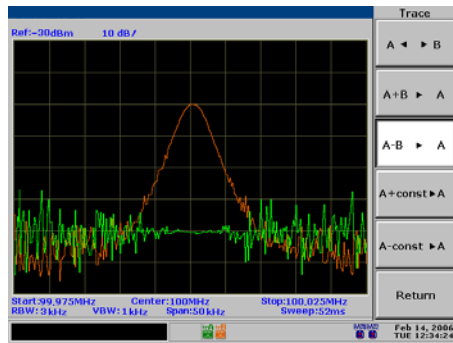
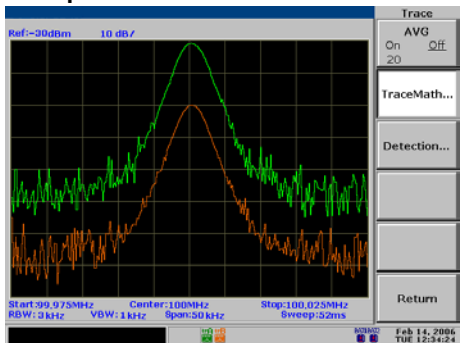

Example: A+constant→A (5 dB)

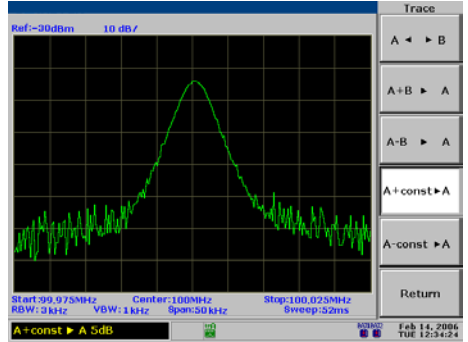
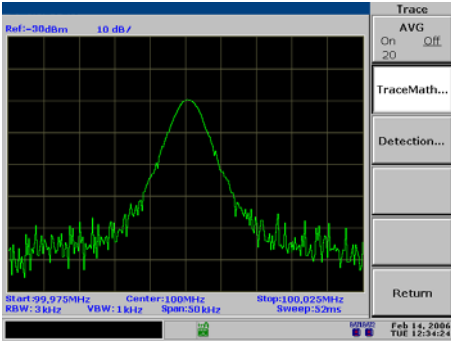



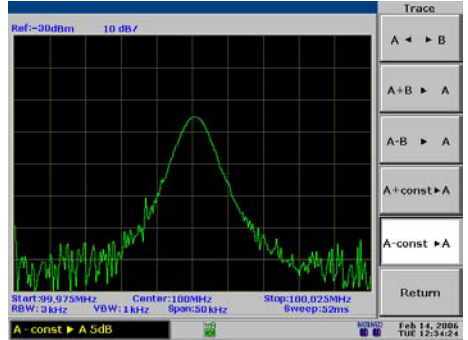
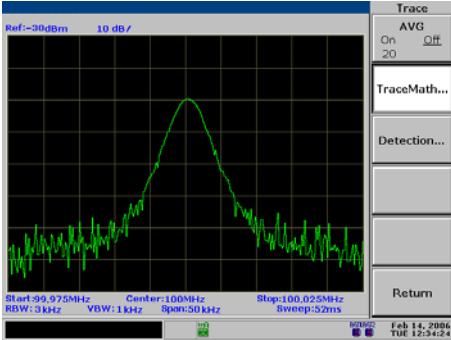



Example: A-constant→A (5 dB)

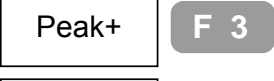

Select Signal Detection Mode

Background In order to show the incoming signal on the display, the ISA830/ISA830TG first converts the input signal to a video signal, digitizes it, then uses a detector to pick up the samples for display. By configuring the detection mode, certain signals can be viewed more clearly and/or sharply.

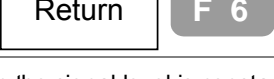
Panel operation	1. Press the Trace key.	
	2. Press F6 (More).	
	3. Press F3 (Detection).	
	4. Select the signal detection type from F1 to F5 and press it. See below for the description of each type.	
		
		
		
		
5. Press F6 (Return) to go back to the previous menu.		

Parameter	Normal	The default mode. When the signal level is constantly increasing or decreasing, the positive peaks are detected. Otherwise, detecting mode switches between positive peak and negative peaks. Useful for picking up burst phenomenon while avoiding excessive noise.
------------------	---------------	--

Sample	Detects signals randomly. Useful when detecting noise-like signals, but tends to miss burst phenomenon.
Peak+ (positive peak)	Detects positive peak signals. Useful for detecting sinusoid signals, but tends to pick up more noise than other modes.
AVG (average)	Not supported.
QPeak (quasi-peak)	Not supported

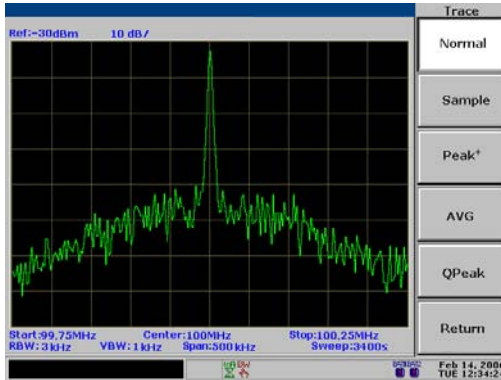
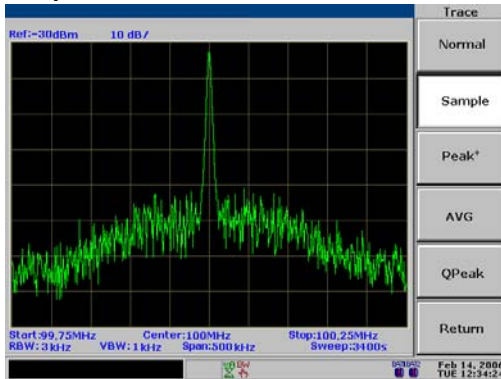
Example**Normal detection mode****Sample detection mode**

Peak+ detection mode

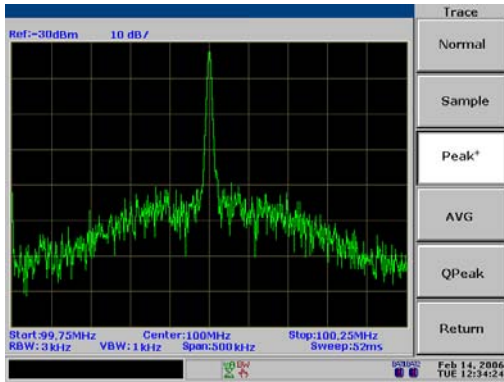

ACPR Measurement

Overview

Background	ACPR (Adjacent Channel Power Ratio), or ACLR (Adjacent Channel Leakage Ratio), refers to the amount of leakage power coming from the main radio channel which affects adjacent channels as signal distortion.	
Parameter	Channel bandwidth	The frequency bandwidth the target channel occupies. Range: 0kHz to Current span
	Channel space	The frequency distance between each main channel. Range: 0kHz to 3GHz
	Adjacent channel bandwidth 1 & 2	The frequency bandwidth the adjacent channels occupy. Range: 1kHz to 3GHz
	Adjacent channel offset 1 & 2	The frequency distance between the adjacent channels and main channel. Range: 1kHz to 3GHz

ACPR measurement step

1. **Activate ACPR** 1. Press the Measurement key.

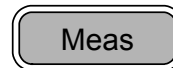

2. Press F2 (ACPR On).

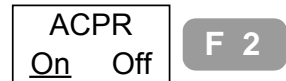

3. The display switches to ACPR mode, updating the ACPR results in the lower half of the display.

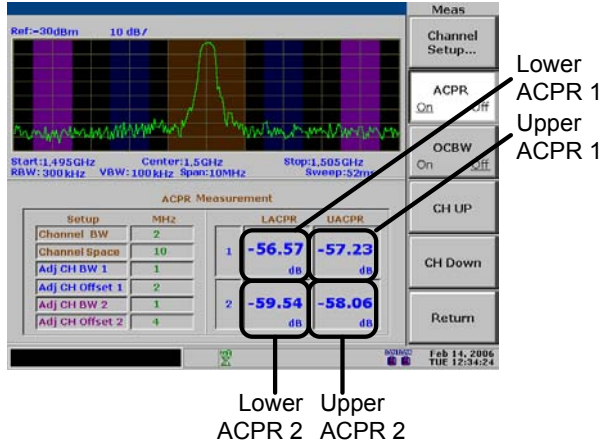

2. Set channel BW

1. Press F1 (Channel Setup).



2. Press F1 (CH BW).



3. Enter the channel BW using the Numerical and Unit keys.
Range: 0kHz to Current span



4. The value is updated in the Channel BW column in MHz.



Note:

- If the span (page53) becomes less than the CHBW setting, the warning “Span is less than CHBW!” appears in the command window.
- If the CHBW is 0kHz, the warning “CHBW is zero!” appears in the command window.





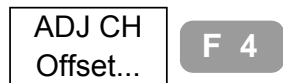



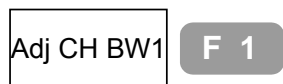

3. Set adjacent channel1 bandwidth

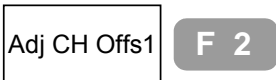
1. Press F4 (ADJ CH Offset).

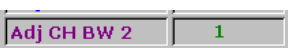
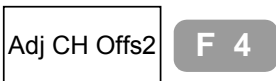

2. Press F1 (Adj CH BW1).

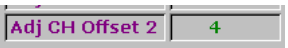

	3. Enter the adjacent channel 1 bandwidth using the Numerical and Unit keys. Range: 1kHz to 3GHz	
	4. The value is updated in the Adj CH BW1 column in MHz.	
4. Set adjacent channel1 offset	1. Press F2 (Adj CH Offs1).	
	2. Enter the adjacent channel1 offset using the Numerical and Unit keys. Range: 1kHz to 3GHz	
	3. The value is updated in the Adj CH Offset1 column in MHz.	
5. Set adjacent channel2 bandwidth	1. Press F3 (Adj CH BW2).	
	2. Enter the adjacent channel2 bandwidth using the Numerical and Unit keys. Range: 1kHz to 3GHz	
	3. The value is updated in the Adj CH BW2 column in MHz.	
6. Set adjacent channel2 offset	1. Press F4 (Adj CH Offs2).	
	2. Enter the adjacent channel 2 offset using the Numerical and Unit keys. Range: 1kHz to 3GHz	
	3. The value is updated in the Adj CH Offset2 column in MHz.	
7. Set channel space	1. Press F2 (Channel SPC).	
	2. Enter the channel space using the Numerical and Unit keys. Range: 0kHz to 3GHz	

3. The value is updated in the Channel Space column in MHz.

Channel Space	10
---------------	----

8. Move channel up/down

1. Press F6 (Return) twice.

Return	F 6
--------	-----

x2

2. Press F4 (CH Up) or F5 (CH Down) to switch the measurement to the next channel.

CH Up	F 4
-------	-----

CH Down	F 5
---------	-----

OCBW Measurement

Overview

Background OCBW (OCcupied BandWidth) refers to the bandwidth of the channel that consumes (occupies) the specified amount of power.

Parameter	Channel bandwidth	The frequency bandwidth that the target channel occupies. 0kHz to Current span
	Channel space	The frequency distance between each main channel. 0kHz to 3GHz
	OCBW %	The ratio of occupied bandwidth as the amount of power consumed. 0% to 100%, 0.1% resolution

OCBW measurement step

1. Activate OCBW 1. Press the Measurement key.

Meas

2. Press F3 (OCBW On).

OCBW On Off	F 3
----------------	-----

3. The display switches to OCBW mode, updating the OCBW result in the lower half of the display.

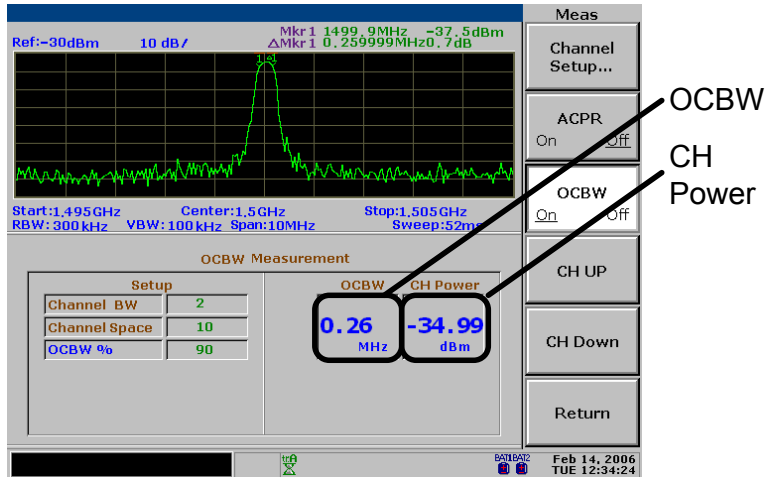

2. Set channel BW

1. Press F1 (Channel Setup).

Channel Setup...

F 1

2. Press F1 (CH BW).

CH BW

F 1

3. Enter the channel BW using the Numerical and Unit keys.
Range: 0kHz to Current span



4. The value is updated in the Channel BW column in MHz.



Note:

- If the span (page53) becomes less than the CHBW setting, the warning "Span is less than CHBW!" appears in the command window.
- If the CHBW is 0kHz, the warning "CHBW is zero!" appears in the command window.

3. Set OCBW %

1. Press F3 (OCBW %).

OCBW %

F 3

2. Enter the OCBW % using the Numerical keys and Enter key.
Range: 0% to 100%



3. The value is updated in the OCBW % column.



4. Set channel space

1. Press F2 (Channel SPC).



2. Enter the channel space using the Numerical and Unit keys.
Range: 0kHz to 3GHz



3. Space column updates the value in MHz.

**5. Move channel up/down**

1. Press F6 (Return) twice.



2. Press F4 (CH Up) or F5 (CH Down) to switch the measurement to the next channel.



NdB Measurement

Background N dB refers to the frequency bandwidth of a channel that covers the specified amplitude.

Parameter **N dB** 0.1dB to 80dB, 0.1dB resolution

1. Activate N dB 1. Press the Measurement key.

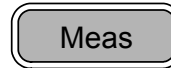

2. Press F6 (More).



3. Press F1 (N dB BW On).



4. The display switches to N dB mode, updating N dB result in the lower half of the display.

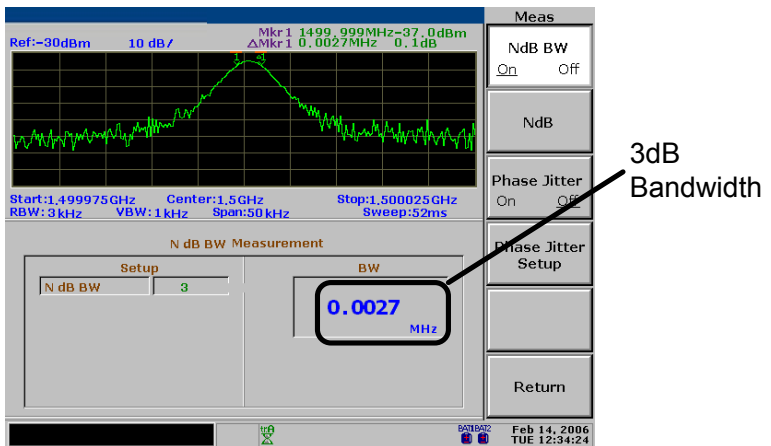

2. Set amplitude 1. Press F2 (NdB) to set the amplitude which the BW covers.







2. Enter the amplitude using the Numerical keys and dB or Enter key. Range: 0.1dB to 70dB



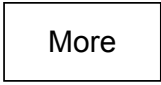

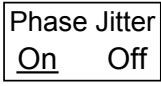
Phase Jitter Measurement

Background	Phase Jitter refers to the amount of phase fluctuation that leads to shortening or lengthening the center frequency.	
Parameter	Start offset	Beginning frequency offset in reference to the center frequency. 0kHz to 1/2 of span, 0.1MHz resolution
	Stop offset	End frequency offset in reference to the center frequency. 0kHz to 1/2 of span, 0.1MHz resolution

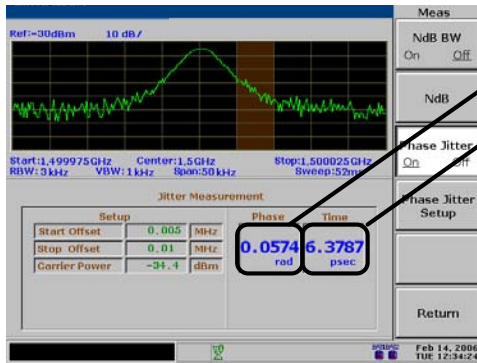
- 1. Activate Phase Jitter**
1. Press the Measurement key. 
 2. Press F6 (More).  
 3. Press F3 (Phase Jitter On).  
 4. The display switches to Phase jitter mode, updating Phase jitter result in the lower half of the display.

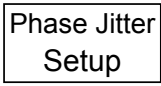

- 2. Set start/stop offset**
1. Press F4 (Phase Jitter Setup).  

-
2. Press F1 (Start Offset) and F2 (Stop Offset) to set the amount of the beginning and end offset.

Start
Offset

F 1

Stop
Offset

F 2

-
3. Enter the offset using the Numerical/Unit keys.
Range: 0kHz to $\frac{1}{2}$ of span



LIMIT LINE

A **Limit Line** sets the upper and lower amplitude limit over the entire frequency range. Limit lines can be used to detect whether the input signal level is above, below, or within the specified amplitude. The result, pass or fail, is shown at the bottom of the display in real-time.

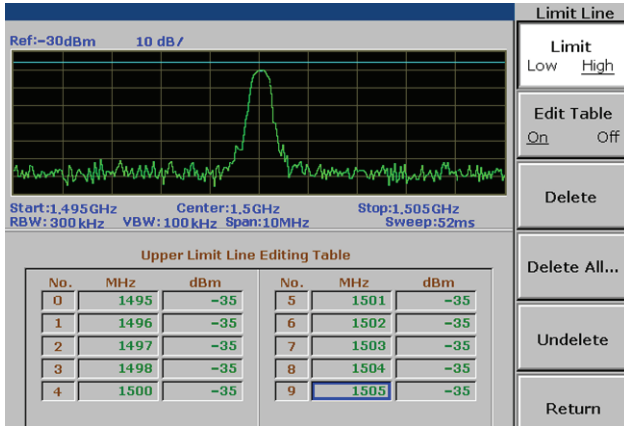

Edit	Edit Limit Line	123
Pass/Fail Test	Run Pass/Fail test	127
Limit Line File	Save/copy/delete/rename limit line file	128

Edit Limit Line

Parameters	Editing point	Maximum 10 points for each limit line, high or low.
Frequency	9kHz to 3GHz per editing point.	
Amplitude	Per editing point:	-130 to +20dBm -83.01dBmV to +66.99dBmV -23.01dBuV to +126.99dBuV

1. Activate Limit Line

1. Press the Limit Line key.



2. Press F1 (H Limit On) and/or F2 (L Limit On) to activate the high and/or low limit line.



3. The limit line appears on the display.
Blue: — H limit line
Yellow: — L limit line

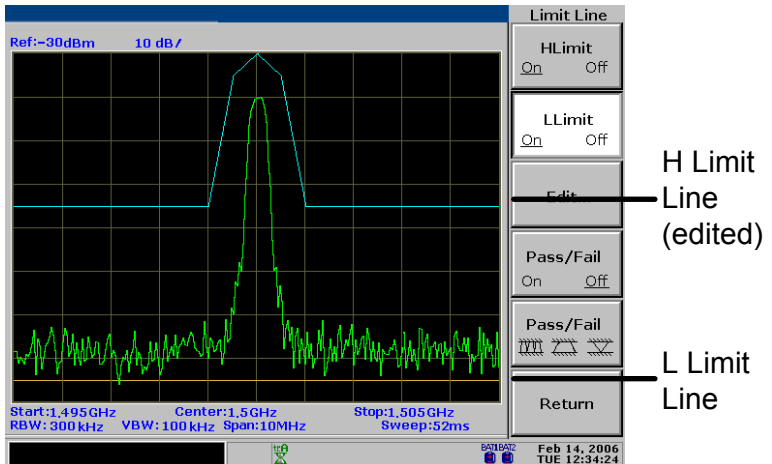

2a Activate limit line editing table

1. Press F3 (Edit).



- Press F1 (Limit) to select the limit line to be edited.

Limit
 Low High

F 1

- Press F2 (Edit Table On). The editing table appears in the lower half of the display.

Edit Table
On Off

F 2

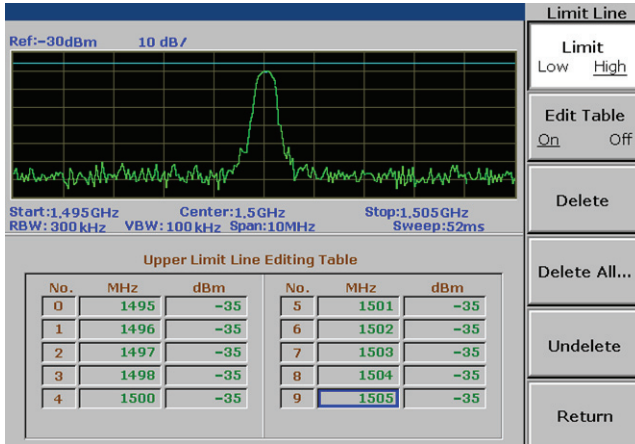

- Deactivating limit line table** Press F2 (Edit Table Off). The editing table disappears and the edited contents will be saved.

Edit Table
 On Off

F 2

3a. Add a limit line point

- Make sure that the cursor is pointing to the first empty frequency point. Use the Up/Down keys to move the cursor, if necessary.
10 points are available for each high and low limit line.

No.	MHz	dBm
1		
2		
3		
4		
5		



- If necessary, move the cursor to different frequency points using the Arrow keys.



- Enter the frequency using the Numerical and Unit keys.
Range: 9kHz to 3GHz
The value is displayed in MHz.



4. The cursor automatically moves to the dBm side. Enter the gain in using the Numerical keys and dB or Enter key. Range: -130dBm to +20dBm

No.	MHz	dBm
1	98	
2		
3		
4		
5		

5. Continue the above steps for the number of points required.

3b. Delete a limit line point

1. Move the cursor using the Arrow keys.



2. Press F3 (Delete) to delete the point (frequency and amplitude together).



No.	MHz	dBm
1	98	-40
2	100	-30
3	102	-40
4		
5		



No.	MHz	dBm
1	98	-40
2	102	-40
3		
4		
5		

3. To undo deletion, press F5 (Undelete).



3c. Delete the whole limit line data

1. Press F4 (Delete All).



2. Press F1 (No) or F2 (Yes) to confirm deletion. All 10 limit line points will be deleted at once.

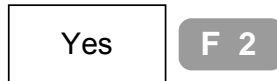

3. Press F6 (Return) to go back to the previous menu.

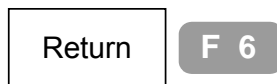

4. To undo deletion, press F5 (Undelete).



4. Switch upper/lower limit line

If necessary, press F1 (Limit) to start editing the other limit line. Repeat the above steps.

Limit
 Low High

F 1

Example

High Limit Line

Point No.	Frequency (MHz)	Amplitude (dBm)
1	98MHz	-40dBm
2	100MHz	-30dBm
3	102MHz	-40dBm

Resulted line

Ref: -30dBm 10 dB/

Limit Line
 Limit
 Low High

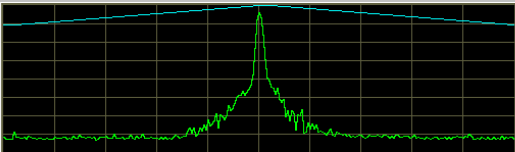

Start: 98MHz Center: 100MHz Stop: 102MHz
 RBW: 30kHz VBW: 10kHz Span: 4MHz Sweep: 100ms

Upper Limit Line Editing Table

No.	MHz	dBm	No.	MHz	dBm
0	98	-40	5		
1	100	-30	6		
2	102	-40	7		
3			8		
4			9		

MHz :

DATAZ Feb 14, 2006
 TUE 12:34:24

Limit

Edit Table

Delete

Delete All...

Undelete

Return

Run Pass/Fail test

This section assumes that the limit line is already defined.

Pass/Fail condition

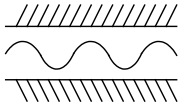
 Checks whether the entire waveform amplitude stays between the high limit and low limit lines.

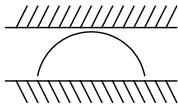
 Checks whether the peak waveform amplitude stays between the high and low limit lines.

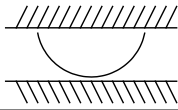
 Checks whether the waveform valleys stay between the high and low limit lines.

1. Select condition

1. Press the Limit Line key.



2. Press F5 (Pass/Fail) repeatedly to select the condition.

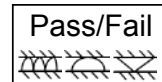

2. Run Pass/Fail test

1. Press F4 (Pass/Fail On) to activate the test.

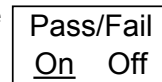







2. The test result appears at the bottom of the display.

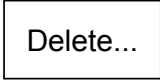

Note

If the limit lines are not defined, the Pass/Fail test uses the highest or lowest display level as the limit line.

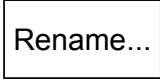
Save/copy/delete/rename limit line file

Background	Limit line files can be saved, copied, deleted, or renamed using the file utility. Press the File key to access each function.	
Save/Copy	Press F1 (Copy). For detailed steps, see page152.	 
Delete	Press F2 (Delete). For detailed steps, see page157.	 
Rename	Press F3 (Rename). For detailed steps, see page159.	 

BANDWIDTH

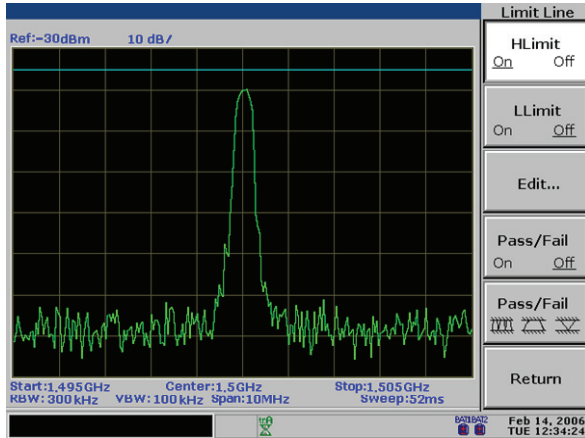

The **BW (BandWidth)** feature configures how narrow the ISA830/ISA830TG can sort out different signal peaks (resolution), and how fast the display can be updated (sweep time). Averaging the waveform is also available for smoothing noise level. The resolution, sweep time, and averaging are in a trade-off relationship, so configuration should be done with care.



RBW/VBW	Select RBW (Resolution BandWidth).....	130
	Select VBW (Video BandWidth)	131
	RBW/VBW Auto Mode Contents.....	132
Sweep Time	Set Sweep time	134
Average	Average Waveform.....	134
Reset	Reset RBW/VBW/sweep time to auto	136

Select VBW (Video BandWidth)

Background VBW (Video Bandwidth) defines the smoothness of the trace on the display. Combined with RBW, VBW defines the ability to sort out target signal from surrounding noise or adjacent peaks. See page132 for suitable VBW selection.

- Panel operation**
1. Press the BW key. 
 2. Press F2 (VBW) to select Auto or Manual. 
 3. When Man (manual) is selected, use the Arrow keys or Scroll knob to select the VBW. The selected VBW appears in the command window. 

Mode

Auto VBW is automatically selected. See page132 for setting.

Manual VBW is manually selected. The VBW icon appears at the bottom of the display. 

Range 10Hz to 1MHz in 1-3 steps

In Auto mode, VBW is automatically selected in combination with RBW. See page132 for the settings. Use the Auto mode settings for reference when manually selecting the VBW.

Note The ISA830/ISA830TG automatically changes the VBW according to RBW selection.

RBW/VBW Auto Mode Contents

Background

- The following applies when selecting Auto mode for RBW and VBW setting. Use them as a reference when manually selecting RBW and VBW.

Check the RBW installation status

1. Press the System key.



2. Press F6 (More).

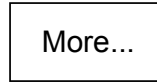

3. Press F4 (System Config On) to turn on the system configuration window.

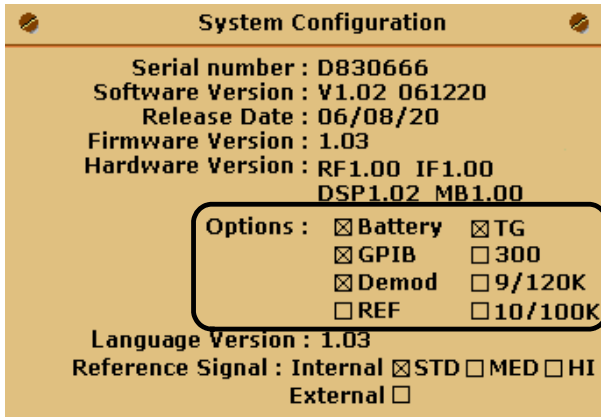
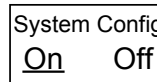

← Optional Items

4. Press F4 (System Config Off) to close the system configuration.

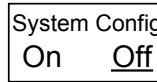

Standard configuration	Item	Install	Icon
	(9k/120k RBW) (Not supported)	No	<input type="checkbox"/> 9/120K
	300Hz RBW (Not supported)	No	<input type="checkbox"/> 300

	10k/100kHz RBW (Not supported)	No	<input type="checkbox"/> 10/100K	
	(Logarithmic scale, unit in Hz)			
VBW	10k	10k	100k	300k
RBW	3k	30k	300k	4M
Span 0	300k	6M	60M	3G

Set Sweep time

Background Sweep time defines the display update rate. Note that sweep time and RBW/VBW are in trade-off. Faster sweep time updates display more frequently but makes RBW and VBW wider, reducing the capability to separate signals at close frequencies.

Panel operation 1. Press the BW key.



2. Press F3 (Swp tm) To switch between Auto and Manual setting.

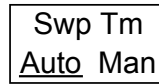

In the Manual mode, the manual sweep time icon appears.

3. When Manual mode is selected, enter the sweep time using the Numerical/Unit keys.



Mode **Auto** Sweep time is automatically set.

Manual Sweep time is manually set.

Range 50ms to 25.6s, 1us resolution

Note When in the Auto mode, ISA830/ISA830TG is optimized for fast sweep time. For narrower RBW settings, like 3 KHz, this optimization will cause slightly higher phase noise. To reduce the phase noise level, slow down the sweep time using manual setting.

Average Waveform

Background The ISA830/ISA830TG averages the waveform for a user-defined or system-defined number before it is displayed. This feature smoothes the noise level to a great extent, but slows down the display update rate.

Panel operation (Method1) 1. Press the BW key.



2. Press F4 (AVG On) to turn on averaging. The current average number setting appears in the command window.

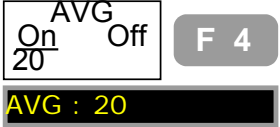

3. The trace average icon appears at the bottom of the display.



4. Enter the average time using the Numerical keys and Enter key.



Panel operation (Method2)

1. Press the Trace key.



2. Press F6 (More).



3. Press F1 (AVG On) to turn on the average mode. The current average number setting appears in the command window.

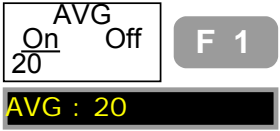

4. The average mode icon appears at the bottom of the display.



5. Enter the average number using the numerical keys followed by the Enter key.



Parameter **2 to 200** (Available only when Average is on)

AVG number after power on/preset After powering up the ISA830/ISA830TG (page24) or presetting it (page50), the average number is reset to 20 (AVG itself is turned off)

Reset RBW/VBW/sweep time to auto

Panel operation 1. Press the BW key.



2. Press F5 (All Auto). The RBW, VBW, and sweep time setting all change to Auto.



RBW/VBW/Sweep Setting after Autoset When using the Autoset, all three BW related parameters, RBW, VBW, and sweep, will be reset to Auto mode, regardless of their previous settings.

TRIGGER

The **Trigger** function sets the signal conditions upon which the ISA830/ISA830TG triggers capturing waveforms, including frequency, amplitude, and delay. An external trigger signal, instead of the default internal signal, may be used as required for special conditions.

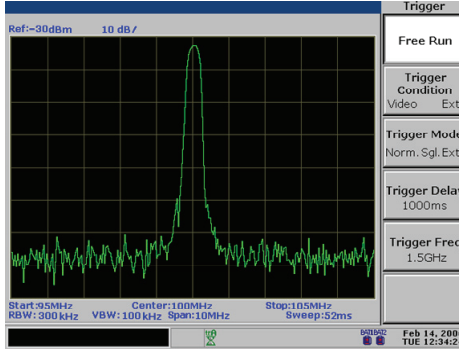

Free Run	Select free run (default)	138
Video Trigger	Activate video trigger	138
External Trigger	Activate external trigger	139
Trigger Mode	Select Trigger Mode	139
Trigger Delay	Set Trigger Delay	141

Select Trigger Type

Select free run (default)

In the free run mode, the ISA830/ISA830TG captures all incoming signals (no triggering condition).

Panel operation 1. Press the Trigger key.



2. Press F1 (Free Run).



Activate video trigger

Panel operation 1. Press the Trigger key.



2. Press F2 (Trigger Condition Video).



3. The video trigger icon appears at the bottom of the display.



4. Enter the trigger level (amplitude) using the Numerical keys and dB or Enter key. The value appears in the command window.



5. Press F5 (Trigger Freq) to set the frequency at which the ISA830/ISA830TG checks the trigger condition.
Default value: center frequency

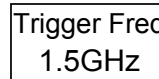

6. Enter the trigger frequency using the Numerical/Unit keys.



Deactivate video trigger To de-activate video triggering, press F1 (Free Run).



Level range (Ref.Level – 80dBm) to Ref.Level

(Example: when the reference level is –30dBm, the trigger range will be –110dBm to –30dBm)

Frequency range 0 to 3GHz

Activate external trigger

Panel operation 1. Press the Trigger key.



2. Press F2 (Trigger Condition Ext.).

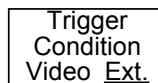

3. The Ext. trigger icon appears at the bottom of the display.



4. Connect the external trigger signal to the rear panel terminal.

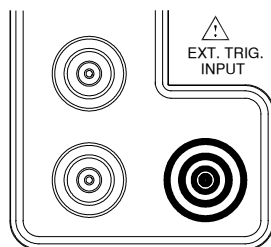

Input level range 0V to 5V, positive edge trigger

Select Trigger Mode

Panel operation 1. Press the Trigger key.



2. Press F3 (Trigger Mode) repeatedly to select the trigger mode.

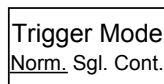

3. Press F6 (Run Now) to manually start triggering.

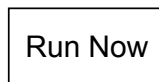

Modes	Normal	The ISA830/ISA830TG captures signals every time the triggering condition occurs.
	Single	The ISA830/ISA830TG captures signals when the first triggering condition occurs, then stops capturing altogether.
	Continuous	The ISA830/ISA830TG captures signals when the first triggering condition occurs, then switches to Free Run mode. After then, input signals are captured continuously regardless of their conditions.

Set Trigger Delay

Background Trigger delay sets the amount of time between the moment of trigger condition and when the ISA830/ISA830TG starts capturing signal.

Panel operation 1. Press the Trigger key.



2. Press F4 (Trigger Delay).

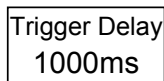

3. Enter the delay time using the Numerical/Unit keys.



Delay range 10us to 100s, 1us resolution



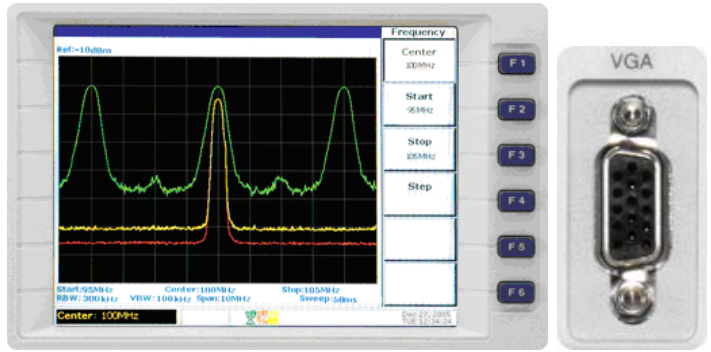

DISPLAY

The **Display** setting configures the LCD screen dimmer level, display line, display title, and split window. Display line provides a convenient reference line for measuring amplitude. Split window allows two simultaneous waveforms to be shown on the display. The VGA connector on the rear panel outputs the LCD screen contents in 640x480 resolution.





LCD Dimmer	Change Display Brightness	143
Display Line	Activate Display Line	143
Title	Enter Display Title	144
Split Window	Use Split Display	145
VGA Output	Use VGA Output	147
Save	Save Display Image to USB Flash Drive	147

Change Display Brightness

- Panel operation**
1. Press the Display key. 
 2. Press F1 (LCD Dimmer).  
 3. Change the brightness using the Left/Right keys or Scroll knob.  
- Range** 0 (darkest) to 5 (brightest)

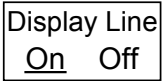
Activate Display Line

- Panel operation**
1. Press the Display key. 
 2. Press F2 (Display Line On).  
 3. The display line appears on the display and its level appears in the command window. 

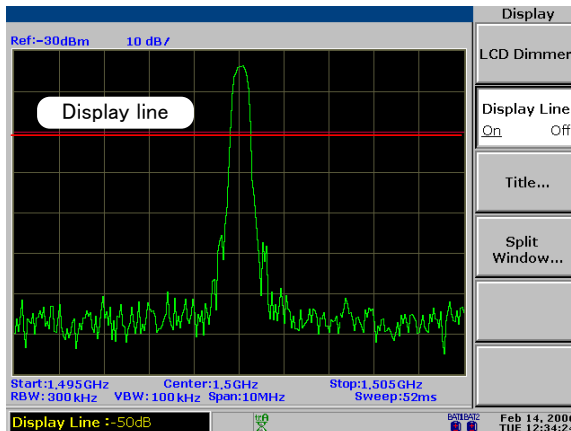

4. Move the line using the Left/Right keys or Scroll knob.



Note Display line is NOT available in the following situations.

- Split window (page145)
- Limit Line editing (page123)
- Power measurements (page112)

Enter Display Title

- Panel operation** 1. Press the Display key.



2. Press F3 (Title).



3. Select the character from F2 to F4 and press it. (When entering numbers 0 to 9, press one from F2 to F4 anyway)

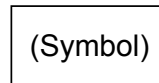
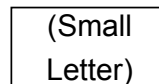
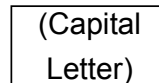

4. Here is how to type in the capital letter "S". Press F2 (Capital Letter) repeatedly until the cursor reaches S.

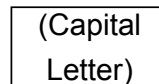

5. Press the Enter key. S appears in the command window.



To enter the number "2", press the number 2 key.



To delete (undo) previously entered character, press the BK SP key.



6. Continue the above until all the characters are entered.

TL SATEST
(SATEST)

7. Press F5 (Show Title).

Show Title **F 5**

8. The entered title appears at the top left corner of the display.

9. To erase the title, press F1 (Clear Title).

Clear Title **F 1**

Parameter	Capital letter	Upper case alphabet, A to Z.															
	Small letter	Lower case alphabet, a to z.															
	Number	0 to 9.															
	Symbol	Commonly used 14 symbols as shown below.															
		<table style="width: 100%; text-align: center;"> <tr> <td>\</td> <td>#</td> <td>/</td> <td>_</td> <td>-</td> </tr> <tr> <td>.</td> <td>*</td> <td>:</td> <td>&</td> <td>(</td> </tr> <tr> <td>)</td> <td><</td> <td>></td> <td>%</td> <td></td> </tr> </table>	\	#	/	_	-	.	*	:	&	()	<	>	%	
\	#	/	_	-													
.	*	:	&	(
)	<	>	%														

Use Split Display

- Panel operation** 1. Press the Display key.



2. Press F4 (Split Window).

Split Window... **F 4**

- The display splits into upper and lower screen. The lower display retains the original vertical and horizontal scale. The upper display shows full scale.

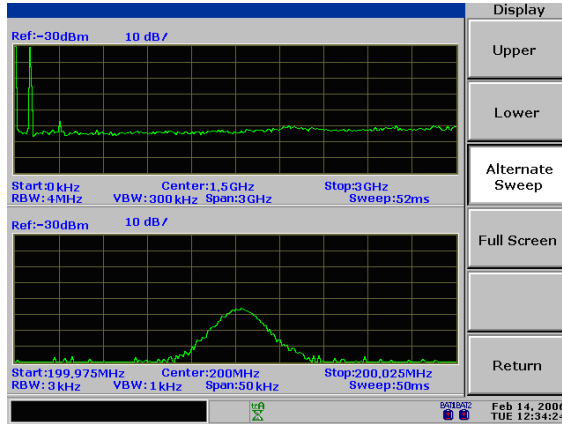

- Select the active display (in which the waveform is updated) by pressing F1 (Upper) or F2 (Lower). Pressing F3 (Alternate Sweep) updates both displays alternately.

Upper	F 1
Lower	F 2
Alternate Sweep	F 3

- To go back to the original single display, press F4 (Full Screen). The currently active window is expanded.

Full Screen	F 4
-------------	-----

Note Switching to the Full Screen from the Alternate Sweep mode is not recommended, since it is not predictable which display, upper or lower, will be selected.

Use VGA Output

Panel operation Connect an external monitor to rear panel VGA output terminal. The display output is always on.

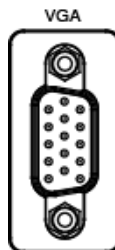

Parameter **Connector type** VGA 15pin, female

Resolution 640 x 480

Save Display Image to USB Flash Drive

Panel operation 1. Connect the USB flash drive to the front panel USB terminal. The USB icon appears at the bottom of the display.



Compatibility USB 1.1/2.0

Connector TypeA host, female

Note



If it takes more than 2 seconds for the USB icon to appear, disconnect the USB flash drive and connect again.

2. Press the File key.



3. Press F4 (Print Screen).

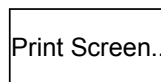

4. Press F1 (To Ext. Memory).

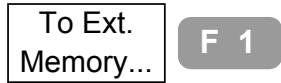

5. The USB flash drive contents appear in the display.

File Function:	Print to File	Memory	External
Item Name	Date	Remark	
MyFolderA	2007/03/06 09:48		
MyFolderB	2007/01/12 14:45		
MyResultA	2007/06/06 10:29		

6. To enter into an existing folder, move the cursor to the folder and press the Enter key.



7. To save the display image, move the cursor to the blank area using the Up/Down keys and press F2 (Print Now). A new bitmap file (MyBMapx.bmp) is created in the USB flash drive.



File Function:	Print to File	Memory	External
Item Name	Date	Remark	
MyFolderA	2007/03/06 09:48		
MyFolderB	2007/01/12 14:45		
MyResultA	2007/06/06 10:29		
MyBMap0			





Note If the cursor is pointing to an existing file, the file will be overwritten.

8. A confirmation message appears in the command window. To accept saving, press the Enter key. To cancel saving, press the BK SP key.



9. The file is saved when the date information appears. Now it is safe to remove the USB drive from the ISA830/ISA830TG.

File Function: Print to File		Memory External
Item Name	Date	Remark
 MyFolderA	2007/03/06 09:48	
 MyFolderB	2007/01/12 14:45	
MyResultA	2007/06/06 10:29	
MyBMap0	2007/07/10 15:30	



FILE

The **File** function manages file operations; copy, delete, and name change. The file format and contents include trace waveform, limit line, amplitude correction, sequence set (user defined macro), and panel settings. The file source and destination are selectable between internal (inside the ISA830/ISA830TG) and external (inside the USB flash drive). The File function can also save display images to USB flash drives.



File Operation	File Location and File Type	151
	Copy File	152
	Delete File	157
	Rename File	159
	Save Display Image to USB Flash Drive	161

File Location and File Type

File location	Internal	The ISA830/ISA830TG internal memory. The number of files and their names are fixed (see below).
	External	<p>The USB flash drive connected to the front panel connector. There is no practical limit on the number of files.</p>  <p> The USB icon turns on when the flash drive is detected.</p> <p>Compatibility: USB 1.1/2.0</p> <p>Connector: TypeA host</p>
	 Note	If it takes more than 2 seconds for the USB icon to appear, disconnect the USB flash drive and connect again.
File type	Trace	Trace waveform data. For details, see page100. File format: *.tra 13 files are available internally: TraceA/B/C (current trace), Trace 1to10 (stored trace).
	Limit	Limit Line data. For details, see page122. File format: *.lmt 12 files are available internally: LimitHL (current high limit line), LimitHL1 to 5 (stored high limit line), LimitLL (current low limit line), LimitLL1 to 5 (stored low limit line).
	Correction	Amplitude correction data. For details, see page67. File format: *.cor 5 files are available: Correction 1 to 5.
	Seq.	Sequence data. For details, see page180. File format: *.seq 10 files are available: Sequence 1 to 10.

Setup Panel setup data. For details, see page166.
 File format: *.set
 10 files are available: Setup 1 to 10.

Copy File

- 1. Connect USB flash drive (for external file)** When using the USB flash drive (external file) for source or destination, connect the drive to the front panel connector.



The USB icon turns on when the flash drive is detected.

- 2. Select source file** 1. Press the File key.



2. Press F1 (Copy). The file copy window appears.

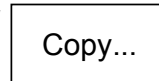

Source			
File Function:	Copy	Type:	Memory
Item Name		Date	Remark

3. Press F1 (Source).

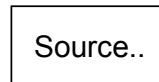

4. Select the file type from F1 to F5, press it, and then select Int (internal) or Ext (external). The display gets updated accordingly. The below example shows the internal trace files.

Trace Int. Ext.	F 1
Limit Int. Ext.	F 2
Correction Int. Ext.	F 3
Seq. Int. Ext.	F 4
Setup Int. Ext.	F 5

Source			
Item	Name	Date	Remark
	TraceA		
	TraceB		
	TraceC		

5. Use the Up/Down keys to move the cursor to the source file location. (Example: Internal TraceC selected)



Source			
Item	Name	Date	Remark
	TraceA		
	TraceB		
	TraceC		

6. Press F6 (Return). The copy source file information is retained.

Return	F 6
--------	-----

3. Select destination file

1. Press F2 (Destination). The destination file copy window becomes active in the lower half of the display.

Destination..	F 2
---------------	-----

- Select the file type from F1 to F5, press it, and select Internal or external. The file type must be the same as the source type. The display updates accordingly.

Trace	
Int.	Ext.

F 1

Source			
File Function: Copy		Type: Trace	Memory Internal
Item	Name	Date	Remark
	TraceA		
	TraceB		
	TraceC		
	Trace1		Emptv
	Trace2		Emptv
	Trace3		Emptv
	Trace4		Emptv

Destination			
File Function: Copy		Type: Trace	Memory Internal
Item	Name	Date	Remark
	TraceA		
	TraceB		
	TraceC		
	Trace1		Emptv
	Trace2		Emptv
	Trace3		Emptv
	Trace4		Emptv

- Use the Up/Down keys to move the cursor to the copy destination file location. (Example: internal Trace1 selected)



Destination			
File Function: Copy		Type: Trace	Memory Internal
Item	Name	Date	Remark
	TraceA		
	TraceB		
	TraceC		
	Trace1		Empty

When selecting an external location, select a blank space or an existing folder (a new file will be created inside).

Destination			
File Function:	Copy	Type: Trace	Memory External
Item Name	Date		Remark
 MyFolderA	2007/03/06 09:48		
 MyFolderB	2007/01/12 14:45		
MyBMap0	2007/06/06 10:29		

4. Press F6 (Return). The copy destination file information is retained.



4. Edit file name (when creating new file)

1. (Skip this step when overwriting an existing file or copying to a folder) To edit the newly created file name, press F3 (Edit File Name On).

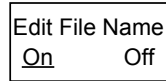

Note: You cannot change the names of files in the internal memory.

2. Move the cursor inside the character table using the Left/Right keys or Scroll knob. Press the Enter key to confirm each character and the BK SP key to delete one character.

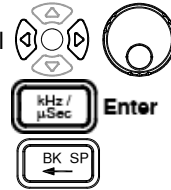

Char Table	
<u>A</u> B C D E F G H I J K L M N O P Q R S T U V W X Y Z a b c d e f	
g h i j k l m n o p q r s t u v w x y z 0 1 2 3 4 5 6 7 8 9	

3. When completed, press F3 (Edit File Name Off) to turn it off.

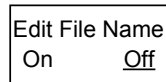

5. Copy file

1. Press F4 (Copy Now).

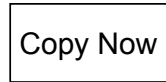

2. A confirmation message appears in the command window. To accept the file, press the Enter key. To cancel the file, press the BK SP key.

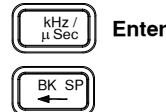

3. When the file copy is done, the destination file attribute changes from Empty to Full and/or the date becomes updated.

Destination			
Item	Name	Date	Remark
File Function: Copy Type: Trace Memory Internal			
	TraceA		
	TraceB		
	TraceC		
	Trace1	2007/07/09 10:41	Full

Note

If the source file does not contain data, a warning message appears. In this case, re-select a source file with actual data.

Selected File Is Empty!

Delete File

- 1. Connect USB flash drive (for external file)** When using the USB flash drive (external file) for source or destination, connect the drive to the front panel connector.



The USB icon turns on when the flash drive is detected.

- 2. Select source file** 1. Press the File key.



2. Press F2 (Delete).

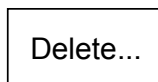

3. Press F1 (Type). The file deletion window appears.

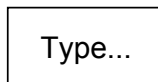

File Function:	Delete	Type:	Memory
Item	Name	Date	Remark

4. Select the file type by pressing F1 to F5, then select Int (internal) or Ext (external). The display gets updated accordingly. The example below shows the internal Trace files.

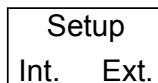
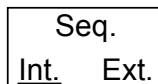
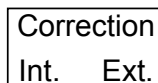
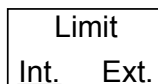
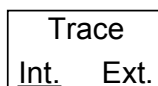

5. Use the Up/Down keys to move the cursor to the file location. (Example: internal Trace1 selected)



Item	Name	Date	Memory	Remark
	Trace1	2007/07/09 10:41	Internal	Full
	Trace2			Empty

6. Press F6 (Return). The file location is retained.

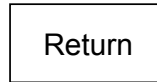

3. Delete file

1. Press F2 (Delete Now).



2. A confirmation message appears in the command window. To accept deletion, press the Enter key. To cancel deletion, press the BK SP key.

ENTER for Yes; BKSP for No:



Enter



3. Internal file: The file attribute (Remark) changes from Full to Empty.
External file: The file itself is deleted.

Item	Name	Date	Memory	Remark
	Trace1		Internal	Empty
	Trace2			Empty

Rename File

File rename is allowed only for external (USB flash drive) files.

- 1. Connect USB flash drive** Connect the USB flash drive to the front panel connector.



The USB icon turns on when the flash drive is detected.

2. Select file

1. Press the File key.



2. Press F3 (Rename). The USB flash drive contents and the character table appear in the display.

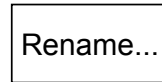

3. Point the cursor to the file using the Up/Down keys.



3. Edit file name

1. Press F1 (Edit File Name) and turn it on.

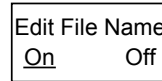

2. Move the cursor inside the character table using the Left/Right keys or Scroll knob. Press the Enter key to confirm each character.

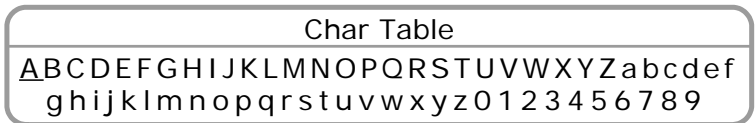
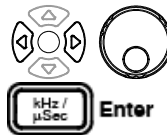

3. When completed, press F1 (Edit File Name Off) to turn it off.

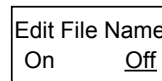

4. Press F2 (Confirm). A confirmation message appears in the command window.



ENTER for Yes: BKSP for No:

5. To accept renaming and save the new file name, press the Enter key. To cancel renaming, press the BK SP key.



Enter



Save Display Image to USB Flash Drive

- 1. Connect USB flash drive** Connect the USB flash drive to the front panel USB connector. The USB icon appears at the bottom of the display.



Compatibility USB 1.1/2.0

Connector TypeA host



Note

If it takes more than 2 seconds for the USB icon to appear, disconnect the USB flash drive and connect again.

2. Enter menu

1. Press the File key.



2. Press F4 (Print Screen).

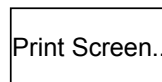

3. Press F1 (To Ext. Memory).

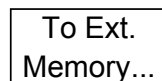

4. The USB flash drive contents appear in the display.

Item Name	Date	Remark
MyFolderA	2007/03/06 09:48	
MyFolderB	2007/01/12 14:45	
MyResultA	2007/06/06 10:29	

3. Selecting file

Move the cursor to the blank area using the Up/Down keys.



File Function: Print to File		Memory External
Item Name	Date	Remark
MyFolderA	2007/03/06 09: 48	
MyFolderB	2007/01/12 14: 45	
MyResultA	2007/06/06 10: 29	
MyBMap0		

To enter into an existing folder, move the cursor to the folder and press the **Enter** key.



Note

If the cursor is pointing to an existing file, the file will be overwritten.

4. Edit file name (when creating new file)

- (Skip this step when overwriting an existing file) To edit the newly created file name, press F1 (Edit File Name On).

Edit File Name
On Off

F 1

- Move the cursor inside the character table using the Left/Right keys or Scroll knob. Press the Enter key to confirm each character and the BK SP key to delete one character.

Enter

Char Table																															
<u>A</u>	B	C	D	E	F	G	H	I	J	K	L	M	N	O	P	Q	R	S	T	U	V	W	X	Y	Z	a	b	c	d	e	f
g	h	i	j	k	l	m	n	o	p	q	r	s	t	u	v	w	x	y	z	0	1	2	3	4	5	6	7	8	9		

- When completed, press F1 (Edit File Name Off) to turn it off.

Edit File Name
 On Off

F 1

5. Save file

- Press F2 (Print Now) and press F2 (Print Now).

Print Now



F 2

- A confirmation message appears in the command window. To accept the file, press the Enter key. To cancel the file, press the BK SP key.

ENTER for Yes; BKSP for No:

Enter

3. The file is saved when the date information appears. Now it is safe to remove the USB drive from the ISA830/ISA830TG.

File Function: Print to File		Memory External
Item Name	Date	Remark
 MyFolderA	2007/03/06 09:48	
 MyFolderB	2007/01/12 14:45	
MyResultA	2007/06/06 10:29	
MyBMap0	2007/07/10 15:30	

PRESET



Pressing the Preset key returns the ISA830/ISA830TG to the factory default parameters as defined below.

Frequency	Center: 1.5GHz Start: 0Hz	Stop: 3GHz Step: 1MHz
Span	3GHz	
Amplitude	Ref.level: 0dBm Unit: dBm Scale: 10dB/	External Gain: 0dB Input Z: 50Ω
Autoset	Amplitude Floor: Auto	Span: Auto
Marker	Marker: Off Marker Table: Off	Marker Trace: Auto All Marker: Off
Peak Search	Peak Table: Off Peak Threshold: Off	Peak Sort: Freq Peak Track: Off
Trace	Trace: A Average: Off, 20	Mode: Clear Detection: Normal
Meas	ACPR, OCBW: Off CH SPC: 0 CH BW: 600MHz OCBW %: 0	N dB, Phase Jitter: Off Adj CH Offs: 0MHz Adj CH BW: 0MHz
Limit Line	H & L Limit: Off	Pass/ Fail: Off
BW	RBW, VBW, Swptime: Auto	Average: Off, 20
Trigger	Trigger Delay: 50ms Trigger Mode: Normal	Trigger Freq: 1.5GHz
Display	LCD Dimmer: 5 Split Window: Off	Display Line: Off Display Title: Off
File	Copy Type: Int. Trace	Delete Type: Int. Trace
System	GPIB Add: 2 Aux Sig: Off	System Config: Off Clock: On
Option	External Ref Freq: 10MHz TG Norm Corr: Off	TG Output: Off TG Ref Value: 0dBm
Sequence	Sequence: 1	Run Mode: Single





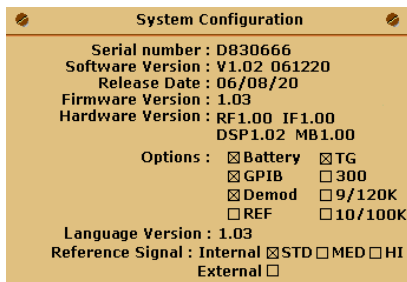
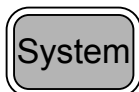



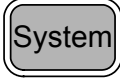

SYSTEM

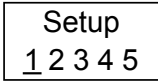
The **System key** configures and displays the system settings, including self-test result, date/time setting, and synchronization with other devices. The panel settings can be saved to ISA830/ISA830TG internal memories or external USB flash drive, the latter permitting transferring panel settings among multiple ISA830/ISA830TG.

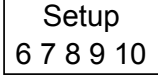

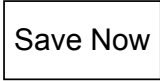

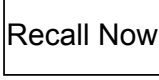
Panel Setting	Save/Recall Panel Setting	166
	Copy/delete/rename setup	166
Interface Configuration	USB slave port configuration	168
	RS-232C configuration	168
	GPIB	169
System Information	View system error	169
	View system configuration	171
	View self-test result	174
Date/Time	Set Date/Time	175
Synchronization	ISA830/ISA830TG as master (internal reference signal)	176
	ISA830/ISA830TG as slave (external reference signal)	177
Language	Select Language	178
Auxiliary Signal	Use Auxiliary Signal	179
Service Menu	Enter Service Operation	179

Save/Recall Panel Setting

Panel operation	1. Press the System key.	
	2. Press F1 (Save/Recall Setup).	 
	3. Press F1 or F2 repeatedly to select the setting file.	   
	4. Press F3 (Save Now) or F4 (Recall Now) to save or recall the setting file.	   

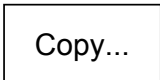

File contents	Setting file contains the following information. <ul style="list-style-type: none"> ● Reference amplitude level ● Amplitude unit, scale ● Start/stop frequencies ● Center and span frequencies ● VBW, RBW, and sweep time ● Tracking Generator level ● Tracking Generator normalization data
----------------------	---

Copy/delete/rename setup file

Background	Setting files can be copied, deleted, or renamed using the file utility. Press the File key to access each function.	
Copy	Press F1 (Copy). For detailed step, see page152.	 

Delete	Press F2 (Delete). For detailed step, see page157.	Delete...	F 2
Rename	Press F3 (Rename). For detailed step, see page159.	Rename...	F 3

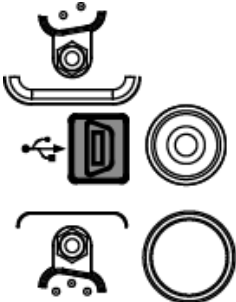
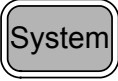
Configure Communication Interface

Background	The ISA830/ISA830TG supports two types of communication interfaces: standard USB and RS-232C.	
Communication Method	PC software (page192)	USB slave, RS-232C
	Remote control (page201)	USB slave, RS-232C
Interface type	USB slave	USB 1.1 or 2.0, TypeB mini
	RS-232C	D-sub 9 pin.
	GPIB (not supported)	IEEE-488 24pin.
USB slave port configuration	No need for panel configuration: Just connect a type B mini USB cable between the rear panel and PC.	
RS-232C configuration	1. The RS-232C configuration can be viewed from the system menu. Press the System key.	
	2. Press F3 (Serial Port).	 

3. The RS-232C port configuration appears. Configure the PC according to this setting.
 Baud: 57600
 Parity: None
 Stop bit: 1
 Data bit: 8

Baud 57600	F 1
Parity None	F 2
Stop 1	F 3
Data 8	F 4

4. Connect a 9-pin male RS-232C cable to the rear panel connector.

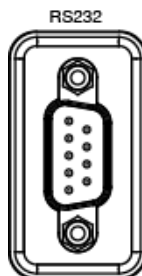

GPIB

The GPIB interface is not supported.

View System Information

View system error

Panel operation

View the bottom of the screen, the error message area. If there is a system error, the message appears in red.

Center : 1.5GHz EXT
Unlock (EXT Unlock)

**Amp
Uncal**

- Inappropriate RBW or VBW is selected.
- Frequency is less than 15MHz and amplitude is less than -30dBm.

**EXT
Unlock**

External reference input is not working properly.

**LO1
Unlock**

Local oscillator 1 is not working properly.

**LO3
Unlock**

Local oscillator 3 is not working properly.

**Ref
Unlock**

Internal reference signal is not working properly.

View system configuration

- Panel operation** 1. To check system configuration, press the System key.



2. Press F6 (More).

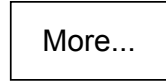

3. Press F4 (System Config On).

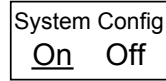

4. The system configuration appears. Four types of information are listed.

- Serial number
- Software/hardware/firmware/language version
- Installed optional items
- Reference signal selection status

System Configuration

Serial number : D830666
 Software Version : V1.02 061220
 Release Date : 06/08/20
 Firmware Version : 1.03
 Hardware Version : RF1.00 IF1.00
 DSP1.02 MB1.00

Options : Battery TG
 GPIB 300
 Demod 9/120K
 REF 10/100K

Language Version : 1.03

Reference Signal : Internal STD MED HI
 External

Serial Number

Software/
Hardware Version

Optional Item
Installation Status

Language Version

Reference Signal
Status

5. To close the configuration, press F4 again (System Config Off).

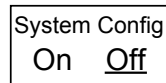

Serial number The serial number for device identification. This number is necessary for various service level operations. The same number is pasted on the rear panel.

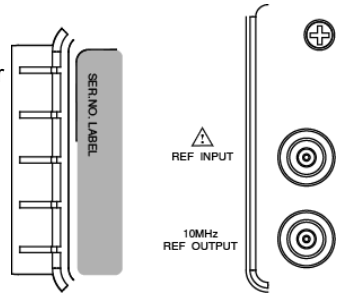

Software/hardware language version Shows versions and release date of hardware, software, firmware, and language database. Used for service level operations.

Optional item installation status Shows which optional item is currently installed.
: installed, : uninstalled.

Sign	Description
------	-------------

Battery	Not supported
----------------	---------------

GPIB	Not supported
-------------	---------------

Demod	Not supported
--------------	---------------

REF	Not supported
------------	---------------

300	Not supported
------------	---------------

9/120K	Not supported
---------------	---------------

10/100K	Not supported
----------------	---------------











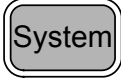
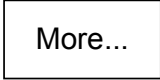

Reference signal status Checked radio button shows the reference signal used. For reference signal usage, see page 176.
: enabled, : disabled.

Sign	Description
------	-------------

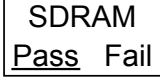
Internal STD	Internal reference signal, standard stability
Internal MED	Not supported.
Internal HI	Internal reference signal, high stability (reserved for future use). Not supported
External	External reference signal.

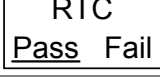
View self-test result

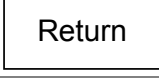
Background The ISA830/ISA830TG runs a series of internal tests upon power-up. If any of the test result shows Fail, contact the service center.

Panel operation	1. Press the System key.		
	2. Press F6 (More).		
	3. Press F2 (Self Test).		
	4. The result appears in F1 to F4.		
			
			
5. Press F6 (Return) to go back to the previous menu.			

Flash Internal Flash memory area for storing the system code and data.

SDRAM Internal SDRAM area on which the code runs.

RTC The real-time clock that controls the date and time settings (page175).

Set Date/Time

1. Activate clock display (if necessary) The clock display is activated by default.

1. Press the System key.

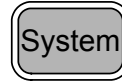

2. Press F6 (More).

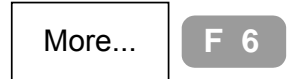

3. Press F1 (System Clock).



4. Press F3 (Clock On). The clock appears at the bottom right side of the display.

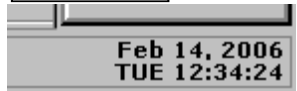

2. Set date

1. Press F1 (Date).



2. Press F1 (Year) to F4 (Day of Week). Enter the value using the Numerical keys and Enter key.



The clock display changes accordingly.



Year 2000 to 2099

Month 1 to 12 (translated to Jan to Dec)

Day 1 to 31 (depends on the month)

Day of Week 1(Mon) to 7(Sun)

3. Set time

1. Press F2 (Time).



2. Press F1 (Year) to F3 (Second). Enter the value using the Numerical keys and Enter key.

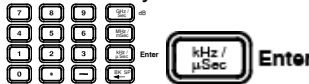

The clock display changes accordingly.

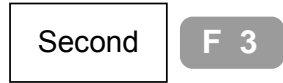

Hour 0 to 23

Minute 0 to 59

Second 0 to 59

Synchronize ISA830/ISA830TG with Other Devices

Using the REF INPUT/OUTPUT on the rear panel, the ISA830/ISA830TG can synchronize its internal frequency with other devices. The ISA830/ISA830TG can become the master (reference signal for another device) or the slave (reference signal input from another device).

ISA830/ISA830TG as master (internal reference signal)

Panel operation

Connect the reference signal output terminal on the rear panel to the other device's reference input.

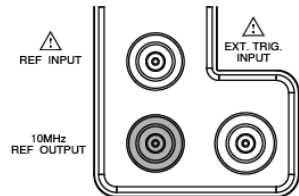

Signal type

Output level

10MHz, 5V TTL signal (assumes the load impedance is infinite)

Output impedance 50Ω

Stability check

1. Press the System key.

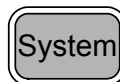

2. Press F6 (More).

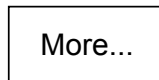

3. Press F4 (System Config On).

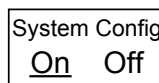

The system configuration window appears. The Internal Reference Signal sign **Internal** shows the status.
: enabled, : disabled.

STD

Internal reference signal, standard stability

MED

Internal reference signal, median stability. Not supported.



HI

Internal reference signal, high stability (reserved for future use). Not supported.

ISA830/ISA830TG as slave (external reference signal)

Panel operation

1. Press the Option key.



2. Press F4 (Ext Ref Freq) to enable external reference signal.

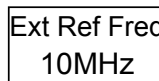

3. Use the Left/Right keys or Scroll knob to select the external reference frequency.



4. Connect the external reference signal to the input terminal on the rear panel.

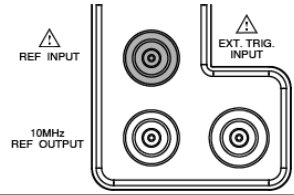

5. The external reference signal icon appears at the bottom of the display.



Signal type TTL signal

Frequency 10 preset frequencies are available (units in MHz).

1.0	1.544	2.048	5.0	10.0
10.24	13.0	15.36	15.4	19.2

- Status check** 1. Press the System key.

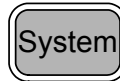

2. Press F6 (More).



3. Press F4 (System Config On).

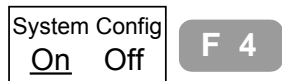

The system configuration window appears. The External Reference Signal sign **External** shows the status: - enabled, - disabled.

Select Language

- Panel operation** 1. Press the System key.

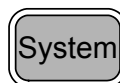

2. Press F6 (More).



3. Press F5 (Language).



4. Press F1 repeatedly to select the menu language.

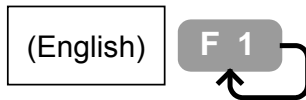

Language type English → Simplified Chinese → Other selections
(The language selection depends on the regions)

Use Auxiliary Signal

The auxiliary signal is a general purpose signal useful for functionality check.

- Panel operation** 1. Press the System key.

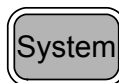

2. Press F4 (Aux Sig On). The auxiliary signal appears in the display.

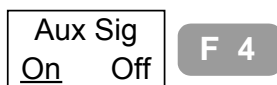

Specification 100MHz, -30dBm

Enter Service Operation

The following functions are intended only for service personnel.

- Optional items maintenance** 1. Press the System key.

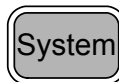

2. Press F5 (Service). To continue, a password is needed.

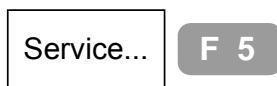

- RF diagnosis** 1. Press the System key.

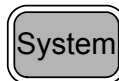

2. Press F6 (More).



3. Press F3 (RF Diagno). To continue, a password is needed.

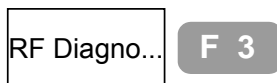

SEQUENCE

The **Sequence** function records and plays back user-defined macros (measurement steps). 10 sequences are available in repeat or single running mode, each with maximum 20 steps including all panel operations. Delay and pause features permit observing measurement results during the sequence.

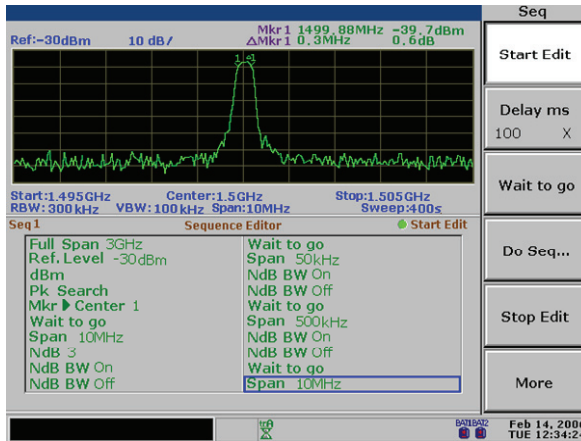

Edit	1. Select sequence	181
	2. Start editing	181
	3. Stop editing	185
	4. Save the edited sequence	185
	Delete all sequence	185
Run	1. Select sequence	186
	2. Select running mode	186
	3. Run sequence	187
Sequence File	Save/copy/delete/rename sequence file	187

Edit Sequence

1. Select sequence

1. Press the Sequence key. The display enters into the sequence edit mode.



2. Press F1 (sequence 1 to 5) or F2 (sequence 6 to 10) repeatedly to select the sequence ID.

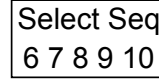
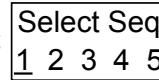

2. Start editing

1. Press F3 (Edit).

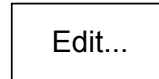

2. Press F1 (Start Edit).



3. The Start Edit sign in the mid-right of the display turns green.



2a. Add step

20 steps are available for each sequence. Every key operation can be recorded as a step.

Press the Enter key each time to confirm step entering. (In some cases this is not necessary: check if the item appears in the window).

Example: Activate system auxiliary signal

1. Press the System key.
2. Press F4 (Aux Sig On).
3. Press the Enter key.

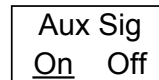
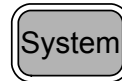

Example: Run Autose

1. Press the Autose key.
2. Press F1 (Autose).
3. Press the Enter key.



The result looks like this.



2b. Add delay

The delay function inserts a waiting period between steps. The basic unit of delay time is 100ms.

1. Press F2 (Delay ms).

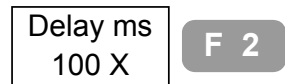

2. Enter the delay time using the Numerical keys and Enter key. For example, pressing 5 + Enter inserts 500ms (5 * 100ms) and pressing 100 + Enter inserts 10s (100 * 100ms = 10,000ms = 10s).



Range

100ms to 10s, 100ms resolution

2c. Pause sequence

Stops executing the sequence until the F1 (Continue) is pressed. Useful for observing the result of particular action (for example ACPR measurement).

1. Press F3 (Wait to go).

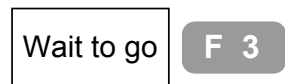

2. When the sequence is running, F1 (Continue) menu appears on the menu. Press it to break the pause and continue the sequence.

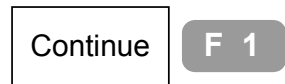

2d. Insert another sequence Inserts a whole sequence set.

1. Press F4 (Do Seq).

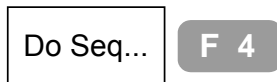

2. Press F1 (sequence 1 to 5) or F2 (sequence 6 to 10) repeatedly to select the inserted sequence.

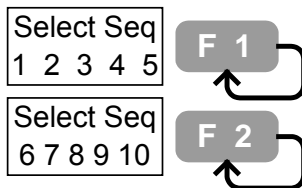

Note: The currently edited sequence cannot be inserted.

2e. Insert blank space

1. Press F6 (More).



2. Use the Up/Down keys to move the cursor to the insertion point.



3. Press F1 (Insert). A blank space will be created.

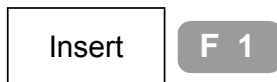

Aux Sig On
Autoset
Delay ms 5s
NdB BW On
NdB 5

Aux Sig On
Autoset
Delay ms 5s
NdB BW On
NdB 5



4. Press F6 (Return) to go back to the previous menu.

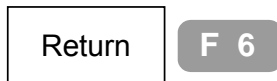

2f. Delete step

1. Press F6 (More).



2. Use the Up/Down keys to move the cursor to the deletion point.



3. Press F3 (Delete). The step will be deleted.

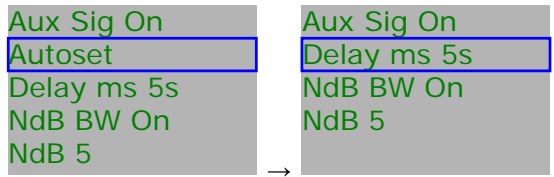

4. To undo deletion, press F5 (Undelete).



5. To go back to the previous menu, press F6 (Return).



2g. Delete all steps in a sequence

1. Press F6 (More).



2. Press F4 (Delete All).

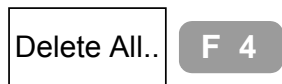

3. Press F2 (Yes) to confirm, or F1 (No) to cancel. All steps will be deleted.



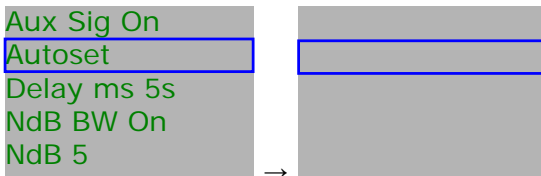

4. To undo deletion, press F5 (Undelete).

Undelete

F 5

5. Press F6 (Return) to go back to the previous menu.

Return

F 6

3. Stop editing

1. Press F5 (Stop Edit).

Stop Edit

F 5

2. The Start Edit sign in the display mid-right turns off.



4. Save the edited sequence

1. Press F6 (More).

More

F 6

2. Press F2 (Save). The sequence is saved.

Save

F 2

3. Press F6 (Return) to go back to the previous menu.

Return

F 6

Delete all sequences

- Panel operation** 1. Press the Sequence key.



2. Press F5 (Delete Seq All).

Delete
Seq All...

F 5







- | | | | |
|----|--|--------|-----|
| 3. | Press F2 (Yes) to confirm, or F1 (No) to cancel. All 10 sequences will be deleted. | No | F 1 |
| | | Yes | F 2 |
| 4. | To go back to the previous menu, press F6 (Return). | Return | F 6 |

Note Delete Seq All cannot be recovered – the Undelete function is not applicable.

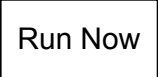





Run Sequence

This section assumes that editing the sequence is completed.

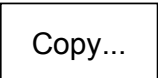
- | | | | | | | | | | |
|-------------------------------|---------------|--|--|-------------------------|-----|---|--------------------------|-----|---|
| 1. Select sequence | 1. | Press the Sequence key | Seq | | | | | | |
| | 2. | Press F1 (sequence 1 to 5) or F2 (sequence 6 to 10) repeatedly to select the sequence. | <table border="0"> <tr> <td style="border: 1px solid black; padding: 5px;">Select Seq
1 2 3 4 5</td> <td style="border: 1px solid gray; border-radius: 10px; padding: 5px; text-align: center; background-color: #cccccc;">F 1</td> <td style="font-size: 2em;">↶</td> </tr> <tr> <td style="border: 1px solid black; padding: 5px;">Select Seq
6 7 8 9 10</td> <td style="border: 1px solid gray; border-radius: 10px; padding: 5px; text-align: center; background-color: #cccccc;">F 2</td> <td style="font-size: 2em;">↶</td> </tr> </table> | Select Seq
1 2 3 4 5 | F 1 | ↶ | Select Seq
6 7 8 9 10 | F 2 | ↶ |
| Select Seq
1 2 3 4 5 | F 1 | ↶ | | | | | | | |
| Select Seq
6 7 8 9 10 | F 2 | ↶ | | | | | | | |
| 2. Select running mode | 1. | Press F4 (Run). | Run... | F 4 | | | | | |
| | 2. | Press F1 (Run Mode) to select the running mode, repeat (Rept) or single (Sngl). | Run Mode
Rept Sngl | F 1 | | | | | |
| | Repeat | Repeats running a sequence until F6 (Stop) is pressed. Note: F6 (Stop) menu appears only when the sequence is running. | | | | | | | |
| | Single | Runs the sequence once. | | | | | | | |

3. Run sequence	1. Press F2 (Run Now).		
	2. If the sequence editing has not yet finished, a warning message appears. In such case, stop (finish) the editing process first (page185).		
	3. The sequence icon appears at the bottom of the display.		
	4. To stop running, press F6 (Stop). In the single mode, the sequence automatically stops when all steps are completed.		

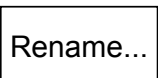
Save/copy/delete/rename sequence file

Background	Sequence files can be saved, copied, deleted, or renamed using the file utility. Press the File key to access each function.		
Save/Copy	Press F1 (Copy). For detailed steps, see page152.		
Delete	Press F2 (Delete). For detailed steps, see page157.		
Rename	Press F3 (Rename). For detailed steps, see page159.		

TRACKING GENERATOR (ISA830TG)

The optional **Tracking Generator** (for ISA830TG only) (Opt.01) is a factory installed item which generates a sweep signal with its sweep time and frequency range matching the ISA830TG system. The amplitude is maintained to a constant value over the entire frequency range, which is very useful for testing the frequency response of the DUT.



Activate tracking generator

1. Activate TG output

1. Press the Option key.



2. Press F1 (TG).



3. Press F1 (TG On).

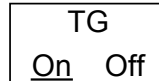

4. The tracking generator output becomes activated.

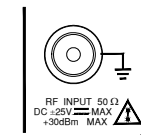

2. Set TG output level

1. Press F2 (TG Level).













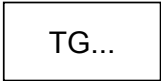

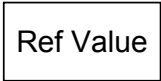

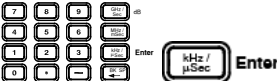
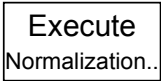
2. Change the TG output level using the Numerical keys and Enter key.

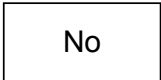

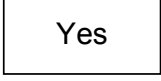

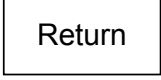



Range

0 to -50dBm

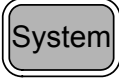
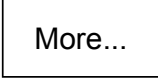
Normalize tracking generator

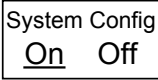
1. Set reference level	1. Press the Option key.	
	2. Press F1 (TG).	 
	3. Press F5 (Ref Value).	 
	4. Set the reference value using the Numerical keys and Enter key.	
<p>Normalization amplitude is set at Reference level regardless of the TG output level.</p> <p>Range -130dBm to +20dBm</p>		
2. Run normalization	1. Press F3 (Execute Normalization).	 
	2. Press F2 (Yes) to confirm running Normalization. Press F1 (No) to cancel running.	 
		 
3. Press F6 (Return) to go back to the previous menu.	 	
3. Activate normalization	1. To activate normalization, press F4 (Norm Corr On).	 
	2. Normalization is activated and the TG icon appears.	

Check TG installation status

Panel operation	1. Press the System key.	
	2. Press F6 (More).	 
	3. Press F4 (System Config On). The configuration appears.	 
	4. The TG sign shows the installation status, installed (checked) or not installed (unchecked).	Installed  Not installed 

DC Operation

Panel operation A DC power cable can be connected to the rear panel input connector.



Specification 12V, 40W max, 2.1mm plug



Note The DC power option is not supported.

PC SOFTWARE

The Eagleshot software permits waveform viewing and major panel operations using the familiar PC interface: large monitor, keyboard, and mouse.

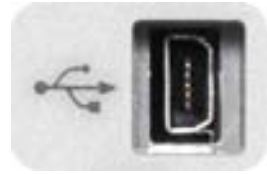
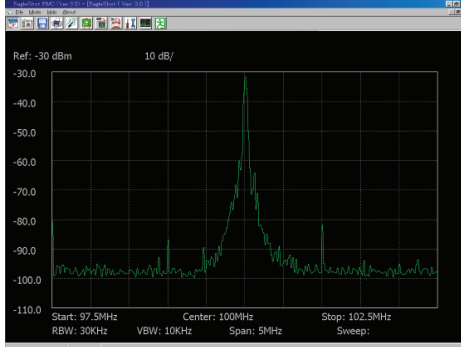

Installation	PC requirement.....	193
	Installation step	193
Invocation	Configure interface	194
	Invoke software	195
Usage	Establish connection	197
	Capture waveform.....	197
	Clear waveform.....	198
	Save waveform	198
	Printout screen image	198
	Use marker.....	198
	Exit program	200

Install Software

PC requirement

Software	OS	Windows 2000/XP
Hardware	USB	1 USB host connector, 1.1 or 2.0 compatible

Installation step

- 1. Activate setup software**
 1. Unpack the zip file.
 2. Double click Setup.exe.
 3. The setup screen opens. Close all other applications and click OK. To cancel, click Exit Setup.

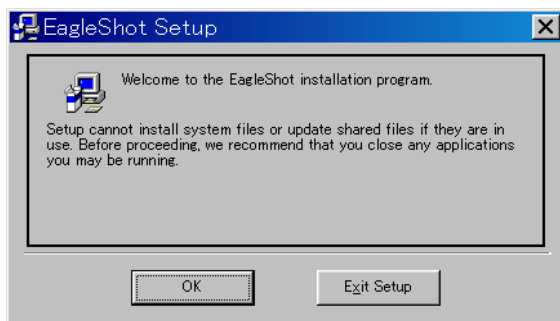

2. Start installation

1. To install the software into a specific directory, click the Change Directory button.

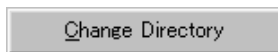

2. Click the icon to start installation.



3. When the installation is successful, a message appears. Click OK to complete the installation.

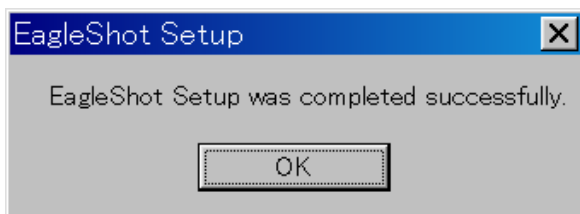

Connect Software

This section assumes that the software is already installed.

Configure interface

USB slave or RS-232C is acceptable.

Configure USB No need to configure anything on the ISA830/ISA830TG side. Just connect the type B mini USB cable to the rear panel.

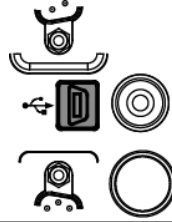

Configure RS-232C

1. The RS-232C configuration can be checked from the system menu. Press the System key.



2. Press F3 (Serial Port).



3. The RS-232C port configuration appears. Configure the PC according to this setting.
 Baud: 57600
 Parity: None
 Stop bit: 1
 Data bit: 8

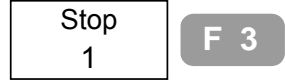
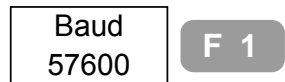

4. Connect a 9 pin, male RS-232C cable to the rear panel connector.

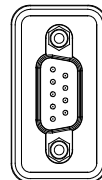

Invoke software

- PC operation** 1. Invoke the software from the startup menu in the PC.

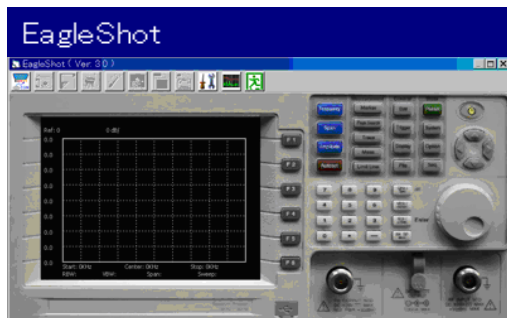

2. Click the setting icon. The parameter setting window appears.

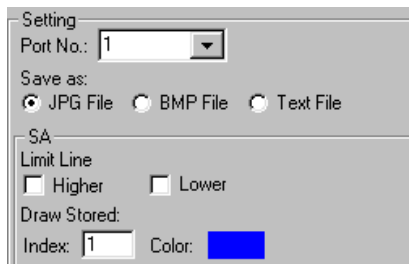

3. Select the connection port (COM port).

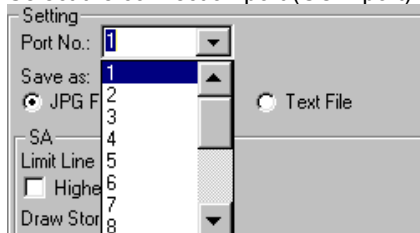

To check the configuration in the PC, go to Control panel → System properties → Device Manager.

4. Click the Setting icon again to close the setting window



5. Click the Open COM Port icon. The connection is established when the other icons become active.



Functionality check

Click the Capture icon. Make sure the waveform shown in the ISA830/ISA830TG display is captured correctly.

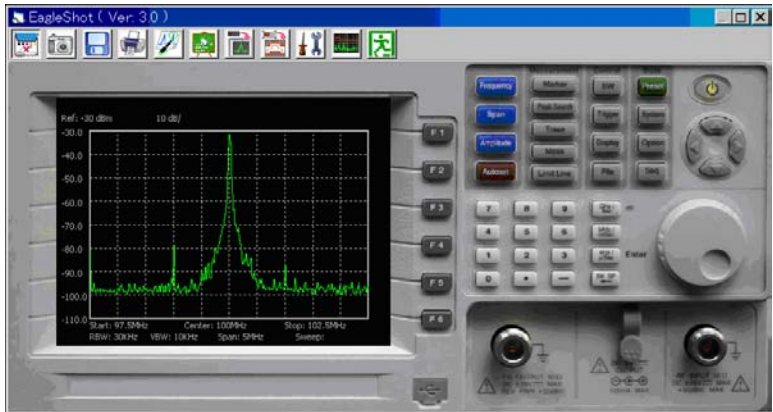

Use Software

Establish connection

Operation step 1. Press the setting icon and open the parameter setting window.



2. Select the serial port terminal.

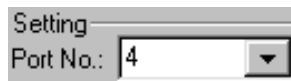

3. Press the COM port icon. The connection is established when the other icons become active.



Port setting

Select the port specified in the PC configuration. To check the configuration in the PC, go to Control panel → System properties → Hardware tab → Device Manager.

Capture waveform

Operation step Click the capture icon. The current waveform is captured and appears on the screen.



Display

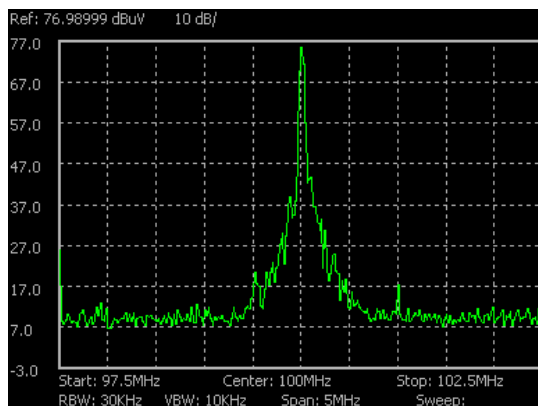

Clear waveform

- Operation step** Click the clear trace icon. The waveform is cleared from the screen.



Save waveform

- Operation step** 1. Press the setting icon. Select the file format from *.jpg/*.bmp (screen snapshot), *.txt (measurement data).



2. Press the save icon. The standard save dialogue window opens. Select the directory and save the file.



File format The *.txt file contains the following information.

- Frequency (MHz) and Amplitude for all waveforms
- Amplitude reference level, unit, and scale
- Start, Stop, Center frequency, and frequency span
- RBW, VBW, and sweep time
- Date and time (if already configured)

Printout screen image

- Operation step** Click the print icon. The standard printout dialogue opens. Select the printer and printout the screen image.



Note The screen image contrast will be reversed (background color becomes white).

Use marker

- Operation step** 1. Click the marker icon. The marker function window appears.



Marker Function

Live Storage

	Freq(MHz)	Delta
<input checked="" type="checkbox"/> 0	99	
<input checked="" type="checkbox"/> 1	100	0
<input type="checkbox"/> 2	0	N
<input type="checkbox"/> 3	0	N
<input type="checkbox"/> 4	0	N

2. Select Live or Storage.

Live Storage

3. Check the marker ID box. 5 markers, 0 to 4, are available.

0
 1

4. Enter the frequency to each marker in MHz.

Freq(MHz)

99

100

5. Select normal (N) or delta marker.
Example:
Marker 0 & Delta 1: the delta marker shows the difference between marker0 and marker1.

Delta



0

N

6. The display is updated with markers in red color. The marker values are listed at the bottom of the display.

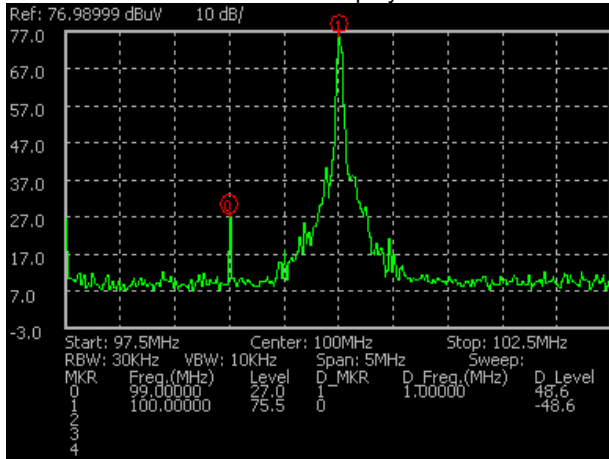

Exit program

Operation step Click the exit icon or press Alt key + F4.









REMOTE CONTROL

The ISA830/ISA830TG supports remote control which is partially based on IEEE 488.2 and SCPI (Standard Commands for Programmable Instrumentation) standards. The command set covers most of the panel operations. Three interfaces are available: USB slave and RS-232. GPIB is not supported.

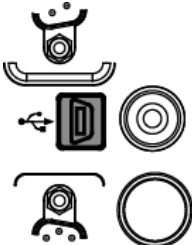
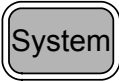
Interface	Configure Interface 203
Command Syntax	Command Syntax..... 204
Status Registers	Status Registers 206
Command Set	IEEE488.2 standard commands 210
	Register commands 210
	Sweep commands..... 210
	Frequency 211
	Span 211
	Amplitude 211
	Autoset 212
	Marker & Peak Search 213
	Trace 214
	Power measurement 215
	Limit line 216
	BW 217
	Trigger 218
	Display..... 218
	File 219
	Preset 219

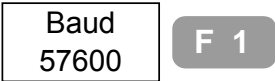
	System	219
	Option.....	220
	Sequence.....	221

Configure Interface

Interface type	USB slave	USB 1.1 or 2.0, type B mini
	RS-232C	D-sub 9 pin
	GPIB (not supported)	24 pin
USB slave port configuration	<p>No need for panel configuration: Just connect a type B mini USB cable to the rear panel.</p>  <p>The USB icon turns on when the connection is detected.</p> 	
RS-232C configuration	<p>1. The RS-232C configuration can be checked from the system menu. Press the System key.</p> 	
	<p>2. Press F3 (Serial Port).</p> 	
	<p>3. The RS-232C port configuration appears. Configure the PC according to this setting.</p> <p>Baud: 57600</p> <p>Parity: None</p> <p>Stop bit: 1</p> <p>Data bit: 8</p>    	

4. Connect a 9-pin male RS-232C cable to the rear panel terminal.

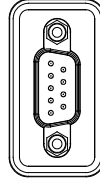

Functionality Check

Run this query command from the terminal.

*idn?

This should return the instrument type.

3GHz Spectrum Analyzer

Command Syntax

The commands are partially compatible with IEEE488.2 (1992) and SCPI (Standard Commands for Programmable Instrumentation) (1994) standards. Commands are NON-case sensitive.

Example command

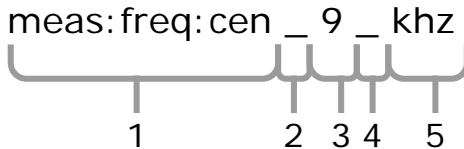

1: Command Header

2: Single space

3: Parameter1

4: Single space

5: Parameter2

Command Header

Several command header elements (nodes) can be concatenated to form a complex command.

The above example can be separated into:

meas: (root node) + freq: + cen:

Parameter example

0/1 0 or 1.

1to4 Integer between 1, 2, 3, or 4.

0.01to5 Decimal number between 0.01 and 5.

khz Unit (non-case sensitive)

Message Terminator

Marks the end of a command line. Any of the following is acceptable.

CR^END Line feed code (hexadecimal 0D) with END message

	CR	Line feed code
	<dab>^END	Last data byte with END message
Message Separator	; (semicolon)	Command separator.

Status Registers

To program the ISA830/ISA830TG effectively, the Status Register structure needs to be understood. This chapter explains in detail the structure of the status registers.

Description

The status registers are used to determine the status of the spectrum analyzer. The status registers maintain the status of the operation events, execution errors, messages and service requests.

The ISA830/ISA830TG has a number of registers:

- Operation Event Status Register
- Operation Event Status Enable Register
- Standard Event Status Register
- Standard Event Status Enable Register
- Status Byte Register
- Service Request Enable Register

The structure of the status registers is shown on the next page.

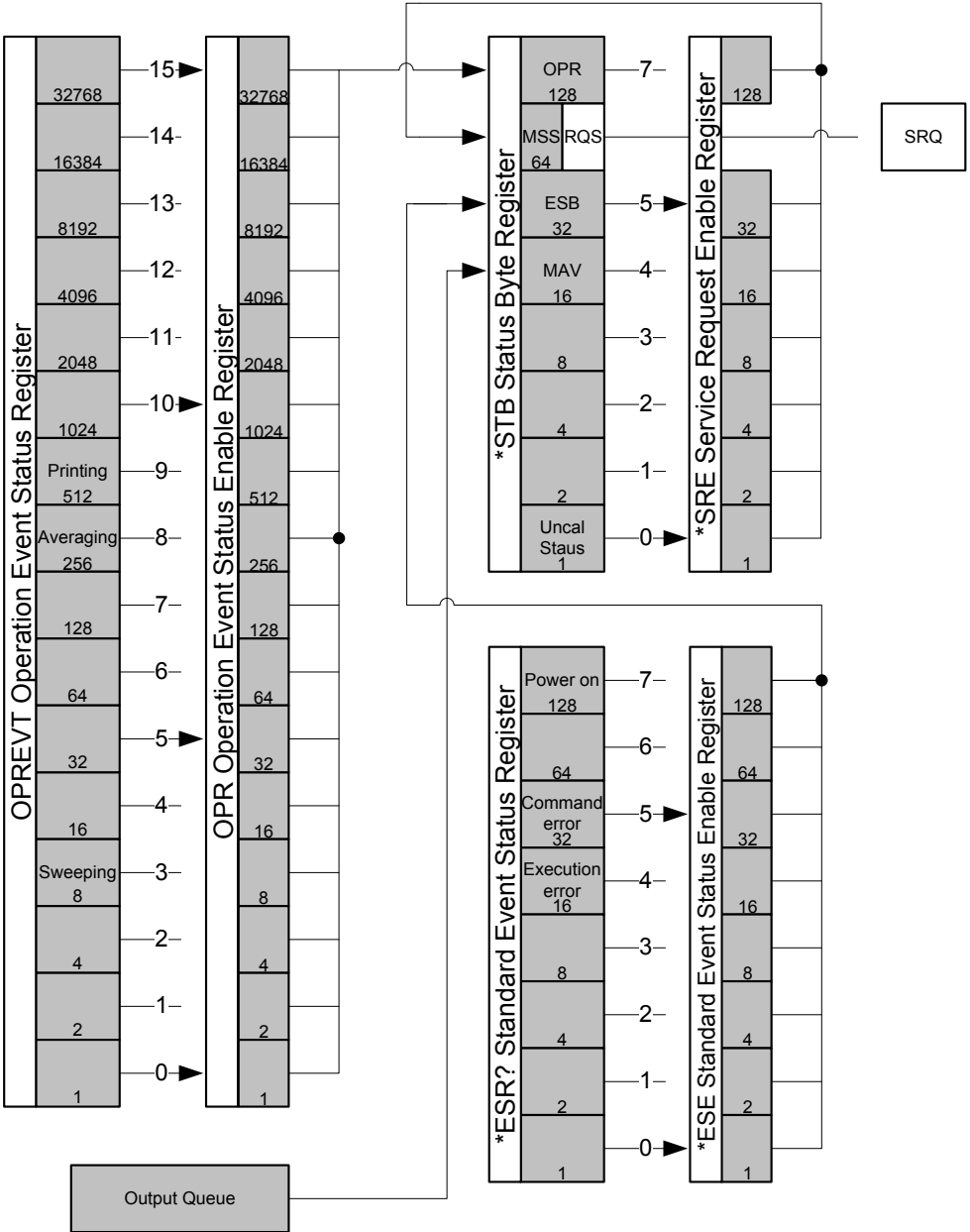

Operation Event Status Register The Operation Event Status Register is used to indicate if events have been completed.

Operation Event Status Register

Bit	Event	Description
0 to 2		Not used.
3	Sweeping	This bit is set to 1 when a sweep has been completed.
4 to 7		Not used.
8	Averaging	This bit is set to 1 when Averaging has been completed.
9	Printing	This bit is set to 1 when saving the display image to an external USB flash drive has completed.
10 to 15		Not used.

Operation Event Status Enable Register The Operation Event Status Enable Register is used to determine which events in the Operation Event Status Register will set the OPR bit in the Status Byte Register.

Standard Event Status Register The Standard Event Status Register is used to indicate if any standard events have occurred.

Standard Event Status Register

Bit	Event	Description
0 to 3		Not used.
4	Execution	This bit is set to 1 when the program data is out of range.
5	Command Error	This bit is set to 1 when an illegal command is used.
6		Not used.
7	Power On	

Standard Event Status Enable Register The Standard Event Status Enable Register is used to determine which events in the Standard Event Status Register will set the ESB bit in the Status Byte Register.

Status Byte Register The Status Byte Register is used to summarize the events from the Operation Event Status Enable Register and the Standard Event Status Enable Registers as well as indicate service requests and message requests.

Status Byte Register

Bit	Event	Description
0	Uncal status	This bit is set to 1 when the sweep is too fast resulting in an unstable signal.
1 to 3		Not used.
4	MAV	The MAV (Message AVailable) bit is set when there is a data in the Output Queue.
5	ESB	The ESB (Event Summary Bit) bit is set when any of the events are set and enabled in the Standard Event registers.
6	MSS/RQS	The MSS/RQS bit is used for service requests. MSS: The MSS bit is essentially a summary of all the events for all the status registers. The MSS bit is set when any events in the Service Request Enable Register are set. RQS: The RQS bit is set when the MSS bit is set. The RQS bit indicates that there is at least one reason for a service request.
7	OPR	The outputs from the Operation Event Status Enable Register (OPR) are logically ORed to summarize the OPR event (bit 7) in the Status Byte Register. Thus the corresponding bits in the OPR register must be enabled first before the OPR event can be set.

Command Set

- Commands are **non**-case sensitive.
- Underline means a single space (100_mhz→100 mhz).

IEEE488.2 standard commands

*cls	Clear Status Command.
*ese?	Standard Event Status Enable Register Query.
*ese	Standard Event Status Enable Register Command. Parameter: 1 to 255. Example: *ESE_128 (Set bit 7)
*esr?	Standard Event Status Register Query.
*idn?	Identification Query. Parameter: Instrument type. Example: 3GHz Spectrum Analyzer
*rst	Reset Command.
*sre?	Service Request Enable Register Query.
*sre	Service Request Enable Register Command. Parameter: 1 to 255. Example: *SRE_128 (Set bit 7)
*stb?	Read Status Byte Register Query.
*tst?	Self-Test Query.

Register commands

opr	Operation Event Status Enable Register command. Sets which events in the Standard Operation Status Register can be enabled. Parameter: 1 to 65535. Example: OPR_8
opr?	Operation Event Status Enable Register query. Queries which events in the Standard Operation Status Register are enabled. Returns the bit weight of the Operation Event Status Enable Register. Return parameter: 1 to 65535. Example: 8 (bit 3 is set.)
oprevt?	Operation Event Status Register query. Returns the bit weight of the Operation Event Status Register. Return parameter: 1 to 65535. Example: 8 (bit 3 is set.)

Sweep commands

si	Stop the sweep.
ts	Reset the sweep and start once.
sn	Continue the sweep.

Frequency

meas:freq:cen?	Returns the center frequency in kHz. Example: 1000000 khz
meas:freq:cen	Sets the center frequency. Example: meas:freq:cen_100_mhz
meas:freq:st?	Returns the start frequency in kHz. Example: 1000000 khz
meas:freq:st	Sets the start frequency. Example: meas:freq:st_100_mhz
meas:freq:stp?	Returns the stop frequency in kHz. Example: 1000000 khz
meas:freq:stp	Sets the stop frequency. Example: meas:freq:stp_100_mhz
meas:freq:ss?	Returns the frequency step size in kHz. Example: 1000000 khz
meas:freq:ss	Sets the frequency step. Example: meas:freq:ss_100_mhz
meas:freq:cen:fw	Moves the center frequency one step size forward.
meas:freq:cen:bw	Moves the center frequency one step size backward.

Span

meas:span?	Returns the frequency span in kHz. Example: 10000 khz
meas:span	Sets the frequency span. Example: meas:span_10_mhz
meas:span:full	Sets the frequency span to full.
meas:span:zero	Sets the frequency span to zero.
meas:span:last	Recalls the last frequency span setting.

Amplitude

meas:refl:unit?	Returns the reference level unit. Parameter: 1 (dBm), 2 (dBmV), 3 (dBuV)
meas:refl:unit	Sets the reference level unit. Parameter: 1 (dBm), 2 (dBmV), 3 (dBuV) Example: meas:refl:unit_1 (dBm)
meas:refl?	Returns the reference level in the current unit. Example: -30 (-30dBm when the unit is dBm)
meas:refl	Sets the reference level in the current unit. Example: meas:refl_-30 (-30dBm when in dBm)
meas:refl:scale?	Returns the amplitude scale. Parameter: 1(10dB/Div), 2(5dB/Div), 3(2dB/Div), 4(1dB/Div)
meas:refl:scale	Sets the amplitude scale. Parameter: 1(10dB/Div), 2(5dB/Div), 3(2dB/Div), 4(1dB/Div) Example: meas:refl:scale_1 (10dB/Div)
meas:refl:exg?	Returns the external gain/loss in dB. Example: -6 (-6dB)
meas:refl:exg	Sets the external gain/loss. Example: meas:refl:exg_-6 (-6dB)

meas:refl:corr:edit	Sets the amplitude correction data (frequency, amplitude). Need to specify the table index and the number of correction. Example: meas:refl:corr:edit_1_CR_2,100,-40,150,-30, (table index1, 2 data, 100MHz/~40dB, 150MHz/~30dB)
meas:refl:corr:edit:delall	Deletes all point in an amplitude correction set. Need to specify set index. Example: meas:refl:corr:edit:delall_5 (delete set No.5)
meas:refl:corr:on?	Returns the activated amplitude correction set. Parameter: none, 1 to 5 (correction set)
meas:refl:corr:on?	Returns the amplitude correction set is active or inactive. Need to specify the set index. Parameter: on, off Example: meas:refl:corr:on_1? (set No.1 is activated?)
meas:refl:corr:on	Activates the amplitude correction set. Specify the set index. Example: meas:refl:corr:on_1 (activate set No.1)
meas:refl:corr:off	Deactivates the amplitude correction set. Specify set index. Example: meas:refl:corr:off_1 (deactivate set No.1)
meas:inputz?	Returns the input impedance. Parameter: 0 (50 Ω), 1 (75 Ω)
meas:inputz	Sets the input impedance. Parameter: 0 (50 Ω), 1 (75 Ω) Example: meas:inputz_0 (50Ω)
meas:inputz:cal?	Returns the input impedance calibration value in dB.
meas:inputz:cal	Sets the input impedance calibration value in dB. Example: meas:inputz:cal_5.9 (5.9dB)

Autoset

meas:autoset:run	Runs autoset.
meas:autoset:amp:auto	Sets the autoset amplitude floor setting to auto mode.
meas:autoset:amp:man	Sets the autoset amplitude floor setting to manual mode. Need to specify the amplitude in the current unit. Example: meas:autoset:amp:man_20 (20dB)
meas:autoset:amp:mode?	Returns the autoset amplitude floor setting mode. Parameter: auto, manual
meas:autoset:span:auto	Sets the autoset frequency span setting to auto mode.
meas:autoset:span:man	Sets the autoset frequency span setting to manual mode. Need to specify unit. Example: meas:autoset:span:man_100_khz (100kHz)
meas:autoset:span:mode?	Returns the autoset frequency span setting mode. Parameter: auto, manual

Marker & Peak Search

meas:mark:on?	Returns marker On/Off. Need to specify the marker ID. Parameter: on, off Example: meas:mark:on_1? (marker1 On?)
meas:mark:on	Turn On marker. Parameter: 1to5 (marker ID), all (all markers) Example: meas:mark:on_1 (marker 1 On)
meas:mark:off	Turn Off marker. Parameter: 1 to 5 (marker ID), all (all markers) Example: meas:mark:off_1 (marker 1 Off)
meas:mark:norm	Sets a marker to normal mode. Parameter: 1 to 5 (marker ID) Example: meas:mark:norm_1 (marker 1 normal mode)
meas:mark:norm:freq?	Returns the frequency of a normal marker. Need to specify ID. Example: meas:mark:norm:freq_1? (normal mkr1 frequency?)
meas:mark:norm:level?	Returns the amplitude of a normal marker. Need to specify ID. Example: meas:mark:norm:level_1? (normal mkr1 level?)
meas:mark:delta	Sets a marker to delta mode. Also sets the relative frequency. Parameter: 1 to 5 (marker ID) Example: meas:mark:delta_1_10_mhz (marker 1 in delta mode, relative frequency 10MHz)
meas:mark:delta:freq?	Returns the relative frequency of a delta mkr. Need to specify ID. Example: meas:mark:delta:freq_1?(delta mkr1 freq?)
meas:mark:delta:level?	Returns the relative amplitude of a delta mkr. Need to specify ID. Example: meas:mark:delta:level_1?(delta mkr1 amp?)
meas:mark:tomin	Moves a marker to minimum peak. Parameter: 1 to 5 (marker ID) Example: meas:mark:tomin_1 (marker 1 to min peak)
meas:mark:topeak	Moves a marker to the peak. Parameter: 1 to 5 (marker ID) Example: meas:mark:topeak_1 (marker 1 to peak)
meas:mark:tonp	Moves a normal/delta marker to the next peak. Parameter: 1 to 5 (marker ID) Example: meas:mark:tonp_1 (marker 1 to the next peak)
meas:mark:tonpr	Moves a normal/delta marker to the next right peak. Parameter: 1 to 5 (marker ID) Example: meas:mark:tonpr_1 (marker 1 to the next right pk)
meas:mark:tonpl	Moves a normal/delta marker to the next left peak. Parameter: 1 to 5 (marker ID) Example: meas:mark:tonpl_1 (marker 1 to the next left peak)
meas:mark:tocen	Moves a normal/delta marker to the center frequency. Parameter: 1 to 5 (marker ID) Example: meas:mark:tocen_1 (marker 1 to the center freq)
meas:mark:tost	Moves a normal/delta marker to the start frequency. Parameter: 1 to 5 (marker ID) Example: meas:mark:tost_1 (marker 1 to the start frequency)

meas:mark:tostp	Moves a normal/delta marker to the stop frequency. Parameter: 1 to 5 (marker ID) Example: meas:mark:tostp_1 (marker 1 to stop frequency)
meas:mark:toss	Moves a normal/delta marker to the stop frequency. Parameter: 1 to 5 (marker ID) Example: meas:mark:toss_1
meas:mark:torefl	Moves a normal/delta marker to the reference level. Parameter: 1 to 5 (marker ID) Example: meas:mark:torefl_1 (marker 1 to the reference level)
meas:mark:trace	Moves a normal/delta marker to a trace. Parameter: 1 to 5 (marker ID), followed by 0 (auto), 1 (traceA), 2 (traceB), 3 (traceC) Example: meas:mark:trace_1_2 (marker 1 to traceB)
meas:mark:marktable:on	Activates marker table.
meas:mark:marktable:off	Deactivates marker table.
meas:mark:peaktable:on	Activates peak table.
meas:mark:peaktable:off	Deactivates peak table.
meas:mark:peaktable:sortf	Sorts peak table by frequency.
meas:mark:peaktable:sorta	Sorts peak table by amplitude.
meas:mark:peaktrack:on	Turns On peak track. Parameter: 1 to 5 (marker ID) Example: meas:mark:peaktrack:on_1(marker1 track on)
meas:mark:peaktrack:off	Turns Off peak track. Parameter: 1 to 5 (marker ID) Example: meas:mark:peaktrack:off_1(marker1 track off)
meas:mark:peakthres:on	Turns On peak threshold and sets amplitude. Parameter: peak threshold in dB. Example: meas:mark:peakthres:on_-30 (-30dB threshold)
meas:mark:peakthres:off	Turns Off peak threshold.

Trace

meas:tra	Sets the mode for a trace. Parameter: 1 (traceA), 2 (traceB), 3 (traceC), followed by 1(clear), 2(peak hold), 3(view), 4(blank), 5(mini_hold) Example: meas:tra_1_2 (traceA set to peak hold mode)
meas:tra:avg:on	Turns On average mode and sets average number for a trace. Parameter: 1(traceA), 2(traceB), 3(traceC), followed by No. Example: meas:tra:avg:on_1_20 (Average trace A 20 times)
meas:tra:avg:off	Turns Off the average mode. Parameter: 1 (traceA), 2 (traceB), 3 (traceC) Example: meas:tra:avg:off_1 (traceA average mode Off)

meas:tra:read?	Returns trace data. Parameter: 1(traceA), 2(traceB), 3(traceC), all(all three traces) Example: meas:tra:read_1? (traceA data)
meas:tra:a<>b	Swaps trace A and B.
meas:tra:a+b>a	Adds trace B to A.
meas:tra:a-b>a	Subtracts trace B from A.
meas:tra:const?	Returns the constant value to be added or subtracted.
meas:tra:const	Sets the constant value to be added or subtracted. Example: meas:tra:const 6
meas:tra:a+const>a	Adds a constant value to traceA.
meas:tra:a-const>a	Subtracts a constant value from traceA.
meas:tra:det?	Returns the detection mode. Parameter: 1(normal), 2(sample), 3(peak+), 4(avg), 5(qpeak)
meas:tra:det	Sets the detection mode. Parameter: 1(normal), 2(sample), 3(peak+), 4(avg), 5(qpeak) Example: meas:tra:det_4 (set the detection mode to average)

Power measurement

meas:ch:bw?	Returns the main channel bandwidth in kHz. Example: 1000 khz
meas:ch:bw	Sets the main channel bandwidth. Need to specify the unit. Example: meas:ch:bw_1_mhz (1MHz)
meas:adjch:bw?	Returns the adjacent channel bandwidth in kHz. Need to specify the channel. Example: meas:adjch:bw_2? (adjacent channel2 bandwidth)
meas:adjch:bw	Sets the adjacent channel bandwidth. Need to specify CH and unit. Example: meas:adjch:bw_2_1_mhz(adj CH2 BW 1MHz)
meas:adjch:offs?	Returns the adjacent channel offset in kHz. Specify channel. Example: meas:adjch:offs_2? (adjacent channel2 offset)
meas:adjch:offs	Sets the adjacent channel offset. Specify channel and unit. Example: meas:adjch:offs_2_1_mhz (adjacent ch2 offs 1MHz)
meas:acpr?	Returns ACPR activation status. Parameter: on, off
meas:acpr	Turns On/Off ACPR measurement. Parameter: on, off Example: meas:acpr_on (ACPR On)
meas:acpr:lower?	Returns the lower ACPR result. Need to specify 1 or 2. Example: meas:acpr:lower_2? (lower ACPR 2 result?)
meas:acpr:upper?	Returns the upper ACPR result. Need to specify 1 or 2. Example: meas:acpr:upper_2? (upper ACPR 2 result?)
meas:acpr:chup	Moves the ACPR channel up.
meas:acpr:chdown	Moves the ACPR channel down.

meas:chspc	Sets the channel space. Need to specify the unit. Example: meas:chspc_10_mhz (10MHz)
meas:chspc?	Returns the channel space in KHz.
meas:ocbw?	Returns the OCBW activation/deactivation status. Parameter: on,off
meas:ocbw	Turns On/Off OCBW. Parameter: on, off Example: meas:ocbw_on
meas:ocbw:bw?	Returns the OCBW in kHz.
meas:ocbw:chpw?	Returns the channel power in the current unit. I.e. dBm.
meas:ocbw:per?	Returns OCBW percentage.
meas:ocbw:per	Sets OCBW percentage. Example: meas:ocbw:per_90 (90%)
meas:ndb?	Returns N dB activation status. Parameter: on, off
meas:ndb	Turns on/off N dB. Parameter: on, off Example: meas:ndb_on
meas:nbw:bw?	Returns N dB bandwidth in kHz. Example: 1000 khz
meas:nbw:ndb	Sets N dB. Example: meas:nbw:ndb_3 (3 dB)
meas:nbw:ndb?	Returns the value of NdB.
meas:jitter?	Returns Phase Jitter on/off status. Parameter: on, off
meas:jitter	Turns On/Off Phase Jitter. Parameter: on, off Example: meas:jitter_on
meas:jitter:crpw?	Returns the carrier power in the current unit. I.e. dBm.
meas:jitter:stoffs?	Returns Phase Jitter start offset. Example: 0 khz
meas:jitter:stoffs	Sets Phase Jitter start offset. Need to specify the unit. Example: meas:jitter:stoffs_0_khz
meas:jitter:stpoffs?	Returns Phase Jitter stop offset. Example: 50 khz
meas:jitter:stpoffs	Sets Phase Jitter stop offset. Need to specify the unit. Example: meas:jitter:stpoffs_50_khz
meas:jitter:phase?	Returns Phase Jitter phase in radian. Example: 1.234 rad
meas:jitter:time?	Returns Phase Jitter time in pico second. Example: 1.234psec

Limit line

meas:lmpline:on	Turns On limit line. Parameter: 0 (low limit line), 1 (high limit line) Example: meas:lmpline:on_0 (low limit line On)
meas:lmpline:off	Turns Off limit line. Parameter: 0 (low limit line), 1 (high limit line) Example: meas:lmpline:off_0 (low limit line Off)
meas:lmpline:passfail?	Returns Pass/Fail test result. Parameter: 0 (Fail), 1 (Pass)
meas:lmpline:passfail	Turns On/Off Pass/Fail test. Parameter: on, off Example: meas:lmpline:passfail_on (Pass/Fail test On)

meas:lmtime: passfail:criterion?	Returns Pass/Fail test criteria. Parameter: 1 (pass if all signals are in the zone), 2 (pass if the peaks are in the zone), 3 (pass if valleys are in the zone)
meas:lmtime: passfail:criterion	Sets Pass/Fail test criteria. Parameter: 1 (pass if all signals are in the zone), 2 (pass if the peaks are in the zone), 3 (pass if valleys are in the zone) Example: meas:lmtime:passfail:criterion_3
meas:lmtime:table?	Returns limit line table On/Off. Parameter: on, off
meas:lmtime:table	Turns On/Off limit line table. Parameter: on, off Example: meas:lmtime:table_on (limit line table On)
meas:lmtime?	Returns the limit line table data. Need to specify 0 (low limit line), 1(high limit line) / limit line points. Example: meas:lmtime_0? Returns: 3,100,0,110,3,120,2 (low limit line, 3 points, 100MHz/0dB, 110MHz/3dB, 120MHz/2dB)
meas:lmtime:edit	Sets the limit line table data. Need to specify 0 (low limit line), 1(high limit line) / limit line points. Example: meas:lmtime:edit_0_CR_3,100,-2,110,-3,120,-2, (low limit line, 3 points, 100MHz/-2dB, 110MHz/-3dB,120MHz/-2dB)
meas:lmtime:edit: delall	Delete all points in limit line table. Parameter: 0 (low limit line), 1(high limit line) Example: meas:lmtime:edit:delall_0 (delete low lline table)

BW

con:rbw:auto	Sets RBW to auto.
con:rbw?	Returns the RBW (resolution bandwidth). Parameter: 0 (300Hz), 1 (3kHz), 2 (9kHz), 3 (10kHz), 4 (30kHz), 5 (100kHz), 6 (120kHz), 7 (300kHz), 8 (4MHz)
con:rbw:man	Selects the RBW. Parameter: 0 (300Hz), 1 (3kHz), 2 (9kHz), 3 (10kHz), 4 (30kHz), 5 (100kHz), 6 (120kHz), 7 (300kHz), 8 (4MHz) Example: con:rbw:man_1 (sets RBW to 300Hz)
con:rbw:mode?	Returns RBW mode. Parameter: auto, manual
con:vbw:auto	Sets VBW to auto.
con:vbw?	Returns the VBW. Parameter: 0 (10Hz), 1 (30Hz), 2 (100Hz), 3 (300Hz), 4 (1kHz), 5 (3kHz), 6 (10kHz), 7 (30kHz), 8 (100kHz), 9 (300kHz), 10 (1MHz)
con:vbw:man	Selects the VBW. Parameter: 0 (10Hz), 1 (30Hz), 2 (100Hz), 3 (300Hz), 4 (1kHz), 5 (3kHz), 6 (10kHz), 7 (30kHz), 8 (100kHz), 9 (300kHz), 10 (1MHz) Example: con:vbw:man_4 (sets VBW to 1kHz)
con:vbw:mode?	Returns VBW mode. Parameter: auto, manual
con:swt:auto	Sets the sweep time to auto.

con:swt:man	Sets the sweep time in msec. Example: con:swt:man_50 (sets the sweep time to 50ms)
con:swt?	Returns the sweep time in msec.
con:swt:mode?	Returns the sweep time mode. Parameter: auto, manual
con:allcouple	Sets the RBW, VBW, and sweep time to auto.

Trigger

con:trig:freerun	Sets the trigger to free run mode.
con:trig:video	Sets the trigger to video and sets the trigger level in current unit. Example: con:trig:video_-20 (video mode, -20dBm)
con:trig:single	Sets the trigger condition to single.
con:trig:cont	Sets the trigger condition to continuous.
con:trig:ext	Sets the trigger to external mode.
con:trig:delay	Sets the trigger delay in msec. Example: con:trig:delay_1000 (1000ms delay)
con:trig:freq	Sets the trigger frequency in MHz. Example: con:trig:freq_1 (1MHz)

Display

con:disp:dim	Selects the display dimmer level. Parameter: 0 to 5 Example: con:disp:dim_2 (dimmer level 2)
con:disp:dl	Turns On/Off display line. Parameter: on, off Example: con:disp:dl_on (display line On)
con:disp:dl:level	Sets the display line level in current unit. Example: con:disp:dl:level_-50 (display line at -50dBm)
con:disp:title:show	Sets and shows the display title. The title is case sensitive. Example: con:disp:title:show_SAtest (title is SAtest)
con:disp:title:clr	Clears the display title.
con:disp:split:upper	Turns On and sweeps upper window in split window mode.
con:disp:split:lower	Turns On and sweeps lower window in split window mode.
con:disp:split:alt	Sweeps the upper/lower window alternatively in split mode.
con:disp:split:full	Goes back to full screen mode.

File

con:file:copy	Copies file. Need to specify the source and destination file. Parameter: ta/tb/tc (traceA/B/C), t1to10 (trace1to10), lh/lI (high/low limit line), lh1to5 (high limit line 1to5), ll1to5 (low limit line 1to5), c1to5 (correction set 1to5), q1to10 (sequence 1to10), s1to10 (setup 1to10), file name in USB flash drive Example: con:file:copy_t10_ta (copy from trace10 to traceA) Example: con:file:copy_ta_mytrace (copy from traceA to a file in external USB flash named mytrace)
con:file:del	Deletes file. Need to specify the source and destination file. Parameter: ta/tb/tc (traceA/B/C), t1to10 (trace1to10), lh/lI (high/low limit line), lh1to5 (high limit line 1to5), ll1to5 (low limit line 1to5), c1to5 (correction set 1to5), q1to10 (sequence 1to10), s1to10 (setup file 1to10), file name in external USB flash drive. Example: con:file:del_t10 (delete trace10) Example: con:file:del_myspace (delete a file names myspace in external USB flash drive)
con:file:prtsc:tofile	Saves the display image to external USB flash drive. Need to specify the file name. Example: con:file:prtsc:tofile_myscreen (saves the display image to a file named myscreen)

Preset

con:preset Presets the ISA830/ISA830TG.

System

con:sys:setup:save	Save the current system setting. Parameter: 1to10 Example: con:sys:setup:save_1 (save current setup to setup1)
con:sys:setup:recall	Recalls a system setting from setup file. Parameter: 1to10 Example: con:sys:setup:recall_1 (recall setting in setup1 file)
con:sys:gpiaddr?	Returns the current GPIB address.
con:sys:gpiaddr	Sets the GPIB address. Example: con:sys:gpiaddr_2
con:sys:calsig	Turns On/Off the auxiliary signal. Parameter: on, off Example: con:sys:calsig_on (auxiliary signal On)
con:sys:clock:date?	Returns the current date setting. Parameter: year/month/ day/ day of week 1 (Mon) to 7(Sun) Example: 2006/6/24/6 (June 24 th , Saturday, 2006)
con:sys:clock:date	Sets the date. Parameter: year/month/day/ day of week 1 (Mon) to 7(Sun) Example: con:sys:clock:date_2006_6_24_6 (Jun24, Sat, 2006)

con:sys:clock:time?	Returns the current time setting. Parameter: hour : minute : second Example: 13:30:26 (1p.m., 30 minutes, 26 second)
con:sys:clock:time	Sets the time. Parameter: hour_minute_second Example: con:sys:clock:time_13_30_26 (1p.m., 30min, 26sec)
con:sys:clock:show	Turns On/Off clock display. Parameter: on, off Example: con:sys:clock:show_on (clock display On)
con:sys:selftest?	Returns the self test result. Parameter: 0 (fail), 1 (pass) in the following order: GPIB/Flash/SDRAM/RTC Example: 1 1 0 1 (GPIBpass,Flashpass,SDRAMfail,RTCpass)
con:sys:lang	Selects language. Parameter: 1 (English), 2 (Simplified Chinese) Example: con:sys:lang_2 (simplified Chinese)
con:sys:ser?	Returns the serial number. Example: EE8300000
con:sys:swver?	Returns the software version. Example: v1.20_080514 (version 1.20, 2008 May 14 th)
con:sys:fwver?	Returns the firmware version. Example: v1.03 (version 1.03)
con:sys:hwver?	Returns hardware version in following order. RF, IF, DSP, MB Example: v1.0 v1.02 v1.02 v1.01 (RF: version 1.0, IF: version 1.02, DSP: version 1.02, MB: version 1.01)
con:sys:optstatus?	Returns optional items installation status in the following order. 300HzRBW, EMIFilter, 10k/100kHzRBW, TG, Demodulator, Medref (± 1 ppm stability) Parameter: 0 (not installed), 1 (installed) Example: 0 0 1 1 1 (TG, Demodulator, Medref are installed)

Option

con:opt:tg	Turns On/Off Tracking Generator (TG). Parameter: on, off Example: con:opt:tg_on (TG On)
con:opt:tg:level?	Returns the TG level.
con:opt:tg:level	Sets the TG level.
con:opt:tg:norm	Turns On/Off TG normalization. Parameter: on, off Example: con:opt:tg:norm_on (normalization On)
con:opt:tg:refval?	Returns the TG reference value.
con:opt:tg:refval	Sets the TG reference value.
con:opt:dm:fm	Turns On/Off FM in the demodulator. Parameter: on, off Example: con:opt:dm:fm_on (FM On)
con:opt:dm:am	Turns On/Off AM in the demodulator. Parameter: on, off Example: con:opt:dm:am_on (AM On)
con:opt:dm:spk	Turns On/Off phone output in the demodulator. Parameter: on, off Example: con:opt:dm:spk_on (phone On)

con:opt:dm:vol	Sets the demodulator phone output volume.
con:opt:dm:sql?	Returns the demodulator squelch level.
con:opt:dm:sql	Sets the demodulator squelch level.
con:opt:bat?	Returns the battery level. (not supported)
con:opt:extreffreq?	Returns the external reference frequency.
con:opt:extreffreq	Sets the external reference frequency. Example: con:opt:extreffreq_1_mhz (1MHz)

Sequence

con:seq:runmode	Selects the sequence run mode. Parameter: 1 (repeat mode), 2 (single mode) Example: con:seq:runmode_2 (sequence runs in sing mode)
con:seq:runseq	Runs the sequence. Parameter: sequence index, 1 to 10 Example: con:seq:runseq_2 (run sequence 2)
con:seq:stopseq	Stops the running sequence.
con:seq:delallseq	Deletes all programmed sequence.
con:seq:delseq	Deletes a sequence. Parameter: sequence index, 1 to 10 Example: con:seq:delseq_2 (delete sequence 2)

FAQ

I pressed the power (ON/STBY) key on the front panel but nothing happens.

Make sure you turned on the rear panel power switch. For details, see page24.

Note that after proper sequence, it takes around 10 seconds for the display to become active.

I cannot even see the default green line on the display.

Check if the TraceBlank (hide trace from the display) is on for TraceA, the default waveform.

Press the Trace key→F1 (select TraceA)→F2 (Clear) to recover the trace. For details, see page101.

I connected the signal but it does not appear on screen.

Run the Autoset and let the ISA830/ISA830TG find the best display scale for your target signal.

Press the Autoset key, then press F1 (Autoset). For details, see page75.

I want to see which optional items are installed.

Check the optional item status in the system information window. Press the System key → F6 (More) → F4 (System Config On). For details, see page171.

The ISA830/ISA830TG performance does not match the specification.

Make sure the device is powered on for at least 30 minutes, within +18 to+28°C. This is necessary to stabilize the unit to match the specification.

If there is still a problem, please contact your local dealer.

Appendix

ISA830/ISA830TG Specifications

The following specifications apply when the ISA830/ISA830TG is powered on for at least 30 minutes within +18 to +28°C.

Frequency	Frequency Range	9kHz to 3.0GHz
	Aging Rate	± 10ppm, 0 to 50°C, 5ppm/yr
	Span Range	2kHz to 3.0GHz in 1/2/5 sequence, full span, zero span
	Phase Noise	-80dBc/Hz @ 1GHz 20kHz Offset typical
	Sweep Time Range	50ms to 25.6s
Resolution Bandwidth	RBW Range	3kHz, 30kHz, 300kHz, 4MHz
	RBW Accuracy	15%
	VBW Range	10Hz to 1MHz in 1-3 steps
Amplitude	Measurement Range (Span: 50kHz, RBW: 3kHz)	-103dBm to +20dBm: 1 MHz to 15MHz, Ref Lvl @ -30dBm -117dBm to +20dBm: 15MHz to 1GHz, Ref Lvl ≥ -110dBm -114dBm to +20dBm: 1GHz to 3GHz, Ref Lvl ≥ -110dBm
	Overload Protection	Max. +30dBm, 25V_dc
	Reference Level Range	-110dBm to +20dBm
	Accuracy	±1dB @100MHz
	Frequency Flatness	±1dB
	Display Range Linearity	±1dB over 70dB
Dynamic Range	Average Noise Floor	< -135±1dBm/Hz: 1MHz to 15MHz, Ref Lvl @ -30dBm < -149dBm/Hz, typical -152dBm/Hz: 15MHz to 1GHz, Ref Lvl ≥ -110dBm < -146dBm/Hz, typical -149dBm/Hz: 1GHz to 3GHz, Ref Lvl ≥ -110dBm
	Third Intermodulation	<-70dBc, RF Input @-40dBm, Ref Level @ -30dBm
	Harmonic Distortion	<-60dBc typical, RF Input < -40dBm, Ref Level @-30dBm
	Non-Harmonic	< -93dBm: 1MHz to 15MHz,

	Spurious (Span: 50kHz, RBW: 3kHz)	RefLvl \geq -30dBm < -107dBm: 15MHz to 1GHz, RefLvl \geq -110dBm < -104dBm: 1GHz to 3GHz, RefLvl \geq -110dBm
General	Display	640 x 480 high-res color TFT LCD
	Split Windows	Active Window: Upper, Lower, or Alternate (two simultaneously sweeping windows)
	Markers	10 markers for peaks: 5 normal-delta marker pairs. Function: Delta, To Peak, To Minimum, Peak Track, Peak Table, Peak Sort
	Trace Detection	3 traces with Peak, Maximum hold, Freeze, Average, and Trace Math
	Power Measurement	ACPR, OCBW, Channel power, N dB, and Phase Jitter
	Autoset Function	Auto tuning the measurement result for observation
	Trigger	Conditions: Video, External (Positive-going +5V-TTL ext. signal) Modes: Normal, Single, Continuous
	Sequence	Automated test by user defined macros without any remote controller. 10 sequential macro sets and 10 macros per each set. Variable Delays and Wait-to-Go facilitate automated measurement. Do-Sequence links and nests different sequence sets.
Connectors	RF Input	Type: N Female, 50 Ω nominal RF input VSWR: <2:1, @0dBm Ref Lvl
	External Reference Clock Input (MHz)	Type: BNC Female, 1M, 1.544M, 2.048M, 5M, 10M, 10.24M, 13M, 15.36M, 15.4M, 19.2M
	Ref. Clock Output	Type: BNC Female, 10MHz
	DC Input (DC Power Operation)	Jack: 5.5mm, 12V
	DC Output (for pre-amplifier)	Type: SMA Male, output +9V/100mA max.
Interface	RS-232C	Sub-D 9pins Female
	USB Connector	USB Host/Device fully supported Front Panel: Type A receptacle for USB flash drives. Rear Panel: Type mini-B receptacle for PC remote control.
	VGA Output	Sub-D 15pins Female
Accessories	User Manual x1, Power Cord x1, USB Cable (Type A plug to Type mini-B	

	plug) x 1
Power Source	AC 100V to 240V, 50/60Hz
Dimensions & Weight	330 (W) × 170(H) × 340(D) mm, Approx. 6kg
Operation Environment	Temperature: 18 to 28°C Relative Humidity: < 90%
Storage Environment	Temperature: 0 to 40°C Relative Humidity: < 85%

Optional Items Specifications

Opt.01 Tracking Generator	Frequency Range	9kHz to 3.0GHz
	Amplitude Range	-50dBm to 0 dBm
	Amplitude Accuracy	± 1 dB @100MHz, 0dBm
	Amplitude Flatness	± 1 dB @0dBm
	Harmonics	<-30dBc typical
	Reverse Power	+30dBm
	Impedance	Type: N female, 50 Ω nominal
	RF Output VSWR	< 2:1

RS Components Ltd

This manual contains proprietary information, which is protected by copyrights. All rights are reserved. No part of this manual may be photocopied, reproduced or translated into another language without prior written consent of RS Components.

The information in this manual was correct at the time of printing. Due to product improvements, RS Components reserves the rights to change specification, equipment, and maintenance procedures at any time without notice.

