

A (10 : 1)

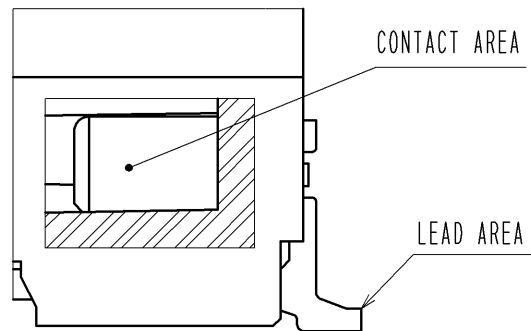

RECOMMENDED PCB LAYOUT (MOUNTING SURFACE SIDE) (FREE)

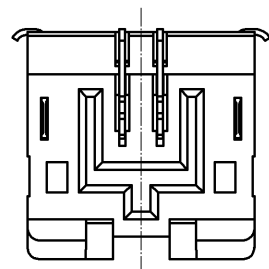
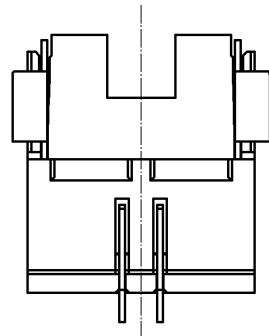
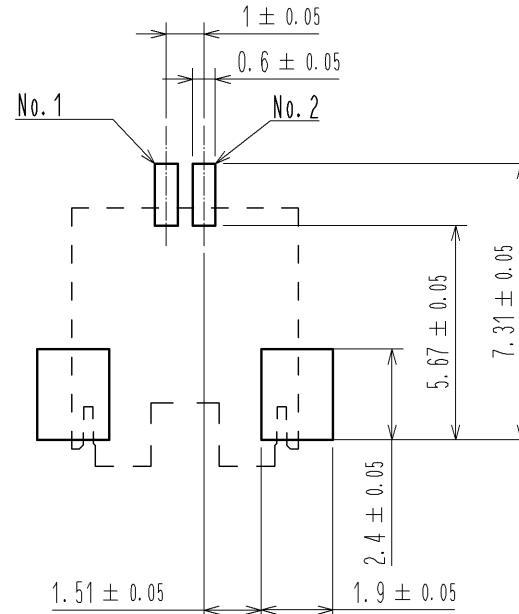

RECOMMENDED METAL MASK (FREE)

THICKNESS : 0.1mm
OPEN AREA RATIO:100%

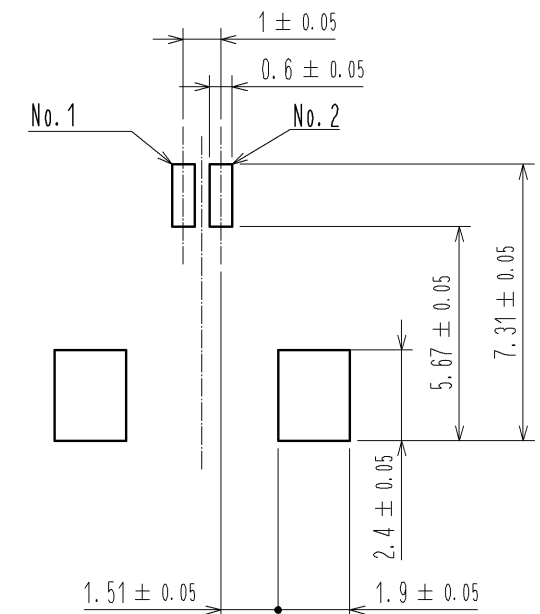

MATING FIGURE(5:1)

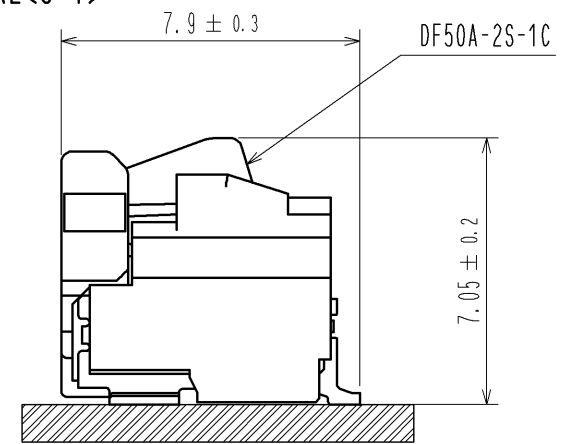
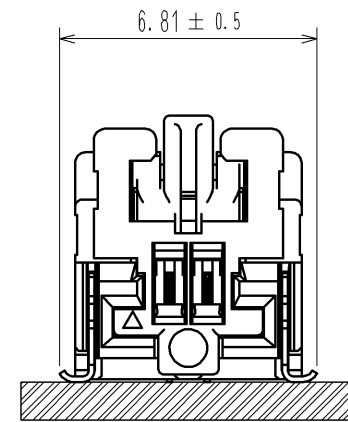

- NOTES 1. LEAD CO-PLANARITY SHALL BE 0.1mm MAX
- 2. PLEASE CONSULT HIROSE WHEN THE PRODUCT IS MOUNTED TO FPC.

3	BRASS	CONTACT AREA : Sn PLATING 1μm MIN UNDER PLATING : Cu PLATING 0.3μm MIN	6	PS	REEL , BLACK
2	BRASS	CONTACT AREA : Au PLATING 0.05μm MIN LEAD AREA : Au PLATING 0.05μm MIN UNDER PLATING : Ni PLATING 1μm MIN	5	POLYESTER	CLEAR
1	LCP	BLACK , UL94V-0	4	PS	CLEAR
NO.	MATERIAL	FINISH , REMARKS	NO.	MATERIAL	CLEAR

UNITS mm		SCALE 5 : 1	COUNT 	DESCRIPTION OF REVISIONS	DESIGNED	CHECKED	DATE
APPROVED : KI. AKIYAMA 12.07.02				DRAWING NO. EDC3-335023-01			
CHECED : HK. UMEHARA 12.07.02				PART NO. DF50A-2P-1H(51)			
DESIGNED : ST. SATO 12.06.29				CODE NO. CL665-1031-4-51			
DRAWN : MI. SAKIMURA 12.06.27							

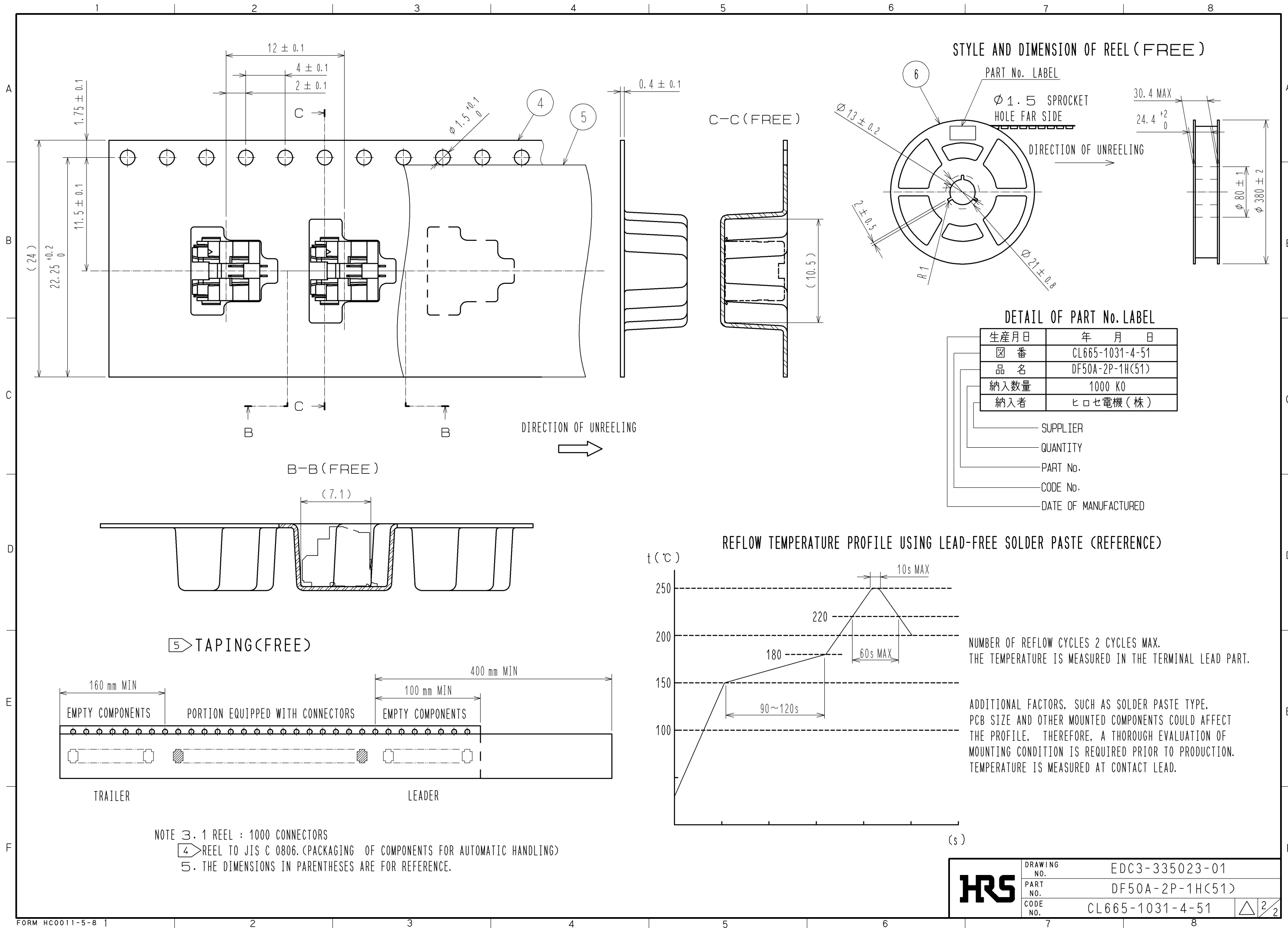

HRS	DRAWING NO.	EDC3-335023-01
	PART NO.	DF50A-2P-1H(51)
	CODE NO.	CL665-1031-4-51
		$\triangle 2/2$