



## 770-005A2 Type 2 Low Smoke Zero Halogen 90° Right Angle Lipless Shrink Boots

### Type 2 Low Smoke Zero Halogen (LSZH) For Regulated Environmental Safety Applications



- *Low Smoke, Zero Halogen*
- *Meets U.S. and E.U. toxicity requirements.*
- *-30° C to +135° C*

Halogen-free polyolefin boots meet low smoke and toxicity requirements of shipboard, transit and aircraft systems. Oxygen index greater than 30%, smoke index less than 20, and toxicity index under 3 per 100 grams. Material meets requirements of NAVSEA 5617649, VG95343 Part 29, BSG 198-5-DF, EN62329-101 and SAE AS5258 Type G. Good resistance to oils, fuels and solvents. Available with high temperature hot melt adhesive lining, these boots provide strain relief and environmental protection to connector/cable transitions. 90° angled configuration aids in efficient routing of wire harnesses and cables. Temperature rating -30° to +135° C. Black color.

Boot Size	Part Number			
	No Adhesive Lining	Pre-Coated with <i>W1</i> Hi-Temp Hot-Melt Adhesive	Pre-Coated with <i>W2</i> Standard Hot-Melt Adhesive	Pre-Coated with <i>R</i> Epoxy Adhesive
00	<a href="#">770-005A200</a>	<a href="#">770-005A200W1</a>	<a href="#">770-005A200W2</a>	<a href="#">770-005A200R</a>
02	<a href="#">770-005A202</a>	<a href="#">770-005A202W1</a>	<a href="#">770-005A202W2</a>	<a href="#">770-005A202R</a>
03	<a href="#">770-005A203</a>	<a href="#">770-005A203W1</a>	<a href="#">770-005A203W2</a>	<a href="#">770-005A203R</a>
04	<a href="#">770-005A204</a>	<a href="#">770-005A204W1</a>	<a href="#">770-005A204W2</a>	<a href="#">770-005A204R</a>
05	<a href="#">770-005A205</a>	<a href="#">770-005A205W1</a>	<a href="#">770-005A205W2</a>	<a href="#">770-005A205R</a>
06	<a href="#">770-005A206</a>	<a href="#">770-005A206W1</a>	<a href="#">770-005A206W2</a>	<a href="#">770-005A206R</a>
07	<a href="#">770-005A207</a>	<a href="#">770-005A207W1</a>	<a href="#">770-005A207W2</a>	<a href="#">770-005A207R</a>
08	<a href="#">770-005A208</a>	<a href="#">770-005A208W1</a>	<a href="#">770-005A208W2</a>	<a href="#">770-005A208R</a>

Add "**-PP**" to the end of any part number for potting ports.

Dimensions in inches (millimeters) and are subject to change without notice.

© 2011 Glenair, Inc.

CAGE Code 06324

Printed in U.S.A.

**GLENAIR, INC. • 1211 AIR WAY • GLENDALE, CA 91201-2497 • 818-247-6000 • FAX 818-500-9912**

www.glenair.com

**E-4**

E-Mail: sales@glenair.com

## Lipless Right Angle Shrink Boots: Dimensions

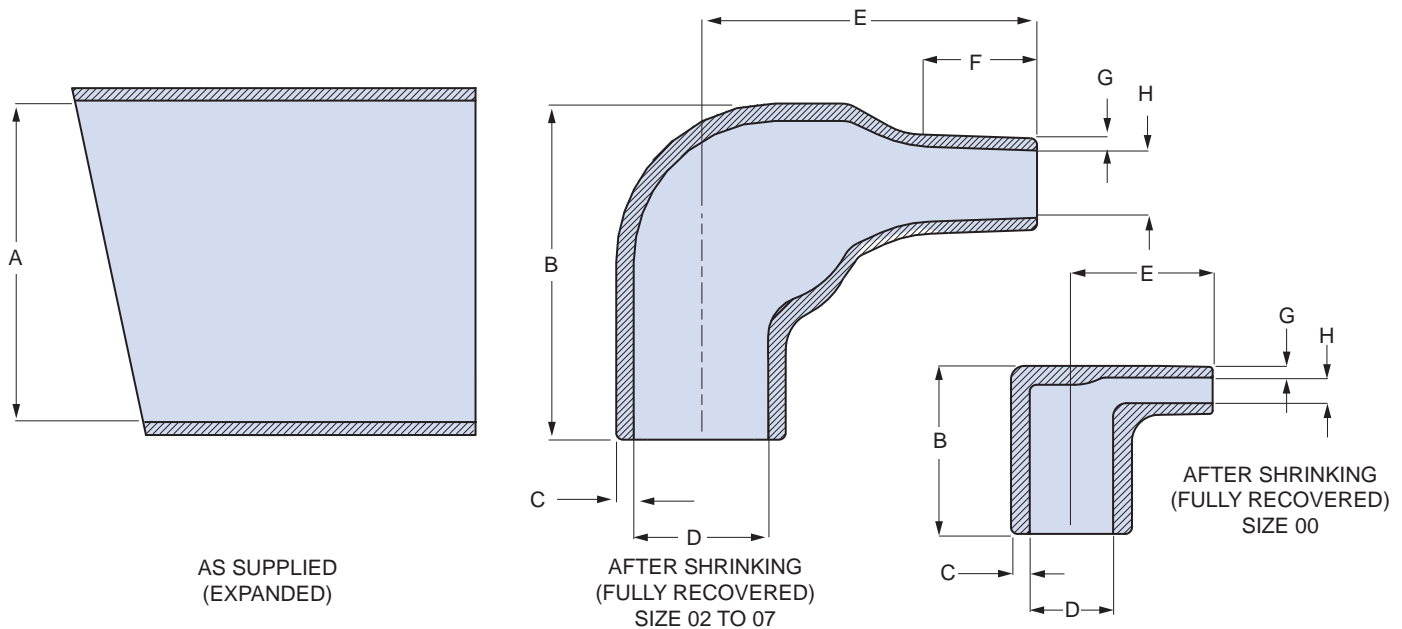

Boot Size	A Min.		B Ref.		C ±30%		D Max.		E ±20%		F Ref.		G ±20%		H Max.	
	In.	mm.	In.	mm.	In.	mm.	In.	mm.	In.	mm.	In.	mm.	In.	mm.	In.	mm.
00	.354	9.0	.492	12.5	.039	1.0	.236	6.0	.413	10.5	NA	NA	.028	0.7	.079	2.0
02	.669	17.0	.787	20.0	.051	1.3	.315	8.0	.787	20.0	.276	7.0	.028	0.7	.138	3.5
03	.945	24.0	.984	25.0	.063	1.6	.394	10.0	.984	25.0	.394	10.0	.035	0.9	.197	5.0
04	1.181	30.0	1.063	27.0	.071	1.8	.532	13.5	1.260	32.0	.472	12.0	.039	1.0	.217	5.5
05	1.260	32.0	1.260	32.0	.071	1.8	.709	18.0	1.535	39.0	.591	15.0	.047	1.2	.276	7.0
06	1.417	36.0	1.496	38.0	.079	2.0	.886	22.5	1.929	49.0	.630	16.0	.047	1.2	.335	8.5
07	1.693	43.0	1.850	47.0	.087	2.2	1.102	28.0	2.165	55.0	.709	18.0	.059	1.5	.394	10.0
08	2.050	52.0	3.150	80.0	.130	3.3	1.380	35.1	3.150	80.0	1.260	32.0	.060	1.5	1.380	35.1

## Lipless Right Angle Boots: Part Marking, Raised Lettering

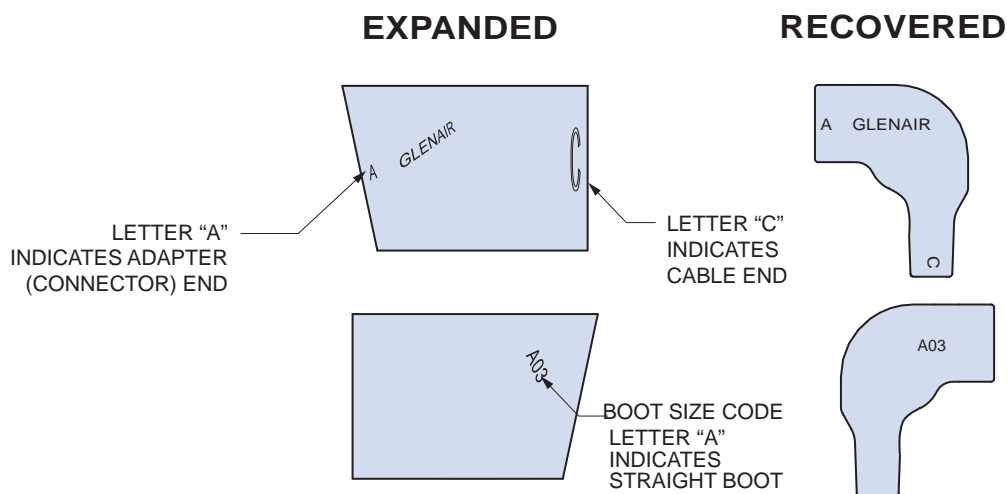

Dimensions in inches (millimeters) and are subject to change without notice.