



IMPORTANT NOTICE

Dear customer,

As from February 2nd 2009, ST and Ericsson have merged Ericsson Mobile Platforms and ST-NXP Wireless into a 50/50 joint venture "ST-Ericsson".

As a result, the following changes are applicable to the attached document.

- **Company name** - *ST-NXP Wireless* is replaced with **ST-Ericsson**.
- **Copyright** - the copyright notice at the bottom of each page "© ST-NXP Wireless 200x - All rights reserved", shall now read: "© ST-Ericsson, 2009 - All rights reserved".
- **Web site** - <http://www.stnwireless.com> is replaced with www.stericsson.com
- **Contact information** - the list of sales offices previously obtained at <http://www.stnwireless.com>, is now found at www.stericsson.com under Contacts

If you have any questions related to the document, please contact our nearest sales office or wired.support@stericsson.com.

Thank you for your cooperation and understanding.

ISP1160/01

Embedded USB Host Controller

Rev. 06 — 28 January 2009

Product data sheet

1. General description

The ISP1160/01 is an embedded Universal Serial Bus (USB) Host Controller (HC) that complies with *Universal Serial Bus Specification Rev. 2.0*, supporting data transfer at full-speed (12 Mbit/s) and low-speed (1.5 Mbit/s). The ISP1160/01 provides two downstream ports. Each downstream port has an overcurrent (OC) detection input pin and power supply switching control output pin. The downstream ports for the HC can be connected with any USB compliant USB devices and USB hubs that have USB upstream ports.

The ISP1160/01 is well suited for embedded systems and portable devices that require a USB host. The ISP1160/01 brings high flexibility to the systems that have it built-in. For example, a system that has the ISP1160/01 built-in allows it to be connected to a device that has a USB upstream port, such as a USB printer, USB camera, USB keyboard, USB mouse, among others.

2. Features

- Complies with *Universal Serial Bus Specification Rev. 2.0*
- Supports data transfer at full-speed (12 Mbit/s) and low-speed (1.5 Mbit/s)
- Adapted from *Open Host Controller Interface Specification for USB Release 1.0a*
- Selectable one or two downstream ports for HC
- High-speed parallel interface to most of the generic microprocessors and Reduced Instruction Set Computer (RISC) processors such as:
 - ◆ Hitachi SuperH SH-3 and SH-4
 - ◆ MIPS-based RISC
 - ◆ ARM7, ARM9, and StrongARM
- Maximum 15 Mbyte/s data transfer rate between the microprocessor and the HC
- Supports single-cycle and burst mode DMA operations
- Built-in FIFO buffer RAM for the HC (4 kbytes)
- Endpoints with double buffering to increase throughput and ease real-time data transfer for isochronous (ISO) transactions
- 6 MHz crystal oscillator with integrated PLL for low EMI
- Built-in software selectable internal 15 k Ω pull-down resistors for HC downstream ports
- Dedicated pins for suspend sensing output and wake-up control input for flexible applications
- Operation at either +5 V or +3.3 V power supply voltage
- Operating temperature range from -40 °C to +85 °C
- Available in two LQFP64 packages (SOT314-2 and SOT414-1).

ST-NXP Wireless

3. Applications

- Personal Digital Assistant (PDA)
- Digital camera
- Third-generation (3-G) phone
- Set-Top Box (STB)
- Information Appliance (IA)
- Photo printer
- MP3 jukebox
- Game console.

4. Ordering information

Table 1. Ordering information

Type number	Package		
	Name	Description	Version
ISP1160BD/01	LQFP64	plastic low profile quad flat package; 64 leads; body 10 × 10 × 1.4 mm	SOT314-2
ISP1160BM/01	LQFP64	plastic low profile quad flat package; 64 leads; body 7 × 7 × 1.4 mm	SOT414-1

5. Block diagram

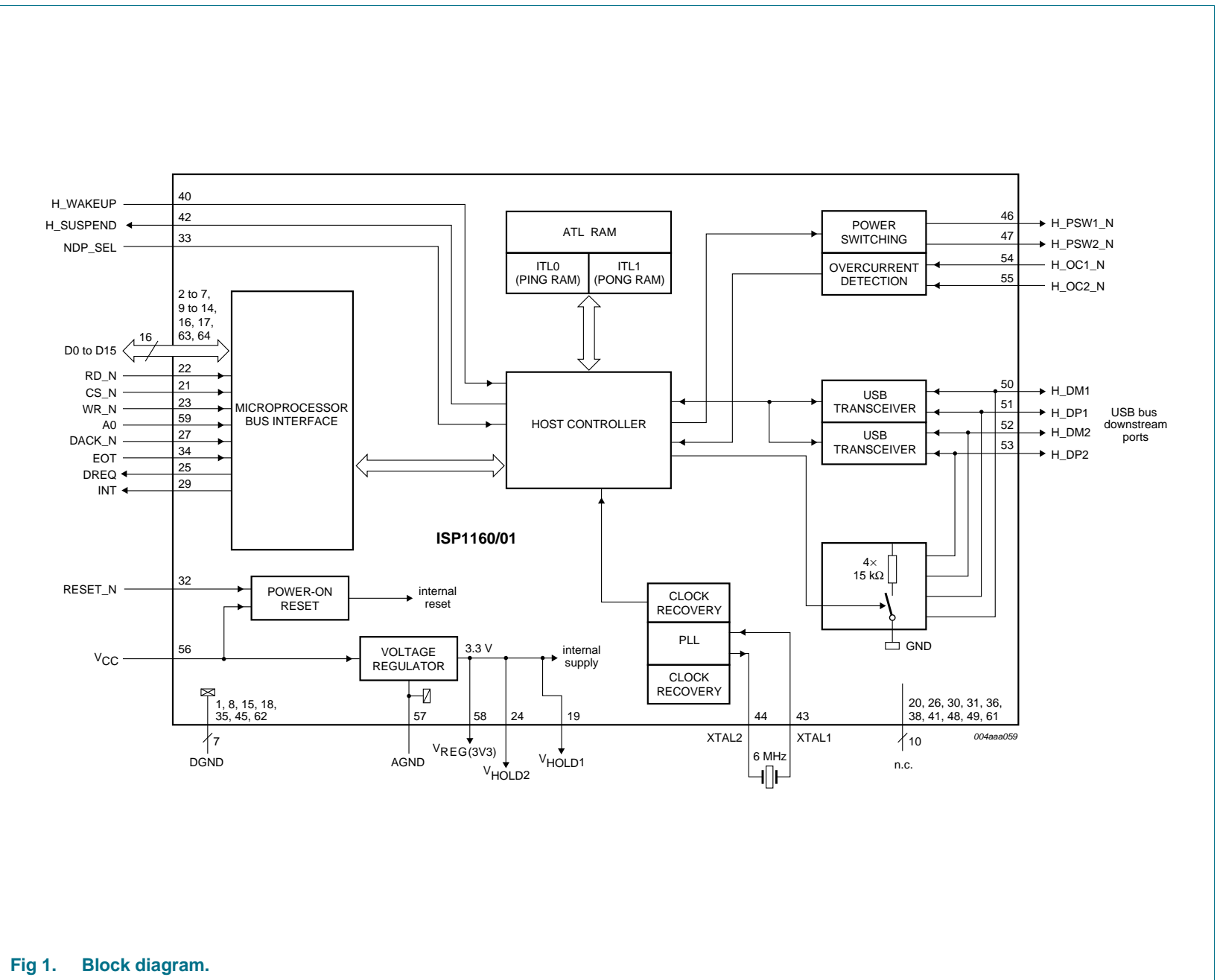
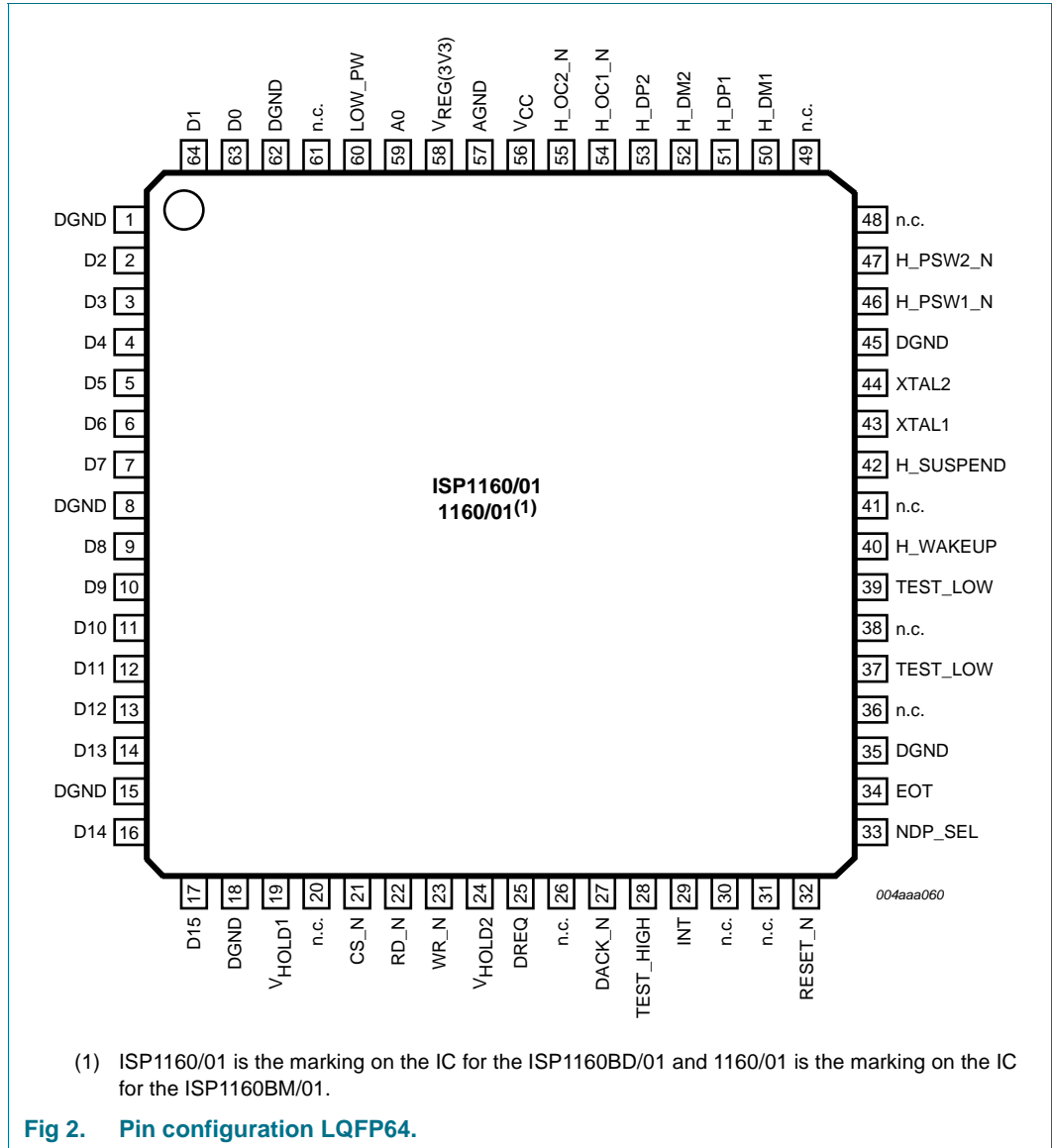

Fig 1. Block diagram.

6. Pinning information

6.1 Pinning



6.2 Pin description

Table 2. Pin description LQFP64

Symbol ^[1]	Pin	Type	Description
DGND	1	-	digital ground
D2	2	I/O	bit 2 of bidirectional data; slew-rate controlled; TTL input; three-state output
D3	3	I/O	bit 3 of bidirectional data; slew-rate controlled; TTL input; three-state output

Table 2. Pin description LQFP64 ...continued

Symbol ^[1]	Pin	Type	Description
D4	4	I/O	bit 4 of bidirectional data; slew-rate controlled; TTL input; three-state output
D5	5	I/O	bit 5 of bidirectional data; slew-rate controlled; TTL input; three-state output
D6	6	I/O	bit 6 of bidirectional data; slew-rate controlled; TTL input; three-state output
D7	7	I/O	bit 7 of bidirectional data; slew-rate controlled; TTL input; three-state output
DGND	8	-	digital ground
D8	9	I/O	bit 8 of bidirectional data; slew-rate controlled; TTL input; three-state output
D9	10	I/O	bit 9 of bidirectional data; slew-rate controlled; TTL input; three-state output
D10	11	I/O	bit 10 of bidirectional data; slew-rate controlled; TTL input; three-state output
D11	12	I/O	bit 11 of bidirectional data; slew-rate controlled; TTL input; three-state output
D12	13	I/O	bit 12 of bidirectional data; slew-rate controlled; TTL input; three-state output
D13	14	I/O	bit 13 of bidirectional data; slew-rate controlled; TTL input; three-state output
DGND	15	-	digital ground
D14	16	I/O	bit 14 of bidirectional data; slew-rate controlled; TTL input; three-state output
D15	17	I/O	bit 15 of bidirectional data; slew-rate controlled; TTL input; three-state output
DGND	18	-	digital ground
V _{HOLD1}	19	-	voltage holding pin 1; internally connected to the V _{REG(3V3)} and V _{HOLD2} pins. When V _{CC} is connected to 5 V, this pin will output 3.3 V, hence do not connect it to 5 V. When V _{CC} is connected to 3.3 V, this pin can either be connected to 3.3 V or left unconnected. In all cases, decouple this pin to DGND.
n.c.	20	-	no connection; leave this pin open
CS_N	21	I	chip select input
RD_N	22	I	read strobe input
WR_N	23	I	write strobe input
V _{HOLD2}	24	-	voltage holding pin 2; internally connected to the V _{REG(3V3)} and V _{HOLD1} pins. When V _{CC} is connected to 5 V, this pin will output 3.3 V, hence do not connect it to 5 V. When V _{CC} is connected to 3.3 V, this pin can either be connected to 3.3 V or left unconnected. In all cases, decouple this pin to DGND.
DREQ	25	O	HC DMA request output (programmable polarity); signals to the DMA controller that the ISP1160/01 wants to start a DMA transfer; see Section 10.4.1
n.c.	26	-	no connection; leave this pin open
DACK_N	27	I	HC DMA acknowledge input; when not in use, this pin must be connected to V _{CC} via an external 10 kΩ resistor

Table 2. Pin description LQFP64 ...continued

Symbol ^[1]	Pin	Type	Description
TEST_HIGH	28	-	this pin must be connected to V _{CC} via an external 10 kΩ resistor
INT	29	O	HC interrupt output; programmable level, edge triggered and polarity; see Section 10.4.1
n.c.	30	-	no connection; leave this pin open
n.c.	31	O	no connection; leave this pin open
RESET_N	32	I	reset input (Schmitt trigger); a LOW level produces an asynchronous reset (internal pull-up resistor)
NDP_SEL	33	I	indicates to the HC software the Number of Downstream Ports (NDP) present: 0 — select 1 downstream port 1 — select 2 downstream ports only changes the value of the NDP field in the HcRhDescriptorA register; both ports will always be enabled; see Section 10.3.1 (internal pull-up resistor)
EOT	34	I	DMA master device to inform the ISP1160/01 of end of DMA transfer; active level is programmable; when not in use, this pin must be connected to V _{CC} via an external 10 kΩ resistor; see Section 10.4.1
DGND	35	-	digital ground
n.c.	36	-	no connection; leave this pin open
TEST_LOW	37	-	this pin must be connected to DGND via an external 10 kΩ resistor
n.c.	38	-	no connection; leave this pin open
TEST_LOW	39	-	this pin must be connected to DGND via a 1 MΩ resistor
H_WAKEUP	40	I	HC wake-up input; generates a remote wake-up from the suspend state (active HIGH); when not in use, this pin must be connected to DGND via an external 10 kΩ resistor (internal pull-down resistor)
n.c.	41	-	no connection; leave this pin open
H_SUSPEND	42	O	HC suspend state indicator output; active HIGH
XTAL1	43	I	crystal input; connected directly to a 6 MHz crystal; when this pin is connected to an external clock source, pin XTAL2 must be left open
XTAL2	44	O	crystal output; connected directly to a 6 MHz crystal; when pin XTAL1 is connected to an external clock source, this pin must be left open
DGND	45	-	digital ground
H_PSW1_N	46	O	power switching control output for downstream port 1; open-drain output
H_PSW2_N	47	O	power switching control output for downstream port 2; open-drain output
n.c.	48	-	no connection; leave this pin open
n.c.	49	-	no connection; leave this pin open
H_DM1	50	AI/O	USB D– data line for HC downstream port 1

Table 2. Pin description LQFP64 ...continued

Symbol ^[1]	Pin	Type	Description
H_DP1	51	AI/O	USB D+ data line for HC downstream port 1
H_DM2	52	AI/O	USB D- data line for HC downstream port 2; when not in use, this pin must be left open
H_DP2	53	AI/O	USB D+ data line for HC downstream port 2; when not in use, this pin must be left open
H_OC1_N	54	I	overcurrent sensing input for HC downstream port 1
H_OC2_N	55	I	overcurrent sensing input for HC downstream port 2
V _{CC}	56	-	digital power supply input (3.0 V to 3.6 V or 4.75 V to 5.25 V). This pin supplies the internal 3.3 V regulator input. When connected to 5 V, the internal regulator will output 3.3 V to pins V _{REG(3V3)} , V _{HOLD1} and V _{HOLD2} . When connected to 3.3 V, it will bypass the internal regulator.
AGND	57	-	analog ground
V _{REG(3V3)}	58	-	internal 3.3 V regulator output; when pin V _{CC} is connected to 5 V, this pin outputs 3.3 V. When pin V _{CC} is connected to 3.3 V, connect this pin to 3.3 V.
A0	59	I	address input; selects command (A0 = 1) or data (A0 = 0)
LOW_PW	60	I	if low-current consumption (range of μ s) is needed during suspend, connect this pin to address A2; otherwise, connect to DGND
n.c.	61	-	no connection; leave this pin open
DGND	62	-	digital ground
D0	63	I/O	bit 0 of bidirectional data; slew-rate controlled; TTL input; three-state output
D1	64	I/O	bit 1 of bidirectional data; slew-rate controlled; TTL input; three-state output

[1] Symbol names ending with underscore N (for example, NAME_N) represent active LOW signals.

7. Functional description

7.1 PLL clock multiplier

A 6 MHz to 48 MHz clock multiplier Phase-Locked Loop (PLL) is integrated on-chip. This allows for the use of a low-cost 6 MHz crystal, which also minimizes EMI. No external components are required for the operation of the PLL.

7.2 Bit clock recovery

The bit clock recovery circuit recovers the clock from the incoming USB data stream by using a 4 times oversampling principle. It is able to track jitter and frequency drift as specified in *Universal Serial Bus Specification Rev. 2.0*.

7.3 Analog transceivers

Two sets of transceivers are embedded in the chip for downstream ports with USB connector type A. The integrated transceivers are compliant with the *Universal Serial Bus Specification Rev. 2.0*. These transceivers interface directly with the USB connectors and cables through external termination resistors.

7.4 ST-NXP Wireless Serial Interface Engine (SIE)

The ST-NXP Wireless SIE implements the full USB protocol layer. It is completely hardwired for speed and needs no firmware intervention. The functions of this block include: synchronization pattern recognition, parallel to serial conversion, bit (de)stuffing, CRC checking and generation, Packet Identifier (PID) verification and generation, address recognition, and handshake evaluation and generation.

8. Microprocessor bus interface

8.1 Programmed I/O (PIO) addressing mode

A generic PIO interface is defined for speed and ease-of-use. It also allows direct interfacing to most microcontrollers. To a microcontroller, the ISP1160/01 appears as a memory device with a 16-bit data bus and uses the A0 address line to access internal control registers and FIFO buffer RAM. Therefore, the ISP1160/01 occupies only two I/O ports or two memory locations of a microprocessor. External microprocessors can read from or write to the ISP1160/01's internal control registers and FIFO buffer RAM through the Programmed I/O (PIO) operating mode. [Figure 3](#) shows the Programmed I/O interface between a microprocessor and the ISP1160/01.

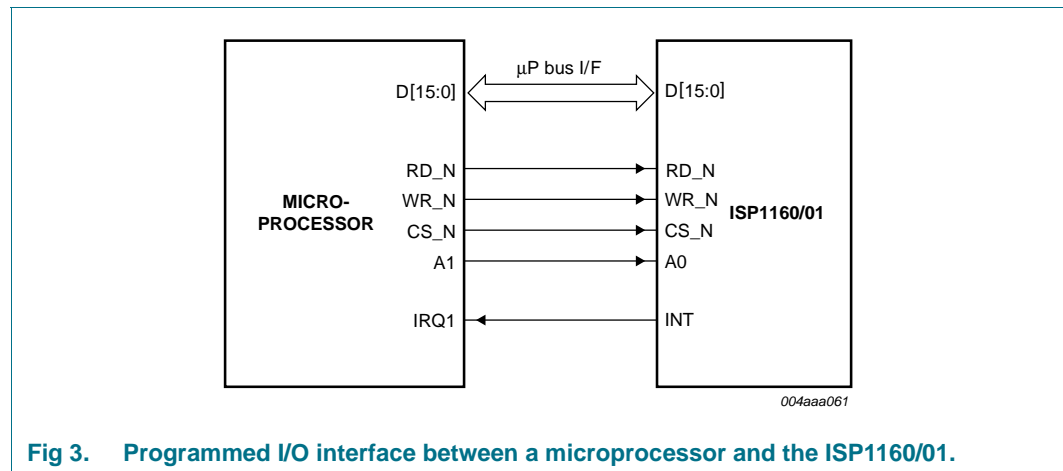

Fig 3. Programmed I/O interface between a microprocessor and the ISP1160/01.

8.2 DMA mode

The ISP1160/01 also provides the DMA mode for external microprocessors to access its internal FIFO buffer RAM. Data can be transferred by the DMA operation between a microprocessor's system memory and the ISP1160/01's internal FIFO buffer RAM.

Remark: The DMA operation must be controlled by the external microprocessor system's DMA controller (Master).

[Figure 4](#) shows the DMA interface between a microprocessor system and the ISP1160/01. The ISP1160/01 provides a DMA channel controlled by DREQ for DACK_N signals for the DMA transfer between a microprocessor's system memory and the ISP1160/01 HC's internal FIFO buffer RAM.

The EOT signal is an external end-of-transfer signal used to terminate the DMA transfer. Some microprocessors may not have this signal. In this case, the ISP1160/01 provides an internal EOT signal to terminate the DMA transfer as well. Setting the HcDMAConfiguration register (21H to read, A1H to write) enables the ISP1160/01's HC internal DMA counter for the DMA transfer. When the DMA counter reaches the value set in the HcTransferCounter register (22H to read, A2H to write), an internal EOT signal will be generated to terminate the DMA transfer.

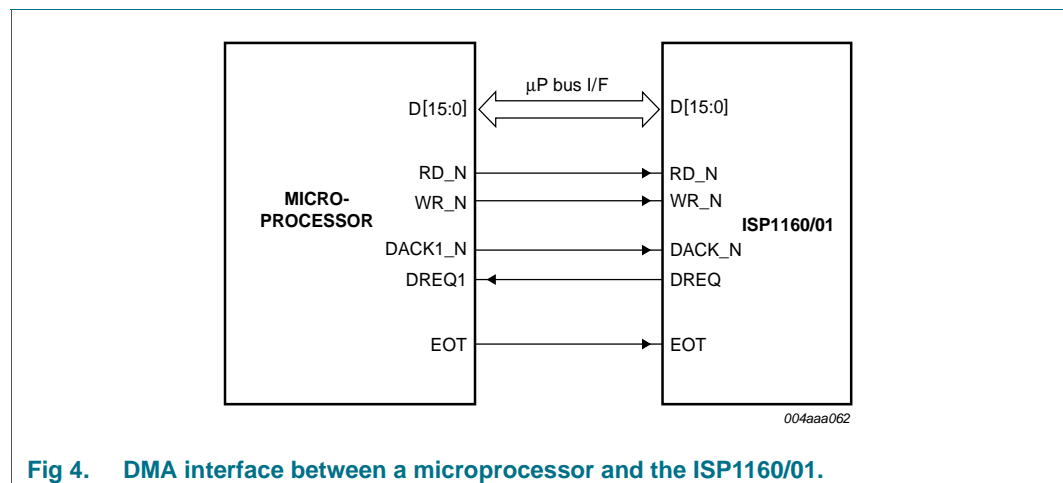

Fig 4. DMA interface between a microprocessor and the ISP1160/01.

8.3 Control registers access by PIO mode

8.3.1 I/O port addressing

Table 3 shows the ISP1160/01's I/O port addressing. Complete decoding of the I/O port address should include the chip select signal CS_N and the address line A0. However, the direction of access of I/O ports is controlled by the RD_N and WR_N signals. When RD_N is LOW, the microprocessor reads data from the ISP1160/01's data port. When WR_N is LOW, the microprocessor writes a command to the command port, or writes data to the data port.

Table 3. I/O port addressing

Port	CS_N	A0	Access	Data bus width (bits)	Description
0	0	0	R/W	16	HC data port
1	0	1	W	16	HC command port

Figure 5 illustrates how an external microprocessor accesses the ISP1160/01's internal control registers.

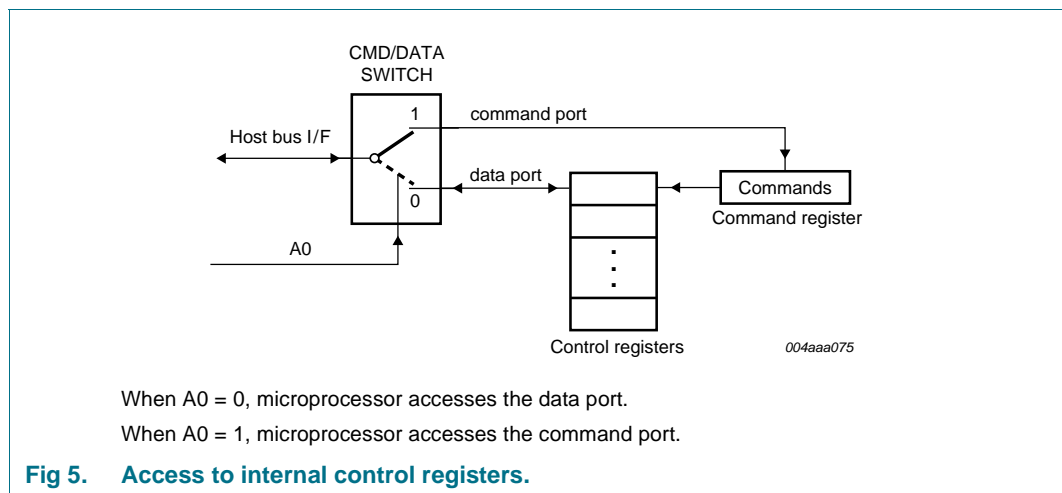

Fig 5. Access to internal control registers.

8.3.2 Register access phases

The ISP1160/01's register structure is a command-data register pair structure. A complete register access cycle comprises a command phase followed by a data phase. The command (also known as the index of a register) points the ISP1160/01 to the next register to be accessed. A command is 8 bits long. On a microprocessor's 16-bit data bus, a command occupies the lower byte, with the upper byte filled with zeros.

Figure 6 shows a complete 16-bit register access cycle for the ISP1160/01. The microprocessor writes a command code to the command port, and then reads from or writes the data word to the data port. Take the example of a microprocessor attempting to read the ISP1160/01's ID, which is saved in the HC's HcChipID register (index 27H, read only). The 16-bit register access cycle is therefore:

1. The microprocessor writes the command code of 27H (0027H in 16-bit width) to the HC command port
2. The microprocessor reads the data word of the chip's ID from the HC data port.

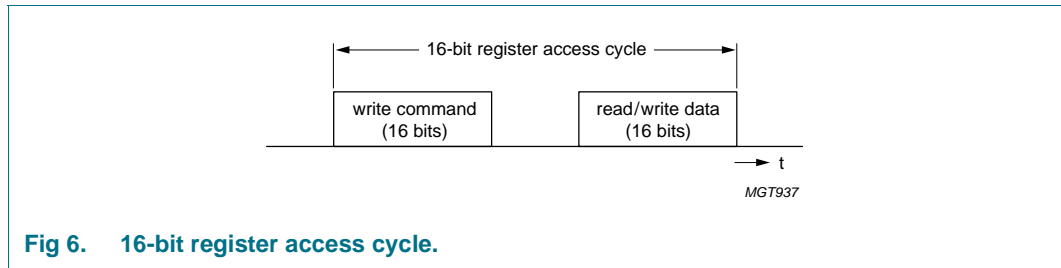

Fig 6. 16-bit register access cycle.

Most of the ISP1160/01’s internal control registers are 16-bit wide. Some of the internal control registers, however, are 32-bit wide. [Figure 7](#) shows how the ISP1160/01’s 32-bit internal control register is accessed. The complete cycle of accessing a 32-bit register consists of a command phase followed by two data phases. In the two data phases, the microprocessor first reads or writes the lower 16-bit data, followed by the upper 16-bit data.

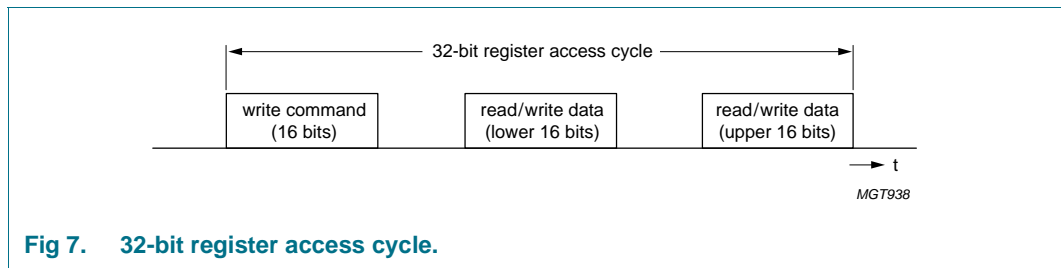

Fig 7. 32-bit register access cycle.

To further describe the complete access cycles of the internal control registers, the status of some pins of the microprocessor bus interface are shown in [Figure 8](#).

Signals	Valid status	Valid status	Valid status
CS_N	0	0	0
A0	1	0	0
RD_N, WR_N	RD_N = 1, WR_N = 0	RD_N = 0 (read) or WR_N = 0 (write)	RD_N = 0 (read) or WR_N = 0 (write)
data bus	Command code	Register data (lower word)	Register data (upper word)

004aaa370

Fig 8. Accessing HC control registers.

8.4 FIFO buffer RAM access by PIO mode

Since the ISP1160/01’s internal memory is structured as a FIFO buffer RAM, the FIFO buffer RAM is mapped to dedicated register fields. Therefore, accessing the internal FIFO buffer RAM is similar to accessing the internal control registers in multiple data phases.

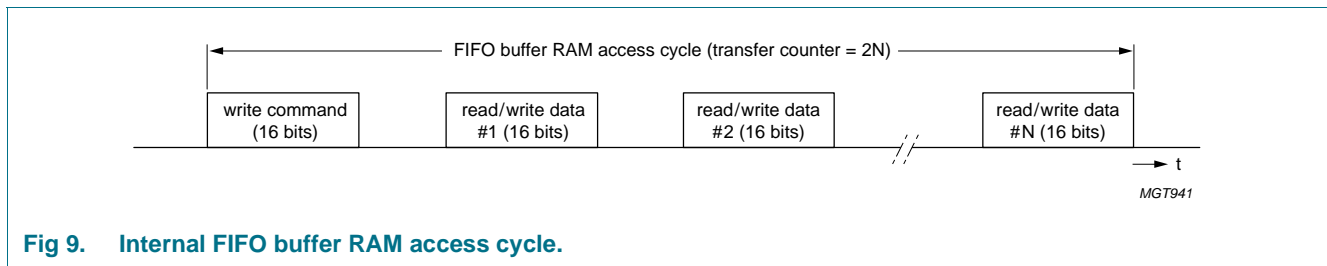

Fig 9. Internal FIFO buffer RAM access cycle.

[Figure 9](#) shows a complete access cycle of the HC internal FIFO buffer RAM. For a write cycle, the microprocessor first writes the FIFO buffer RAM's command code to the command port, and then writes the data words one by one to the data port until half of the transfer's byte count is reached. The HcTransferCounter register (22H to read, A2H to write) is used to specify the byte count of a FIFO buffer RAM's read cycle or write cycle. Every access cycle must be in the same access direction. The read cycle procedure is similar to the write cycle.

8.5 FIFO buffer RAM access by DMA mode

The DMA interface between a microprocessor and the ISP1160/01 is shown in [Figure 4](#).

When doing a DMA transfer, at the beginning of every burst the ISP1160/01 outputs a DMA request to the microprocessor via pin DREQ. After receiving this signal, the microprocessor will reply with a DMA acknowledge to the ISP1160/01 via pin DACK_N, and at the same time, execute the DMA transfer through the data bus. In the DMA mode, the microprocessor must issue a read or write signal to the ISP1160/01's pins RD_N or WR_N. The ISP1160/01 will repeat the DMA cycles until it receives an EOT signal to terminate the DMA transfer.

The ISP1160/01 supports both external and internal EOT signals. The external EOT signal is received as input on pin EOT, and generally comes from the external microprocessor. The internal EOT signal is generated inside the ISP1160/01.

To select either EOT method, set the appropriate DMA configuration register (see [Section 10.4.2](#)). For example, setting DMACounterSelect (bit 2) of the HcDMAConfiguration register (21H to read, A1H to write) to logic 1 will enable the DMA counter for DMA transfer. When the DMA counter reaches the value of the HcTransferCounter register, the internal EOT signal will be generated to terminate the DMA transfer.

The ISP1160/01 supports either single-cycle DMA operation or burst mode DMA operation; see [Figure 10](#) and [Figure 11](#).

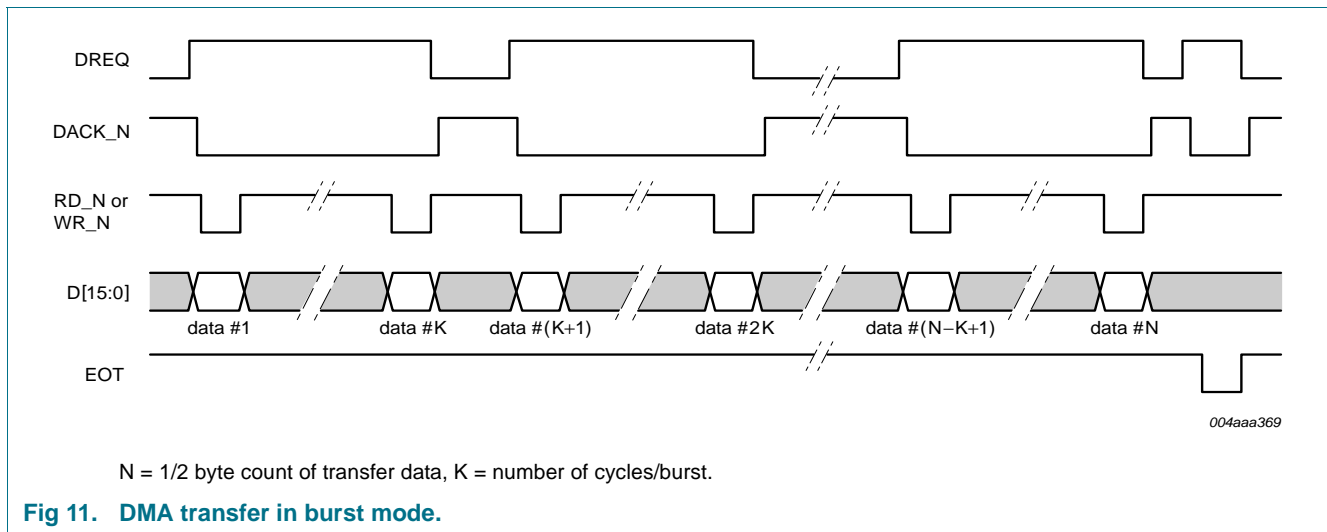
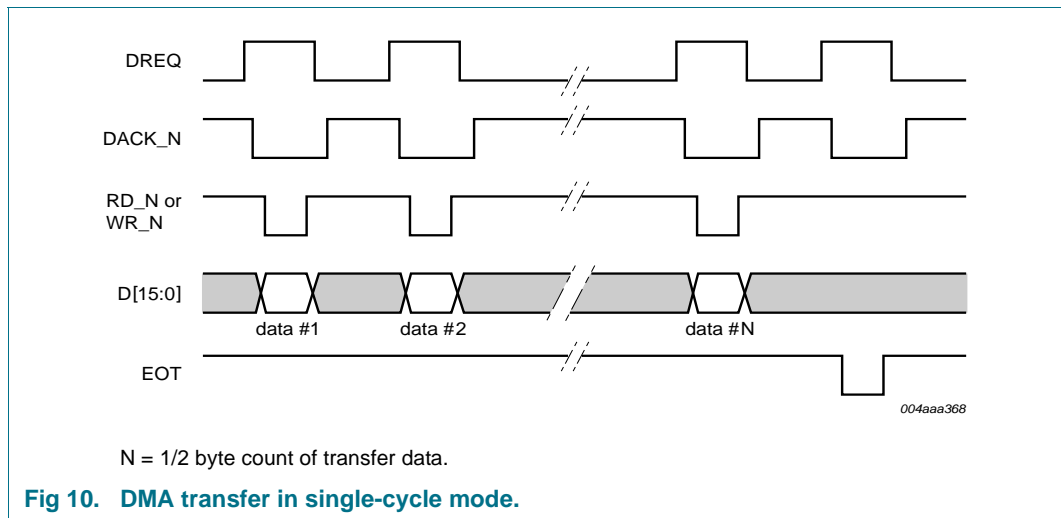

In [Figure 10](#) and [Figure 11](#), the DMA transfer is configured such that DREQ is active HIGH and DACK_N is active LOW.

8.6 Interrupts

The ISP1160/01 has an interrupt request pin INT.

8.6.1 Pin configuration

The interrupt output signals have four configuration modes:

- Mode 0 Mode 0 level trigger, active LOW
- Mode 1 Mode 1 level trigger, active HIGH
- Mode 2 Mode 2 edge trigger, active LOW
- Mode 3 Mode 3 edge trigger, active HIGH.

[Figure 12](#) shows these four interrupt configuration modes. They are programmable through the HcHardware Configuration register (see [Section 10.4.1](#)), which is also used to disable or enable the signals.

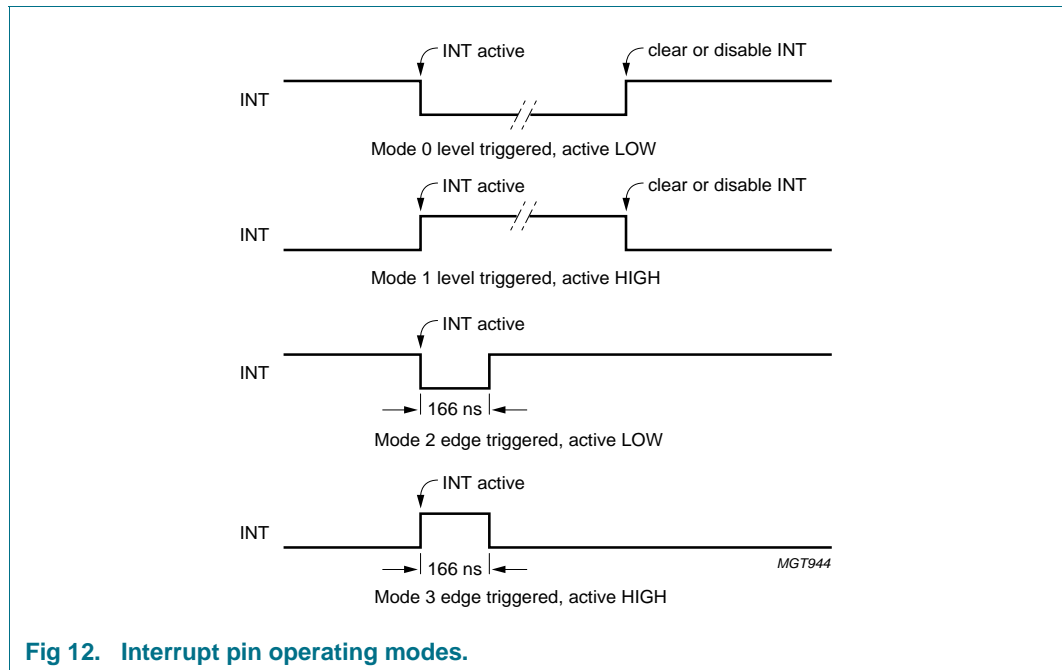

Fig 12. Interrupt pin operating modes.

8.6.2 Interrupt output pin (INT)

To program the four configuration modes of the HC's interrupt output signal (INT), set `InterruptPinTrigger` and `InterruptOutputPolarity` (bits 1 and 2) of the `HcHardwareConfiguration` register (20H to read, A0H to write). `InterruptPinEnable` (bit 0) is used as the master enable setting for pin INT.

INT has many associated interrupt events as shown as in [Figure 13](#).

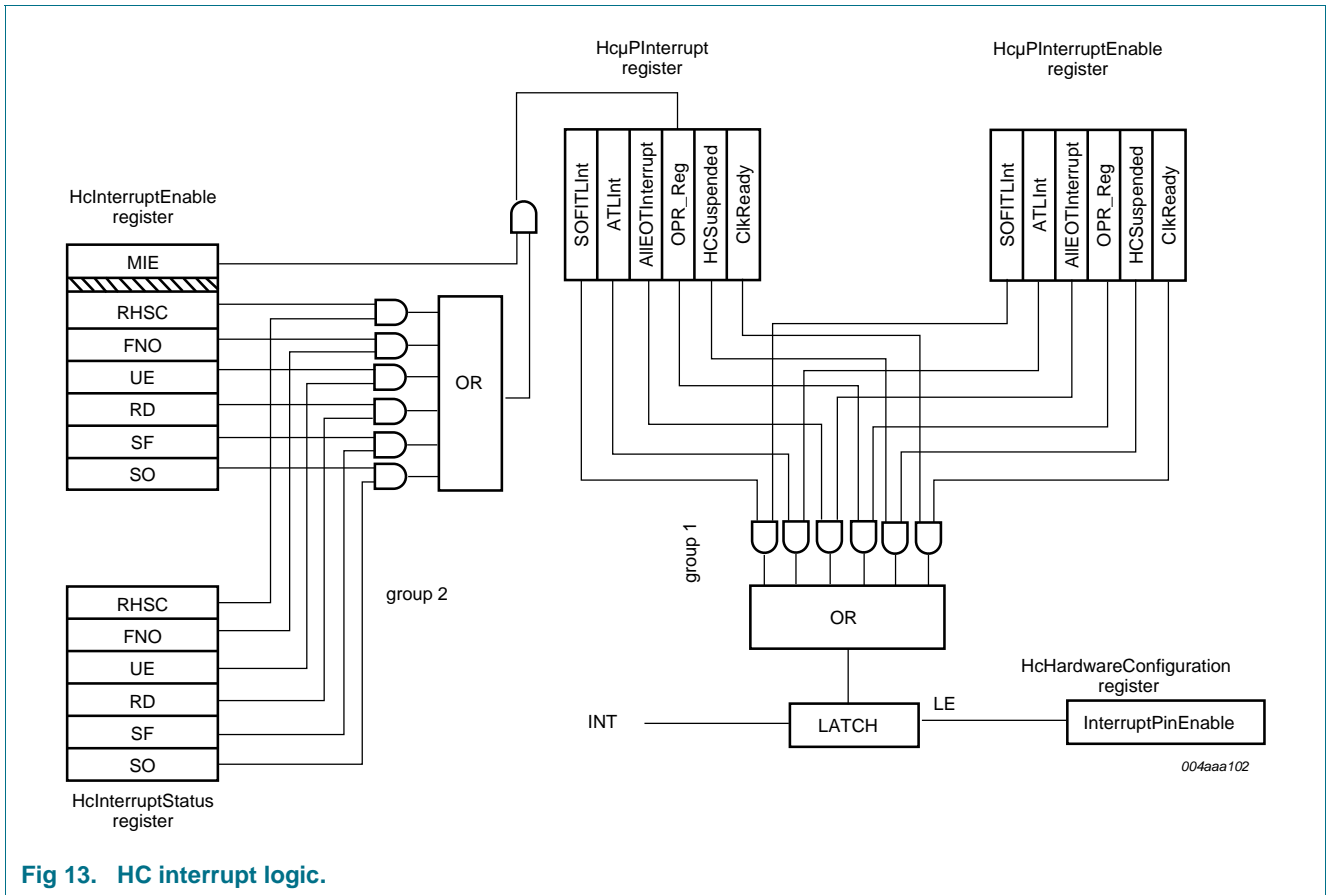

Fig 13. HC interrupt logic.

There are two groups of interrupts represented by group 1 and group 2 in [Figure 13](#). A pair of registers control each group.

Group 2 contains six possible interrupt events (recorded in the HcInterruptStatus register). On occurrence of any of these events, the corresponding bit would be set to logic 1; and if the corresponding bit in the HcInterruptEnable register is also logic 1, the 6-input OR gate would output a logic 1. This output is AND-ed with the value of MIE (bit 31 of HcInterruptEnable). Logic 1 at the AND gate will cause the OPR bit in the HcPIInterrupt register to be set to logic 1.

Group 1 contains six possible interrupt events, one of which is the output of group 2 interrupt sources. The HcPIInterrupt and HcPIInterruptEnable registers work in the same way as the HcInterruptStatus and HcInterruptEnable registers in the interrupt group 2. The output from the 6-input OR gate is connected to a latch, which is controlled by InterruptPinEnable (bit 0 of the HcHardwareConfiguration register).

In the event in which the software wishes to temporarily disable the interrupt output of the ISP1160/01 Host Controller, the following procedure should be followed:

1. Make sure that the InterruptPinEnable bit in the HcHardwareConfiguration register is set to logic 1.
2. Clear all bits in the HcPIInterrupt register.
3. Set the InterruptPinEnable bit to logic 0.

To re-enable the interrupt generation:

1. Set all bits in the HcμPInterrupt register.
2. Set the InterruptPinEnable bit to logic 1.

Remark: The InterruptPinEnable bit in the HcHardwareConfiguration register latches the interrupt output. When this bit is set to logic 0, the interrupt output will remain unchanged, regardless of any operations on the interrupt control registers.

If INT1 is asserted, and the Host Controller Driver (HCD) wishes to temporarily mask off the INT signal without clearing the HcμPInterrupt register, the following procedure should be followed:

1. Make sure that the InterruptPinEnable bit is set to logic 1.
2. Clear all bits in the HcμPInterruptEnable register.
3. Set the InterruptPinEnable bit to logic 0.

To re-enable the interrupt generation:

1. Set all bits in the HcμPInterruptEnable register according to the HCD requirements.
2. Set the InterruptPinEnable bit to logic 1.

9. Host Controller (HC)

9.1 HC's four USB states

The ISP1160/01's USB HC has four USB states—USBOperational, USBReset, USBSuspend and USBResume—that define the HC's USB signalling and bus states responsibilities. The signals are visible to the Host Controller Driver (HCD) via the ISP1160/01 USB HC's control registers.

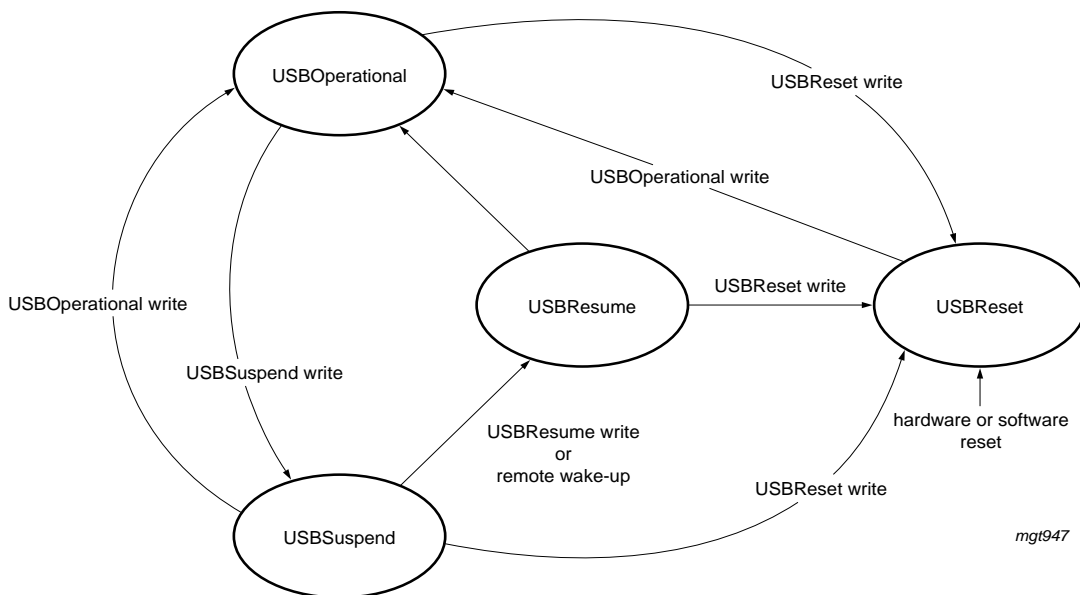

Fig 14. The ISP1160/01 HC's USB states.

The USB states are reflected in the HostControllerFunctionalState field of the HcControl register (01H to read, 81H to write), which is located at bits 7 and 6 of the register.

The HCD can perform only the USB state transitions shown in [Figure 14](#).

Remark: The Software Reset in [Figure 14](#) is not caused by the HcSoftwareReset command. It is caused by the HostControllerReset field of the HcCommandStatus register (02H to read, 82H to write).

9.2 Generating USB traffic

USB traffic can be generated only when the ISP1160/01 USB HC is in the USBOperational state. Therefore, the HCD must set the HostControllerFunctionalState field of the HcControl register before generating USB traffic.

A simplistic flow diagram showing when and how to generate USB traffic is shown in [Figure 15](#). For greater accuracy, refer to the *Universal Serial Bus Specification Rev. 2.0* for the USB protocol and the ISP1160/01 USB HC's register usage.

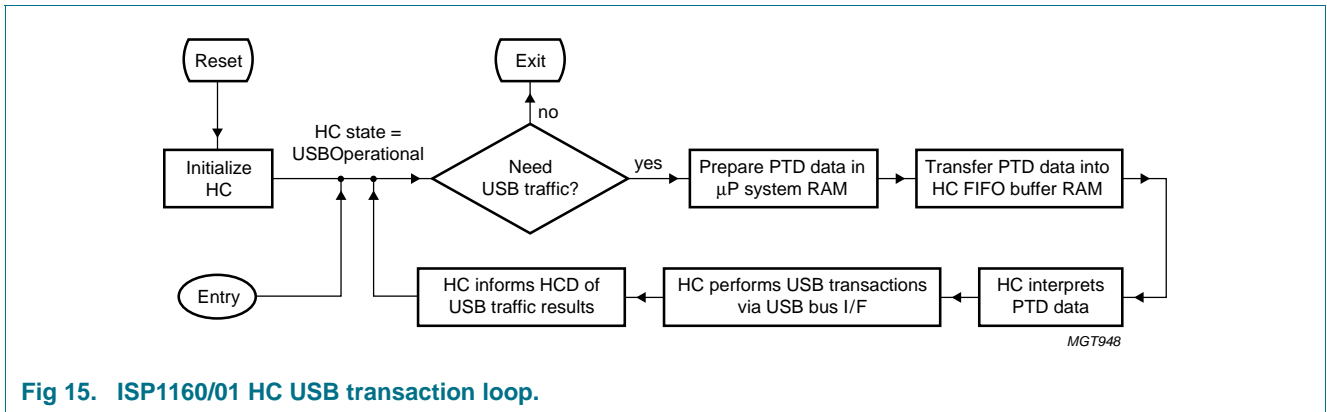

Fig 15. ISP1160/01 HC USB transaction loop.

Description of [Figure 15](#):

1. **Reset:** This includes hardware reset by pin RESET_N and software reset by the HcSoftwareReset command (A9H). The reset function will clear all the HC's internal control registers to their reset status. After reset, the HCD must initialize the ISP1160/01 USB HC by setting some registers.
2. **Initialize HC:** It includes:
 - a. Setting the physical size for the HC's internal FIFO buffer RAM by setting the HcITLBufferLength register (2AH to read, AAH to write) and the HcATLBufferLength register (2BH to read, ABH to write).
 - b. Setting the HcHardwareConfiguration register according to requirements.
 - c. Clearing interrupt events, if required.
 - d. Enabling interrupt events, if required.
 - e. Setting the HcFmInterval register (0DH to read, 8DH to write).
 - f. Setting the HC's Root Hub registers.
 - g. Setting the HcControl register to move the HC into the USBOperational state.

See also [Section 9.5](#).

3. **Entry:** The normal entry point. The microprocessor returns to this point when there are HC requests.
4. **Need USB traffic:** USB devices need the HC to generate USB traffic when they have USB traffic requests such as:
 - a. Connecting to or disconnecting from downstream ports
 - b. Issuing the Resume signal to the HC.To generate USB traffic, the HCD must enter the USB transaction loop.
5. **Prepare PTD data in μ P system RAM:** The communication between the HCD and the ISP1160/01 HC is in the form of Proprietary Transfer Descriptor (PTD) data. The PTD data provides USB traffic information about the commands, status and USB data packets.

The physical storage media of PTD data for the HCD is the microprocessor's system RAM. For the ISP1160/01's HC, the storage media is the internal FIFO buffer RAM.

The HCD prepares PTD data in the microprocessor's system RAM for transfer to the ISP1160/01's HC internal FIFO buffer RAM.
6. **Transfer PTD data into HC's FIFO buffer RAM:** When PTD data is ready in the microprocessor's system RAM, the HCD must transfer the PTD data from the microprocessor's system RAM into the ISP1160/01's internal FIFO buffer RAM.
7. **HC interprets PTD data:** The HC determines what USB transactions are required based on the PTD data that has been transferred into the internal FIFO buffer RAM.
8. **HC performs USB transactions via USB bus interface:** The HC performs the USB transactions with the specified USB device endpoint through the USB bus interface.
9. **HC informs HCD of the USB traffic results:** The USB transaction status and the feedback from the specified USB device endpoint will be put back into the ISP1160/01's HC internal FIFO buffer RAM in PTD data format. The HCD can read back the PTD data from the internal FIFO buffer RAM.

9.3 PTD data structure

The Proprietary Transfer Descriptor (PTD) data structure provides communication between the HCD and the ISP1160/01's USB HC. The PTD data contains information required by the USB traffic. PTD data consists of a PTD followed by its payload data, as shown in [Figure 16](#).

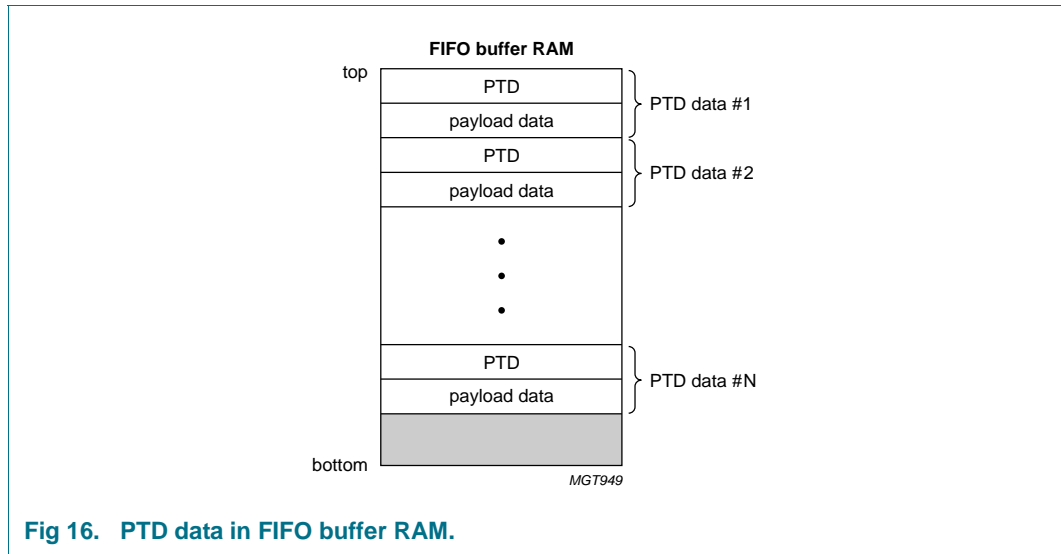

Fig 16. PTD data in FIFO buffer RAM.

The PTD data structure is used by the HC to define a buffer of data that will be moved to or from an endpoint in the USB device. This data buffer is set up for the current frame (1 ms frame) by the HCD. The payload data for every transfer in the frame must have a PTD as the header to describe the characteristic of the transfer. The PTD data is DWORD (double-word or 4-byte) aligned.

9.3.1 PTD data header definition

The PTD forms the header of the PTD data. It tells the HC the transfer type, where the payload data should go, and the actual size of the payload data. A PTD is an 8-byte data structure that is very important for HCD programming.

Table 4. Proprietary Transfer Descriptor (PTD): bit allocation

Bit	7	6	5	4	3	2	1	0	
Byte 0	ActualBytes[7:0]								
Byte 1	CompletionCode[3:0]			Active		Toggle	ActualBytes[9:8]		
Byte 2	MaxPacketSize[7:0]								
Byte 3	EndpointNumber[3:0]			Last		Speed	MaxPacketSize[9:8]		
Byte 4	TotalBytes[7:0]								
Byte 5	reserved		B5_5	reserved		DirectionPID[1:0]		TotalBytes[9:8]	
Byte 6	Format			FunctionAddress[6:0]					
Byte 7	reserved								

Table 5. Proprietary Transfer Descriptor (PTD): bit description

Symbol	Access			Description
ActualBytes[9:0]	R/W			Contains the number of bytes that were transferred for this PTD.
CompletionCode[3:0]	R/W	0000	NoError	General TD or isochronous data packet processing completed with no detected errors.
		0001	CRC	Last data packet from endpoint contained a CRC error.
		0010	BitStuffing	Last data packet from endpoint contained a bit stuffing violation.
		0011	DataToggleMismatch	Last packet from endpoint had data toggle PID that did not match the expected value.
		0100	Stall	TD was moved to the Done queue because the endpoint returned a STALL PID.
		0101	DeviceNotResponding	Device did not respond to token (IN) or did not provide a handshake (OUT).
		0110	PIDCheckFailure	Check bits on PID from endpoint failed on data PID (IN) or handshake (OUT).
		0111	UnexpectedPID	Received PID was not valid when encountered or PID value is not defined.
		1000	DataOverrun	The amount of data returned by the endpoint exceeded either the size of the maximum data packet allowed from the endpoint (found in the MaximumPacketSize field of endpoint descriptor) or the remaining buffer size.
		1001	DataUnderrun	The endpoint returned is less than MaximumPacketSize and that amount was not sufficient to fill the specified buffer.
		1010	reserved	-
		1011	reserved	-
		Active	R/W	1100
1101	BufferUnderrun			During an OUT, the HC could not retrieve data from the system memory fast enough to keep up with the USB data rate.
Toggle	R/W			Used to generate or compare the data PID value (DATA0 or DATA1). It is updated after each successful transmission or reception of a data packet.
MaxPacketSize[9:0]	R			The maximum number of bytes that can be sent to or received from the endpoint in a single data packet.
EndpointNumber[3:0]	R			USB address of the endpoint within the function.
Last	R			Last PTD of a list (ITL or ATL). Logic 1 indicates that the PTD is the last PTD.
Speed	R			Speed of the endpoint:
				0 — full speed 1 — low speed
TotalBytes[9:0]	R			Specifies the total number of bytes to be transferred with this data structure. For Bulk and Control only, this can be greater than MaximumPacketSize.

Table 5. Proprietary Transfer Descriptor (PTD): bit description ...continued

Symbol	Access	Description	
DirectionPID[1:0]	R	00	SETUP
		01	OUT
		10	IN
		11	reserved
B5_5	R/W	This bit is logic 0 at power-on reset. When this feature is not used, software used for the ISP1160/01 is the same for the ISP1161 and the ISP1161A. When this bit is set to logic 1 in this PTD for interrupt endpoint transfer, only one PTD USB transaction will be sent out in 1 ms.	
Format	R	The format of this data structure. If this is a Control, Bulk or Interrupt endpoint, then Format = 0. If this is an Isochronous endpoint, then Format = 1.	
FunctionAddress[6:0]	R	This is the USB address of the function containing the endpoint that this PTD refers to.	

9.4 HC's internal FIFO buffer RAM structure

9.4.1 Partitions

According to the *Universal Serial Bus Specification Rev. 2.0*, there are four types of USB data transfers: Control, Bulk, Interrupt and Isochronous.

The HC's internal FIFO buffer RAM has a physical size of 4 kbytes. This internal FIFO buffer RAM is used for transferring data between the microprocessor and USB peripheral devices. This on-chip buffer RAM can be partitioned into two areas: Acknowledged Transfer List (ATL) buffer and Isochronous (ISO) Transfer List (ITL) buffer. The ITL buffer is a Ping-Pong structured FIFO buffer RAM that is used to keep the payload data and their PTD header for Isochronous transfers. The ATL buffer is a non Ping-Pong structured FIFO buffer RAM that is used for the other three types of transfers.

The ITL buffer can be further partitioned into ITL0 and ITL1 for the Ping-Pong structure. The ITL0 and ITL1 buffers always have the same size. The microprocessor can put ISO data into either the ITL0 buffer or the ITL1 buffer. When the microprocessor accesses an ITL buffer, the HC can take over the other ITL buffer at the same time. This architecture improves the ISO transfer performance.

The HCD can assign the logical size for the ATL buffer and ITL buffers at any time, but normally at initialization after power-on reset. This is done by setting the HcATLBufferLength register (2BH to read, ABH to write) and the HcITLBufferLength register (2AH to read, AAH to write), respectively. The total length (ATL buffer + ITL buffer) should not exceed the maximum RAM size of 4 kbytes. [Figure 17](#) shows the partitions of the internal FIFO buffer RAM. When assigning buffer RAM sizes, follow this formula:

$$\text{ATL buffer length} + 2 \times (\text{ITL buffer size}) \leq 1000\text{H (that is, 4 kbytes)}$$

where: ITL buffer size = ITL0 buffer length = ITL1 buffer length

The following assignments are examples of legal uses of the internal FIFO buffer RAM:

- ATL buffer length = 800H, ITL buffer length = 400H. This is the maximum use of the internal FIFO buffer RAM.
- ATL buffer length = 400H, ITL buffer length = 200H. This is insufficient use of the internal FIFO buffer RAM.

- ATL buffer length = 1000H, ITL buffer length = 0H. This will use the internal FIFO buffer RAM for only ATL transfers.

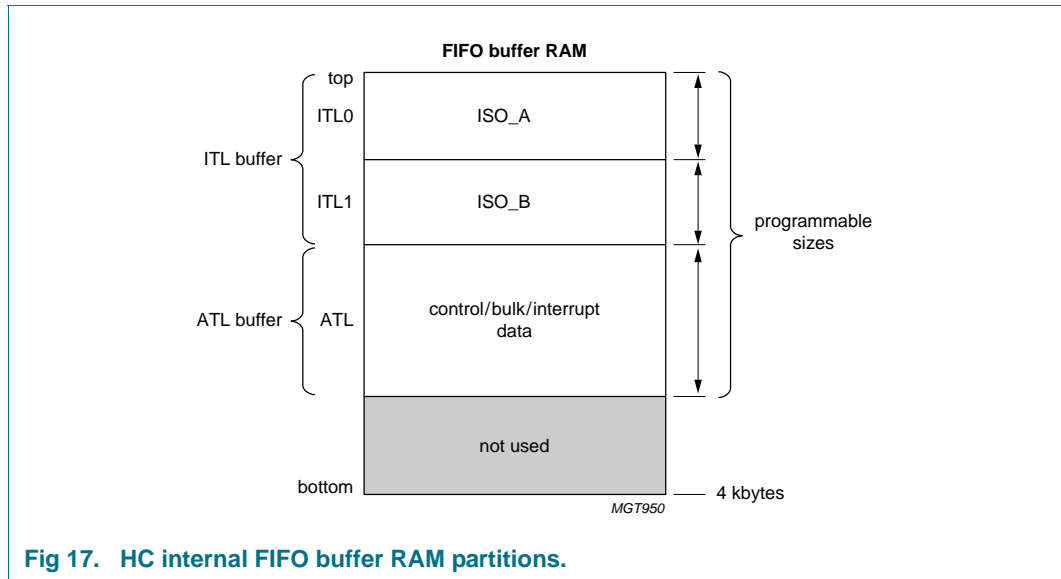

Fig 17. HC internal FIFO buffer RAM partitions.

The actual requirement for the buffer RAM needs to reach not the maximum size. You can make your selection based on your application.

The following are some calculations of the ISO_A or ISO_B space for a frame of data:

- Maximum number of useful data sent during one USB frame is 1280 bytes (20 ISO packets of 64 bytes). The total RAM size needed is:
 $20 \times 8 + 1280 = 1440$ bytes.
- Maximum number of packets for different endpoints sent during one USB frame is 150 (150 ISO packets of 1 byte). The total RAM size needed is:
 $150 \times 8 + 150 \times 1 = 1350$ bytes.
- The Ping buffer RAM (ITL0) and the Pong buffer RAM (ITL1) have a maximum size of 2 kbytes each. All data needed for one frame can be stored in the Ping or the Pong buffer RAM.

When the embedded system wants to initiate a transfer to the USB bus, the data needed for one frame is transferred to the ATL buffer or the ITL buffer. The microprocessor detects the buffer status through interrupt routines. When the HcBufferStatus register (2CH to read only) indicates that the buffer is empty, then the microprocessor writes data into the buffer. When the HcBufferStatus register indicates that the buffer is full, the data is ready on the buffer, and the microprocessor needs to read data from the buffer.

For every 1 ms, there might be many events to generate interrupt requests to the microprocessor for data transfer or status retrieval. However, each of the interrupt types defined in this specification can be enabled or disabled by setting HcμPInterruptEnable register bits accordingly.

The data transfer can be done via the PIO mode or the DMA mode. The data transfer rate can go up to 15 Mbyte/s. In the DMA operation, the single-cycle or multi-cycle burst modes are supported. Multi-cycle burst modes of 1, 4 or 8 cycles per burst are supported for the ISP1160/01.

9.4.2 Data organization

PTD data is used for every data transfer between a microprocessor and the USB bus, and the PTD data resides in the buffer RAM. For an OUT or SETUP transfer, the payload data is placed just after the PTD, after which the next PTD is placed. For an IN transfer, RAM space is reserved for receiving a number of bytes that is equal to the total bytes of the transfer. After this, the next PTD and its payload data are placed (see [Figure 18](#)).

Remark: The PTD is defined for both the ATL and ITL type data transfer. For ITL, the PTD data is put into ITL buffer RAM, and the ISP1160/01 takes care of the Ping-Pong action for the ITL buffer RAM access.

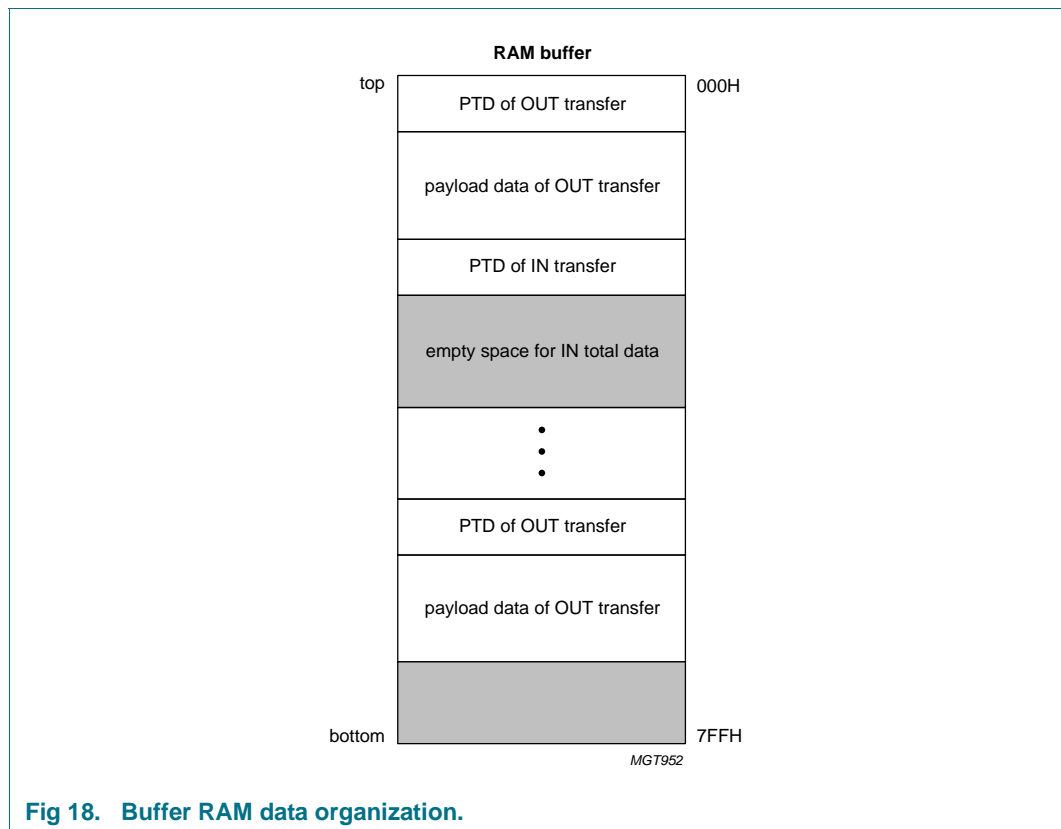

Fig 18. Buffer RAM data organization.

The PTD data (PTD header and its payload data) is a structure of DWORD alignment. This means that the memory address is organized in blocks of 4 bytes. Therefore, the first byte of every PTD and the first byte of every payload data are located at an address that is a multiple of 4. [Figure 19](#) illustrates an example in which the first payload data is 14 bytes long, meaning that the last byte of the payload data is at the location 15H. The next addresses (16H and 17H) are not multiples of 4. Therefore, the first byte of the next PTD will be located at the next multiple-of-four address (18H).

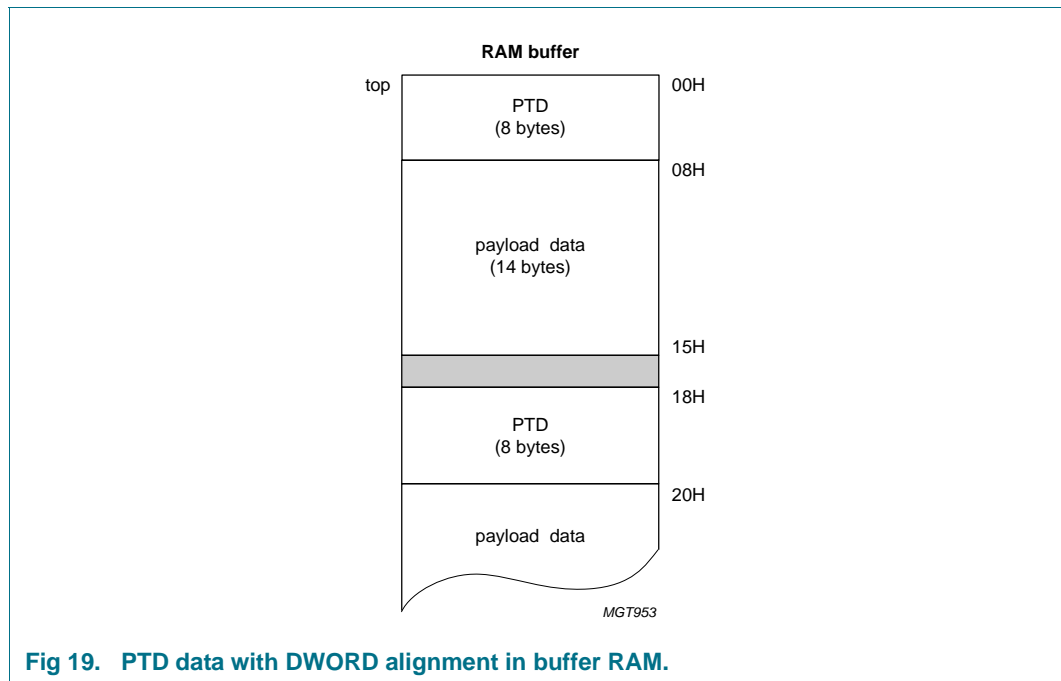

Fig 19. PTB data with DWORD alignment in buffer RAM.

9.4.3 Operation and C program example

[Figure 20](#) shows the block diagram for internal FIFO buffer RAM operations in the PIO mode. The ISP1160/01 provides one register as the access port for each buffer RAM. For the ITL buffer RAM, the access port is the ITLBufferPort register (40H to read, C0H to write). For the ATL buffer RAM, the access port is the ATLBufferPort register (41H to read, C1H to write). The buffer RAM is an array of bytes (8 bits) while the access port is a 16-bit register. Therefore, each read/write operation on the port accesses two consecutive memory locations, incrementing the pointer of the internal buffer RAM by two.

The lower byte of the access port register corresponds to the data byte at the even location of the buffer RAM, and the upper byte corresponds to the next data byte at the odd location of the buffer RAM. Regardless of the number of data bytes to be transferred, the command code must be issued merely once, and it will be followed by a number of accesses of the data port (see [Section 8.4](#)).

When the pointer of the buffer RAM reaches the value of the HcTransferCounter register, an internal EOT signal will be generated to set bit 2, AllEOTInterrupt, of the HcμPInterrupt register and update the HcBufferStatus register, to indicate that the whole data transfer has been completed.

For ITL buffer RAM, every start of frame (SOF) signal (1 ms) will cause toggling between ITL0 and ITL1 but this depends on the buffer status. If both ITL0BufferFull and ITL1BufferFull of the HcBufferStatus register are already logic 1, meaning that both ITL0 and ITL1 buffer RAMs are full, the toggling will not happen. In this case, the microprocessor will always have access to ITL1.

```
//The example program for writing ATL buffer RAM
#include <conio.h>
#include <stdio.h>
#include <dos.h>

//Define register commands
#define wHcTransferCounter 0x22
#define wHcuPIInterrupt 0x24
#define wHcATLBufferLength 0x2b
#define wHcBufferStatus 0x2c

// Define I/O Port Address for HC
#define HcDataPort 0x290
#define HcCmdPort 0x292

//Declare external functions to be used
unsigned int HcRegRead(unsigned int wIndex);
void HcRegWrite(unsigned int wIndex,unsigned int wValue);

void main(void)
{
    unsigned int i;
        unsigned int wCount,wData;

// Prepare PTD data to be written into HC ATL buffer RAM:
    unsigned int PTDData[0x28]=
    {

0x0800,0x1010,0x0810,0x0005, //PTD header for IN token #1

//Reserved space for payload data of IN token #1
0x0000,0x0000,0x0000,0x0000, 0x0000,0x0000,0x0000,0x0000,

0x0800,0x1008,0x0808,0x0005, //PTD header for IN token #2

//Reserved space for payload data of IN token #2
0x0000,0x0000,0x0000,0x0000,

0x0800,0x1010,0x0410,0x0005, //PTD header for OUT token #1

0x0100,0x0302,0x0504,0x0706, //Payload data for OUT token #1
    0x0908,0x0b0a,0x0d0c,0x0f0e,

0x0800,0x1808,0x0408,0x0005, //PTD header for OUT token #2

0x0200,0x0604,0x0a08,0x0e0c //Payload data for OUT token #2
    };
};
```

```

HcRegWrite(wHcuPIInterrupt,0x04); //Clear EOT interrupt bit
    //HcRegWrite(wHcITLBufferLength,0x0);
    HcRegWrite(wHcATLBufferLength,0x1000); //RAM full use for ATL
    //Set the number of bytes to be transferred
    HcRegWrite(wHcTransferCounter,0x50);

wCount = 0x28; //Get word count output
(HcCmdPort,0x00c1); //Command for ATL buffer write

//write 80 (0x50) bytes of data into ATL buffer RAM
for (i=0;i<wCount;i++)
{
    outport(HcDataPort,PTDData[i]);
};

//Check EOT interrupt bit
wData = HcRegRead(wHcuPIInterrupt);
printf("\n HC Interrupt Status = %xH.\n",wData);

//Check Buffer status register
wData = HcRegRead(wHcBufferStatus);
printf("\n HC Buffer Status = %xH.\n",wData);
}

//
// Read HC 16-bit registers
//
unsigned int HcRegRead(unsigned int wIndex)
{ unsigned int wValue;

    outport(HcCmdPort,wIndex & 0x7f);
    wValue = inport(HcDataPort);

    return(wValue);

}

//
// Write HC 16-bit registers
//
void HcRegWrite(unsigned int wIndex,unsigned int wValue)
{
    outport(HcCmdPort,wIndex | 0x80);
    outport(HcDataPort,wValue);
}

```

Table 6. Run results of the C program example

Observed items	HC not initialized and not in USBOperational state	HC initialized and in USBOperational state	Comments
HcμPIInterrupt register			
Bit 1 (ATLInt)	0	1	microprocessor must read ATL
Bit 2 (AllEOTInterrupt)	1	1	transfer completed

Table 6. Run results of the C program example ...continued

Observed items	HC not initialized and not in USBOperational state	HC initialized and in USBOperational state	Comments
HcBufferStatus register			
Bit 2 (ATLBufferFull)	1	1	transfer completed
Bit 5 (ATLBufferDone)	0	1	PTD data processed by HC
USB traffic on USB Bus	no	yes	OUT packets can be seen

9.5 HC operational model

Upon power up, the HCD sets up all operational registers (32-bit). The FSLargestDataPacket field (bits 30 to 16) of the HcFmInterval register (0DH to read, 8DH to write) and the HcLSThreshold register (11H to read, 91H to write) determine the end of the frame for full-speed and low-speed packets. By programming these fields, the effective USB bus usage can be changed. Furthermore, the size of the ITL buffers (HcITLBufferLength, 2AH to read, AAH to write) is programmed.

If a USB frame contains both ISO and AT packets, two interrupts will be generated per frame.

One interrupt is issued concurrently with the SOF. This interrupt (ITLInt is set in the HcμPInterrupt register) triggers reading and writing of the ITL buffer by the microprocessor, after which the interrupt is cleared by the microprocessor.

Next the programmable ATL Interrupt (bit ATLInt is set in the HcμPInterrupt register) is issued, which triggers reading and writing of the ATL buffer by the microprocessor, after which the interrupt is cleared by the microprocessor. If the microprocessor cannot handle the ISO interrupt before the next ISO interrupt, disrupted ISO traffic can result.

To be able to send more than one packet to the same Control or Bulk endpoint in the same frame, the Active bit and the TotalBytes field are introduced (see [Table 5](#)). Bit Active is cleared only if all data of the Proprietary Transfer Descriptor (PTD) have been transferred or if a transaction at that endpoint contained a fatal error. If all PTDs of the ATL are serviced once and the frame is not over yet, the HC starts looking for a PTD with bit Active still set. If such a PTD is found and there is still enough time in this frame, another transaction is started on the USB bus for this endpoint.

For ISO processing, the HCD also has to take care of the BufferStatus register (2CH, read only) for the ITL buffer RAM operations. After the HCD writes ISO data into ITL buffer RAM, the ITL0BufferFull or ITL1BufferFull bit (depending on whether it is ITL0 or ITL1) will be set to logic 1.

After the HC processes the ISO data in the ITL buffer RAM, the corresponding ITL0BufferDone or ITL1BufferDone bit will automatically be set to logic 1.

The HCD can clear the buffer status bits by a read of the ITL buffer RAM. This must be done within the 1 ms frame from which ITL0BufferDone or ITL1BufferDone was set. Failure to do so will cause the ISO processing to stop and a power-on reset or software reset will have to be applied to the HC, a USB reset to the USB bus must **not** be made.

For example, the HCD writes ISO_A data into the ITL0 buffer in the first frame. This will cause the HcBufferStatus register to show that the ITL0 buffer is full by setting bit ITL0BufferFull to logic 1. At this stage, the HCD cannot write ISO data into the ITL0 buffer RAM again.

In the second frame, the HC will process the ISO_A data in the ITL0 buffer. At the same time, the HCD can write ISO_B data into the ITL1 buffer. When the next SOF comes (the beginning of the third frame), both ITL1BufferFull and ITL0BufferDone are automatically set to logic 1.

In the third frame, the HCD has to read at least two bytes (one word) of the ITL0 buffer to clear **both** the ITL0BufferFull and ITL0BufferDone bits. If both are not cleared, when the next SOF comes (the beginning of the fourth frame) the ITL0BufferDone and ITL0BufferFull bits will be cleared automatically. This also applies to the ITL1 buffer because ITL0 and ITL1 are Ping-Pong structured buffers. To recover from this state, a power-on reset or software reset will have to be applied.

9.5.1 Time domain behavior

In example 1 (Figure 21), the CPU is fast enough to read back and download a scenario before the next interrupt. Note that on the ISO interrupt of frame N:

- The ISO packet for frame N + 1 will be written
- The AT packet for frame N + 1 will be written.

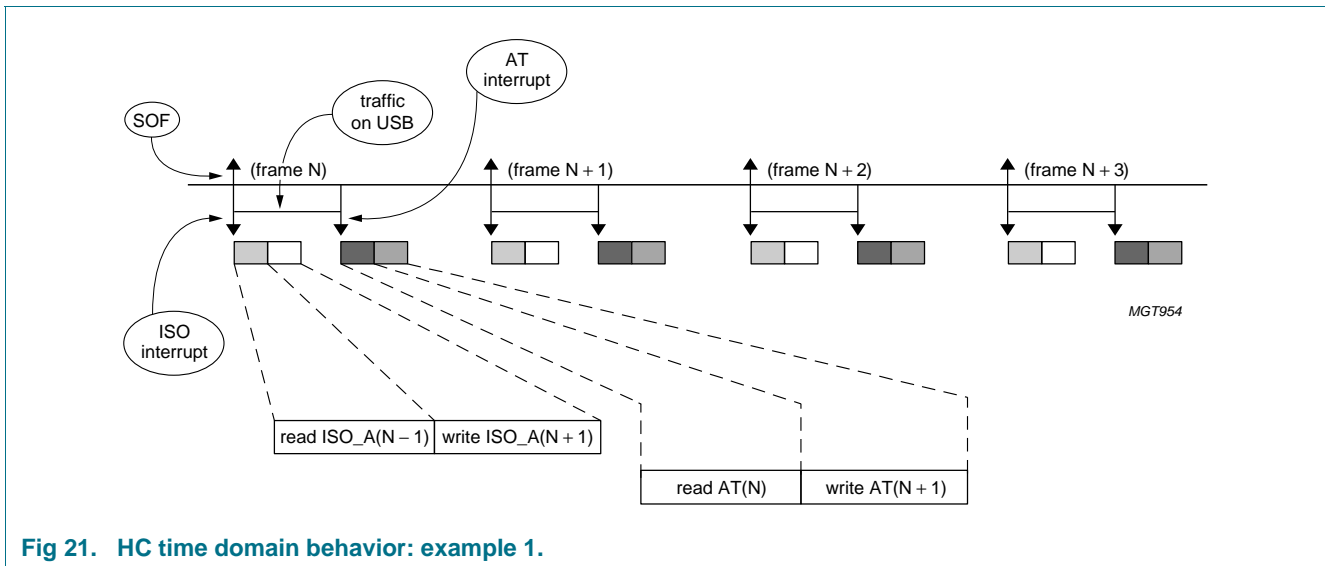

Fig 21. HC time domain behavior: example 1.

In example 2 (Figure 22), the microprocessor is still busy transferring the AT data when the ISO interrupt of the next frame (N + 1) is raised. As a result, there will be no AT traffic in frame N + 1. The HC does not raise an AT interrupt in frame N + 1. The AT part is simply postponed until frame N + 2. On the AT N + 2 interrupt, the transfer mechanism is back to the normal operation. This simple mechanism ensures, among other things, that Control transfers are not dropped systematically from the USB in case of an overloaded microprocessor.

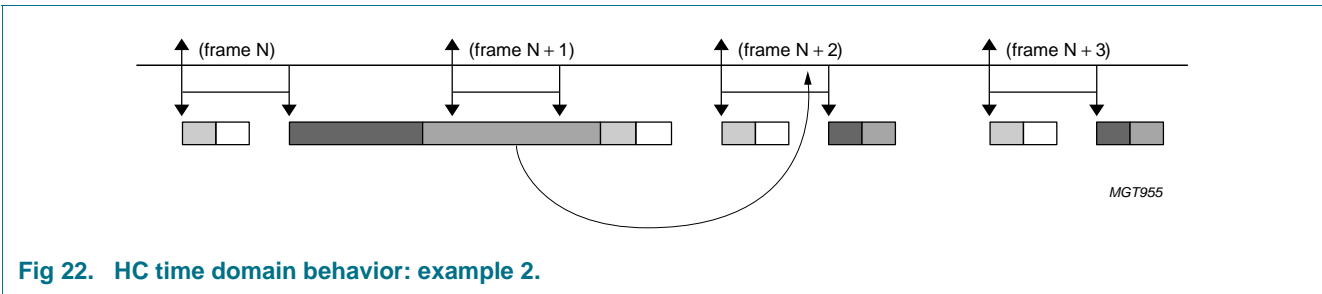

Fig 22. HC time domain behavior: example 2.

In example 3 (Figure 23), the ISO part is still being written while the Start of Frame (SOF) of the next frame has occurred. This will result in undefined behavior for the ISO data on the USB bus in frame N + 1 (depending on whether the exact timing data is corrupted or not). The HC should not raise an AT interrupt in frame N + 1.

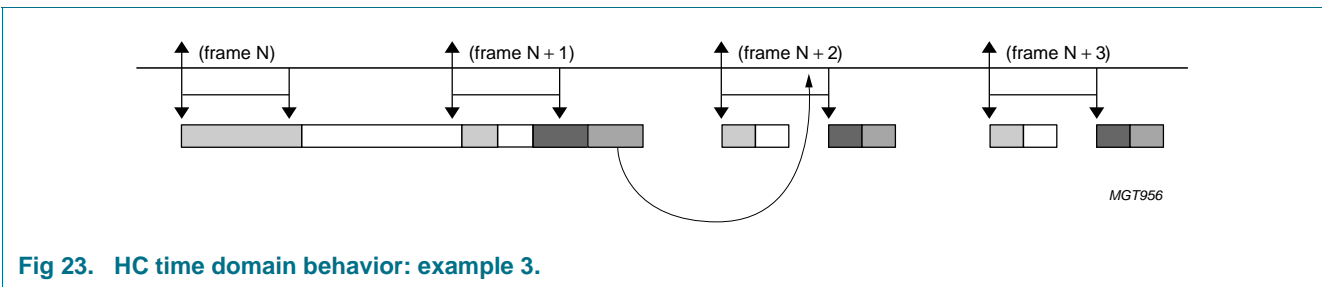

Fig 23. HC time domain behavior: example 3.

9.5.2 Control transaction limitations

The different phases of a Control transfer (SETUP, Data and Status) should never be put in the same ATL.

9.6 Microprocessor loading

The maximum amount of data that can be transferred for an endpoint in one frame is 1023 bytes. The number of USB packets that are needed for this batch of data depends on the maximum packet size that is specified.

The HCD has to schedule the transactions in a frame. On the other hand, the microprocessor must have the ability to handle the interrupts coming from the HC every 1 ms. It must also be able to do the scheduling for the next frame, reading the frame information from and writing the next frame information to the buffer RAM in the time between the end of the current frame and the start of the next frame.

9.7 Internal pull-down resistors for downstream ports

There are four internal 15 kΩ pull-down resistors built in the ISP1160/01 for the two downstream ports: two resistors for each port. These resistors are software selectable by programming bit 12 (2_DownstreamPort15KresistorSel) of the HcHardwareConfiguration register (20H to read, A0H to write). When bit 12 is logic 0, external 15 kΩ pull-down resistors are used. When bit 12 is logic 1, internal 15 kΩ pull-down resistors are used. See Figure 24.

This feature is a cost-saving option. However, the power-on reset default value of bit 12 is logic 0. If using the internal resistors, the HCD must check this bit status after every reset, because a reset action (hardware or software) will clear this bit.

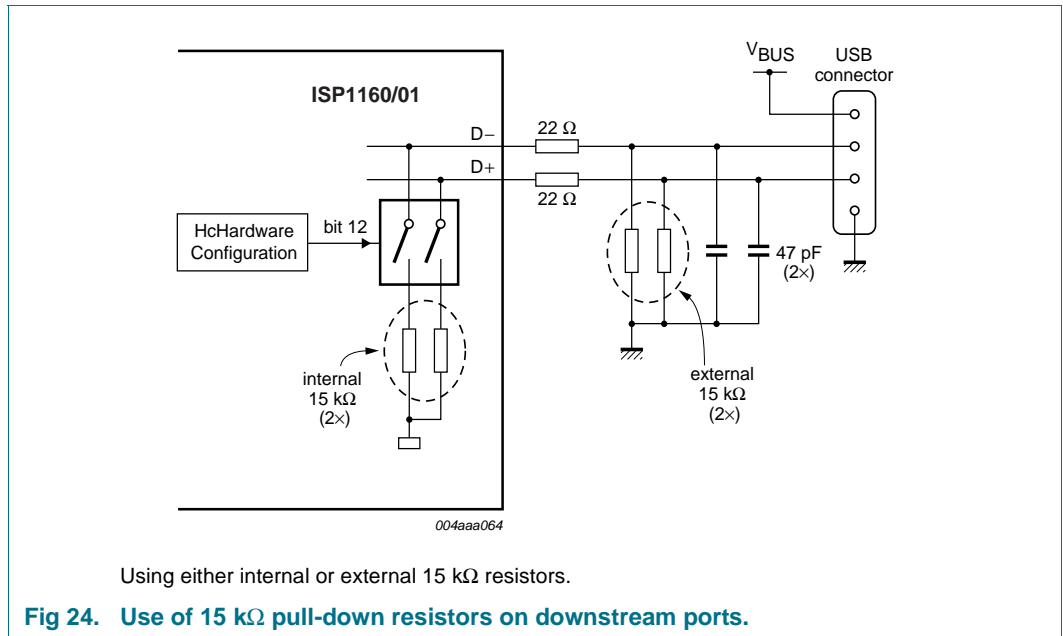

9.8 Overcurrent detection and power switching control

A downstream port provides 5 V power supply to V_{BUS}. The ISP1160/01 has built-in hardware functions to monitor the downstream ports loading conditions and control their power switching. These hardware functions are implemented by the internal power switching control circuit and overcurrent detection circuit. H_PSW1_N and H_PSW2_N are power switching control output pins (active LOW, open-drain) for downstream ports 1 and 2, respectively. H_OC1_N and H_OC2_N are overcurrent detection input pins for downstream ports 1 and 2, respectively.

Figure 25 shows the ISP1160/01 downstream port power management scheme.

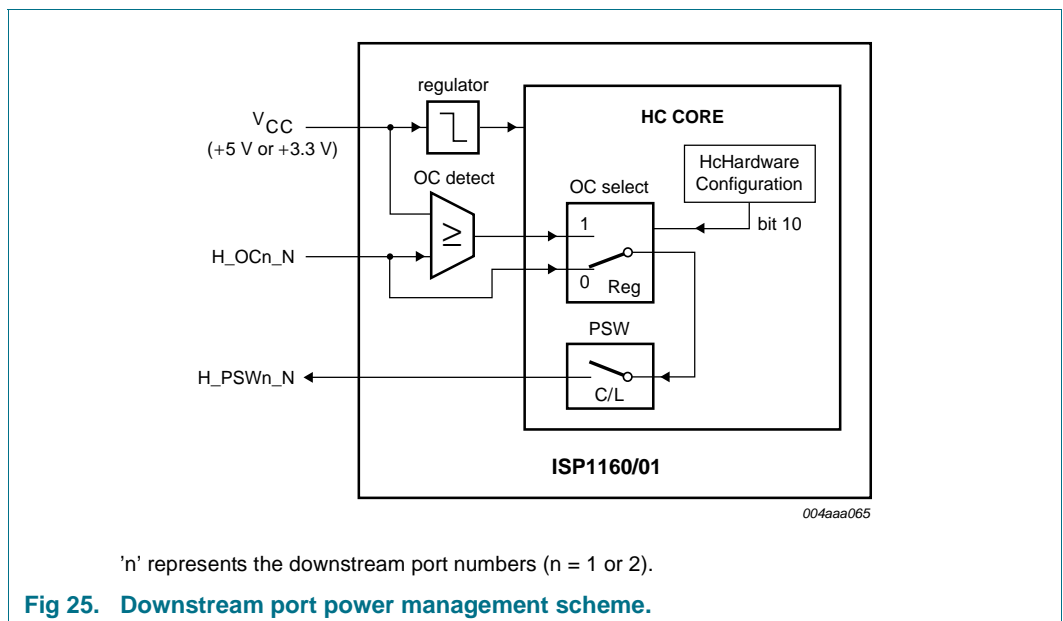

9.8.1 Using an internal OC detection circuit

The internal OC detection circuit can be used only when V_{CC} (pin 56) is connected to a 5 V power supply. The HCD must set AnalogOCEnable, bit 10 of the HcHardwareConfiguration register, to logic 1.

An application using the internal OC detection circuit and internal 15 kΩ pull-down resistors is shown in Figure 26. In this example, the HCD must set both AnalogOCEnable and DownstreamPort15Kresistorssel to logic 1. They are bit 10 and bit 12 of the HcHardwareConfiguration register, respectively.

When H_OCn_N detects an overcurrent status on a downstream port, H_PSWn_N will output HIGH, a logic 1 to turn off the 5 V power supply to the downstream port V_{BUS} . When there is no such detection, H_PSWn_N will output LOW, a logic 0 to turn on the 5 V power supply to the downstream port V_{BUS} .

In general applications, a P-channel MOSFET can be used as the power switch for V_{BUS} . Connect the 5 V power supply to the source of the P-channel MOSFET, V_{BUS} to the drain, and H_PSWn_N to the gate. Call the voltage drop across the drain and source, the overcurrent detection voltage (V_{OC}). For the internal overcurrent detection circuit, a voltage comparator has been designed-in, with a nominal voltage threshold (ΔV_{trip}) of 75 mV. When V_{OC} exceeds V_{trip} , H_PSWn_N will output a HIGH level, logic 1 to turn off the P-channel MOSFET. If the P-channel MOSFET has a R_{DSon} of 150 mΩ, the overcurrent threshold will be 500 mA. The selection of a P-channel MOSFET with a different R_{DSon} will result in a different overcurrent threshold.

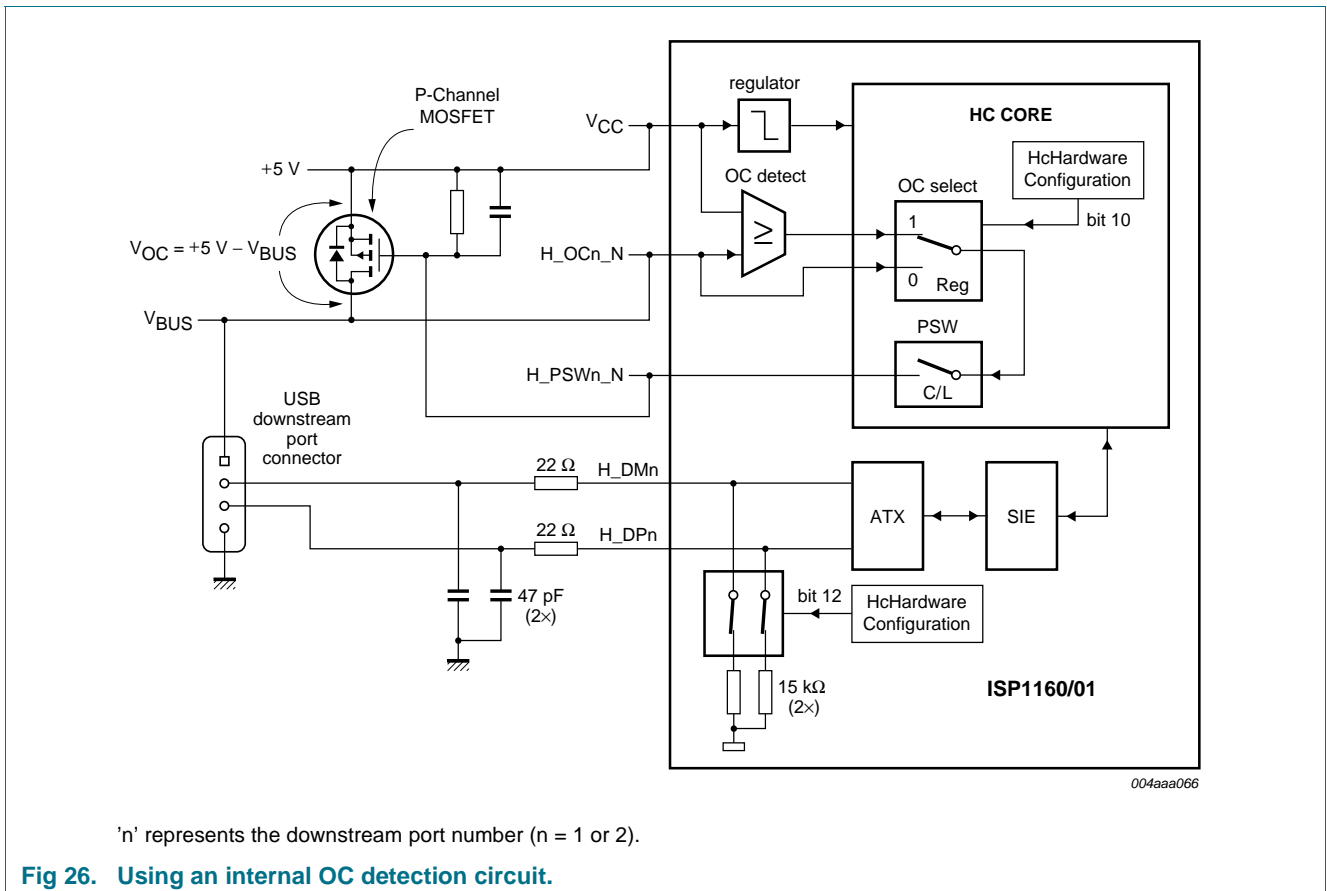

'n' represents the downstream port number (n = 1 or 2).

Fig 26. Using an internal OC detection circuit.

9.8.2 Using an external OC detection circuit

When V_{CC} (pin 56) is connected to a 3.3 V instead of the 5 V power supply, the internal OC detection circuit cannot be used. An external OC detection circuit must be used instead. Regardless of the V_{CC} value, an external OC detection circuit can always be used. To use an external OC detection circuit, AnalogOCEnable, bit 10 of the HcHardwareConfiguration register, should be logic 0. By default after reset, this bit is already logic 0; therefore, the HCD does not need to clear this bit.

Figure 27 shows how to use an external OC detection circuit.

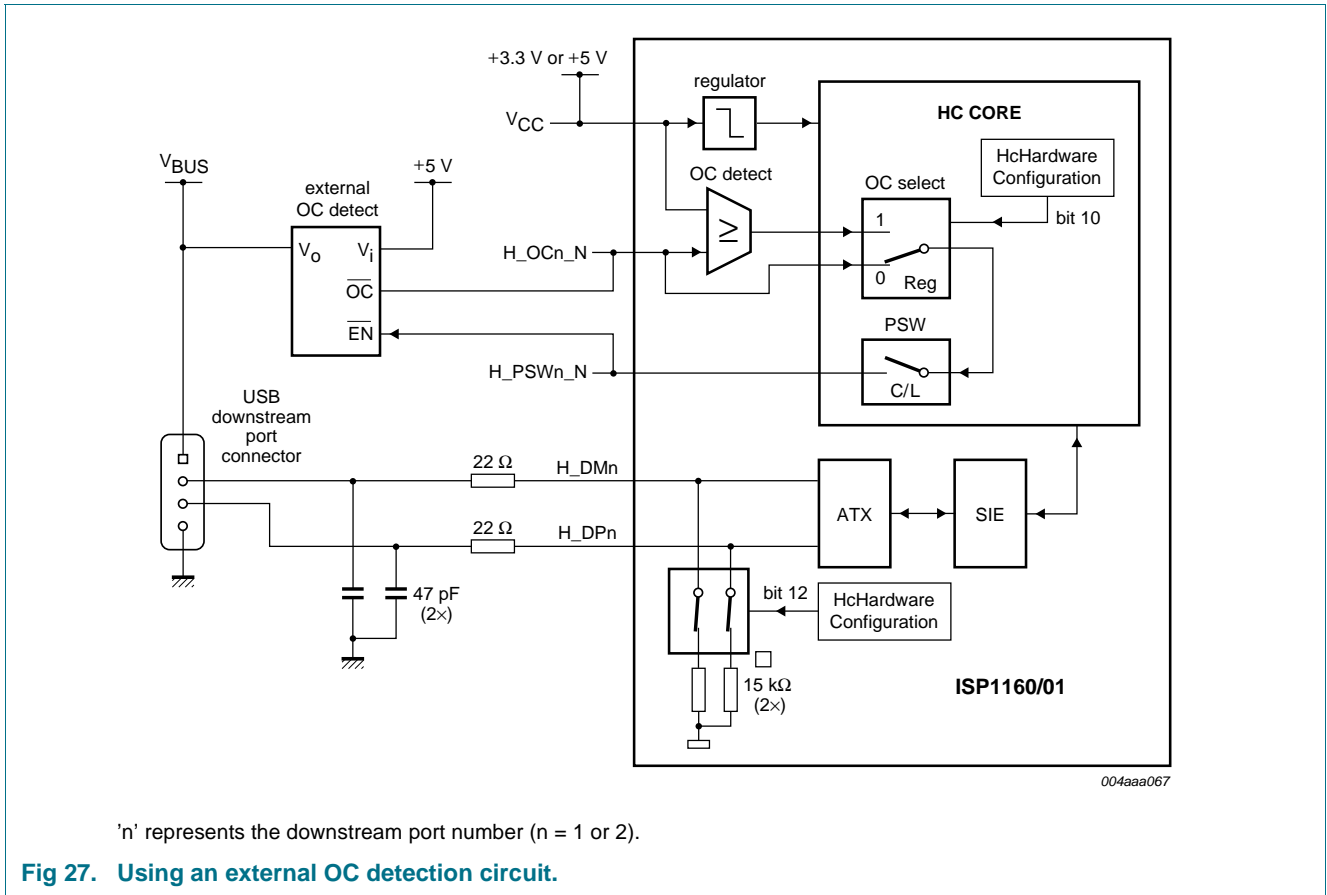

'n' represents the downstream port number (n = 1 or 2).

Fig 27. Using an external OC detection circuit.

9.9 Suspend and wake-up

9.9.1 HC suspended state

The HC can be put into suspended state by setting the HcControl register (01H to read, 81H to write). See Figure 14 for the HC's flow of USB state changes.

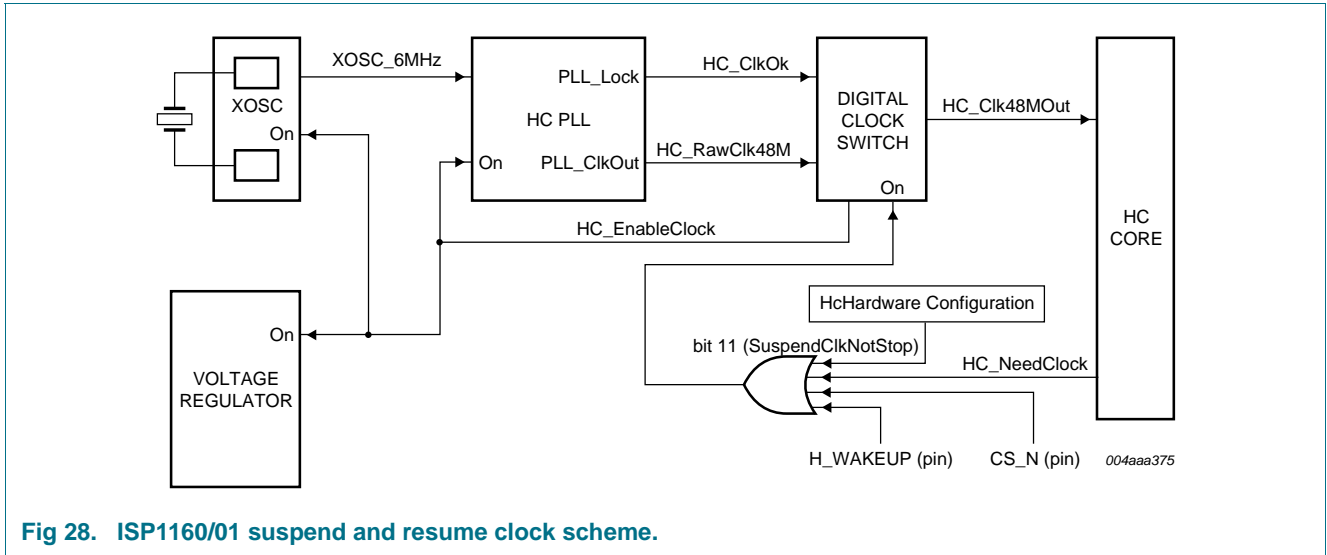

Fig 28. ISP1160/01 suspend and resume clock scheme.

In the suspended state, the device will consume considerably less power by turning off the internal 48 MHz clock, PLL and crystal, and setting the internal regulator to power-down mode. The ISP1160/01 suspend and resume clock scheme is shown in [Figure 28](#).

Pin H_SUSPEND is the sensing output pin for the HC’s suspended state. When the HC goes into the USBSuspend state, this pin will output a HIGH level (logic 1). This pin is cleared to LOW (logic 0) level only when the HC is put into a USBReset state or USBOperational state (refer to the HcControl register bits 7 to 6; 01H to read, 81H to write). Bit 11, SuspendClkNotStop, of the HcHardwareConfiguration register (20H to read, A0H to write), defines if the HC internal clock is stopped or kept running when the HC goes into the USBSuspend state. After the HC enters the USBSuspend state for 1.3 ms, the internal clock will be stopped if bit SuspendClkNotStop is logic 0.

For details on power consumption, refer to ST-NXP Wireless Application Note AN10022 *ISP1160x Low Power Consumption*.

9.9.2 HC wake-up from suspended state

There are three methods to wake up the HC from the USBSuspend state: hardware wake-up, software wake-up, and USB bus resume. They are described as follows.

9.9.2.1 Wake-up by pin H_WAKEUP

Pins H_SUSPEND and H_WAKEUP provide hardware wake-up, a way of remote wake-up control for the HC without the need to access the HC internal registers. H_WAKEUP is an external wake-up control input pin for the HC. After the HC goes into the USBSuspend state, it can be woken up by sending a HIGH level pulse to pin H_WAKEUP. This will turn on the HC’s internal clock, and set bit 6, ClkReady, of the HcμPInterrupt register (24H to read, A4H to write). Under the USBSuspend state, once pin H_WAKEUP goes HIGH, after 160 μs, the internal clock will be up. If pin H_WAKEUP continues to be HIGH, then the internal clock will be kept running, and the microprocessor can set the HC into USBOperational state during this time. If H_WAKEUP goes LOW for more than 1.14 ms, the internal clock stops and the HC goes back into the USBSuspend state.

9.9.2.2 Wake-up by pin CS_N (software wake-up)

During the USBSuspend state, an external microprocessor issues a chip select signal through pin CS_N to the ISP1160/01. This method of access to the ISP1160/01 internal registers is a software wake-up.

9.9.2.3 Wake-up by USB devices

For the USB bus resume, a USB device attached to the root hub port issues a resume signal to the HC through the USB bus, switching the HC from the USBSuspend state to the USBResume state. This will also set bit ResumeDetected of the HcInterruptStatus register (03H to read, 83H to write).

No matter which method is used to wake up the HC from the USBSuspend state, the corresponding interrupt bits must be enabled before the HC goes into the USBSuspend state so that the microprocessor can receive the correct interrupt request to wake up the HC.

10. HC registers

The HC contains a set of on-chip control registers. These registers can be read or written by the Host Controller Driver (HCD). The Control and Status register sets, Frame Counter register sets, and Root Hub register sets are grouped under the category of HC Operational registers (32 bits). These operational registers are made compatible to OpenHCI (Host Controller Interface) operational registers. This allows the OpenHCI HCD to be easily ported to the ISP1160/01.

Reserved bits may be defined in future releases of this specification. To ensure interoperability, the HCD must not assume that a reserved field contains logic 0. Furthermore, the HCD must always preserve the values of the reserved field. When a R/W register is modified, the HCD must first read the register, modify the bits desired, and then write the register with the reserved bits still containing the original value. Alternatively, the HCD can maintain an in-memory copy of previously written values that can be modified and then written to the HC register. When a ‘write to set’ or ‘clear the register’ is performed, bits written to reserved fields must be logic 0.

As shown in [Table 7](#), the addresses (the commands for reading registers) of these 32-bit operational registers are similar to the offsets defined in the OHCI specification with the addresses being equal to offset divided by 4.

Table 7. HC registers summary

Address (Hex)		Register	Width	Reference	Functionality
Read	Write				
00	N/A	HcRevision	32	Section 10.1.1 on page 36	HC control and status registers
01	81	HcControl	32	Section 10.1.2 on page 37	
02	82	HcCommandStatus	32	Section 10.1.3 on page 38	
03	83	HcInterruptStatus	32	Section 10.1.4 on page 39	
04	84	HcInterruptEnable	32	Section 10.1.5 on page 40	
05	85	HcInterruptDisable	32	Section 10.1.6 on page 42	

Table 7. HC registers summary ...continued

Address (Hex)		Register	Width	Reference	Functionality
Read	Write				
0D	8D	HcFmInterval	32	Section 10.2.1 on page 43	HC frame counter registers
0E	N/A	HcFmRemaining	32	Section 10.2.2 on page 44	
0F	N/A	HcFmNumber	32	Section 10.2.3 on page 45	
11	91	HcLSThreshold	32	Section 10.2.4 on page 46	HC Root Hub registers
12	92	HcRhDescriptorA	32	Section 10.3.1 on page 47	
13	93	HcRhDescriptorB	32	Section 10.3.2 on page 48	
14	94	HcRhStatus	32	Section 10.3.3 on page 49	
15	95	HcRhPortStatus[1]	32	Section 10.3.4 on page 51	
16	96	HcRhPortStatus[2]	32	Section 10.3.4 on page 51	
20	A0	HcHardwareConfiguration	16	Section 10.4.1 on page 55	
21	A1	HcDMAConfiguration	16	Section 10.4.2 on page 57	
22	A2	HcTransferCounter	16	Section 10.4.3 on page 57	
24	A4	Hc μ PInterrupt	16	Section 10.4.4 on page 58	
25	A5	Hc μ PInterruptEnable	16	Section 10.4.5 on page 59	HC miscellaneous registers
27	N/A	HcChipID	16	Section 10.5.1 on page 60	
28	A8	HcScratch	16	Section 10.5.2 on page 61	
N/A	A9	HcSoftwareReset	16	Section 10.5.3 on page 61	
2A	AA	HcITLBufferLength	16	Section 10.6.1 on page 62	
2B	AB	HcATLBufferLength	16	Section 10.6.2 on page 62	
2C	N/A	HcBufferStatus	16	Section 10.6.3 on page 63	
2D	N/A	HcReadBackITL0Length	16	Section 10.6.4 on page 64	
2E	N/A	HcReadBackITL1Length	16	Section 10.6.5 on page 64	
40	C0	HcITLBufferPort	16	Section 10.6.6 on page 65	
41	C1	HcATLBufferPort	16	Section 10.6.7 on page 65	

10.1 HC control and status registers

10.1.1 HcRevision register (R: 00H)

Code (Hex): 00 — read only

Table 8. HcRevision register: bit allocation

Bit	31	30	29	28	27	26	25	24
Symbol	reserved							
Reset	0	0	0	0	0	0	0	0
Access	R	R	R	R	R	R	R	R
Bit	23	22	21	20	19	18	17	16
Symbol	reserved							
Reset	0	0	0	0	0	0	0	0
Access	R	R	R	R	R	R	R	R

Bit	15	14	13	12	11	10	9	8
Symbol	reserved							
Reset	0	0	0	0	0	0	0	0
Access	R	R	R	R	R	R	R	R
Bit	7	6	5	4	3	2	1	0
Symbol	REV[7:0]							
Reset	0	0	0	1	0	0	0	0
Access	R	R	R	R	R	R	R	R

Table 9. HcRevision register: bit description

Bit	Symbol	Description
31 to 8	-	reserved
7 to 0	REV[7:0]	Revision: This read-only field contains the BCD representation of the version of the HCI specification that is implemented by this HC. All HC implementations that are compliant with this specification will have a value of 10H.

10.1.2 HcControl register (R/W: 01H/81H)

The HcControl register defines the operating modes of the HC. RemoteWakeupEnable (RWE) is modified only by the HCD.

Code (Hex): 01 — read

Code (Hex): 81 — write

Table 10. HcControl register: bit allocation

Bit	31	30	29	28	27	26	25	24
Symbol	reserved							
Reset	0	0	0	0	0	0	0	0
Access	R/W	R/W	R/W	R/W	R/W	R/W	R/W	R/W
Bit	23	22	21	20	19	18	17	16
Symbol	reserved							
Reset	0	0	0	0	0	0	0	0
Access	R/W	R/W	R/W	R/W	R/W	R/W	R/W	R/W
Bit	15	14	13	12	11	10	9	8
Symbol	reserved					RWE	RWC	reserved
Reset	0	0	0	0	0	0	0	0
Access	R/W	R/W	R/W	R/W	R/W	R/W	R/W	R/W
Bit	7	6	5	4	3	2	1	0
Symbol	HCFS[1:0]		reserved					
Reset	0	0	0	0	0	0	0	0
Access	R/W	R/W	R/W	R/W	R/W	R/W	R/W	R/W

Table 11. HcControl register: bit description

Bit	Symbol	Description
31 to 11	-	reserved
10	RWE	RemoteWakeupEnable: This bit is used by the HCD to enable or disable the remote wake-up feature upon the detection of upstream resume signaling. When this bit is set and the ResumeDetected bit in HcInterruptStatus is set, a remote wake-up is signaled to the host system. Setting this bit has no impact on the generation of hardware interrupt.
9	RWC	RemoteWakeupConnected: This bit indicates whether the HC supports remote wake-up signaling. If remote wake-up is supported and used by the system, it is the responsibility of system firmware to set this bit during POST. The HC clears the bit upon a hardware reset but does not alter it upon a software reset. Remote wake-up signaling of the host system is host-bus-specific and is not described in this specification.
8	-	reserved
7 to 6	HCFS	HostControllerFunctionalState for USB: 00B — USBReset 01B — USBResume 10B — USBOperational 11B — USBSuspend A transition to USBOperational from another state causes start-of-frame (SOF) generation to begin 1 ms later. The HCD may determine whether the HC has begun sending SOFs by reading the StartofFrame field of HcInterruptStatus. This field can be changed by the HC only when in the USBSuspend state. The HC can move from the USBSuspend state to the USBResume state after detecting the resume signaling from a downstream port. The HC enters USBReset after a software reset and a hardware reset. The latter also resets the Root Hub and asserts subsequent reset signaling to downstream ports.
5 to 0	-	reserved

10.1.3 HcCommandStatus register (R/W: 02H/82H)

The HcCommandStatus register is used by the HC to receive commands issued by the HCD, and it also reflects the HC's current status. To the HCD, it appears to be a 'write to set' register. The HC must ensure that bits written as logic 1 become set in the register while bits written as logic 0 remain unchanged in the register. The HCD may issue multiple distinct commands to the HC without concern for corrupting previously issued commands. The HCD has normal read access to all bits.

The SchedulingOverrunCount field indicates the number of frames with which the HC has detected the scheduling overrun error. This occurs when the Periodic list does not complete before EOF. When a scheduling overrun error is detected, the HC increments the counter and sets the SchedulingOverrun field in the HcInterruptStatus register.

Code (Hex): 02 — read

Code (Hex): 82 — write

Table 12. HcCommandStatus register: bit allocation

Bit	31	30	29	28	27	26	25	24
Symbol	reserved							
Reset	0	0	0	0	0	0	0	0
Access	R	R	R	R	R	R	R	R
Bit	23	22	21	20	19	18	17	16
Symbol	reserved						SOC[1:0]	
Reset	0	0	0	0	0	0	0	0
Access	R	R	R	R	R	R	R	R
Bit	15	14	13	12	11	10	9	8
Symbol	reserved							
Reset	0	0	0	0	0	0	0	0
Access	R/W	R/W	R/W	R/W	R/W	R/W	R/W	R/W
Bit	7	6	5	4	3	2	1	0
Symbol	reserved							HCR
Reset	0	0	0	0	0	0	0	0
Access	R/W	R/W	R/W	R/W	R/W	R/W	R/W	R/W

Table 13. HcCommandStatus register: bit description

Bit	Symbol	Description
31 to 18	-	reserved
17 to 16	SOC[1:0]	SchedulingOverrunCount: The field is incremented on each scheduling overrun error. It is initialized to 00B and wraps around at 11B. It will be incremented when a scheduling overrun is detected even if SchedulingOverrun in HcInterruptStatus has already been set. This is used by HCD to monitor any persistent scheduling problems.
15 to 1	-	reserved
0	HCR	HostControllerReset: This bit is set by the HCD to initiate a software reset of the HC. Regardless of the functional state of the HC, it moves to the USBsuspend state in which most of the operational registers are reset, except those stated otherwise, and no Host bus accesses are allowed. This bit is cleared by the HC upon the completion of the reset operation. The reset operation must be completed within 10 μ s. This bit, when set, does not cause a reset to the Root Hub and no subsequent reset signaling should be asserted to its downstream ports.

10.1.4 HcInterruptStatus register (R/W: 03H/83H)

This register provides the status of the events that cause hardware interrupts. When an event occurs, the HC sets the corresponding bit in this register. When a bit is set, a hardware interrupt is generated if the interrupt is enabled in the HcInterruptEnable register (see [Section 10.1.5](#)) and bit MasterInterruptEnable is set. The HCD can clear individual bits in this register by writing logic 1 to the bit positions to be cleared, but cannot set any of these bits. Conversely, the HC can set bits in this register, but cannot clear these bits.

Code (Hex): 03 — read

Code (Hex): 83 — write

Table 14. HcInterruptStatus register: bit allocation

Bit	31	30	29	28	27	26	25	24
Symbol	reserved							
Reset	0	0	0	0	0	0	0	0
Access	R/W	R/W	R/W	R/W	R/W	R/W	R/W	R/W
Bit	23	22	21	20	19	18	17	16
Symbol	reserved							
Reset	0	0	0	0	0	0	0	0
Access	R/W	R/W	R/W	R/W	R/W	R/W	R/W	R/W
Bit	15	14	13	12	11	10	9	8
Symbol	reserved							
Reset	0	0	0	0	0	0	0	0
Access	R/W	R/W	R/W	R/W	R/W	R/W	R/W	R/W
Bit	7	6	5	4	3	2	1	0
Symbol	reserved	RHSC	FNO	UE	RD	SF	reserved	SO
Reset	0	0	0	0	0	0	0	0
Access	R/W	R/W	R/W	R/W	R/W	R/W	R/W	R/W

Table 15. HcInterruptStatus register: bit description

Bit	Symbol	Description
31 to 7	-	reserved
6	RHSC	RootHubStatusChange: This bit is set when the content of HcRhStatus or the content of any of HcRhPortStatus[1:2] has changed.
5	FNO	FrameNumberOverflow: This bit is set when the MSB of HcFmNumber (bit 15) changes value.
4	UE	UnrecoverableError: This bit is set when the HC detects a system error not related to USB. The HC does not proceed with any processing nor signaling before the system error has been corrected. The HCD clears this bit after the HC has been reset. OHCI: Always set to logic 0.
3	RD	ResumeDetected: This bit is set when the HC detects that a device on the USB is asserting resume signaling from a state of no resume signaling. This bit is not set when HCD enters the USBResume state.
2	SF	StartOfFrame: At the start of each frame, this bit is set by the HC and an SOF generated.
1	-	reserved
0	SO	SchedulingOverrun: This bit is set when USB schedules for current frame overruns. A scheduling overrun will also cause the SchedulingOverrunCount of HcCommandStatus to be incremented.

10.1.5 HcInterruptEnable register (R/W: 04H/84H)

Each enable bit in the HcInterruptEnable register corresponds to an associated interrupt bit in the HcInterruptStatus register. The HcInterruptEnable register is used to control which events generate a hardware interrupt. A hardware interrupt is requested on the host bus when three conditions occur:

- A bit is set in the HcInterruptStatus register
- The corresponding bit in the HcInterruptEnable register is set
- Bit MasterInterruptEnable is set.

Writing a logic 1 to a bit in this register sets the corresponding bit, whereas writing a logic 0 to a bit in this register leaves the corresponding bit unchanged. On a read, the current value of this register is returned.

Code (Hex): 04 — read

Code (Hex): 84 — write

Table 16. HcInterruptEnable register: bit allocation

Bit	31	30	29	28	27	26	25	24
Symbol	MIE	reserved						
Reset	0	0	0	0	0	0	0	0
Access	R/W	R/W	R/W	R/W	R/W	R/W	R/W	R/W
Bit	23	22	21	20	19	18	17	16
Symbol	reserved							
Reset	0	0	0	0	0	0	0	0
Access	R/W	R/W	R/W	R/W	R/W	R/W	R/W	R/W
Bit	15	14	13	12	11	10	9	8
Symbol	reserved							
Reset	0	0	0	0	0	0	0	0
Access	R/W	R/W	R/W	R/W	R/W	R/W	R/W	R/W
Bit	7	6	5	4	3	2	1	0
Symbol	reserved	RHSC	FNO	UE	RD	SF	reserved	SO
Reset	0	0	0	0	0	0	0	0
Access	R/W	R/W	R/W	R/W	R/W	R/W	R/W	R/W

Table 17. HcInterruptEnable register: bit description

Bit	Symbol	Description
31	MIE	MasterInterruptEnable by the HCD: A logic 0 is ignored by the HC. A logic 1 enables interrupt generation by events specified in other bits of this register.
30 to 7	-	reserved
6	RHSC	0 — ignore 1 — enable interrupt generation due to Root Hub Status Change
5	FNO	0 — ignore 1 — enable interrupt generation due to frame Number Overflow
4	UE	0 — ignore 1 — enable interrupt generation due to Unrecoverable Error
3	RD	0 — ignore 1 — enable interrupt generation due to Resume Detect

Table 17. HcInterruptEnable register: bit description ...continued

Bit	Symbol	Description
2	SF	0 — ignore 1 — enable interrupt generation due to Start of frame
1	-	reserved
0	SO	0 — ignore 1 — enable interrupt generation due to Scheduling Overrun

10.1.6 HcInterruptDisable register (R/W: 05H/85H)

Each disable bit in the HcInterruptDisable register corresponds to an associated interrupt bit in the HcInterruptStatus register. The HcInterruptDisable register is coupled with the HcInterruptEnable register. Thus, writing a logic 1 to a bit in this register clears the corresponding bit in the HcInterruptEnable register, whereas writing a logic 0 to a bit in this register leaves the corresponding bit in the HcInterruptEnable register unchanged. On a read, the current value of the HcInterruptEnable register is returned.

Code (Hex): 05 — read

Code (Hex): 85 — write

Table 18. HcInterruptDisable register: bit allocation

Bit	31	30	29	28	27	26	25	24
Symbol	MIE	reserved						
Reset	0	0	0	0	0	0	0	0
Access	R/W	R/W	R/W	R/W	R/W	R/W	R/W	R/W
Bit	23	22	21	20	19	18	17	16
Symbol	reserved							
Reset	0	0	0	0	0	0	0	0
Access	R/W	R/W	R/W	R/W	R/W	R/W	R/W	R/W
Bit	15	14	13	12	11	10	9	8
Symbol	reserved							
Reset	0	0	0	0	0	0	0	0
Access	R/W	R/W	R/W	R/W	R/W	R/W	R/W	R/W
Bit	7	6	5	4	3	2	1	0
Symbol	reserved	RHSC	FNO	UE	RD	SF	reserved	SO
Reset	0	0	0	0	0	0	0	0
Access	R/W	R/W	R/W	R/W	R/W	R/W	R/W	R/W

Table 19. HcInterruptDisable register: bit description

Bit	Symbol	Description
31	MIE	A logic 0 is ignored by the HC. A logic 1 disables interrupt generation due to events specified in other bits of this register. This field is set after a hardware or software reset.
30 to 7	-	reserved
6	RHSC	0 — ignore 1 — disable interrupt generation due to Root Hub Status Change

Table 19. HcInterruptDisable register: bit description ...continued

Bit	Symbol	Description
5	FNO	0 — ignore 1 — disable interrupt generation due to Frame Number Overflow
4	UE	0 — ignore 1 — disable interrupt generation due to Unrecoverable Error
3	RD	0 — ignore 1 — disable interrupt generation due to Resume Detect
2	SF	0 — ignore 1 — disable interrupt generation due to Start of Frame
1	-	reserved
0	SO	0 — ignore 1 — disable interrupt generation due to Scheduling Overrun

10.2 HC frame counter registers

10.2.1 HcFmInterval register (R/W: 0DH/8DH)

The HcFmInterval register contains a 14-bit value which indicates the bit time interval in a frame (that is, between two consecutive SOFs), and a 15-bit value indicating the full-speed maximum packet size that the HC may transmit or receive without causing a scheduling overrun. The HCD may carry out minor adjustments on the FrameInterval by writing a new value at each SOF. This allows the HC to synchronize with an external clock resource and to adjust any unknown clock offset.

Code (Hex): 0D — read

Code (Hex): 8D — write

Table 20. HcFmInterval register: bit allocation

Bit	31	30	29	28	27	26	25	24
Symbol	FIT		FSMPS[14:8]					
Reset	0	0	0	0	0	0	0	0
Access	R/W	R/W	R/W	R/W	R/W	R/W	R/W	R/W
Bit	23	22	21	20	19	18	17	16
Symbol	FSMPS[7:0]							
Reset	0	0	0	0	0	0	0	0
Access	R/W	R/W	R/W	R/W	R/W	R/W	R/W	R/W
Bit	15	14	13	12	11	10	9	8
Symbol	reserved		FI[13:8]					
Reset	0	0	1	0	1	1	1	0
Access	R/W	R/W	R/W	R/W	R/W	R/W	R/W	R/W
Bit	7	6	5	4	3	2	1	0
Symbol	FI[7:0]							
Reset	1	1	0	1	1	1	1	1
Access	R/W	R/W	R/W	R/W	R/W	R/W	R/W	R/W

Table 21. HcFmInterval register: bit description

Bit	Symbol	Description
31	FIT	FrameIntervalToggle: The HCD toggles this bit whenever it loads a new value to FrameInterval.
30 to 16	FSMPS [14:0]	FSLargestDataPacket: Specifies a value which is loaded into the Largest Data Packet Counter at the beginning of each frame. The counter value represents the largest amount of data in bits which can be sent or received by the HC in a single transaction at any given time without causing a scheduling overrun. The field value is calculated by the HCD.
15 to 14	-	reserved
13 to 0	FI[13:0]	FrameInterval: Specifies the interval between two consecutive SOFs in bit times. The default value is 11999. The HCD must save the current value of this field before resetting the HC. Setting the HostControllerReset field of the HcCommandStatus register will cause the HC to reset this field to its default value. HCD may choose to restore the saved value upon completing the reset sequence.

10.2.2 HcFmRemaining register (R: 0EH)

The HcFmRemaining register is a 14-bit down counter showing the bit time remaining in the current frame.

Code (Hex): 0E — read

Table 22. HcFmRemaining register: bit allocation

Bit	31	30	29	28	27	26	25	24
Symbol	FRT	reserved						
Reset	0	0	0	0	0	0	0	0
Access	R	R	R	R	R	R	R	R
Bit	23	22	21	20	19	18	17	16
Symbol	reserved							
Reset	0	0	0	0	0	0	0	0
Access	R	R	R	R	R	R	R	R
Bit	15	14	13	12	11	10	9	8
Symbol	reserved		FR[13:8]					
Reset	0	0	0	0	0	0	0	0
Access	R	R	R	R	R	R	R	R
Bit	7	6	5	4	3	2	1	0
Symbol	FR[7:0]							
Reset	0	0	0	0	0	0	0	0
Access	R	R	R	R	R	R	R	R

Table 23. HcFmRemaining register: bit description

Bit	Symbol	Description
31	FRT	FrameRemainingToggle: This bit is loaded from the FrameIntervalToggle field of the HcFmInterval register whenever FrameRemaining reaches 0. This bit is used by the HCD for synchronization between FrameInterval and FrameRemaining.
30 to 14	-	reserved
13 to 0	FR[13:0]	FrameRemaining: This counter is decremented at each bit time. When it reaches zero, it is reset by loading the FrameInterval value specified in the HcFmInterval register at the next bit time boundary. When entering the USBOperational state, the HC reloads it with the content of the FrameInterval part of the HcFmInterval register and uses the updated value from the next SOF.

10.2.3 HcFmNumber register (R: 0FH)

The HcFmNumber register is a 16-bit counter. It provides a timing reference for events happening in the HC and the HCD. The HCD may use the 16-bit value specified in this register and generate a 32-bit frame number without requiring frequent access to the register.

Code (Hex): 0F — read

Table 24. HcFmNumber register: bit allocation

Bit	31	30	29	28	27	26	25	24
Symbol	reserved							
Reset	0	0	0	0	0	0	0	0
Access	R	R	R	R	R	R	R	R
Bit	23	22	21	20	19	18	17	16
Symbol	reserved							
Reset	0	0	0	0	0	0	0	0
Access	R	R	R	R	R	R	R	R
Bit	15	14	13	12	11	10	9	8
Symbol	FN[15:8]							
Reset	0	0	0	0	0	0	0	0
Access	R	R	R	R	R	R	R	R
Bit	7	6	5	4	3	2	1	0
Symbol	FN[7:0]							
Reset	0	0	0	0	0	0	0	0
Access	R	R	R	R	R	R	R	R

Table 25. HcFmNumber register: bit description

Bit	Symbol	Description
31 to 16	-	reserved
15 to 0	FN[15:0]	FrameNumber: This is incremented when HcFmRemaining is reloaded. It rolls over to 0000H after FFFFH. When the USBOperational state is entered, this will be incremented automatically. The HC will set bit StartofFrame in the HcInterruptStatus register.

10.2.4 HcLSThreshold register (R/W: 11H/91H)

The HcLSThreshold register contains an 11-bit value used by the HC to determine whether to commit to the transfer of a maximum of 8-byte LS packet before EOF. Neither the HC nor the HCD is allowed to change this value.

Code (Hex): 11 — read

Code (Hex): 91 — write

Table 26. HcLSThreshold register: bit allocation

Bit	31	30	29	28	27	26	25	24
Symbol	reserved							
Reset	0	0	0	0	0	0	0	0
Access	R/W	R/W	R/W	R/W	R/W	R/W	R/W	R/W
Bit	23	22	21	20	19	18	17	16
Symbol	reserved							
Reset	0	0	0	0	0	0	0	0
Access	R/W	R/W	R/W	R/W	R/W	R/W	R/W	R/W
Bit	15	14	13	12	11	10	9	8
Symbol	reserved					LST[10:8]		
Reset	0	0	0	0	0	1	1	0
Access	R/W	R/W	R/W	R/W	R/W	R/W	R/W	R/W
Bit	7	6	5	4	3	2	1	0
Symbol	LST[7:0]							
Reset	0	0	1	0	1	0	0	0
Access	R/W	R/W	R/W	R/W	R/W	R/W	R/W	R/W

Table 27. HcLSThreshold register: bit description

Bit	Symbol	Description
31 to 11	-	reserved
10 to 0	LST[10:0]	LSThreshold: Contains a value that is compared to the FrameRemaining field before a low-speed transaction is initiated. The transaction is started only if FrameRemaining \geq this field. The value is calculated by the HCD, which considers transmission and set-up overhead.

10.3 HC Root Hub registers

All registers included in this partition are dedicated to the USB Root Hub, which is an integral part of the HC although it is functionally a separate entity. The Host Controller Driver (HCD) emulates USB accesses to the Root Hub via a register interface. The HCD maintains many USB-defined hub features that are not required to be supported in hardware. For example, the Hub's Device, Configuration, Interface, and Endpoint Descriptors, as well as some static fields of the Class Descriptor, are maintained only in the HCD. The HCD also maintains and decodes the Root Hub's device address as well as other minor operations more suited for software than hardware.

The Root Hub registers were developed to match the bit organization and operation of typical hubs found in the system.

Four 32-bit registers have been defined:

- HcRhDescriptorA
- HcRhDescriptorB
- HcRhStatus
- HcRhPortStatus[1:NDP]

Each register is read and written as a DWORD. These registers are only written during initialization to correspond with the system implementation. The HcRhDescriptorA and HcRhDescriptorB registers are writeable regardless of the HC's USB states. HcRhStatus and HcRhPortStatus are writeable during the USBOperational state only.

10.3.1 HcRhDescriptorA register (R/W: 12H/92H)

The HcRhDescriptorA register is the first register of two describing the characteristics of the Root Hub. Reset values are implementation-specific (IS). The descriptor length (11), descriptor type and hub controller current (0) fields of the hub Class Descriptor are emulated by the HCD. All other fields are located in registers HcRhDescriptorA and HcRhDescriptorB.

Remark: IS denotes an implementation-specific reset value for that field.

Code (Hex): 12 — read

Code (Hex): 92 — write

Table 28. HcRhDescriptorA register: bit description

Bit	31	30	29	28	27	26	25	24
Symbol	POTPGT[7:0]							
Reset	IS	IS	IS	IS	IS	IS	IS	IS
Access	R/W	R/W	R/W	R/W	R/W	R/W	R/W	R/W
Bit	23	22	21	20	19	18	17	16
Symbol	reserved							
Reset	0	0	0	0	0	0	0	0
Access	R/W	R/W	R/W	R/W	R/W	R/W	R/W	R/W
Bit	15	14	13	12	11	10	9	8
Symbol	reserved			NOCP	OCPM	DT	NPS	PSM
Reset	0	0	0	IS	IS	0	IS	IS
Access	R	R	R	R/W	R/W	R	R/W	R/W
Bit	7	6	5	4	3	2	1	0
Symbol	reserved						NDP[1:0]	
Reset	0	0	0	0	0	0	IS	IS
Access	R	R	R	R	R	R	R	R

Table 29. HcRhDescriptorA register: bit description

Bit	Symbol	Description
31 to 24	POTPGT [7:0]	PowerOnToPowerGoodTime: This byte specifies the duration HCD has to wait before accessing a powered-on port of the Root Hub. The unit of time is 2 ms. The duration is calculated as POTPGT × 2 ms.
23 to 13	-	reserved
12	NOCP	NoOverCurrentProtection: This bit describes how the overcurrent status for the Root Hub ports are reported. When this bit is cleared, the OverCurrentProtectionMode field specifies global or per-port reporting. 0 — overcurrent status is reported collectively for all downstream ports 1 — no overcurrent reporting supported
11	OCPM	OverCurrentProtectionMode: This bit describes how the overcurrent status for the Root Hub ports is reported. At reset, this field reflects the same mode as PowerSwitchingMode. This field is valid only if the NoOverCurrentProtection field is cleared. 0 — overcurrent status is reported collectively for all downstream ports 1 — overcurrent status is reported on a per-port basis. On power-up, clear this bit and then set it to logic 1.
10	DT	DeviceType: This bit specifies that the Root Hub is not a compound device—it is not permitted. This field should always read/write 0.
9	NPS	NoPowerSwitching: This bit is used to specify whether power switching is supported or ports are always powered. When this bit is cleared, bit PowerSwitchingMode specifies global or per-port switching. 0 — ports are power switched 1 — ports are always powered on when the HC is powered on
8	PSM	PowerSwitchingMode: This bit is used to specify how the power switching of the Root Hub ports is controlled. This field is valid only if the NoPowerSwitching field is cleared. 0 — all ports are powered at the same time 1 — each port is powered individually. This mode allows port power to be controlled by either the global switch or per-port switching. If bit PortPowerControlMask is set, the port responds to only port power commands (Set/ClearPortPower). If the port mask is cleared, then the port is controlled only by the global power switch (Set/ClearGlobalPower).
7 to 2	-	reserved
1 to 0	NDP[1:0]	NumberDownstreamPorts: These bits specify the number of downstream ports supported by the Root Hub. The maximum number of ports supported by the ISP1160/01 is 2.

10.3.2 HcRhDescriptorB register (R/W: 13H/93H)

The HcRhDescriptorB register is the second register of two describing the characteristics of the Root Hub. These fields are written during initialization to correspond with the system implementation. Reset values are implementation-specific (IS).

Code (Hex): 13 — read

Code (Hex): 93 — write

Table 30. HcRhDescriptorB register: bit allocation

Bit	31	30	29	28	27	26	25	24
Symbol	reserved							
Reset	N/A	N/A	N/A	N/A	N/A	N/A	N/A	N/A
Access	R	R	R	R	R	R	R	R
Bit	23	22	21	20	19	18	17	16
Symbol	reserved					PPCM[2:0]		
Reset	N/A	N/A	N/A	N/A	N/A	IS	IS	IS
Access	R	R	R	R	R	R/W	R/W	R/W
Bit	15	14	13	12	11	10	9	8
Symbol	reserved							
Reset	N/A	N/A	N/A	N/A	N/A	N/A	N/A	N/A
Access	R	R	R	R	R	R	R	R
Bit	7	6	5	4	3	2	1	0
Symbol	reserved					DR[2:0]		
Reset	N/A	N/A	N/A	N/A	N/A	IS	IS	IS
Access	R	R	R	R	R	R/W	R/W	R/W

Table 31. HcRhDescriptorB register: bit description

Bit	Symbol	Description
31 to 19	-	reserved
18 to 16	PPCM[2:0]	PortPowerControlMask: Each bit indicates whether a port is affected by a global power control command when PowerSwitchingMode is set. When set, the port's power state is only affected by per-port power control (Set/ClearPortPower). When cleared, the port is controlled by the global power switch (Set/ClearGlobalPower). If the device is configured to global switching mode (PowerSwitchingMode = 0), this field is not valid. Bit 0 — reserved Bit 1 — Ganged-power mask on Port #1 Bit 2 — Ganged-power mask on Port #2
15 to 3	-	reserved
2 to 0	DR[2:0]	DeviceRemovable: Each bit is dedicated to a port of the Root Hub. When cleared, the attached device is removable. When set, the attached device is not removable. Bit 0 — reserved Bit 1 — Device attached to Port #1 Bit 2 — Device attached to Port #2

10.3.3 HcRhStatus register (R/W: 14H/94H)

The HcRhStatus register is divided into two parts. The lower word of a DWORD represents the Hub Status field and the upper word represents the Hub Status Change field. Reserved bits should always be written as logic 0.

Code (Hex): 14 — read

Code (Hex): 94 — write

Table 32. HcRhStatus register: bit allocation

Bit	31	30	29	28	27	26	25	24
Symbol	CRWE	reserved						
Reset	0	0	0	0	0	0	0	0
Access	W	R	R	R	R	R	R	R
Bit	23	22	21	20	19	18	17	16
Symbol	reserved						OCIC	LPSC
Reset	0	0	0	0	0	0	0	0
Access	R	R	R	R	R	R	R/W	R/W
Bit	15	14	13	12	11	10	9	8
Symbol	DRWE	reserved						
Reset	0	0	0	0	0	0	0	0
Access	R/W	R	R	R	R	R	R	R
Bit	7	6	5	4	3	2	1	0
Symbol	reserved						OCI	LPS
Reset	0	0	0	0	0	0	0	0
Access	R	R	R	R	R	R	R	R/W

Table 33. HcRhStatus register: bit description

Bit	Symbol	Description
31	CRWE	On write— ClearRemoteWakeupEnable : Writing a logic 1 clears DeviceRemoveWakeupEnable. Writing a logic 0 has no effect.
30 to 18	-	reserved
17	OCIC	OverCurrentIndicatorChange : This bit is set by hardware when a change has occurred to the OCI field of this register. The HCD clears this bit by writing a logic 1. Writing a logic 0 has no effect.
16	LPSC	On read— LocalPowerStatusChange : The Root Hub does not support the local power status feature. Therefore, this bit is always read as logic 0. On write— SetGlobalPower : In global power mode (PowerSwitchingMode = 0), this bit is written to logic 1 to turn on power to all ports (clear PortPowerStatus). In per-port power mode, it sets PortPowerStatus only on ports whose bit PortPowerControlMask is not set. Writing a logic 0 has no effect.
15	DRWE	On read— DeviceRemoteWakeupEnable : This bit enables the bit ConnectStatusChange as a resume event, causing a state transition USBSuspend to USBResume and setting the ResumeDetected interrupt. 0 — ConnectStatusChange is not a remote wake-up event 1 — ConnectStatusChange is a remote wake-up event On write— SetRemoteWakeupEnable : Writing a logic 1 sets DeviceRemoveWakeupEnable. Writing a logic 0 has no effect.
14 to 2	-	reserved
1	OCI	OverCurrentIndicator : This bit reports overcurrent conditions when global reporting is implemented. When set, an overcurrent condition exists. When clear, all power operations are normal. If per-port overcurrent protection is implemented this bit is always logic 0.
0	LPS	On read— LocalPowerStatus : The Root Hub does not support the local power status feature. Therefore, this bit is always read as logic 0. On write— ClearGlobalPower : In global power mode (PowerSwitchingMode = 0), this bit is written to logic 1 to turn off power to all ports (clear PortPowerStatus). In per-port power mode, it clears PortPowerStatus only on ports whose bit PortPowerControlMask is not set. Writing a logic 0 has no effect.

10.3.4 HcRhPortStatus[1:2] (R/W [1]:15H/95H, [2]: 16H/96H)

The HcRhPortStatus[1:2] register is used to control and report port events on a per-port basis. NumberDownstreamPorts represents the number of HcRhPortStatus registers that are implemented in hardware. The lower word is used to reflect the port status, whereas the upper word reflects the status change bits. Some status bits are implemented with special write behavior. If a transaction (token through handshake) is in progress when a write to change port status occurs, the resulting port status change must be postponed until the transaction completes. Reserved bits should always be written logic 0.

Code (Hex): [1] = 15, [2] = 16 — read

Code (Hex): [1] = 95, [2] = 96 — write

Table 34. HcRhPortStatus[1:2] register: bit allocation

Bit	31	30	29	28	27	26	25	24
Symbol	reserved							
Reset	0	0	0	0	0	0	0	0
Access	R/W	R/W	R/W	R/W	R/W	R/W	R/W	R/W
Bit	23	22	21	20	19	18	17	16
Symbol	reserved			PRSC	OCIC	PSSC	PESC	CSC
Reset	0	0	0	0	0	0	0	0
Access	R/W	R/W	R/W	R/W	R/W	R/W	R/W	R/W
Bit	15	14	13	12	11	10	9	8
Symbol	reserved						LSDA	PPS
Reset	0	0	0	0	0	0	0	0
Access	R/W	R/W	R/W	R/W	R/W	R/W	R/W	R/W
Bit	7	6	5	4	3	2	1	0
Symbol	reserved			PRS	POCI	PSS	PES	CCS
Reset	0	0	0	0	0	0	0	0
Access	R/W	R/W	R/W	R/W	R/W	R/W	R/W	R/W

Table 35. HcRshPortStatus[1:2] register: bit description

Bit	Symbol	Description
31 to 21	-	reserved
20	PRSC	<p>PortResetStatusChange: This bit is set at the end of the 10 ms port reset signal. The HCD writes a logic 1 to clear this bit. Writing a logic 0 has no effect.</p> <p>0 — port reset is not complete 1 — port reset is complete</p>
19	OCIC	<p>PortOverCurrentIndicatorChange: This bit is valid only if overcurrent conditions are reported on a per-port basis. This bit is set when Root Hub changes the PortOverCurrentIndicator bit. The HCD writes a logic 1 to clear this bit. Writing a logic 0 has no effect.</p> <p>0 — no change in PortOverCurrentIndicator 1 — PortOverCurrentIndicator has changed</p>
18	PSSC	<p>PortSuspendStatusChange: This bit is set when the full resume sequence has been completed. This sequence includes the 20 s resume pulse, LS EOP, and 3 ms resynchronization delay. The HCD writes a logic 1 to clear this bit. Writing a logic 0 has no effect. This bit is also cleared when ResetStatusChange is set.</p> <p>0 — resume is not completed 1 — resume is completed</p>
17	PESC	<p>PortEnableStatusChange: This bit is set when hardware events cause the PortEnableStatus bit to be cleared. Changes from HCD writes do not set this bit. The HCD writes a logic 1 to clear this bit. Writing a logic 0 has no effect.</p> <p>0 — no change in PortEnableStatus 1 — change in PortEnableStatus</p>

Table 35. HcRshPortStatus[1:2] register: bit description ...continued

Bit	Symbol	Description
16	CSC	<p>ConnectStatusChange: This bit is set whenever a connect or disconnect event occurs. The HCD writes a logic 1 to clear this bit. Writing a logic 0 has no effect. If CurrentConnectStatus is cleared when a SetPortReset, SetPortEnable, or SetPortSuspend write occurs, this bit is set to force the driver to reevaluate the connection status since these writes should not occur if the port is disconnected.</p> <p>0 — no change in CurrentConnectStatus 1 — change in CurrentConnectStatus</p> <p>Remark: If bit DeviceRemovable[NDP] is set, this bit is set only after a Root Hub reset to inform the system that the device is attached.</p>
15 to 10	-	reserved
9	LSDA	<p>On read—LowSpeedDeviceAttached: This bit indicates the speed of the device connected to this port. When set, a low-speed device is connected to this port. When clear, a full-speed device is connected to this port. This field is valid only when the CurrentConnectStatus is set.</p> <p>0 — full-speed device attached 1 — low-speed device attached</p> <p>On write—ClearPortPower: The HCD clears bit PortPowerStatus by writing a logic 1 to this bit. Writing a logic 0 has no effect.</p>
8	PPS	<p>On read—PortPowerStatus: This bit reflects the port power status, regardless of the type of power switching implemented. This bit is cleared if an overcurrent condition is detected.</p> <p>The HCD sets this bit by writing SetPortPower or SetGlobalPower. The HCD clears this bit by writing ClearPortPower or ClearGlobalPower. Which power control switches are enabled is determined by PowerSwitchingMode.</p> <p>In the global switching mode (PowerSwitchingMode = 0), only Set/ClearGlobalPower controls this bit. In per-port power switching (PowerSwitchingMode = 1), if bit PortPowerControlMask[NDP] for the port is set, only Set/ClearPortPower commands are enabled. If the mask is not set, only Set/ClearGlobalPower commands are enabled.</p> <p>When port power is disabled, CurrentConnectStatus, PortEnableStatus, PortSuspendStatus, and PortResetStatus should be reset.</p> <p>0 — port power is off 1 — port power is on</p> <p>On write—SetPortPower: The HCD writes a logic 1 to set bit PortPowerStatus. Writing a logic 0 has no effect.</p> <p>Remark: This bit always reads logic 1 if power switching is not supported.</p>
7 to 5	-	reserved

Table 35. HcRshPortStatus[1:2] register: bit description ...continued

Bit	Symbol	Description
4	PRS	<p>On read—PortResetStatus: When this bit is set by a write to SetPortReset, port reset signaling is asserted. When reset is completed, this bit is cleared when PortResetStatusChange is set. This bit cannot be set if CurrentConnectStatus is cleared.</p> <p>0 — port reset signal is not active 1 — port reset signal is active</p> <p>On write—SetPortReset: The HCD sets the port reset signaling by writing a logic 1 to this bit. Writing a logic 0 has no effect. If CurrentConnectStatus is cleared, this write does not set PortResetStatus but instead sets ConnectStatusChange. This informs the driver that it attempted to reset a disconnected port.</p>
3	POCI	<p>On read—PortOverCurrentIndicator: This bit is valid only when the Root Hub is configured in such a way that overcurrent conditions are reported on a per-port basis. If per-port overcurrent reporting is not supported, this bit is set to logic 0. If cleared, all power operations are normal for this port. If set, an overcurrent condition exists on this port. This bit always reflects the overcurrent input signal.</p> <p>0 — no overcurrent condition 1 — overcurrent condition detected</p> <p>(write) ClearSuspendStatus: The HCD writes a logic 1 to initiate a resume. Writing a logic 0 has no effect. A resume is initiated only if PortSuspendStatus is set.</p>

Table 35. HcRshPortStatus[1:2] register: bit description ...continued

Bit	Symbol	Description
2	PSS	<p>On read—PortSuspendStatus: This bit indicates whether the port is suspended or in the resume sequence. It is set by a SetSuspendState write and cleared when PortSuspendStatusChange is set at the end of the resume interval. This bit cannot be set if CurrentConnectStatus is cleared. This bit is also cleared when PortResetStatusChange is set at the end of the port reset or when the HC is placed in the USBResume state. If an upstream resume is in progress, it should propagate to the HC.</p> <p>0 — port is not suspended 1 — port is suspended</p> <p>On write—SetPortSuspend: The HCD sets bit PortSuspendStatus by writing a logic 1 to this bit. Writing a logic 0 has no effect. If CurrentConnectStatus is cleared, this write does not set PortSuspendStatus; instead it sets ConnectStatusChange. This informs the driver that it attempted to suspend a disconnected port.</p>
1	PES	<p>On read—PortEnableStatus: This bit indicates whether the port is enabled or disabled. The Root Hub may clear this bit when an overcurrent condition, disconnect event, switched-off power, or operational bus error such as babble is detected. This change also causes PortEnabledStatusChange to be set. The HCD sets this bit by writing SetPortEnable and clears it by writing ClearPortEnable. This bit cannot be set when CurrentConnectStatus is cleared. This bit is also set at the completion of a port reset when ResetStatusChange is set or port is suspended when SuspendStatusChange is set.</p> <p>0 — port is disabled 1 — port is enabled</p> <p>On write—SetPortEnable: The HCD sets PortEnableStatus by writing a logic 1. Writing a logic 0 has no effect. If CurrentConnectStatus is cleared, this write does not set PortEnableStatus, but instead sets ConnectStatusChange. This informs the driver that it attempted to enable a disconnected port.</p>
0	CCS	<p>On read—CurrentConnectStatus: This bit reflects the current state of the downstream port.</p> <p>0 — no device connected 1 — device connected</p> <p>On write—ClearPortEnable: The HCD writes a logic 1 to this bit to clear bit PortEnableStatus. Writing a logic 0 has no effect. CurrentConnectStatus is not affected by any write.</p> <p>Remark: This bit always reads logic 1 when the attached device is nonremovable (DeviceRemoveable[NDP]).</p>

10.4 HC DMA and interrupt control registers

10.4.1 HcHardwareConfiguration register (R/W: 20H/A0H)

Code (Hex): 20 — read

Code (Hex): A0 — write

Table 36. HcHardwareConfiguration register: bit allocation

Bit	15	14	13	12	11	10	9	8
Symbol	reserved			2_DownstreamPort15Kresistorsel	SuspendClkNotStop	AnalogOCEnable	reserved	DACKMode
Reset	0	0	0	0	0	0	0	0
Access	R/W	R/W	R/W	R/W	R/W	R/W	R/W	R/W
Bit	7	6	5	4	3	2	1	0
Symbol	EOTInputPolarity	DACKInputPolarity	DREQOutputPolarity	DataBusWidth[1:0]		InterruptOutputPolarity	InterruptPinTrigger	InterruptPinEnable
Reset	0	0	1	0	1	0	0	0
Access	R/W	R/W	R/W	R/W	R/W	R/W	R/W	R/W

Table 37. HcHardwareConfiguration register: bit description

Bit	Symbol	Description
15 to 13	-	reserved
12	2_DownstreamPort15Kresistorsel	0 — use external 15 kΩ resistors for downstream ports 1 — use built-in resistors for downstream ports
11	SuspendClkNotStop	0 — clock can be stopped 1 — clock can not be stopped
10	AnalogOCEnable	0 — use external OC detection; digital input 1 — use on-chip OC detection; analog input
9	-	reserved
8	DACKMode	0 — normal operation; pin DACK_N is used with read and write signals 1 — reserved
7	EOTInputPolarity	0 — active LOW 1 — active HIGH
6	DACKInputPolarity	0 — active LOW 1 — reserved
5	DREQOutputPolarity	0 — active LOW 1 — active HIGH
4 to 3	DataBusWidth[1:0]	These bits are fixed at logic 0 and logic 1 for the ISP1160/01. 01 — 16 bits Others — reserved
2	InterruptOutputPolarity	0 — active LOW 1 — active HIGH
1	InterruptPinTrigger	0 — interrupt is level-triggered 1 — interrupt is edge-triggered
0	InterruptPinEnable	This bit is used as pin INT's master interrupt enable and should be used together with register HcUpInterruptEnable to enable pin INT. 0 — pin INT is disabled 1 — pin INT is enabled

10.4.2 HcDMAConfiguration register (R/W: 21H/A1H)

Code (Hex): 21 — read

Code (Hex): A1 — write

Table 38. HcDMAConfiguration register: bit allocation

Bit	15	14	13	12	11	10	9	8
Symbol	reserved							
Reset	0	0	0	0	0	0	0	0
Access	R/W	R/W	R/W	R/W	R/W	R/W	R/W	R/W
Bit	7	6	5	4	3	2	1	0
Symbol	reserved	BurstLen[1:0]		DMA Enable	reserved	DMA Counter Select	ITL_ATL_DataSelect	DMARead WriteSelect
Reset	0	0	0	0	0	0	0	0
Access	R/W	R/W	R/W	R/W	R/W	R/W	R/W	R/W

Table 39. HcDMAConfiguration register: bit description

Bit	Symbol	Description
15 to 7	-	reserved
6 to 5	BurstLen[1:0]	00 — single-cycle burst DMA 01 — 4-cycle burst DMA 10 — 8-cycle burst DMA 11 — reserved
4	DMAEnable	0 — DMA is terminated 1 — DMA is enabled This bit will be reset to logic 0 when DMA transfer is completed.
3	-	reserved
2	DMACounterSelect	0 — DMA counter not used. External EOT must be used 1 — enables the DMA counter for DMA transfer. HcTransferCounter register must be filled with non-zero values for DREQ to be raised after bit DMA Enable is set.
1	ITL_ATL_DataSelect	0 — ITL buffer RAM selected for ITL data 1 — ATL buffer RAM selected for ATL data
0	DMARead WriteSelect	0 — read from the HC FIFO buffer RAM 1 — write to the HC FIFO buffer RAM

10.4.3 HcTransferCounter register (R/W: 22H/A2H)

This register holds the number of bytes of a PIO or DMA transfer. For a PIO transfer, the number of bytes being read or written to the Isochronous Transfer List (ITL) or Acknowledged Transfer List (ATL) buffer RAM must be written into this register. For a DMA transfer, the number of bytes must be written into this register as well. However, for this counter to be read into the DMA counter, the HCD must set bit 2 (DMACounterSelect) of the HcDMAConfiguration register. The counter value for ATL must not be greater than 1000H, and for ITL it must not be greater than 800H. When the byte count of the data

transfer reaches this value, the HC will generate an internal EOT signal to set bit 2 (AIIEOTInterrupt) of the HcμPInterrupt register, and also update the HcBufferStatus register.

Code (Hex): 22 — read

Code (Hex): A2 — write

Table 40. HcTransferCounter register: bit allocation

Bit	15	14	13	12	11	10	9	8
Symbol	Counter value							
Reset	0	0	0	0	0	0	0	0
Access	R/W	R/W	R/W	R/W	R/W	R/W	R/W	R/W
Bit	7	6	5	4	3	2	1	0
Symbol	Counter value							
Reset	0	0	0	0	0	0	0	0
Access	R/W	R/W	R/W	R/W	R/W	R/W	R/W	R/W

Table 41. HcTransferCounter register: bit description

Bit	Symbol	Description
15 to 0	Counter value	The number of data bytes to be read to or written from RAM.

10.4.4 HcμPInterrupt register (R/W: 24H/A4H)

All the bits in this register will be active on power-on reset. However, none of the active bits will cause an interrupt on the interrupt pin (INT) unless they are set by the respective bits in the HcμPInterruptEnable register, and together with bit 0 of the HcHardwareConfiguration register.

After this register (24H to read) is read, the bits that are active will not be reset, until logic 1 is written to the bits in this register (A4H to write) to clear it. To clear all the enabled bits in this register, the HCD must write FFH to this register.

Code (Hex): 24 — read

Code (Hex): A4 — write

Table 42. HcμPInterrupt register: bit allocation

Bit	15	14	13	12	11	10	9	8
Symbol	reserved							
Reset	0	0	0	0	0	0	0	0
Access	R/W	R/W	R/W	R/W	R/W	R/W	R/W	R/W
Bit	7	6	5	4	3	2	1	0
Symbol	reserved	ClkReady	HC Suspended	OPR_Reg	reserved	AIIEOT Interrupt	ATLInt	SOFITLInt
Reset	0	0	0	0	0	0	0	0
Access	R/W	R/W	R/W	R/W	R/W	R/W	R/W	R/W

Table 43. HcμPInterrupt register: bit description

Bit	Symbol	Description
15 to 7	-	reserved
6	ClkReady	0 — no event 1 — clock is ready. After a wake-up is sent, there is a wait for clock ready. Maximum is 1 ms, and typical is 160 μs.
5	HC Suspended	0 — no event 1 — the HC has been suspended and no USB activity is sent from the microprocessor for each ms. When the microprocessor wants to suspend the HC, the microprocessor must write to the HcControl register. And when all downstream devices are suspended, then the HC stops sending SOF; the HC is suspended by having the HcControl register written into.
4	OPR_Reg	0 — no event 1 — there are interrupts from HC side. Need to read HcControl and HcInterrupt registers to detect type of interrupt on the HC (if the HC requires the operational register to be updated).
3	-	reserved
2	AllEOT Interrupt	0 — no event 1 — implies that data transfer has been completed via PIO transfer or DMA transfer. Occurrence of internal or external EOT will set this bit.
1	ATLInt	0 — no event 1 — implies that the microprocessor must read ATL data from the HC. This requires that the HcBufferStatus register must first be read. The time for this interrupt depends on the number of clocks bit set for USB activities in each ms.
0	SOFITLInt	0 — no event 1 — implies that SOF indicates the 1 ms mark. The ITL buffer that the HC has handled must be read. To know the ITL buffer status, the HcBufferStatus register must first be read. This is for the microprocessor to get ISO data to or from the HC. For more information, see the 6th paragraph in Section 9.5 .

10.4.5 HcμPInterruptEnable register (R/W: 25H/A5H)

The bits 6:0 in this register are the same as those in the HcμPInterrupt register. They are used together with bit 0 of the HcHardwareConfiguration register to enable or disable the bits in the HcμPInterrupt register.

On power-on, all bits in this register are masked with logic 0. This means no interrupt request output on the interrupt pin INT can be generated.

When the bit is set to logic 1, the interrupt for the bit is not masked but enabled.

Code (Hex): 25 — read

Code (Hex): A5 — write

Table 44. Hc μ PInterruptEnable register: bit allocation

Bit	15	14	13	12	11	10	9	8
Symbol	reserved							
Reset	0	0	0	0	0	0	0	0
Access	R/W	R/W	R/W	R/W	R/W	R/W	R/W	R/W
Bit	7	6	5	4	3	2	1	0
Symbol	reserved	ClkReady	HC Suspended Enable	OPR Interrupt Enable	reserved	EOT Interrupt Enable	ATL Interrupt Enable	SOF Interrupt Enable
Reset	0	0	0	0	0	0	0	0
Access	R/W	R/W	R/W	R/W	R/W	R/W	R/W	R/W

Table 45. Hc μ PInterruptEnable register: bit description

Bit	Symbol	Description
15 to 7	-	reserved
6	ClkReady	0 — power-up value 1 — enables ClkReady interrupt
5	HC Suspended Enable	0 — power-up value 1 — enables HC suspended interrupt. When the microprocessor wants to suspend the HC, the microprocessor must write to the HcControl register. And when all downstream devices are suspended, then the HC stops sending SOF; the HC is suspended by having the HcControl register written into.
4	OPR Interrupt Enable	0 — power-up value 1 — enables the 32-bit operational register's interrupt (if the HC requires the operational register to be updated)
3	-	reserved
2	EOT Interrupt Enable	0 — power-up value 1 — enables the EOT interrupt which indicates an end of a read/write transfer
1	ATL Interrupt Enable	0 — power-up value 1 — enables ATL interrupt. The time for this interrupt depends on the number of clock bits set for USB activities in each ms.
0	SOF Interrupt Enable	0 — power-up value 1 — enables the interrupt bit due to SOF (for the microprocessor DMA to get ISO data from the HC by first accessing the HcDMAConfiguration register)

10.5 HC miscellaneous registers

10.5.1 HcChipID register (R: 27H)

Read this register to get the ID of the ISP1160/01 silicon chip. The higher byte stands for the product name. The lower byte indicates the revision number of the product including engineering samples.

Code (Hex): 27 — read

Table 46. HcChipID register: bit allocation

Bit	15	14	13	12	11	10	9	8
Symbol	ChipID[15:8]							
Reset	0	1	1	0	0	0	0	1
Access	R	R	R	R	R	R	R	R
Bit	7	6	5	4	3	2	1	0
Symbol	ChipID[7:0]							
Reset	0	0	1	0	0	0	1	1
Access	R	R	R	R	R	R	R	R

Table 47. HcChipID register: bit description

Bit	Symbol	Description
15 to 0	ChipID[15:0]	ISP1160/01's chip ID

10.5.2 HcScratch register (R/W: 28H/A8H)

This register is for the HCD to save and restore values when required.

Code (Hex): 28 — read

Code (Hex): A8 — write

Table 48. HcScratch register: bit allocation

Bit	15	14	13	12	11	10	9	8
Symbol	Scratch[15:8]							
Reset	0	0	0	0	0	0	0	0
Access	R/W	R/W	R/W	R/W	R/W	R/W	R/W	R/W
Bit	7	6	5	4	3	2	1	0
Symbol	Scratch[7:0]							
Reset	0	0	0	0	0	0	0	0
Access	R/W	R/W	R/W	R/W	R/W	R/W	R/W	R/W

Table 49. HcScratch register: bit description

Bit	Symbol	Description
15 to 0	Scratch[15:0]	Scratch register value

10.5.3 HcSoftwareReset register (W: A9H)

This register provides a means for software reset of the HC. To reset the HC, the HCD must write a reset value of F6H to this register. Upon receiving the reset value, the HC resets all the registers except its buffer memory.

Code (Hex): A9 — write

Table 50. HcSoftwareReset register: bit allocation

Bit	15	14	13	12	11	10	9	8
Symbol	Reset[15:8]							
Reset	0	0	0	0	0	0	0	0
Access	W	W	W	W	W	W	W	W

Bit	7	6	5	4	3	2	1	0
Symbol	Reset[7:0]							
Reset	0	0	0	0	0	0	0	0
Access	W	W	W	W	W	W	W	W

Table 51. HcSoftwareReset register: bit description

Bit	Symbol	Description
15 to 0	Reset[15:0]	Writing a reset value of F6H will cause the HC to reset all the registers except its buffer memory.

10.6 HC buffer RAM control registers

10.6.1 HcITLBufferLength register (R/W: 2AH/AAH)

Write to this register to assign the ITL buffer size in bytes: ITL0 and ITL1 are assigned the same value. For example, if HcITLBufferLength register is set to 2 kbytes, then ITL0 and ITL1 would be allocated 2 kbytes each.

Must follow the formula:

$$\text{ATL buffer length} + 2 \times (\text{ITL buffer size}) \leq 1000\text{H} \text{ (that is, 4 kbytes)}$$

where: ITL buffer size = ITL0 buffer length = ITL1 buffer length.

Code (Hex): 2A — read

Code (Hex): AA — write

Table 52. HcITLBufferLength register: bit allocation

Bit	15	14	13	12	11	10	9	8
Symbol	ITLBufferLength[15:8]							
Reset	0	0	0	0	0	0	0	0
Access	R/W	R/W	R/W	R/W	R/W	R/W	R/W	R/W
Bit	7	6	5	4	3	2	1	0
Symbol	ITLBufferLength[7:0]							
Reset	0	0	0	0	0	0	0	0
Access	R/W	R/W	R/W	R/W	R/W	R/W	R/W	R/W

Table 53. HcITLBufferLength register: bit description

Bit	Symbol	Description
15 to 0	ITLBufferLength[15:0]	Assign ITL buffer length

10.6.2 HcATLBufferLength register (R/W: 2BH/ABH)

Write to this register to assign ATL buffer size.

Code (Hex): 2B — read

Code (Hex): AB — write

Remark: The maximum total RAM size is 1000H (4096 in decimal) bytes. That means $ITL0 \text{ (length)} + ITL1 \text{ (length)} + ATL \text{ (length)} \leq 1000H$ bytes. For example, if ATL buffer length has been set to be 800H, then the maximum ITL buffer length can only be set as 400H.

Table 54. HcATLBufferLength register: bit allocation

Bit	15	14	13	12	11	10	9	8
Symbol	ATLBufferLength[15:8]							
Reset	0	0	0	0	0	0	0	0
Access	R/W	R/W	R/W	R/W	R/W	R/W	R/W	R/W
Bit	7	6	5	4	3	2	1	0
Symbol	ATLBufferLength[7:0]							
Reset	0	0	0	0	0	0	0	0
Access	R/W	R/W	R/W	R/W	R/W	R/W	R/W	R/W

Table 55. HcATLBufferLength register: bit description

Bit	Symbol	Description
15 to 0	ATLBufferLength[15:0]	Assign ATL buffer length

10.6.3 HcBufferStatus register (R: 2CH)

Code (Hex): 2C — read

Table 56. HcBufferStatus register: bit allocation

Bit	15	14	13	12	11	10	9	8
Symbol	reserved							
Reset	0	0	0	0	0	0	0	0
Access	R	R	R	R	R	R	R	R
Bit	7	6	5	4	3	2	1	0
Symbol	reserved		ATLBuffer Done	ITL1Buffer Done	ITL0Buffer Done	ATLBuffer Full	ITL1Buffer Full	ITL0Buffer Full
Reset	0	0	0	0	0	0	0	0
Access	R	R	R	R	R	R	R	R

Table 57. HcBufferStatus register: bit description

Bit	Symbol	Description
15 to 6	-	reserved
5	ATLBuffer Done	0 — ATL Buffer not read by HC yet 1 — ATL Buffer read by HC
4	ITL1BufferDone	0 — ITL1 Buffer not read by HC yet 1 — ITL1 Buffer read by HC

Table 57. HcBufferStatus register: bit description ...continued

Bit	Symbol	Description
3	ITL0BufferDone	0 — ITL0 Buffer not read by HC yet 1 — ITL0 Buffer read by HC
2	ATLBufferFull	0 — ATL Buffer is empty 1 — ATL Buffer is full
1	ITL1BufferFull	0 — ITL1 Buffer is empty 1 — ITL1 Buffer is full
0	ITL0BufferFull	0 — ITL0 Buffer is empty 1 — ITL0 Buffer is full

10.6.4 HcReadBackITL0Length register (R: 2DH)

This register's value stands for the current number of data bytes inside an ITL0 buffer to be read back by the microprocessor. The HCD must set the HcTransferCounter equivalent to this value before reading back the ITL0 buffer RAM.

Code (Hex): 2D — read

Table 58. HcReadBackITL0Length register: bit allocation

Bit	15	14	13	12	11	10	9	8
Symbol	RdITL0BufferLength[15:8]							
Reset	0	0	0	0	0	0	0	0
Access	R	R	R	R	R	R	R	R
Bit	7	6	5	4	3	2	1	0
Symbol	RdITL0BufferLength[7:0]							
Reset	0	0	0	0	0	0	0	0
Access	R	R	R	R	R	R	R	R

Table 59. HcReadBackITL0Length register: bit description

Bit	Symbol	Description
15 to 0	RdITL0BufferLength[15:0]	The number of bytes for ITL0 data to be read back by the microprocessor

10.6.5 HcReadBackITL1Length register (R: 2EH)

This register's value stands for the current number of data bytes inside the ITL1 buffer to be read back by the microprocessor. The HCD must set the HcTransferCounter equivalent to this value before reading back the ITL1 buffer RAM.

Code (Hex): 2E — read

Table 60. HcReadBackITL1Length register: bit allocation

Bit	15	14	13	12	11	10	9	8
Symbol	RdITL1BufferLength[15:8]							
Reset	0	0	0	0	0	0	0	0
Access	R	R	R	R	R	R	R	R

Bit	7	6	5	4	3	2	1	0
Symbol	RdITL1BufferLength[7:0]							
Reset	0	0	0	0	0	0	0	0
Access	R	R	R	R	R	R	R	R

Table 61. HcReadBackITL1Length register: bit description

Bit	Symbol	Description
15 to 0	RdITL1BufferLength[15:0]	The number of bytes for ITL1 data to be read back by the microprocessor.

10.6.6 HcITLBufferPort register (R/W: 40H/C0H)

This is the ITL buffer RAM read/write port. The bits 15:8 contain the data byte that comes from the ITL buffer RAM's even address. The bits 7:0 contain the data byte that comes from the ITL buffer RAM's odd address.

Code (Hex): 40 — read

Code (Hex): C0 — write

Table 62. HcITLBufferPort register: bit allocation

Bit	15	14	13	12	11	10	9	8
Symbol	DataWord[15:8]							
Reset	0	0	0	0	0	0	0	0
Access	R/W	R/W	R/W	R/W	R/W	R/W	R/W	R/W
Bit	7	6	5	4	3	2	1	0
Symbol	DataWord[7:0]							
Reset	0	0	0	0	0	0	0	0
Access	R/W	R/W	R/W	R/W	R/W	R/W	R/W	R/W

Table 63. HcITLBufferPort register: bit description

Bit	Symbol	Description
15 to 0	DataWord[15:0]	Read/write ITL buffer RAM's two data bytes.

The HCD must set the byte count into the HcTransferCounter register and check the HcBufferStatus register before reading from or writing to the buffer. The HCD must write the command (40H to read, C0H to write) once only, and then read or write both bytes of the data word. After every read/write, the pointer of ITL buffer RAM will be automatically increased by two to point to the next data word until it reaches the value of the HcTransferCounter register; otherwise, an internal EOT signal is not generated to set bit 2 (AllEOTInterrupt) of the HcμPInterrupt register and update the HcBufferStatus register.

The HCD must take care of the fact that the internal buffer RAM is organized in bytes. The HCD must write the byte count into the HcTransferCounter register, but the HCD reads or writes the buffer RAM by 16 bits (by 1 word).

10.6.7 HcATLBufferPort register (R/W: 41H/C1H)

This is the ATL buffer RAM read/write port. Bits 15 to 8 contain the data byte that comes from the Acknowledged Transfer List (ATL) buffer RAM's odd address. Bits 7 to 0 contain the data byte that comes from the ATL buffer RAM's even address.

Code (Hex): 41 — read

Code (Hex): C1 — write

Table 64. HcATLBufferPort register: bit allocation

Bit	15	14	13	12	11	10	9	8
Symbol	DataWord[15:8]							
Reset	0	0	0	0	0	0	0	0
Access	R/W	R/W	R/W	R/W	R/W	R/W	R/W	R/W
Bit	7	6	5	4	3	2	1	0
Symbol	DataWord[7:0]							
Reset	0	0	0	0	0	0	0	0
Access	R/W	R/W	R/W	R/W	R/W	R/W	R/W	R/W

Table 65. HcATLBufferPort register: bit description

Bit	Symbol	Description
15 to 0	DataWord[15:0]	Read/write ATL buffer RAM's two data bytes.

The HCD must set the byte count into the HcTransferCounter register and check the HcBufferStatus register before reading from or writing to the buffer. The HCD must write the command (41H to read, C1H to write) once only, and then read or write both bytes of the data word. After every read/write, the pointer of ATL buffer RAM will be automatically increased by two to point to the next data word until it reaches the value of the HcTransferCounter register; otherwise, an internal EOT signal is not generated to set bit 2 (AllEOTInterrupt) of the HcμPInterrupt register and update the HcBufferStatus register.

The HCD must take care of the difference: the internal buffer RAM is organized in bytes, so the HCD must write the byte count into the HcTransferCounter register, but the HCD reads or writes the buffer RAM by 16 bits (by 1 data word).

11. Power supply

The ISP1160/01 can operate at either 5 V or 3.3 V.

When using 5 V as the ISP1160/01’s power supply input, only V_{CC} (pin 56) can be connected to the 5 V power supply. An application with a 5 V power supply input is shown in [Figure 29](#). The ISP1160/01 has an internal DC/DC regulator to provide 3.3 V for its internal core. This internal 3.3 V can also be obtained from $V_{REG(3V3)}$ (pin 58).

When using 3.3 V as the power supply input, the internal DC/DC regulator will be bypassed. All four power supply pins (V_{CC} , $V_{REG(3V3)}$, V_{HOLD1} and V_{HOLD2}) can be used as power supply input.

It is recommended that you connect all four power supply pins to the 3.3 V power supply, as shown in [Figure 30](#). If, however, you have board space (routing area) constraints, you must connect at least V_{CC} and $V_{REG(3V3)}$ to the 3.3 V power supply.

For both 3.3 V and 5 V operation, all four power supply pins should be connected to a decoupling capacitor.

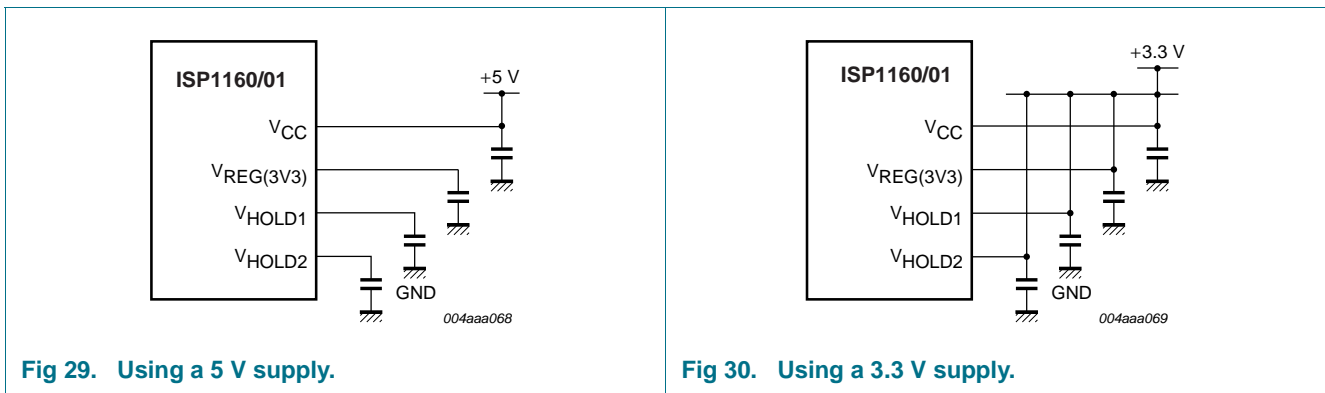

Fig 29. Using a 5 V supply.

Fig 30. Using a 3.3 V supply.

12. Crystal oscillator

The ISP1160/01 has a crystal oscillator designed for a 6 MHz parallel-resonant crystal (fundamental). A typical circuit is shown in [Figure 31](#). Alternatively, an external clock signal of 6 MHz can be applied to input XTAL1, while leaving output XTAL2 open. See [Figure 32](#). The 6 MHz oscillator frequency is multiplied to 48 MHz by an internal PLL.

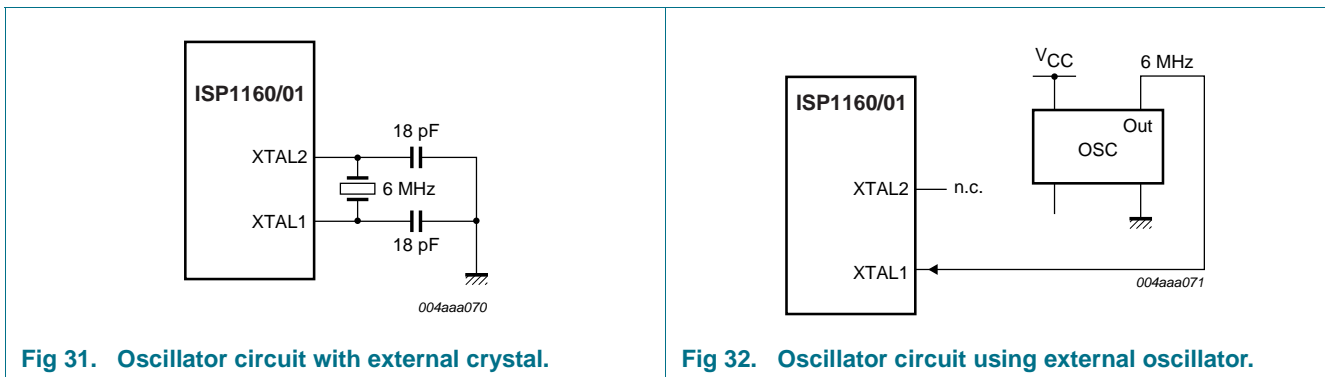

Fig 31. Oscillator circuit with external crystal.

Fig 32. Oscillator circuit using external oscillator.

13. Power-on reset (POR)

When V_{CC} is directly connected to the RESET_N pin, the internal pulse width (t_{PORP}) will be typically (600 ns to 1000 ns) + X, when V_{CC} is 3.3 V. The time X depends on how fast V_{CC} is rising with respect to V_{trip} (2.03 V). The time X is decided by the external power supply circuit.

To give a better view of the functionality, [Figure 33](#) shows a possible curve of $V_{CC(POR)}$ with dips at t2-t3 and t4-t5. If the dip at t4-t5 is too short (that is, < 11 μ s), the internal POR pulse will not react and will remain LOW. The internal POR starts with a 1 at t0. At t1, the detector will see the passing of the trip level and a delay element will add another t_{PORP} before it drops to 0.

The internal POR pulse will be generated whenever $V_{CC(POR)}$ drops below V_{trip} for more than 11 μ s.

Even if V_{CC} is 5.0 V, V_{trip} still remains at 2.03 V. This is because the 5 V tolerant pads and on-chip voltage regulator ensure that 3.3 V is going to the internal POR circuitry by clipping the voltage above 3.3 V.

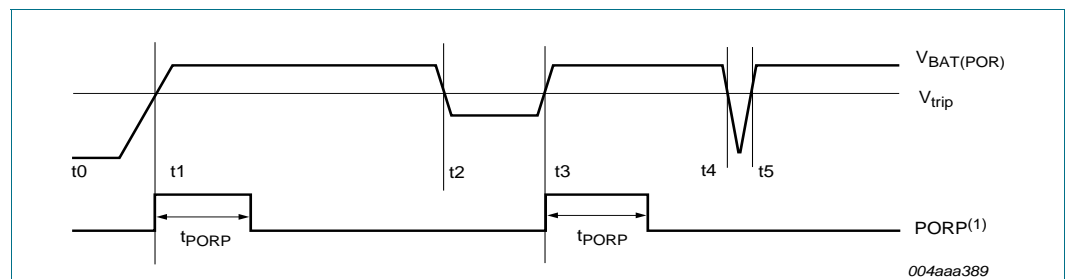

(1) PORP = power-on reset pulse.

Fig 33. Internal POR timing.

The RESET_N pin can be either connected to V_{CC} (using the internal POR circuit) or externally controlled (by the microprocessor, ASIC, and so on). [Figure 34](#) shows the availability of the clock with respect to the external POR.

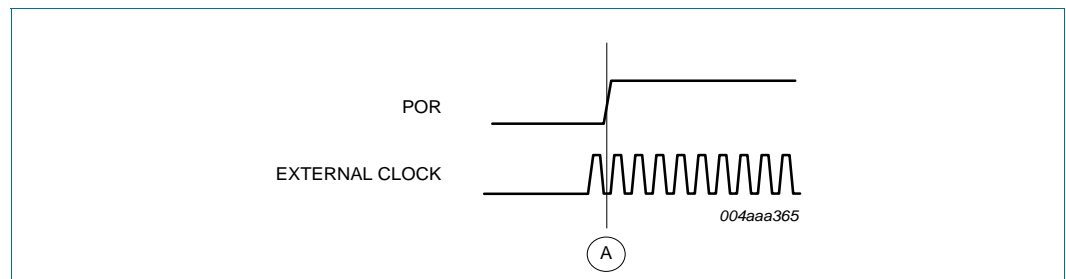

Stable external clock is available at A.

Fig 34. Clock with respect to the external POR.

14. Limiting values

Table 66. Absolute maximum ratings

In accordance with the Absolute Maximum Rating System (IEC 60134).

Symbol	Parameter	Conditions	Min	Max	Unit
$V_{CC(5V0)}$	supply voltage to pin V_{CC}		-0.5	+6.0	V
$V_{CC(3V3)}$	supply voltage to pin $V_{REG(3V3)}$		-0.5	+4.6	V
V_I	input voltage		-0.5	+6.0	V
I_{lu}	latch-up current	$V_I < 0$ or $V_I > V_{CC}$	-	100	mA
V_{esd}	electrostatic discharge voltage	$I_{LI} < 1 \mu A$	[1] -2000	+2000	V
T_{stg}	storage temperature		-60	+150	°C

[1] Equivalent to discharging a 100 pF capacitor via a 1.5 k Ω resistor (Human Body Model).

15. Recommended operating conditions

Table 67. Recommended operating conditions

Symbol	Parameter	Conditions	Min	Typ	Max	Unit
V_{CC}	supply voltage	with internal regulator	4.0	5.0	5.5	V
		internal regulator bypass	3.0	3.3	3.6	V
V_I	input voltage		[1] 0	V_{CC}	5.5	V
$V_{I(AI/O)}$	input voltage on analog I/O pins D+ and D-		0	-	3.6	V
$V_{O(od)}$	open-drain output pull-up voltage		0	-	V_{CC}	V
T_{amb}	ambient temperature		-40	-	+85	°C

[1] Maximum value is 5 V tolerant.

16. Static characteristics

Table 68. Static characteristics; supply pins

$V_{CC} = 3.0\text{ V to }3.6\text{ V or }4.0\text{ V to }5.5\text{ V}$; $V_{GND} = 0\text{ V}$; $T_{amb} = -40\text{ °C to }+85\text{ °C}$; typical values at $T_{amb} = 25\text{ °C}$; unless otherwise specified.

Symbol	Parameter	Conditions	Min	Typ	Max	Unit
$V_{CC} = 5\text{ V}$						
$V_{REG(3V3)}$	internal regulator output		[1] 3.0	3.3	3.6	V
I_{CC}	operating supply current		-	47	-	mA
$I_{CC(susp)}$	suspend supply current		-	40	500	μA
$V_{CC} = 3.3\text{ V}$						
I_{CC}	operating supply current		-	50	-	mA
$I_{CC(susp)}$	suspend supply current		[2] -	150	500	μA

[1] In the suspend mode, the minimum voltage is 2.7 V.

[2] For details on power consumption, refer to ST-NXP Wireless Application Note AN10022 *ISP1160x Low Power Consumption*.

Table 69. Static characteristics: digital pins

$V_{CC} = 3.0\text{ V to }3.6\text{ V or }4.0\text{ V to }5.5\text{ V}$; $V_{GND} = 0\text{ V}$; $T_{amb} = -40\text{ °C to }+85\text{ °C}$; unless otherwise specified.

Symbol	Parameter	Conditions	Min	Typ	Max	Unit
Input levels						
V_{IL}	LOW-level input voltage		-	-	0.8	V
V_{IH}	HIGH-level input voltage		2.0	-	-	V
Schmitt trigger inputs						
$V_{th(LH)}$	positive-going threshold voltage		1.4	-	1.9	V
$V_{th(HL)}$	negative-going threshold voltage		0.9	-	1.5	V
V_{hys}	hysteresis voltage		0.4	-	0.7	V
Output levels						
V_{OL}	LOW-level output voltage	$I_{OL} = 4\text{ mA}$	-	-	0.4	V
		$I_{OL} = 20\text{ }\mu\text{A}$	-	-	0.1	V
V_{OH}	HIGH-level output voltage	$I_{OH} = 4\text{ mA}$	[1] 2.4	-	-	V
		$I_{OH} = 20\text{ }\mu\text{A}$	$V_{REG(3V3)} - 0.1$	-	-	V
Leakage current						
I_{LI}	input leakage current		[2] -5	-	+5	μA
C_{IN}	pin capacitance	pin to GND	-	-	5	pF
Open-drain outputs						
I_{OZ}	OFF-state output current		-5	-	+5	μA

[1] Not applicable for open-drain outputs.

[2] The maximum and minimum values are applicable to transistor input only. The value will be different if internal pull-up or pull-down resistors are used.

Table 70. Static characteristics: analog I/O pins D+ and D–

$V_{CC} = 3.0\text{ V to }3.6\text{ V or }4.0\text{ V to }5.5\text{ V}$; $V_{GND} = 0\text{ V}$; $T_{amb} = -40\text{ }^{\circ}\text{C to }+85\text{ }^{\circ}\text{C}$; unless otherwise specified.

Symbol	Parameter	Conditions	Min	Typ	Max	Unit
Input levels						
V_{DI}	differential input sensitivity	$ V_{I(D+)} - V_{I(D-)} $	[1] 0.2	-	-	V
V_{CM}	differential common mode voltage	includes V_{DI} range	0.8	-	2.5	V
V_{IL}	LOW-level input voltage		-	-	0.8	V
V_{IH}	HIGH-level input voltage		2.0	-	-	V
Output levels						
V_{OL}	LOW-level output voltage	$R_L = 1.5\text{ k}\Omega$ to + 3.6 V	-	-	0.3	V
V_{OH}	HIGH-level output voltage	$R_L = 15\text{ k}\Omega$ to GND	2.8	-	3.6	V
Leakage current						
I_{LZ}	OFF-state leakage current		-10	-	+10	μA
Capacitance						
C_{IN}	transceiver capacitance	pin to GND	-	-	10	pF
Resistance						
R_{PD}	pull-down resistance on HC's D+/D–	enable internal resistors	10	-	20	k Ω
Z_{DRV}	driver output impedance	steady-state drive	[2] 29	-	44	Ω
Z_{INP}	input impedance		10	-	-	M Ω

[1] D+ is the USB positive data pin; D– is the USB negative data pin.

[2] Includes external resistors of $18\text{ }\Omega \pm 1\%$ on both pins H_D+ and H_D–.

17. Dynamic characteristics

Table 71. Dynamic characteristics

$V_{CC} = 3.0\text{ V to }3.6\text{ V or }4.0\text{ V to }5.5\text{ V}$; $V_{GND} = 0\text{ V}$; $T_{amb} = -40\text{ }^{\circ}\text{C to }+85\text{ }^{\circ}\text{C}$; unless otherwise specified.

Symbol	Parameter	Conditions	Min	Typ	Max	Unit
Reset						
$t_{W(\text{RESET_N})}$	pulse width on input RESET_N	crystal oscillator running	160	-	-	μs
		crystal oscillator stopped	[1]	-	-	ms
Crystal oscillator						
f_{XTAL}	crystal frequency		-	6	-	MHz
R_S	series resistance		-	-	100	Ω
C_{LOAD}	load capacitance	$C_{x1}, C_{x2} = 22\text{ pF}$	-	18	-	pF
External clock input						
t_J	external clock jitter		-	-	500	ps
t_{DUTY}	clock duty cycle		45	50	55	%
$t_{\text{CR}}, t_{\text{CF}}$	rise time and fall time		-	-	3	ns

[1] Dependent on the crystal oscillator start-up time.

Table 72. Dynamic characteristics: analog I/O pins D+ and D-

$V_{CC} = 3.0\text{ V to }3.6\text{ V or }4.0\text{ V to }5.5\text{ V}$; $V_{GND} = 0\text{ V}$; $T_{amb} = -40\text{ }^{\circ}\text{C to }+85\text{ }^{\circ}\text{C}$; $C_L = 50\text{ pF}$; see [Figure 42](#) for test circuit; unless otherwise specified.

Symbol	Parameter	Conditions	Min	Typ	Max	Unit
Driver characteristics						
t_{FR}	rise time	$C_L = 50\text{ pF}$; 10 % to 90 % of $ V_{\text{OH}} - V_{\text{OL}} $	4	-	20	ns
t_{FF}	fall time	$C_L = 50\text{ pF}$; 90 % to 10 % of $ V_{\text{OH}} - V_{\text{OL}} $	4	-	20	ns
FRFM	differential rise/fall time matching ($t_{\text{FR}}/t_{\text{FF}}$)		[1]	90	-	111.11 %
V_{CRS}	output signal crossover voltage		[1][2]	1.3	-	2.0 V

[1] Excluding the first transition from Idle state.

[2] Characterized only, not tested. Limits guaranteed by design.

17.1 Programmed I/O timing

Table 73. Dynamic characteristics: programmed interface timing

Symbol	Parameter	Conditions	Min	Typ	Max	Unit
t_{AS}	address set-up time before WR_N HIGH		5	-	-	ns
t_{AH}	address hold time after WR_N HIGH		8	-	-	ns
Read timing						
t_{SHSL}	first RD_N/WR_N after A0 HIGH		300	-	-	ns
t_{SLRL}	CS_N LOW to RD_N LOW		0	-	-	ns
t_{RHSH}	RD_N HIGH to CS_N HIGH		0	-	-	ns
t_{RLRH}	RD_N LOW pulse width		33	-	-	ns
t_{RHRL}	RD_N HIGH to next RD_N LOW		110	-	-	ns
T_{RC}	RD_N cycle		143	-	-	ns
t_{RHDZ}	RD_N data hold time		3	-	22	ns
t_{RLDV}	RD_N LOW to data valid		-	-	32	ns
Write timing						
t_{WL}	WR_N LOW pulse width		26	-	-	ns
t_{WHWL}	WR_N HIGH to next WR_N LOW		110	-	-	ns
T_{WC}	WR_N cycle		136	-	-	ns
t_{SLWL}	CS_N LOW to WR_N LOW		0	-	-	ns
t_{WHS}	WR_N HIGH to CS_N HIGH		0	-	-	ns
t_{WDSU}	WR_N data set-up time		5	-	-	ns
t_{WDH}	WR_N data hold time		8	-	-	ns

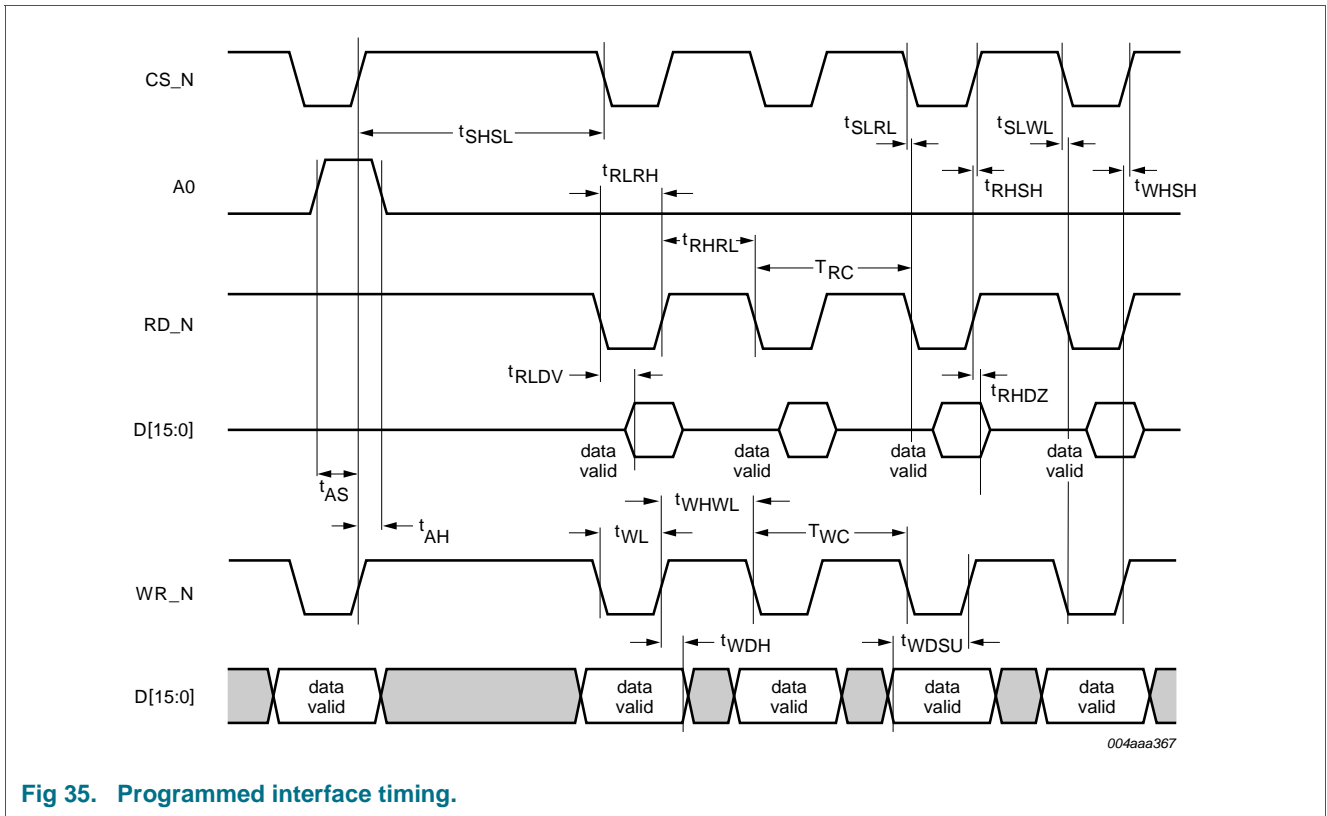

Fig 35. Programmed interface timing.

17.2 DMA timing

17.2.1 Single-cycle DMA timing

Table 74. Dynamic characteristics: single-cycle DMA timing

Symbol	Parameter	Conditions	Min	Typ	Max	Unit
Read/write timing						
t _{RLRH}	RD_N pulse width		33	-	-	ns
t _{RLDV}	read process data set-up time		26	-	-	ns
t _{RHDZ}	read process data hold time		0	-	20	ns
t _{WSU}	write process data set-up time		5	-	-	ns
t _{WHD}	write process data hold time		0	-	-	ns
t _{AHRH}	DACK_N HIGH to DREQ HIGH		72	-	-	ns
t _{ALRL}	DACK_N LOW to DREQ LOW		-	-	21	ns
T _{DC}	DREQ cycle		[1]	-	-	ns
t _{SHAH}	RD_N/WR_N HIGH to DACK_N HIGH		0	-	-	ns
t _{RHAL}	DREQ HIGH to DACK_N LOW		0	-	-	ns
t _{DS}	DREQ pulse spacing		146	-	-	ns

[1] T_{DC} = t_{RHAL} + t_{DS} + t_{ALRL}

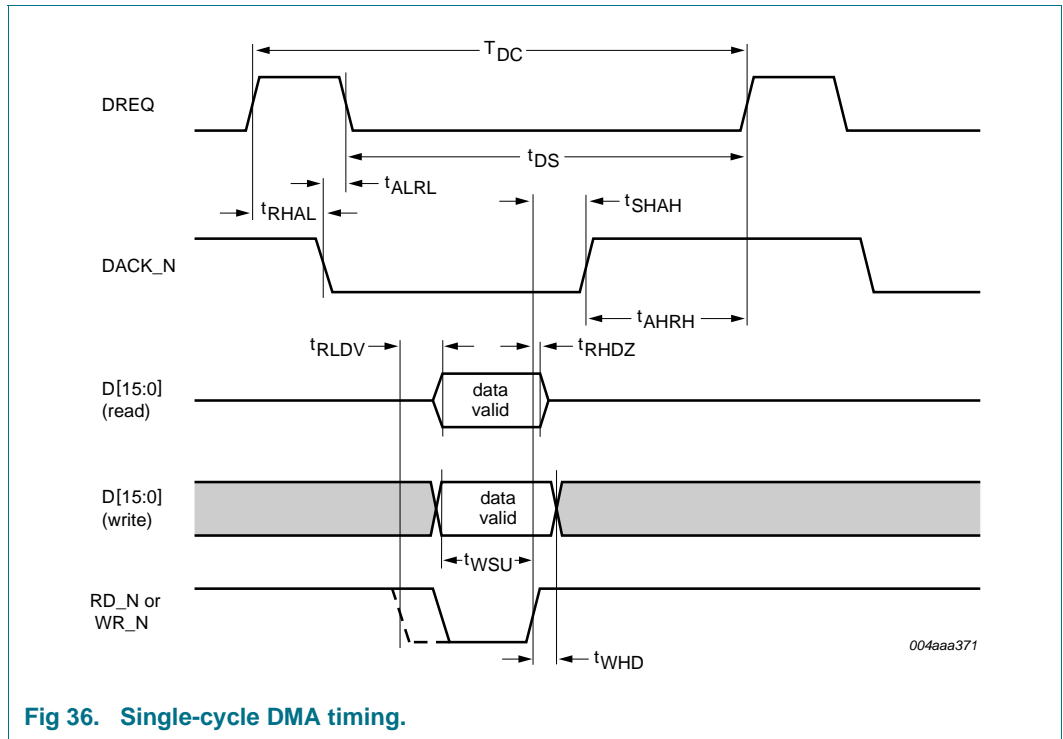

Fig 36. Single-cycle DMA timing.

17.2.2 Burst mode DMA timing

Table 75. Dynamic characteristics: burst mode DMA timing

Symbol	Parameter	Conditions	Min	Typ	Max	Unit
Read/write timing (for 4-cycle and 8-cycle burst mode)						
t_{RLRH}	WR_N/RD_N LOW pulse width		42	-	-	ns
t_{RHRL}	WR_N/RD_N HIGH to next WR_N/RD_N LOW		60	-	-	ns
T_{RC}	WR_N/RD_N cycle		102	-	-	ns
t_{SLRL}	RD_N/WR_N LOW to DREQ LOW		22	-	64	ns
t_{SHAH}	RD_N/WR_N HIGH to DACK_N HIGH		0	-	-	ns
t_{SLAL}	DREQ HIGH to DACK_N LOW		0	-	-	ns
T_{DC}	DREQ cycle		[1]	-	-	ns
$t_{DS(read)}$	DREQ pulse spacing (read)	4-cycle burst mode	105	-	-	ns
$t_{DS(read)}$	DREQ pulse spacing (read)	8-cycle burst mode	150	-	-	ns
$t_{DS(write)}$	DREQ pulse spacing (write)	4-cycle burst mode	72	-	-	ns
$t_{DS(write)}$	DREQ pulse spacing (write)	8-cycle burst mode	167	-	-	ns
t_{RLIS}	RD_N/WR_N LOW to EOT LOW		0	-	-	ns

[1] $T_{DC} = t_{SLAL} + (4 \text{ or } 8)T_{RC} + t_{DS}$

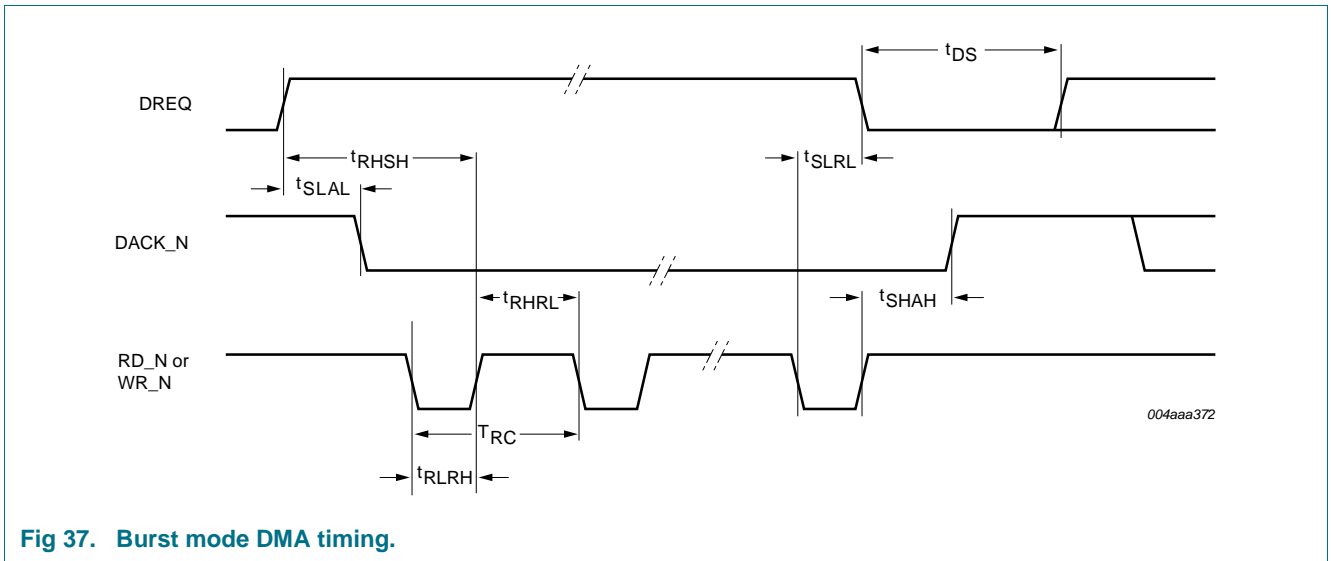

Fig 37. Burst mode DMA timing.

17.2.3 External EOT timing for single-cycle DMASETUP

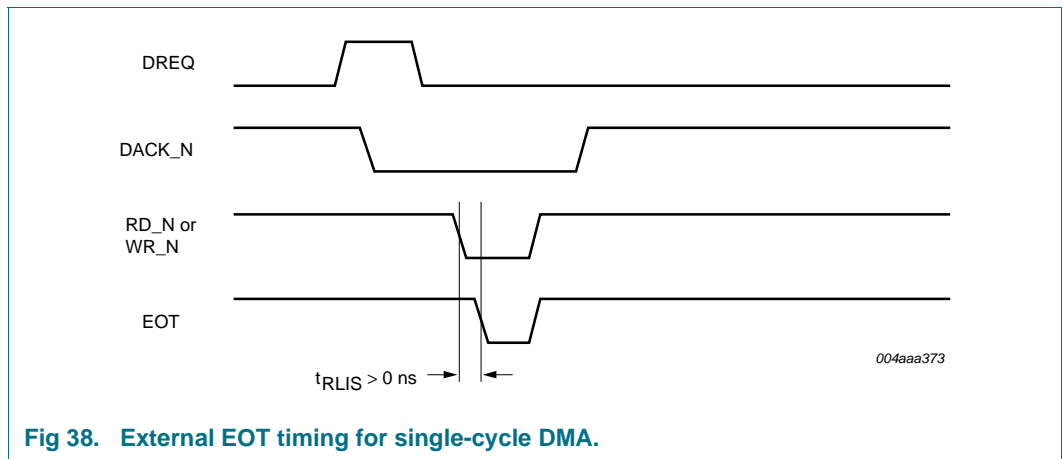

Fig 38. External EOT timing for single-cycle DMA.

17.2.4 External EOT timing for burst mode DMA

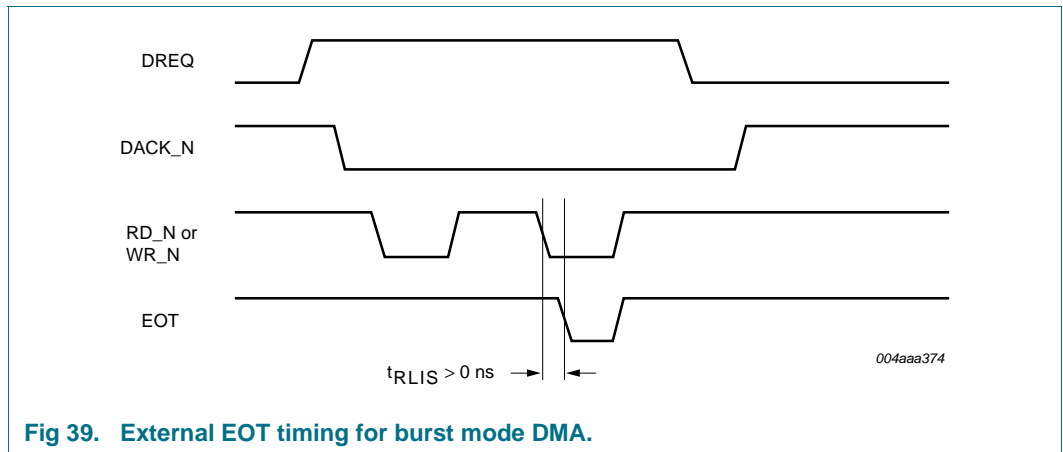
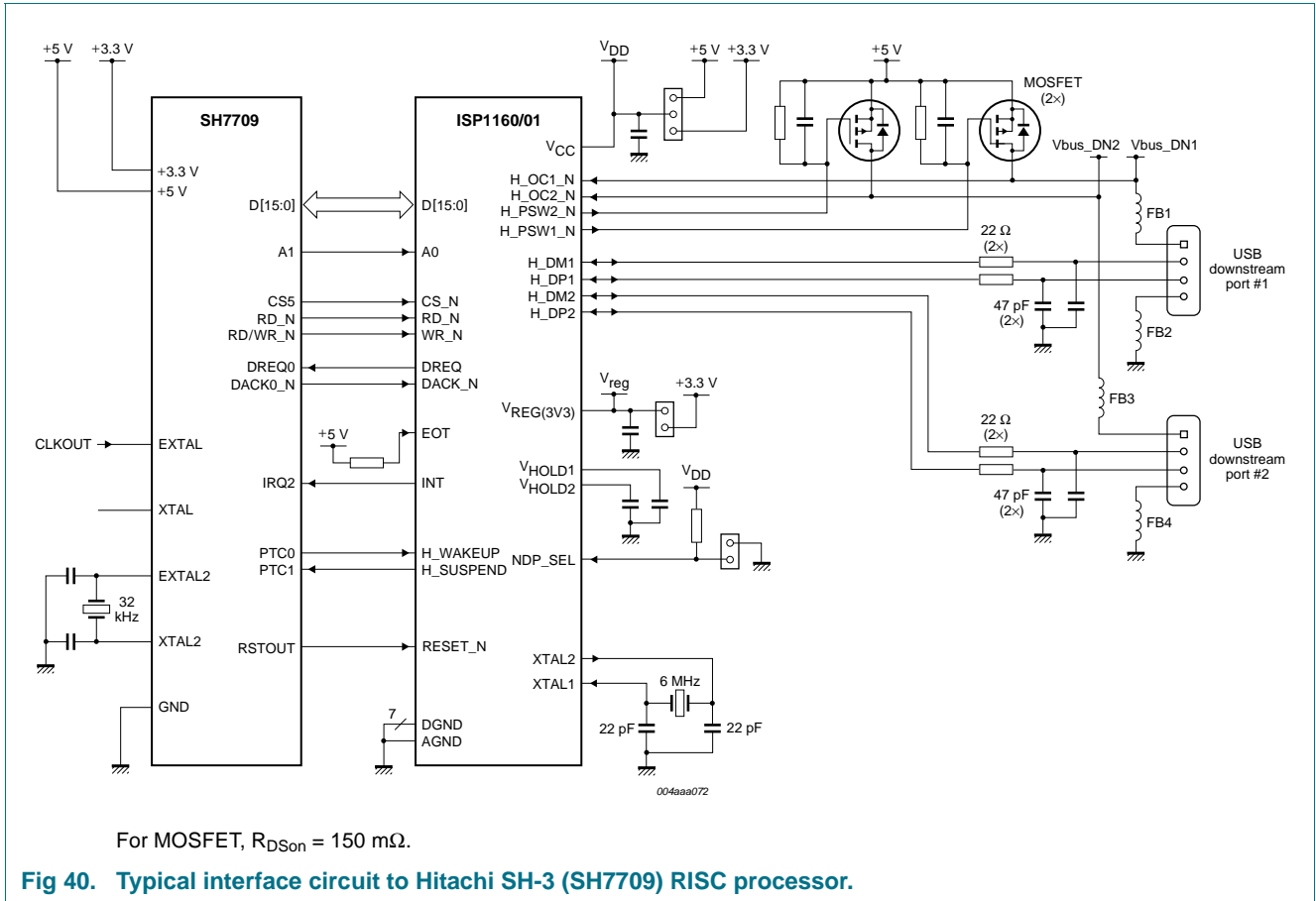

Fig 39. External EOT timing for burst mode DMA.

18. Application information

18.1 Typical interface circuit



18.2 Interfacing a ISP1160/01 to a SH7709 RISC processor

This section shows a typical interface circuit between the ISP1160/01 and a RISC processor. The Hitachi SH-3 series RISC processor SH7709 is used as the example. The main ISP1160/01 signals to be taken into consideration for connecting to a SH7709 RISC processor are:

- A 16-bit data bus: D[15:0] for the ISP1160/01. The ISP1160/01 is 'little endian' compatible.
- The address line A0 is needed for a complete addressing of the ISP1160/01 internal registers:
 - A0 = 0 will select the Data Port of the Host Controller
 - A0 = 1 will select the Command Port of the Host Controller
- The CS_N line is used for chip selection of the ISP1160/01 in a certain address range of the RISC system. This signal is active LOW.
- RD_N and WR_N are common read and write signals. These signals are active LOW.

- There is a DMA channel standard control line: DREQ and DACK_N. The DREQ signal has programmable active levels.
- An interrupt line INT is used by the HC. It has programmable level/edge and polarity (active HIGH or LOW).
- The internal 15 k Ω pull-down resistors are used for the HC's two USB downstream ports.
- The RESET_N signal is active LOW.

Remark: SH7709's system clock input is for reference only. Refer to SH7709's specification for its actual use.

The ISP1160/01 can work under either 3.3 V or 5.0 V power supply; however, its internal core works at 3.3 V. When using 3.3 V as the power supply input, the internal DC/DC regulator will be bypassed. It is best to connect all four power supply pins (V_{CC} , $V_{REG(3V3)}$, V_{HOLD1} and V_{HOLD2}) to the 3.3 V power supply (for more information, see [Section 11](#)). All of the ISP1160/01's I/O pins are 5 V-tolerant. This feature allows the ISP1160/01 the flexibility to be used in an embedded system under either a 3.3 V or a 5 V power supply.

A typical SH7709 interface circuit is shown in [Figure 40](#).

18.3 Typical software model

This section shows a typical software requirement for an embedded system that incorporates the ISP1160/01. The software model for a Digital Still Camera (DSC) is used as the example for illustration (as shown in [Figure 41](#)). The host stack provides API for Class driver and device driver, both of which provide API for application tasks for host function.

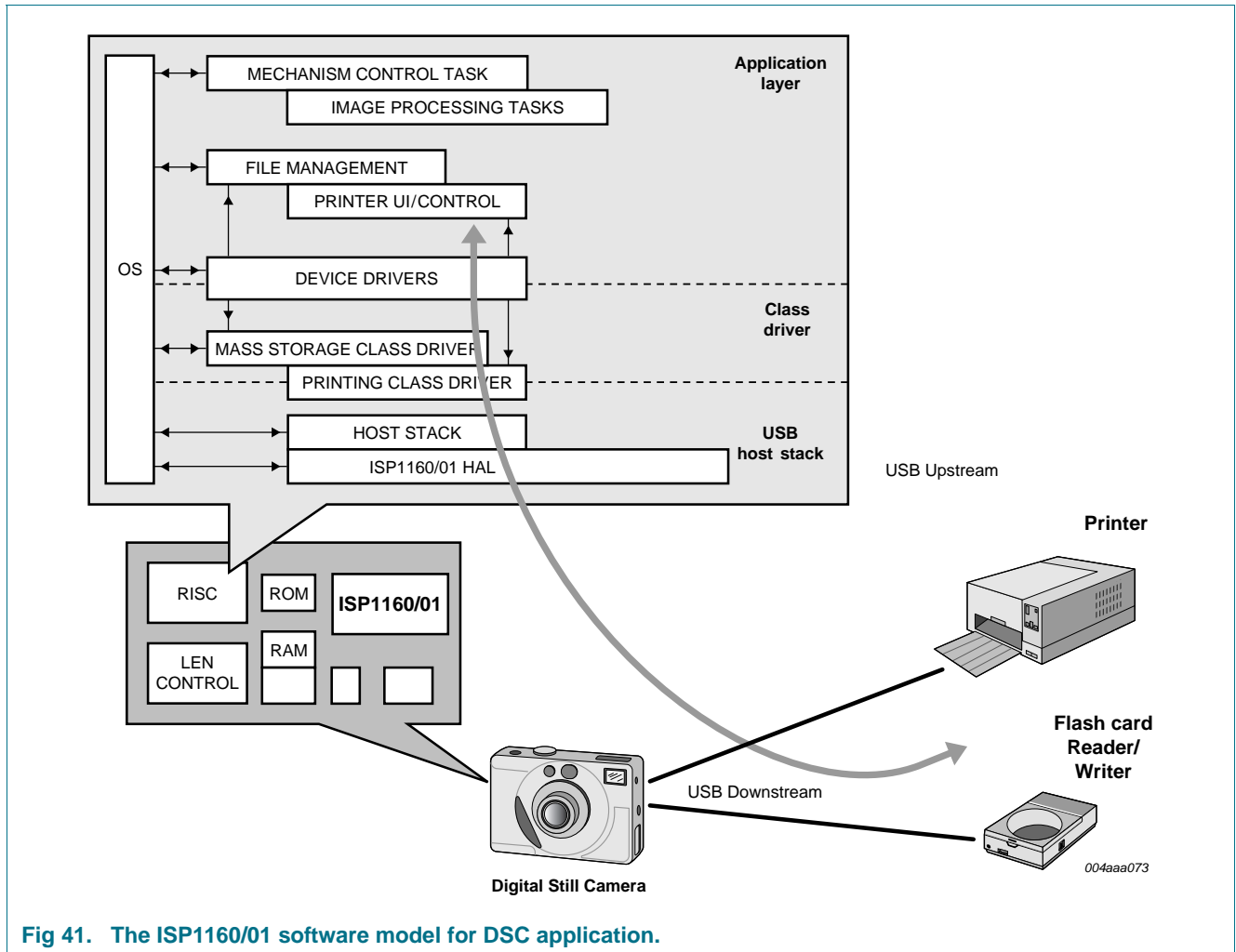

Fig 41. The ISP1160/01 software model for DSC application.

19. Test information

The dynamic characteristics of the analog I/O pins D+ and D- as listed in [Table 72](#) were determined using the circuit shown in [Figure 42](#).

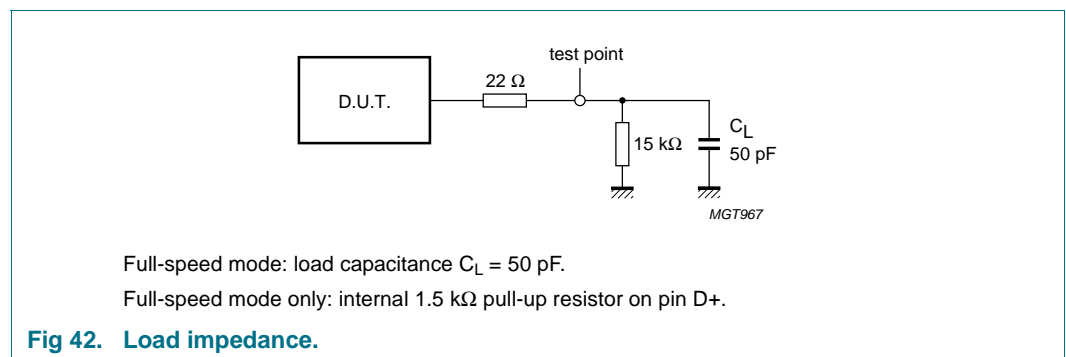

Fig 42. Load impedance.

20. Package outline

LQFP64: plastic low profile quad flat package; 64 leads; body 10 x 10 x 1.4 mm

SOT314-2

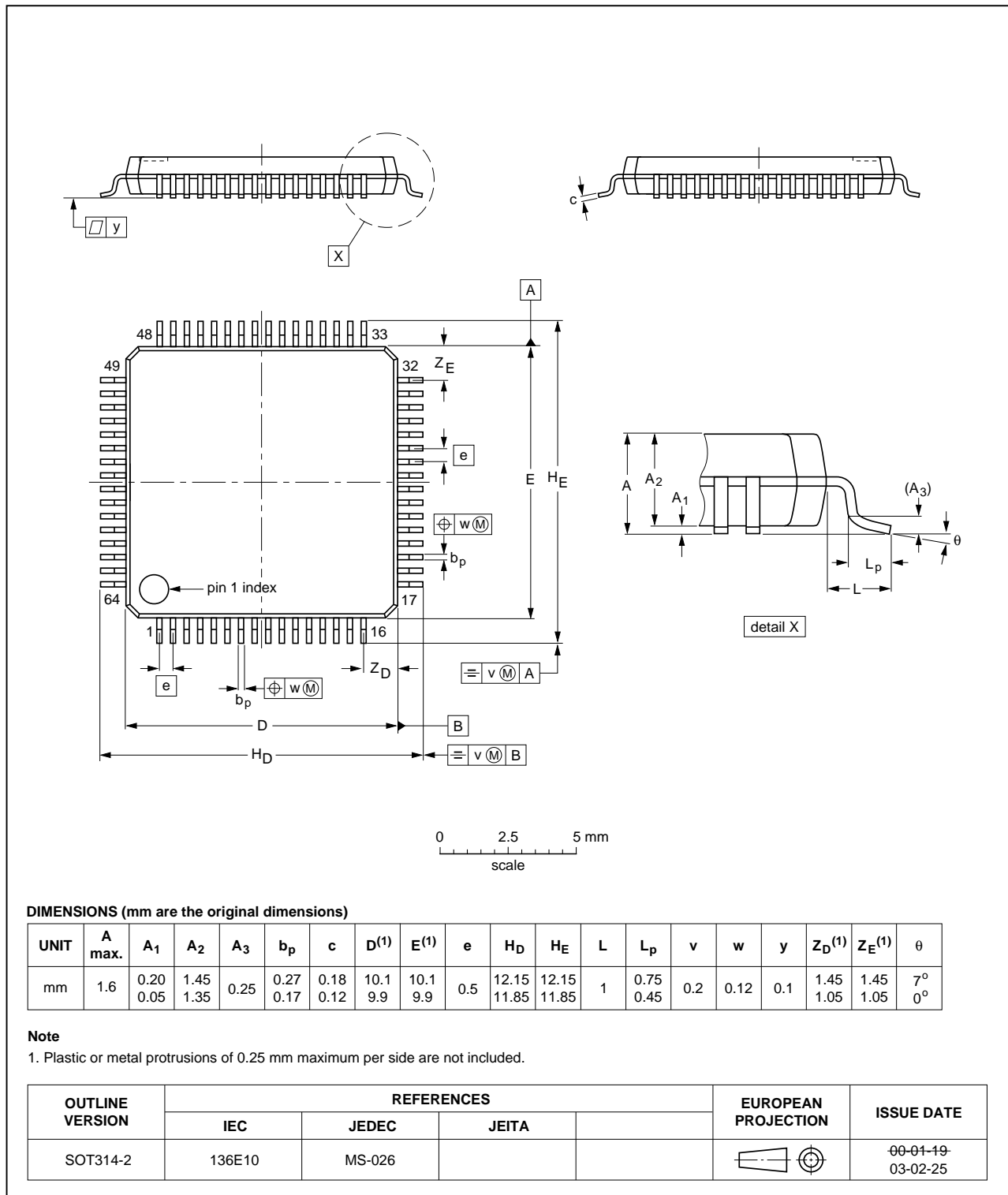

Fig 43. LQFP64 (SOT314-2) package outline.

LQFP64: plastic low profile quad flat package; 64 leads; body 7 x 7 x 1.4 mm

SOT414-1

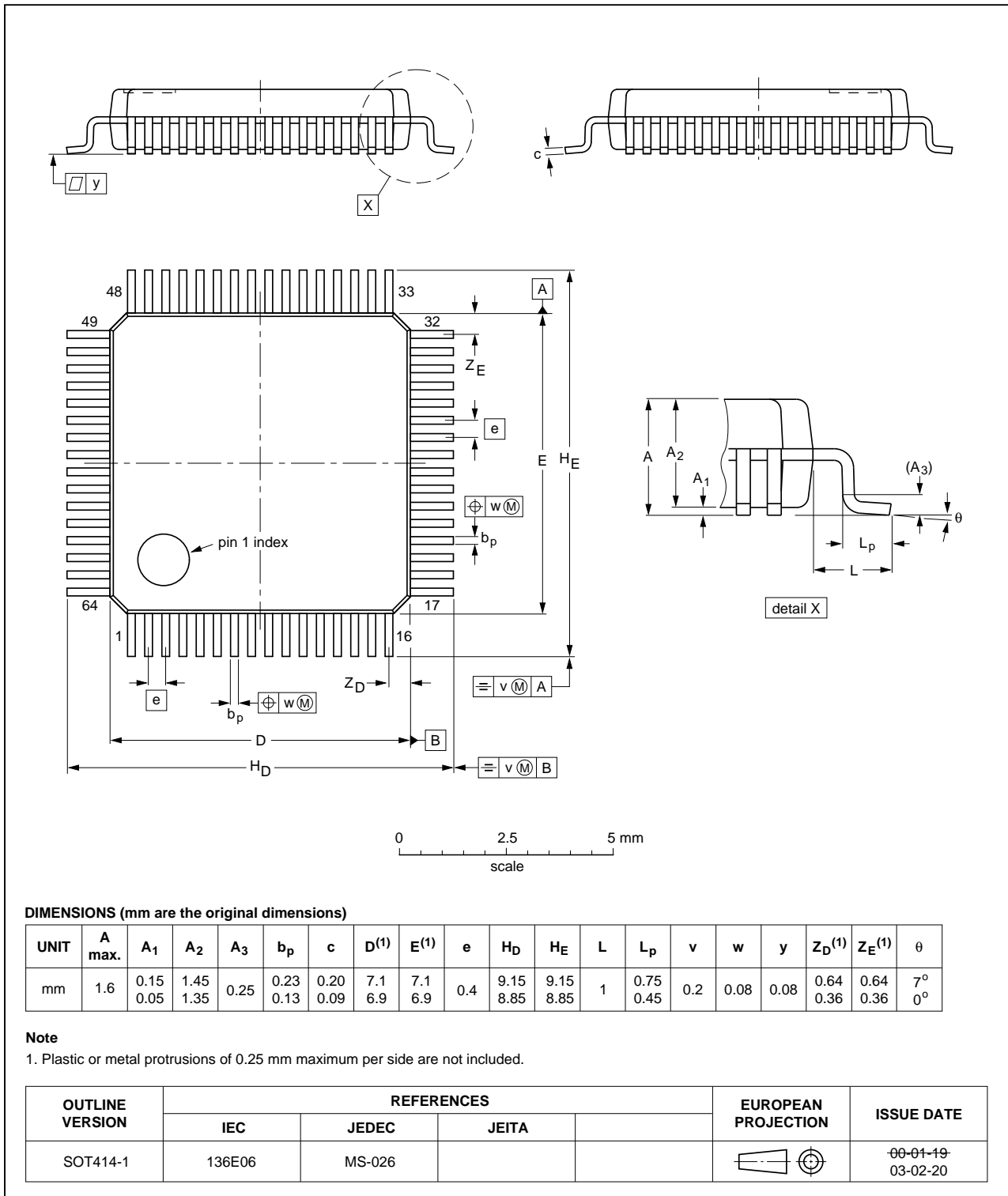

Fig 44. LQFP64 (SOT414-1) package outline.

21. Soldering of SMD packages

This text provides a very brief insight into a complex technology. A more in-depth account of soldering ICs can be found in Application Note *AN10365 “Surface mount reflow soldering description”*.

21.1 Introduction to soldering

Soldering is one of the most common methods through which packages are attached to Printed Circuit Boards (PCBs), to form electrical circuits. The soldered joint provides both the mechanical and the electrical connection. There is no single soldering method that is ideal for all IC packages. Wave soldering is often preferred when through-hole and Surface Mount Devices (SMDs) are mixed on one printed wiring board; however, it is not suitable for fine pitch SMDs. Reflow soldering is ideal for the small pitches and high densities that come with increased miniaturization.

21.2 Wave and reflow soldering

Wave soldering is a joining technology in which the joints are made by solder coming from a standing wave of liquid solder. The wave soldering process is suitable for the following:

- Through-hole components
- Leaded or leadless SMDs, which are glued to the surface of the printed circuit board

Not all SMDs can be wave soldered. Packages with solder balls, and some leadless packages which have solder lands underneath the body, cannot be wave soldered. Also, leaded SMDs with leads having a pitch smaller than ~0.6 mm cannot be wave soldered, due to an increased probability of bridging.

The reflow soldering process involves applying solder paste to a board, followed by component placement and exposure to a temperature profile. Leaded packages, packages with solder balls, and leadless packages are all reflow solderable.

Key characteristics in both wave and reflow soldering are:

- Board specifications, including the board finish, solder masks and vias
- Package footprints, including solder thieves and orientation
- The moisture sensitivity level of the packages
- Package placement
- Inspection and repair
- Lead-free soldering versus SnPb soldering

21.3 Wave soldering

Key characteristics in wave soldering are:

- Process issues, such as application of adhesive and flux, clinching of leads, board transport, the solder wave parameters, and the time during which components are exposed to the wave
- Solder bath specifications, including temperature and impurities

21.4 Reflow soldering

Key characteristics in reflow soldering are:

- Lead-free versus SnPb soldering; note that a lead-free reflow process usually leads to higher minimum peak temperatures (see [Figure 45](#)) than a SnPb process, thus reducing the process window
- Solder paste printing issues including smearing, release, and adjusting the process window for a mix of large and small components on one board
- Reflow temperature profile; this profile includes preheat, reflow (in which the board is heated to the peak temperature) and cooling down. It is imperative that the peak temperature is high enough for the solder to make reliable solder joints (a solder paste characteristic). In addition, the peak temperature must be low enough that the packages and/or boards are not damaged. The peak temperature of the package depends on package thickness and volume and is classified in accordance with [Table 76](#) and [77](#)

Table 76. SnPb eutectic process (from J-STD-020C)

Package thickness (mm)	Package reflow temperature (°C)	
	Volume (mm ³)	
	< 350	≥ 350
< 2.5	235	220
≥ 2.5	220	220

Table 77. Lead-free process (from J-STD-020C)

Package thickness (mm)	Package reflow temperature (°C)		
	Volume (mm ³)		
	< 350	350 to 2000	> 2000
< 1.6	260	260	260
1.6 to 2.5	260	250	245
> 2.5	250	245	245

Moisture sensitivity precautions, as indicated on the packing, must be respected at all times.

Studies have shown that small packages reach higher temperatures during reflow soldering, see [Figure 45](#).

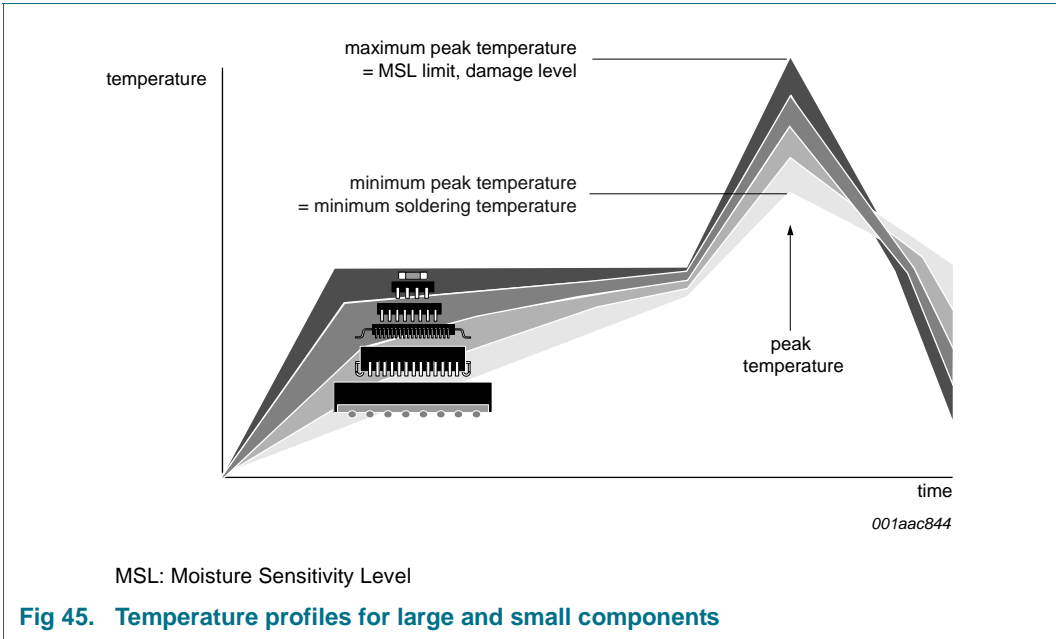

For further information on temperature profiles, refer to Application Note AN10365 “Surface mount reflow soldering description”.

22. Revision history

Table 78. Revision history

Document ID	Release date	Data sheet status	Change notice	Supersedes
ISP1160-01_6	20090128	Product data sheet	-	ISP1160-05
Modifications:	<ul style="list-style-type: none"> • Globally changed Philips Semiconductors and Philips to ST-NXP Wireless. Also updated the legal text. • Changed PTD to Proprietary Transfer Descriptor. • Removed DOD part ISP1160. 			
ISP1160-05 (9397 750 13963)	20041224	Product data	200412019	ISP1160-04
ISP1160-04 (9397 750 11371)	20030704	Product data	-	ISP1160-03
ISP1160-03 (9397 750 10765)	20030227	Product data	-	ISP1160-02
ISP1160-02 (9397 750 09628)	20020912	Product data	-	ISP1160-01
ISP1160-01 (9397 750 09161)	20020104	Objective data	-	-

23. Tables

Table 1.	Ordering information	2	Table 53.	HcITLBufferLength register: bit description	62
Table 2.	Pin description LQFP64	4	Table 54.	HcATLBufferLength register: bit allocation	63
Table 3.	I/O port addressing	10	Table 55.	HcATLBufferLength register: bit description	63
Table 4.	Proprietary Transfer Descriptor (PTD): bit allocation	19	Table 56.	HcBufferStatus register: bit allocation	63
Table 5.	Proprietary Transfer Descriptor (PTD): bit description	20	Table 57.	HcBufferStatus register: bit description	63
Table 6.	Run results of the C program example	27	Table 58.	HcReadBackITL0Length register: bit allocation	64
Table 7.	HC registers summary	35	Table 59.	HcReadBackITL0Length register: bit description	64
Table 8.	HcRevision register: bit allocation	36	Table 60.	HcReadBackITL1Length register: bit allocation	64
Table 9.	HcRevision register: bit description	37	Table 61.	HcReadBackITL1Length register: bit description	65
Table 10.	HcControl register: bit allocation	37	Table 62.	HcITLBufferPort register: bit allocation	65
Table 11.	HcControl register: bit description	38	Table 63.	HcITLBufferPort register: bit description	65
Table 12.	HcCommandStatus register: bit allocation	39	Table 64.	HcATLBufferPort register: bit allocation	66
Table 13.	HcCommandStatus register: bit description	39	Table 65.	HcATLBufferPort register: bit description	66
Table 14.	HcInterruptStatus register: bit allocation	40	Table 66.	Absolute maximum ratings	69
Table 15.	HcInterruptStatus register: bit description	40	Table 67.	Recommended operating conditions	69
Table 16.	HcInterruptEnable register: bit allocation	41	Table 68.	Static characteristics; supply pins	70
Table 17.	HcInterruptEnable register: bit description	41	Table 69.	Static characteristics: digital pins	70
Table 18.	HcInterruptDisable register: bit allocation	42	Table 70.	Static characteristics: analog I/O pins D+ and D-	71
Table 19.	HcInterruptDisable register: bit description	42	Table 71.	Dynamic characteristics	72
Table 20.	HcFmInterval register: bit allocation	43	Table 72.	Dynamic characteristics: analog I/O pins D+ and D-	72
Table 21.	HcFmInterval register: bit description	44	Table 73.	Dynamic characteristics: programmed interface timing	73
Table 22.	HcFmRemaining register: bit allocation	44	Table 74.	Dynamic characteristics: single-cycle DMA timing	74
Table 23.	HcFmRemaining register: bit description	45	Table 75.	Dynamic characteristics: burst mode DMA timing	75
Table 24.	HcFmNumber register: bit allocation	45	Table 76.	SnPb eutectic process (from J-STD-020C)	83
Table 25.	HcFmNumber register: bit description	45	Table 77.	Lead-free process (from J-STD-020C)	83
Table 26.	HcLSThreshold register: bit allocation	46	Table 78.	Revision history	85
Table 27.	HcLSThreshold register: bit description	46			
Table 28.	HcRhDescriptorA register: bit description	47			
Table 29.	HcRhDescriptorA register: bit description	48			
Table 30.	HcRhDescriptorB register: bit allocation	49			
Table 31.	HcRhDescriptorB register: bit description	49			
Table 32.	HcRhStatus register: bit allocation	50			
Table 33.	HcRhStatus register: bit description	51			
Table 34.	HcRhPortStatus[1:2] register: bit allocation	52			
Table 35.	HcRshPortStatus[1:2] register: bit description	52			
Table 36.	HcHardwareConfiguration register: bit allocation	56			
Table 37.	HcHardwareConfiguration register: bit description	56			
Table 38.	HcDMAConfiguration register: bit allocation	57			
Table 39.	HcDMAConfiguration register: bit description	57			
Table 40.	HcTransferCounter register: bit allocation	58			
Table 41.	HcTransferCounter register: bit description	58			
Table 42.	HcmPIInterrupt register: bit allocation	58			
Table 43.	HcmPIInterrupt register: bit description	59			
Table 44.	HcmPIInterruptEnable register: bit allocation	60			
Table 45.	HcmPIInterruptEnable register: bit description	60			
Table 46.	HcChipID register: bit allocation	61			
Table 47.	HcChipID register: bit description	61			
Table 48.	HcScratch register: bit allocation	61			
Table 49.	HcScratch register: bit description	61			
Table 50.	HcSoftwareReset register: bit allocation	61			
Table 51.	HcSoftwareReset register: bit description	62			
Table 52.	HcITLBufferLength register: bit allocation	62			

24. Figures

Fig 1.	Block diagram.....	3
Fig 2.	Pin configuration LQFP64.....	4
Fig 3.	Programmed I/O interface between a microprocessor and the ISP1160/01.....	9
Fig 4.	DMA interface between a microprocessor and the ISP1160/01.....	9
Fig 5.	Access to internal control registers.....	10
Fig 6.	16-bit register access cycle.....	11
Fig 7.	32-bit register access cycle.....	11
Fig 8.	Accessing HC control registers.....	11
Fig 9.	Internal FIFO buffer RAM access cycle.....	12
Fig 10.	DMA transfer in single-cycle mode.....	13
Fig 11.	DMA transfer in burst mode.....	13
Fig 12.	Interrupt pin operating modes.....	14
Fig 13.	HC interrupt logic.....	15
Fig 14.	The ISP1160/01 HC's USB states.....	16
Fig 15.	ISP1160/01 HC USB transaction loop.....	17
Fig 16.	PTD data in FIFO buffer RAM.....	19
Fig 17.	HC internal FIFO buffer RAM partitions.....	22
Fig 18.	Buffer RAM data organization.....	23
Fig 19.	PTD data with DWORD alignment in buffer RAM.....	24
Fig 20.	PIO access to internal FIFO buffer RAM.....	25
Fig 21.	HC time domain behavior: example 1.....	29
Fig 22.	HC time domain behavior: example 2.....	30
Fig 23.	HC time domain behavior: example 3.....	30
Fig 24.	Use of 15 kW pull-down resistors on downstream ports.....	31
Fig 25.	Downstream port power management scheme.....	31
Fig 26.	Using an internal OC detection circuit.....	32
Fig 27.	Using an external OC detection circuit.....	33
Fig 28.	ISP1160/01 suspend and resume clock scheme.....	34
Fig 29.	Using a 5 V supply.....	67
Fig 30.	Using a 3.3 V supply.....	67
Fig 31.	Oscillator circuit with external crystal.....	67
Fig 32.	Oscillator circuit using external oscillator.....	67
Fig 33.	Internal POR timing.....	68
Fig 34.	Clock with respect to the external POR.....	68
Fig 35.	Programmed interface timing.....	74
Fig 36.	Single-cycle DMA timing.....	75
Fig 37.	Burst mode DMA timing.....	76
Fig 38.	External EOT timing for single-cycle DMA.....	76
Fig 39.	External EOT timing for burst mode DMA.....	76
Fig 40.	Typical interface circuit to Hitachi SH-3 (SH7709) RISC processor.....	77
Fig 41.	The ISP1160/01 software model for DSC application.....	79
Fig 42.	Load impedance.....	79
Fig 43.	LQFP64 (SOT314-2) package outline.....	80
Fig 44.	LQFP64 (SOT414-1) package outline.....	81
Fig 45.	Temperature profiles for large and small components.....	84

25. Contents

1	General description	1	9.9.2.1	Wake-up by pin H_WAKEUP	34
2	Features	1	9.9.2.2	Wake-up by pin CS_N (software wake-up) . .	35
3	Applications	2	9.9.2.3	Wake-up by USB devices	35
4	Ordering information	2	10	HC registers	35
5	Block diagram	3	10.1	HC control and status registers	36
6	Pinning information	4	10.1.1	HcRevision register (R: 00H)	36
6.1	Pinning	4	10.1.2	HcControl register (R/W: 01H/81H)	37
6.2	Pin description	4	10.1.3	HcCommandStatus register (R/W: 02H/82H) .	38
7	Functional description	8	10.1.4	HcInterruptStatus register (R/W: 03H/83H) . .	39
7.1	PLL clock multiplier	8	10.1.5	HcInterruptEnable register (R/W: 04H/84H) . .	40
7.2	Bit clock recovery	8	10.1.6	HcInterruptDisable register (R/W: 05H/85H) .	42
7.3	Analog transceivers	8	10.2	HC frame counter registers	43
7.4	ST-NXP Wireless Serial Interface Engine (SIE)	8	10.2.1	HcFmInterval register (R/W: 0DH/8DH)	43
8	Microprocessor bus interface	8	10.2.2	HcFmRemaining register (R: 0EH)	44
8.1	Programmed I/O (PIO) addressing mode	8	10.2.3	HcFmNumber register (R: 0FH)	45
8.2	DMA mode	9	10.2.4	HcLSThreshold register (R/W: 11H/91H)	46
8.3	Control registers access by PIO mode	10	10.3	HC Root Hub registers	46
8.3.1	I/O port addressing	10	10.3.1	HcRhDescriptorA register (R/W: 12H/92H) . .	47
8.3.2	Register access phases	10	10.3.2	HcRhDescriptorB register (R/W: 13H/93H) . .	48
8.4	FIFO buffer RAM access by PIO mode	11	10.3.3	HcRhStatus register (R/W: 14H/94H)	49
8.5	FIFO buffer RAM access by DMA mode	12	10.3.4	HcRhPortStatus[1:2] (R/W [1]:15H/95H, [2]:	51
8.6	Interrupts	13		16H/96H)	51
8.6.1	Pin configuration	13	10.4	HC DMA and interrupt control registers	55
8.6.2	Interrupt output pin (INT)	14	10.4.1	HcHardwareConfiguration register (R/W:	55
9	Host Controller (HC)	16		20H/A0H)	55
9.1	HC's four USB states	16	10.4.2	HcDMAConfiguration register (R/W: 21H/A1H)	57
9.2	Generating USB traffic	17	10.4.3	HcTransferCounter register (R/W: 22H/A2H) .	57
9.3	PTD data structure	18	10.4.4	HcmPIInterrupt register (R/W: 24H/A4H)	58
9.3.1	PTD data header definition	19	10.4.5	HcmPIInterruptEnable register	59
9.4	HC's internal FIFO buffer RAM structure . . .	21		(R/W: 25H/A5H)	59
9.4.1	Partitions	21	10.5	HC miscellaneous registers	60
9.4.2	Data organization	23	10.5.1	HcChipID register (R: 27H)	60
9.4.3	Operation and C program example	24	10.5.2	HcScratch register (R/W: 28H/A8H)	61
9.5	HC operational model	28	10.5.3	HcSoftwareReset register (W: A9H)	61
9.5.1	Time domain behavior	29	10.6	HC buffer RAM control registers	62
9.5.2	Control transaction limitations	30	10.6.1	HcITLBufferLength register (R/W: 2AH/AAH) .	62
9.6	Microprocessor loading	30	10.6.2	HcATLBufferLength register (R/W: 2BH/ABH) .	62
9.7	Internal pull-down resistors for downstream	30	10.6.3	HcBufferStatus register (R: 2CH)	63
	ports	30	10.6.4	HcReadBackITL0Length register (R: 2DH) . .	64
9.8	Overcurrent detection and power switching	31	10.6.5	HcReadBackITL1Length register (R: 2EH) . .	64
	control	31	10.6.6	HcITLBufferPort register (R/W: 40H/C0H) . . .	65
9.8.1	Using an internal OC detection circuit	32	10.6.7	HcATLBufferPort register (R/W: 41H/C1H) . .	65
9.8.2	Using an external OC detection circuit	33	11	Power supply	67
9.9	Suspend and wake-up	33	12	Crystal oscillator	67
9.9.1	HC suspended state	33	13	Power-on reset (POR)	68
9.9.2	HC wake-up from suspended state	34	14	Limiting values	69
			15	Recommended operating conditions	69

continued >>

16	Static characteristics	70
17	Dynamic characteristics	72
17.1	Programmed I/O timing	73
17.2	DMA timing	74
17.2.1	Single-cycle DMA timing	74
17.2.2	Burst mode DMA timing	75
17.2.3	External EOT timing for single-cycle DMA SETUP	76
17.2.4	External EOT timing for burst mode DMA . . .	76
18	Application information	77
18.1	Typical interface circuit	77
18.2	Interfacing a ISP1160/01 to a SH7709 RISC processor	77
18.3	Typical software model	78
19	Test information	79
20	Package outline	80
21	Soldering of SMD packages	82
21.1	Introduction to soldering	82
21.2	Wave and reflow soldering	82
21.3	Wave soldering	82
21.4	Reflow soldering	83
22	Revision history	85
23	Tables	86
24	Figures	87
25	Contents	88

Please be aware that important notices concerning this document and the product(s) described herein, have been included in section 'Legal information'.

© ST-NXP Wireless 2009.

All rights reserved.

For more information, please visit: <http://www.stnwireless.com>

Date of release: 28 January 2009
Document identifier: ISP1160-01_6