

SERIAL LINK INTERFACE

USER GUIDE

MODEL ILPH RS 422 - RS 485 / RS 422 - RS 485

Part/Number	Black body ENT	0084 212.14
	Grey body ABB V0	1SNA 684 212 R2200

1. GENERAL

Interface between an RS 422 - RS 485 (1 or 2 pairs) and an RS 422 - RS 485 (1 or 2 pairs) with 500 V DC insulation.

Amplifies the RS 422 - RS 485 signal in order to extend transmission distance beyond the 1200 m limit of the RS 422/485 standard. A minimum of 1,5 character delay time is needed by the ILPH to switch off the RS 485 drivers.

2. SCHEMATIC DIAGRAM

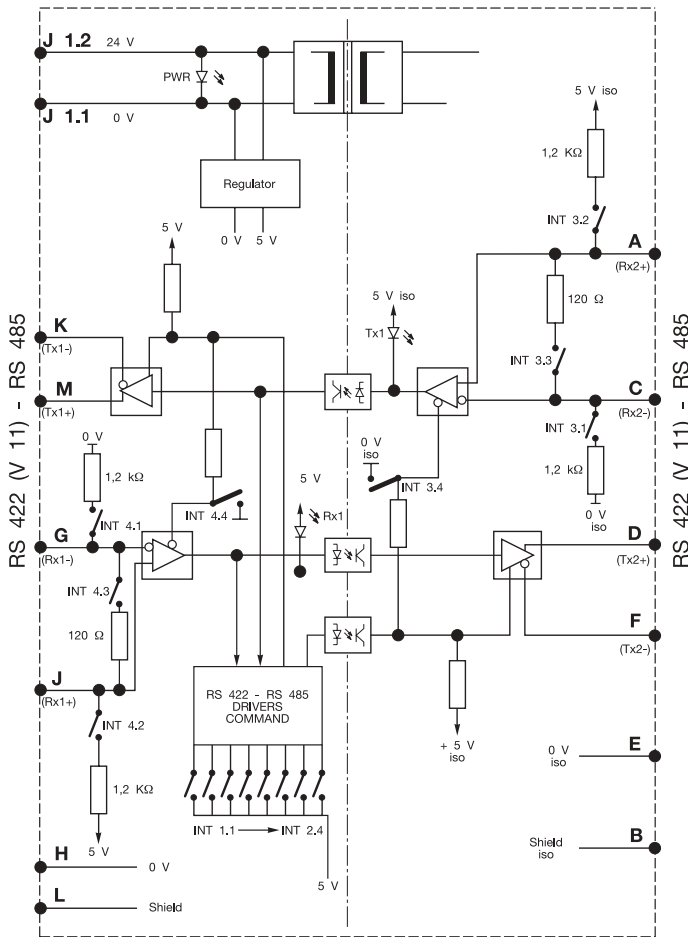

3. TECHNICAL SPECIFICATIONS

3.1 POWER SUPPLY

- Power supply voltage : 20,4 V to 28,8 V DC
- Protection : over voltage
- Power requirement : 120 mA max.
- Galvanic insulation : Power supply / RS 422 - RS 485 iso : 500 V DC
- 1 yellow "Power On" DEL.
- Screw-type plug-in connector.

3.2 RS 422 - RS 485 (1) LINK

- EIA RS 485 and compatible RS 422 / CCITT V11
- I / O protection : over-voltage

- Baud rate : from 1,2 Kb to 500 Kb.
- Baud rate / Distance: 38400 Bauds / 1200 m
- Galvanic insulation : RS 422 - RS 485 (1) / RS 422 - RS 485 (2) : 500 V DC
- RS 485 Drivers control : turn off delay : 1,5 character time from 27 μs to 10 ms depending on baud rate choice.
- Transmitter can communicate with up to 32 receivers simultaneously.
- Clamp connection.

3.3 RS 422 - RS 485 (2) LINK

- EIA RS 485 and compatible RS 422 / CCITT V11
- I / O protection : over-voltage
- Baud rate : from 1,2 Kb to 500 Kb.
- Baud rate / Distance : 38400 Bauds / 1200m
- Galvanic insulation : RS 422 - RS 485 / Power supply : 500 V DC
- RS 422 - RS 485 (1) / RS 422 - RS 485 (2) : 500 V DC
- RS 485 Drivers control : turn off delay : 1,5 character time from 27 μs to 10 ms depending on baud rate choice.
- Transmitter can communicate with up to 32 receivers simultaneously.
- Screw connection.

3.4 PHYSICAL CHARACTERISTICS

- Box series 11000 ABB Entrelec snaps on to DIN rail
- Temperature : operation : 0 to 50°C
- storage : - 20 to 70°C

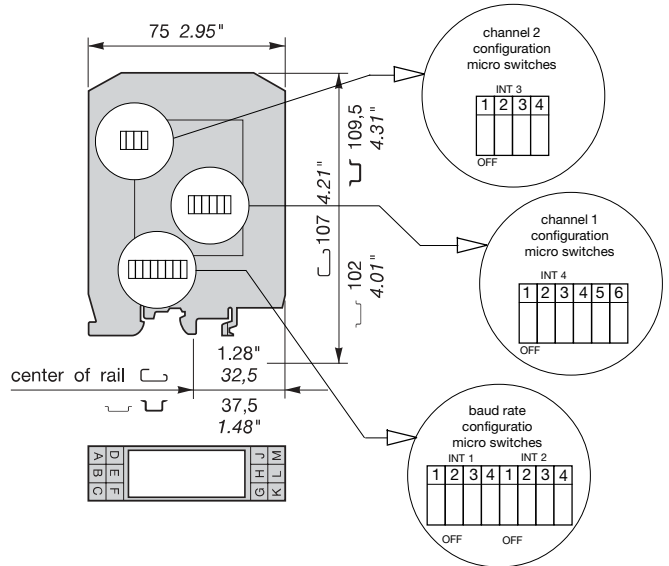

4. CONFIGURATION

4.1 BAUD RATE

By using the 8 micro switches inside the box.

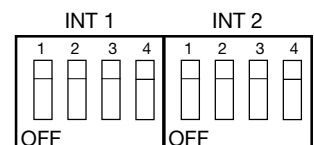

They allow to define up to 8 transmission speeds and to select the Full Duplex operation mode (RS422 / RS422) in addition with the INT 3,4, INT 4.4 and INT 4.5 micro switches.

BAUD RATE	INT 1				INT 2				INT 3				INT 4					
	1	2	3	4	1	2	3	4	1	2	3	4	1	2	3	4	5	6
FULL DUPLEX	0	0	0	0	0	0	0	0	X	X	X	1	X	X	X	1	0	1
500 Kb/s	1	1	1	1	1	1	1	1	X	X	X	0	X	X	X	0	0	0
187,5 Kb/s	1	1	1	1	1	1	1	0	X	X	X	0	X	X	X	0	0	0
93,75 Kb/s	1	1	1	1	1	1	0	0	X	X	X	0	X	X	X	0	0	0
38,4 Kb/s	1	1	1	1	1	0	0	0	X	X	X	0	X	X	X	0	0	0
19,2 Kb/s	1	1	1	1	0	0	0	0	X	X	X	0	X	X	X	0	0	0
9,6 Kb/s	1	1	1	0	0	0	0	0	X	X	X	0	X	X	X	0	0	0
4,8 Kb/s	1	1	0	0	0	0	0	0	X	X	X	0	X	X	X	0	0	0
2,4 Kb/s	1	0	0	0	0	0	0	0	X	X	X	0	X	X	X	0	0	0
1,2 Kb/s	0	0	0	0	0	0	0	0	X	X	X	0	X	X	X	0	0	0

Nu : not used
 X null
 1 closed contact
 0 open contact (off)

4.2 RS 422 - RS 485 (1) and (2) LINKS

4.2.1 RS 422 - RS 485 DRIVERS CONTROL

The RS 422 - RS 485 Drivers Control (transmitters and receivers) allows the ILPH to be easy to use. The control of the 2 channels is entirely automatic and simply need to configure the baud rate used. The minimum turn off delay is about 1,5 character time from 27 µs to 10 ms depending band rate selected.

4.2.2 POLARIZATION OF THE RS 422 - RS 485 LINES

The line must always be polarized. The ILPH is used to polarize the reception channels :

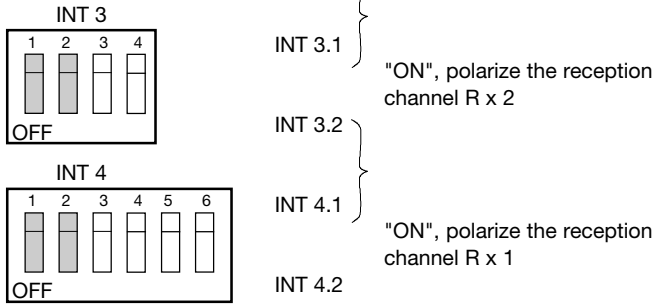

4.2.3 ADAPTING THE RS 422 - RS 485 LINES

The line must always be adapted to the level of the reception channel of each subscriber forming the end of the bus.

The ILPH is used to adapt the reception channel by setting the micro switch INT 3.3 and INT 4.3.

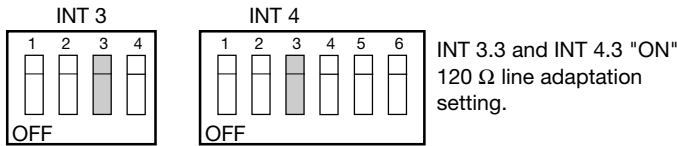

5. CONNECTIONS

Connections example with 2 products RS 485 on 1 and 2 pairs.

RS 422 - RS 485 LINK ON 1 PAIR

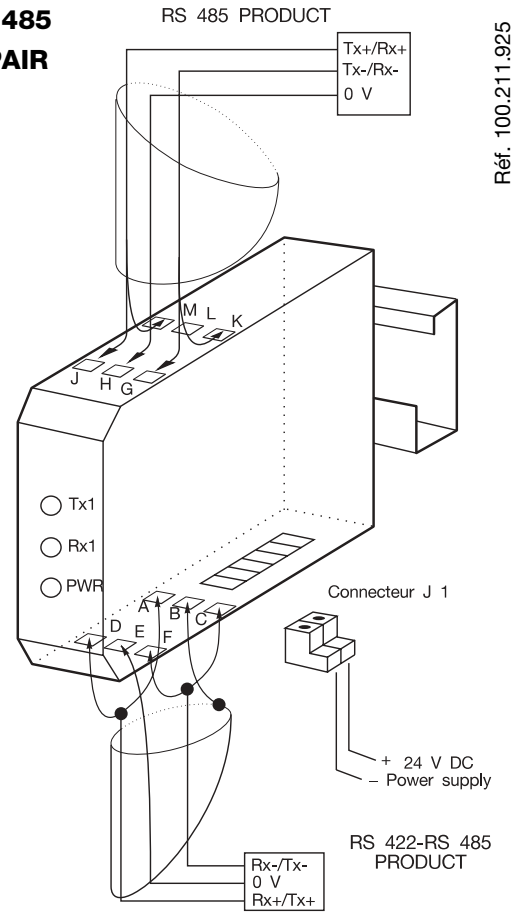

RS 422 - RS 485 LINK ON 2 PAIRS

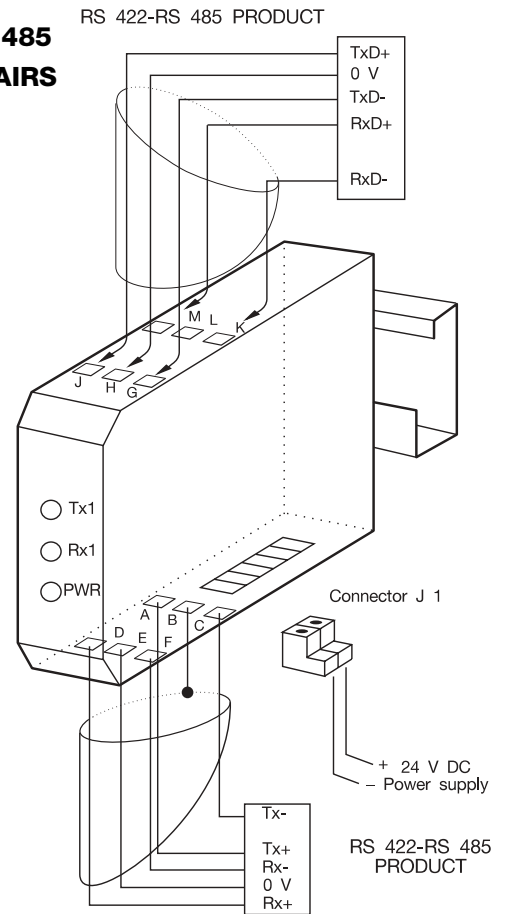

NOTA : The transmitters channels of the 2 RS 422 - RS 485 links must always independently be polarized.