

# DATA SHEET

For a complete data sheet, please also download:

- The IC04 LOCMOS HE4000B Logic Family Specifications HEF, HEC
- The IC04 LOCMOS HE4000B Logic Package Outlines/Information HEF, HEC

## **HEF4894B**

12-stage shift-and-store register

LED driver

Product specification  
File under Integrated Circuits, IC04

January 1995

# 12-stage shift-and-store register LED driver

# HEF4894B

### APPLICATIONS

- Automotive
- Industrial

### GENERAL DESCRIPTION

The HEF4894B is a 12 stage serial shift register having a storage latch associated with each stage for strobing data from the serial input to parallel LED driver outputs  $O_0$  to  $O_{11}$ . Data is shifted on positive-going clock transitions. The data in each shift register stage is transferred to the storage register when the strobe (STR) input is HIGH. Data in the storage register appears at the outputs whenever the output enable (EO) signal is HIGH.

Two serial outputs ( $O_s$  and  $O_s'$ ) are available for cascading a number of HEF4894B devices. Data is available at  $O_s$  on positive-going clock edges to allow high-speed operation in cascaded systems in which the clock rise time is fast. The same serial information is available at  $O_s'$  on the next negative-going clock edge and provides cascading HEF4894B devices when the clock rise time is slow.

### ORDERING AND PACKAGE INFORMATION

TYPE NUMBER	PACKAGES			
	PINS	PIN POSITION	MATERIAL	CODE
HEF4894BT	20	SO	plastic	SO20/SOT163A
HEF4894BP	20	DIL	plastic	DIL20/SOT146

### PINNING

PIN	SYMBOL	NAME AND FUNCTION
1	STR	strobe input
2	D	data input
3	CP	clock input
4, 5, 6, 7, 8, 9, 18, 17, 16, 15, 14, 13	$O_0$ to $O_{11}$	parallel outputs (open drain)
10	$V_{SS}$	ground
11, 12	$O_s, O_s'$	serial outputs
19	EO	output enable input
20	$V_{DD}$	positive supply voltage

### FAMILY DATA

See Family Specifications except for:  
 Rating for DC current into any open-drain output: 40 mA.

**$I_{DD}$  LIMITS category MSI:** see Family Specifications.

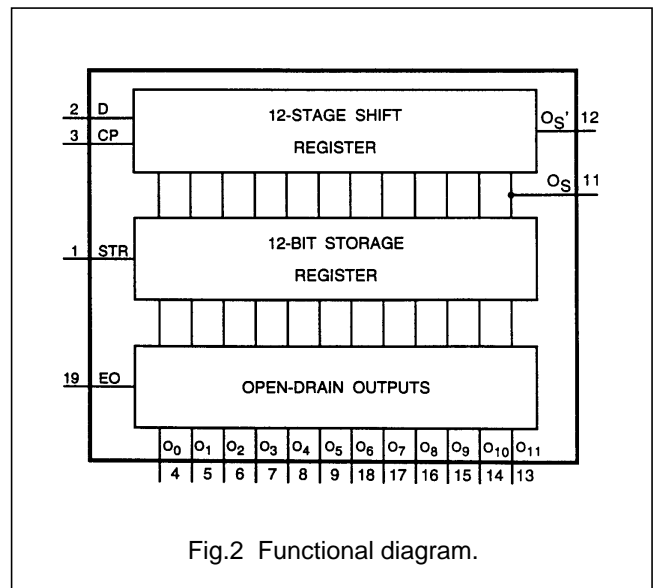
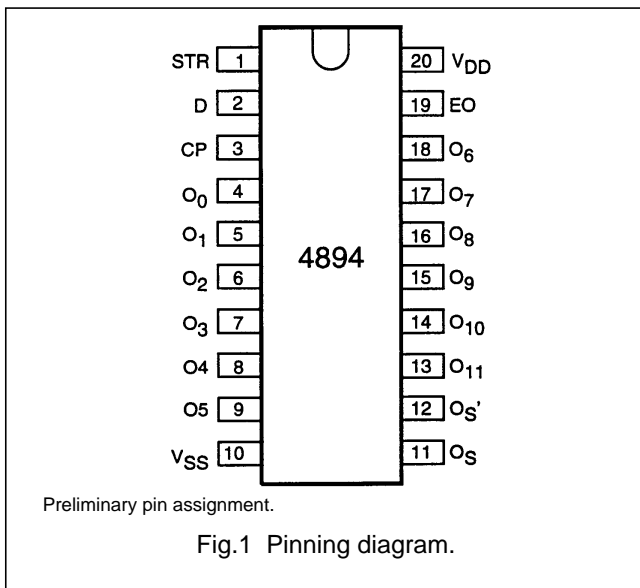

12-stage shift-and-store register LED driver

HEF4894B

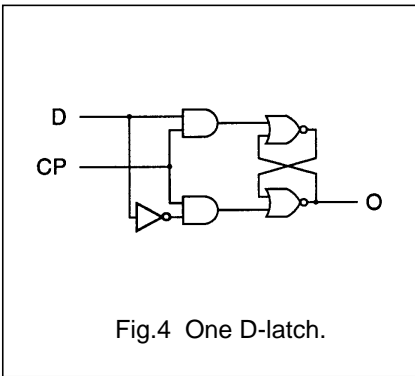
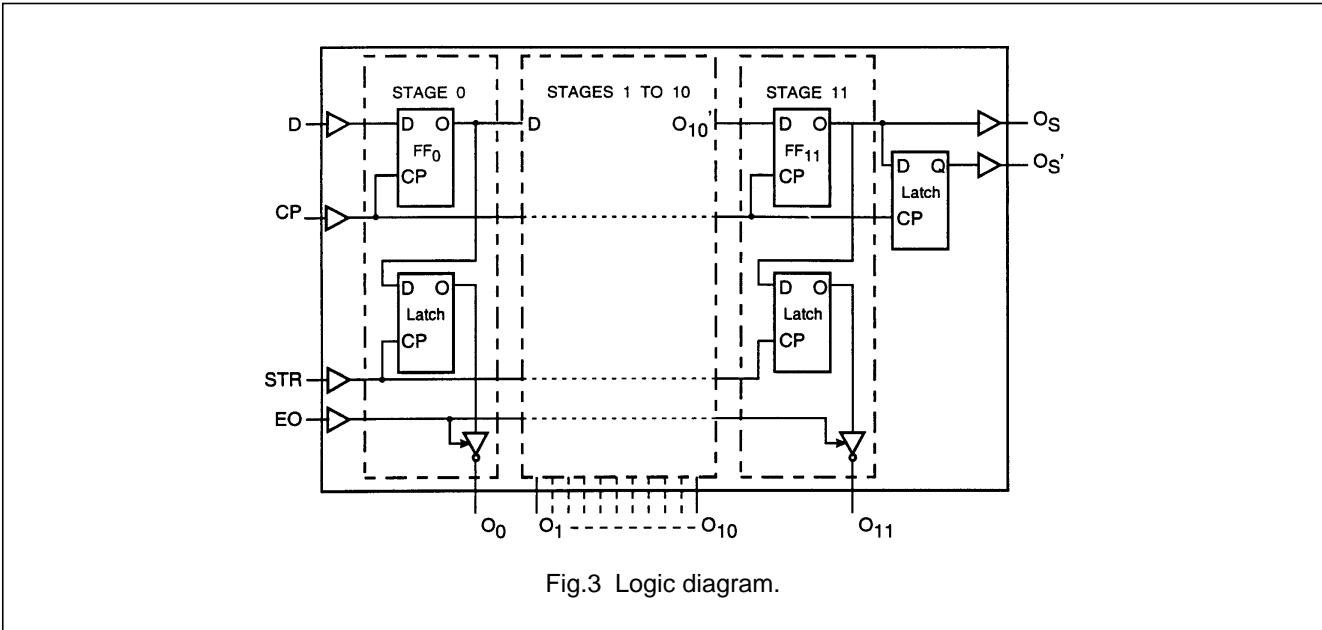

**FUNCTION TABLE**

INPUTS				PARALLEL OUTPUTS		SERIAL OUTPUTS	
CP	EO	STR	D	O <sub>0</sub>	O <sub>n</sub>	O <sub>s</sub>	O <sub>s</sub> '
↑	L	X	X	Z	Z	O <sub>10</sub> '	nc
↓	L	X	X	Z	Z	nc	O <sub>11</sub>
↑	H	L	X	nc	nc	O <sub>10</sub> '	nc
↑	H	H	L	Z	O <sub>n-1</sub>	O <sub>10</sub> '	nc
↑	H	H	H	L	O <sub>n-1</sub>	O <sub>10</sub> '	nc
↓	H	H	H	nc	nc	nc	O <sub>11</sub>

**Notes**

1. H = HIGH state (the more positive voltage)
2. L = LOW state (the less positive voltage)
3. X = state is immaterial
4. ↑ = positive-going transition
5. ↓ = negative-going transition
6. Z = high impedance OFF state
7. nc = no change
8. O<sub>11</sub>' = the information in the twelfth shift register stage.

At the positive clock edge the information in the 10<sup>th</sup> register stage is transferred to the 11<sup>th</sup> register stage and the O<sub>s</sub> output.

## 12-stage shift-and-store register LED driver

HEF4894B

## DC CHARACTERISTICS

 $V_{SS} = 0$  V.

PARAMETER	$V_{DD}$ (V)	SYMBOL	$T_{amb}$ (°C)						UNIT	CONDITIONS
			-40		+ 25		+ 85			
			MIN.	MAX.	MIN.	MAX.	MIN.	MAX.		
output voltage LOW; $O_n$	5	$V_{OL}$	–	0.75	–	0.75	–	1.5	V	$V_I = V_{SS}$ or $V_{DD}$ ; $ I_o  < 20$ mA
	10		–	0.75	–	0.75	–	1.5		
	15		–	0.75	–	0.75	–	1.5		
output leakage current; HIGH; $O_n$	5	$I_{OZH}$	–	2	–	2	–	15	$\mu$ A	$V_o = 15$ V
	10		–	2	–	2	–	15		
	15		–	2	–	2	–	15		

## AC CHARACTERISTICS

 $V_{SS} = 0$  V;  $T_{amb} = 25$  °C; input transition times  $\leq 20$  ns.

PARAMETER	$V_{DD}$ (V)	TYPICAL FORMULA FOR P ( $\mu$ W)	
Dynamic power dissipation per package (P)	5	$1200 f_i + \sum(f_o C_L) \times V_{DD}^2$	where: $R_{load} = \infty$ $f_i$ = input frequency (MHz), $f_o$ = output frequency (MHz), $C_L$ = load capacitance (pF), $\sum(f_o C_L)$ = sum of outputs $V_{DD}$ = supply voltage (V)
	10	$5550 f_i + \sum(f_o C_L) \times V_{DD}^2$	
	15	$15000 f_i + \sum(f_o C_L) \times V_{DD}^2$	

## AC CHARACTERISTICS

 $V_{SS} = 0$  V;  $T_{amb} = 25$  °C;  $C_L = 50$  pF; input transition times  $\leq 20$  ns.

PARAMETER	$V_{DD}$ (V)	SYMBOL	TYP.	MAX.	UNIT	TYPICAL EXTRAPOLATION FORMULA
Propagation delay CP to $O_s$ HIGH to LOW	5	$t_{PHL}$	160	320	ns	$132$ ns + (0.55 ns/pF) $C_L$
	10		65	130		$53$ ns + (0.23 ns/pF) $C_L$
	15		45	90		$37$ ns + (0.16 ns/pF) $C_L$
Propagation delay CP to $O_s$ LOW to HIGH	5	$t_{PLH}$	130	260	ns	$102$ ns + (0.55 ns/pF) $C_L$
	10		55	110		$44$ ns + (0.23 ns/pF) $C_L$
	15		40	80		$32$ ns + (0.16 ns/pF) $C_L$
Propagation delay CP to $O_s'$ HIGH to LOW	5	$t_{PHL}$	120	240	ns	$92$ ns + (0.55 ns/pF) $C_L$
	10		50	100		$39$ ns + (0.23 ns/pF) $C_L$
	15		40	80		$32$ ns + (0.16 ns/pF) $C_L$
Propagation delay CP to $O_s'$ LOW to HIGH	5	$t_{PLH}$	130	260	ns	$102$ ns + (0.55 ns/pF) $C_L$
	10		60	120		$49$ ns + (0.23 ns/pF) $C_L$
	15		45	90		$37$ ns + (0.16 ns/pF) $C_L$

## 12-stage shift-and-store register LED driver

HEF4894B

PARAMETER	V <sub>DD</sub> (V)	SYMBOL	TYP.	MAX.	UNIT	TYPICAL EXTRAPOLATION FORMULA
Propagation delay CP to O <sub>n</sub>	5	t <sub>PZL</sub>	240	480	ns	see note 1
OFF to LOW	10		80	160		
	15		55	110		
Propagation delay CP to O <sub>n</sub>	5	t <sub>PLZ</sub>	170	340	ns	see note 1
LOW to OFF	10		75	150		
	15		60	120		
Propagation delay STR to O <sub>n</sub>	5	t <sub>PZL</sub>	140	280	ns	see note 1
OFF to LOW	10		70	140		
	15		55	110		
Propagation delay STR to O <sub>n</sub>	5	t <sub>PLZ</sub>	100	200	ns	see note 1
LOW to OFF	10		40	100		
	15		35	70		
Output transition time; O <sub>s</sub> , O <sub>s</sub> '	5	t <sub>THL</sub>	85	170	ns	35 ns + (1.0 ns/pF) C <sub>L</sub>
HIGH to LOW	10		40	80		19 ns + (0.42 ns/pF) C <sub>L</sub>
	15		30	60		16 ns + (0.28 ns/pF) C <sub>L</sub>
Output transition time; O <sub>s</sub> , O <sub>s</sub> '	5	t <sub>TLH</sub>	85	170	ns	35 ns + (1.0 ns/pF) C <sub>L</sub>
LOW to HIGH	10		40	80		19 ns + (0.42 ns/pF) C <sub>L</sub>
	15		30	60		16 ns + (0.28 ns/pF) C <sub>L</sub>

**Note**

1. Definition of symbol equivalent to 3-state outputs.

**AC CHARACTERISTICS**

V<sub>SS</sub> = 0 V; T<sub>amb</sub> = 25 °C; C<sub>L</sub> = 50 pF; input transition times ≤ 20 ns.

PARAMETER	V <sub>DD</sub> (V)	SYMBOL	MIN.	TYP.	MAX.	UNIT
output enable time EO to O <sub>n</sub>	5	t <sub>PZL</sub>	–	100	200	ns
OFF to LOW	10		–	55	110	
	15		–	50	100	
output disable time EO to O <sub>n</sub>	5	t <sub>PLZ</sub>	–	80	160	ns
LOW to OFF	10		–	40	80	
	15		–	30	60	
minimum clock pulse width LOW	5	t <sub>WCPL</sub>	60	30	–	ns
	10		30	15	–	
	15		24	12	–	
minimum strobe pulse width HIGH	5	t <sub>WSTRH</sub>	80	40	–	ns
	10		60	30	–	
	15		24	12	–	

12-stage shift-and-store register LED driver

HEF4894B

PARAMETER	V <sub>DD</sub> (V)	SYMBOL	MIN.	TYP.	MAX.	UNIT
set-up time D to CP	5	t <sub>su</sub>	60	30	–	ns
	10		20	10	–	
	15		15	5	–	
hold time D to CP	5	t <sub>hold</sub>	5	–15	–	ns
	10		20	5	–	
	15		20	5	–	
Maximum clock pulse frequency	5	f <sub>max</sub>	5	10	–	MHz
	10		11	22	–	
	15		14	28	–	

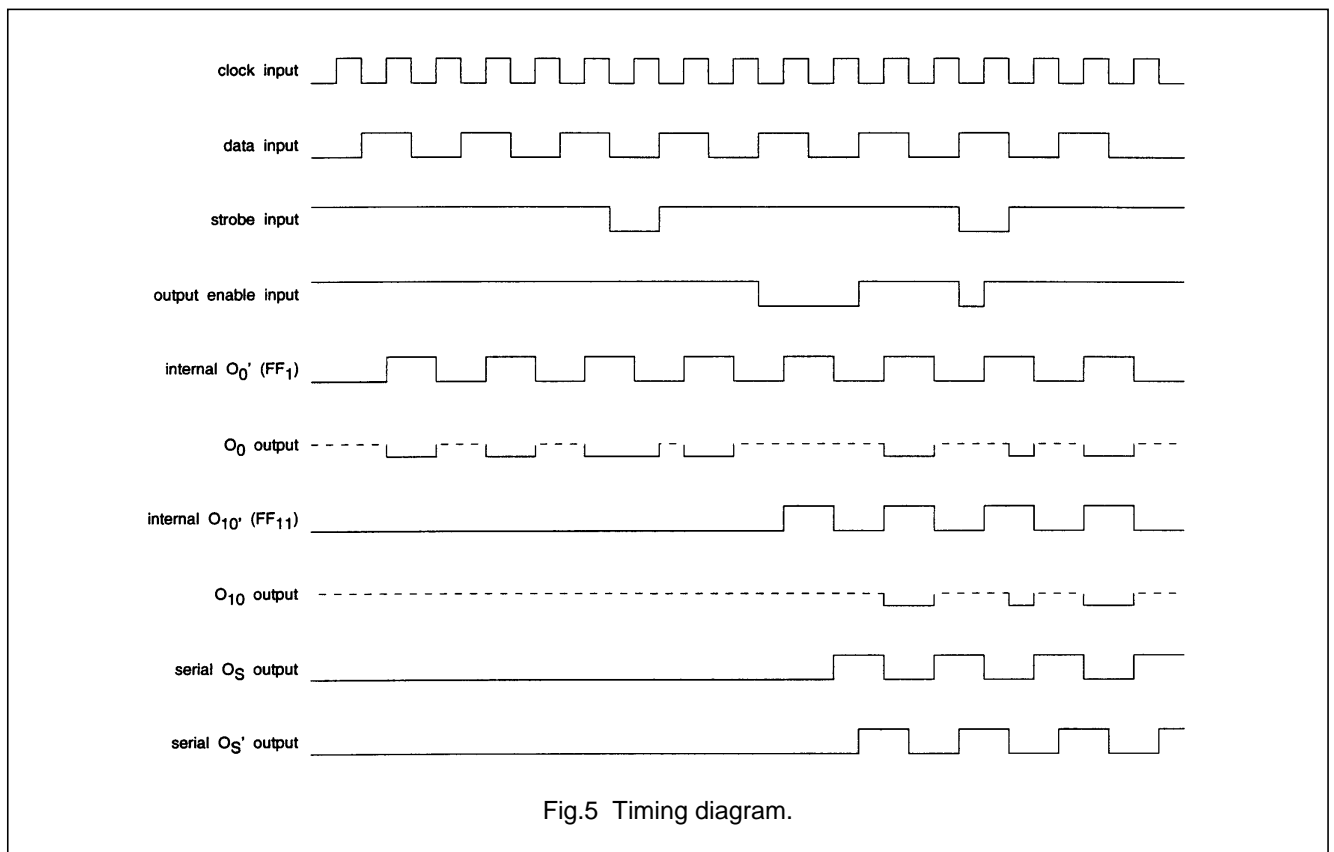

Fig.5 Timing diagram.

# 12-stage shift-and-store register LED driver

# HEF4894B

## APPLICATION INFORMATION

An example of applications for the HEF4894B is:

- Serial-to-parallel converting LED driver

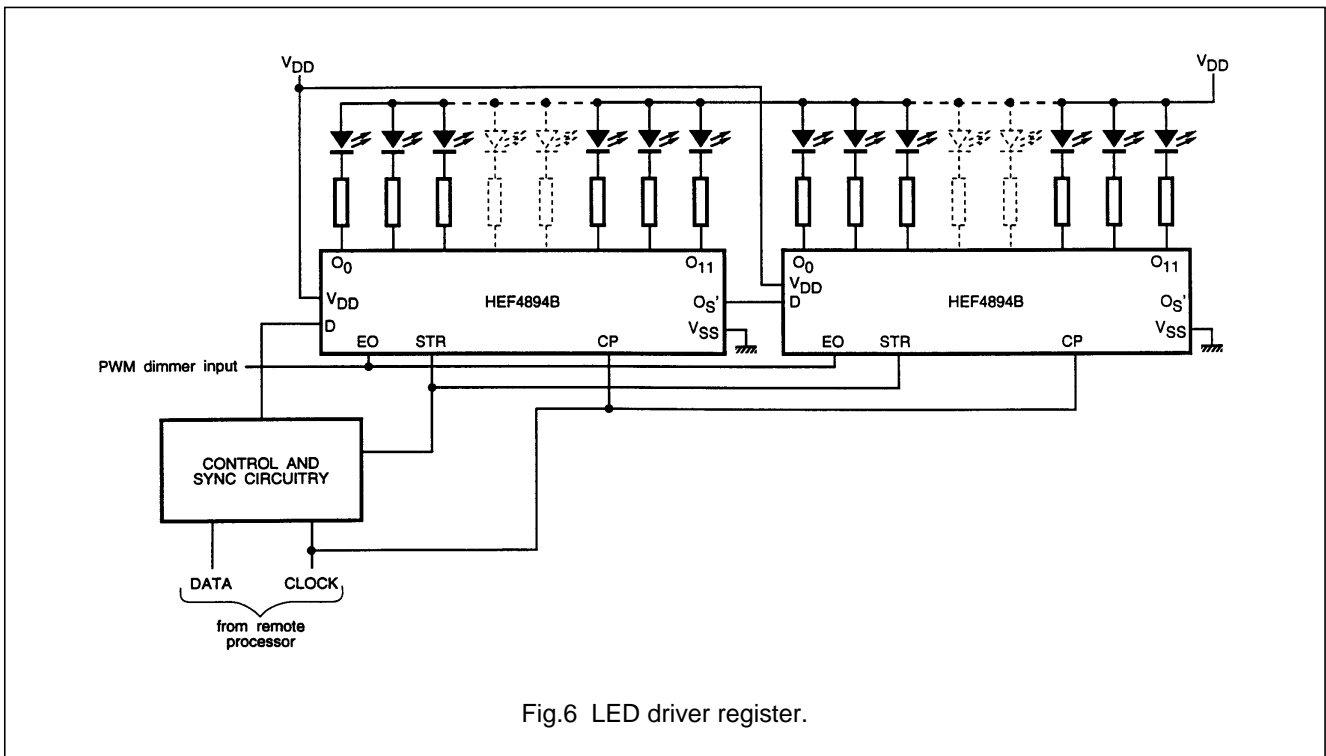

DIP20: plastic dual in-line package; 20 leads (300 mil)

SOT146-1

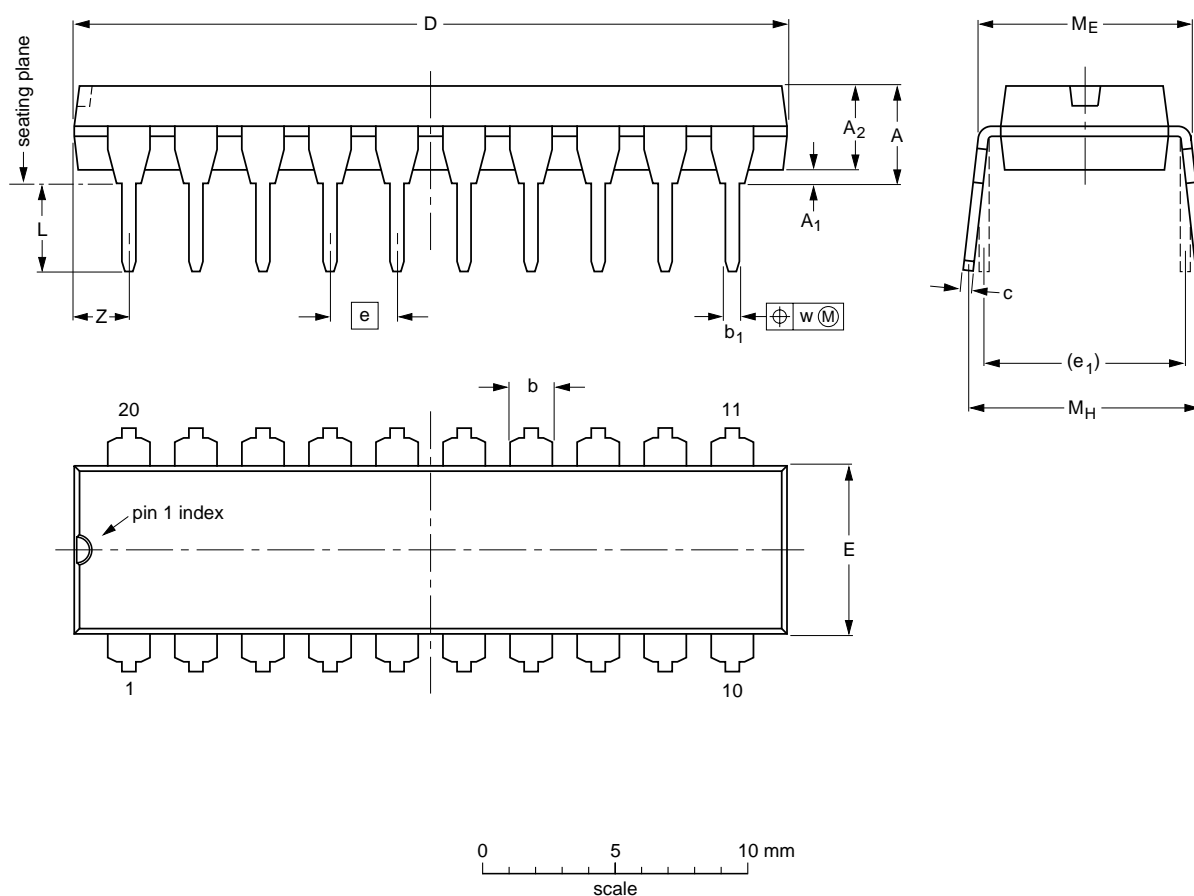

**DIMENSIONS (inch dimensions are derived from the original mm dimensions)**

UNIT	A max.	A <sub>1</sub> min.	A <sub>2</sub> max.	b	b <sub>1</sub>	c	D <sup>(1)</sup>	E <sup>(1)</sup>	e	e <sub>1</sub>	L	M <sub>E</sub>	M <sub>H</sub>	w	Z <sup>(1)</sup> max.
mm	4.2	0.51	3.2	1.73 1.30	0.53 0.38	0.36 0.23	26.92 26.54	6.40 6.22	2.54	7.62	3.60 3.05	8.25 7.80	10.0 8.3	0.254	2.0
inches	0.17	0.020	0.13	0.068 0.051	0.021 0.015	0.014 0.009	1.060 1.045	0.25 0.24	0.10	0.30	0.14 0.12	0.32 0.31	0.39 0.33	0.01	0.078

**Note**

1. Plastic or metal protrusions of 0.25 mm maximum per side are not included.

OUTLINE VERSION	REFERENCES				EUROPEAN PROJECTION	ISSUE DATE
	IEC	JEDEC	EIAJ			
SOT146-1			SC603			92-11-17 95-05-24

SO20: plastic small outline package; 20 leads; body width 7.5 mm

SOT163-1

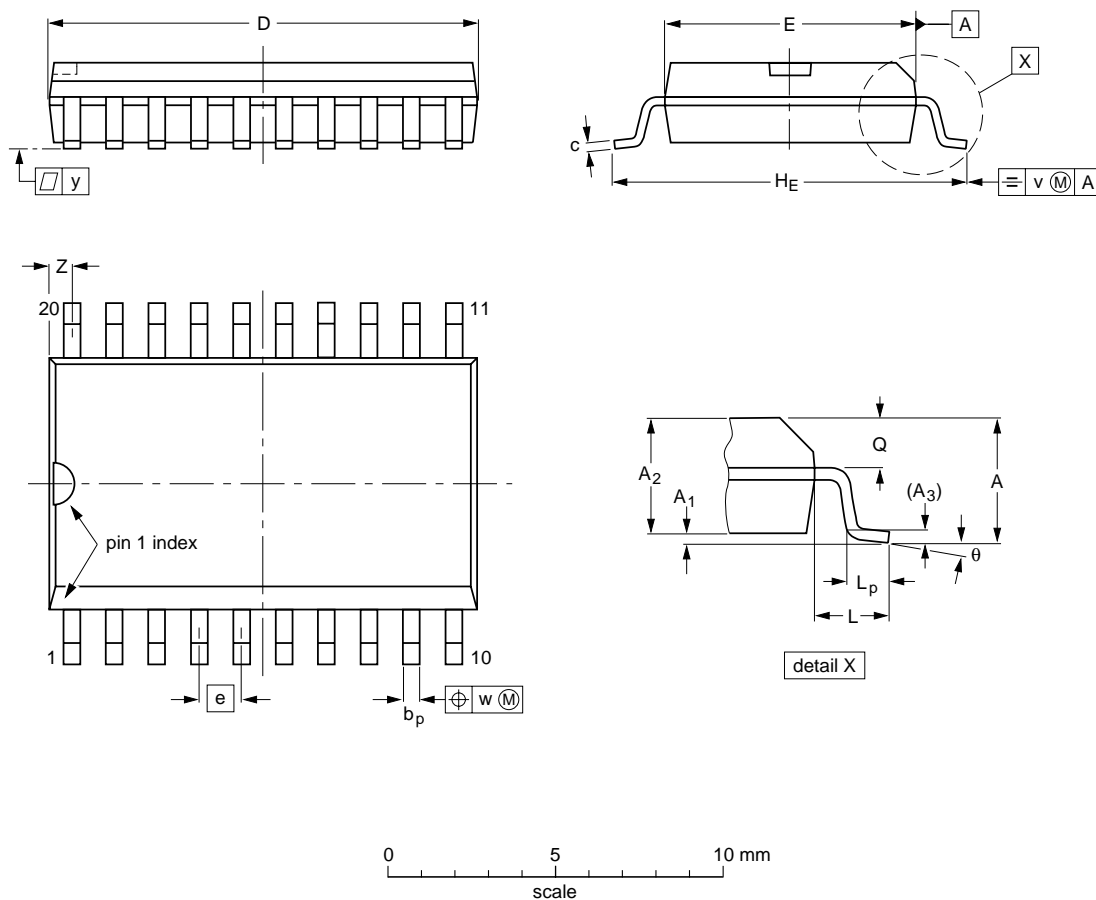

**DIMENSIONS (inch dimensions are derived from the original mm dimensions)**

UNIT	A max.	A <sub>1</sub>	A <sub>2</sub>	A <sub>3</sub>	b <sub>p</sub>	c	D <sup>(1)</sup>	E <sup>(1)</sup>	e	H <sub>E</sub>	L	L <sub>p</sub>	Q	v	w	y	z <sup>(1)</sup>	θ
mm	2.65	0.30 0.10	2.45 2.25	0.25	0.49 0.36	0.32 0.23	13.0 12.6	7.6 7.4	1.27	10.65 10.00	1.4	1.1 0.4	1.1 1.0	0.25	0.25	0.1	0.9 0.4	8° 0°
inches	0.10	0.012 0.004	0.096 0.089	0.01	0.019 0.014	0.013 0.009	0.51 0.49	0.30 0.29	0.050	0.419 0.394	0.055	0.043 0.016	0.043 0.039	0.01	0.01	0.004	0.035 0.016	

**Note**

1. Plastic or metal protrusions of 0.15 mm maximum per side are not included.

OUTLINE VERSION	REFERENCES				EUROPEAN PROJECTION	ISSUE DATE
	IEC	JEDEC	EIAJ			
SOT163-1	075E04	MS-013AC				95-01-24 97-05-22