

Datasheet

Chassis Frame Mount Panel Transformers

RS Pro

The Chassis Frame Mount Transformers 75VA to 200VA are high quality isolating transformers designed for use in general applications. The two independent secondary windings may be connected in series or parallel to give a wide range of output voltage and current options. Designed according to the following specifications.

- Low noise laminations
- Full varnish impregnation
- Fully shrouded bobbins
- Multi-hole frame fixing
- Solder tag terminations
- Optional terminal shrouds
- Detailed product specification on permanent label
- High efficiency, low regulation design
- 100% electrical and flash tested



Specifications

Power: 75 – 200 VA
 Frequency: 50 / 60 Hz
 Primary: 230 VAC
 Secondary: 2x6,2x9,2x15,2x18,2x20, 2x24,2x30,2x50
 Isolation: 4 kV RMS
 Temp class: Ta (70°) / B
 Protection cl.: IP00
 According to: EN61558-1 and EN61558-2-6 or EN61558-2-4



Schematic/connections

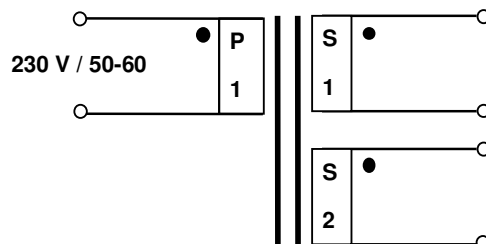

**Ordering details:**

RS Stock number	Power VA	Specification	No-load voltage	According to
504634	75	Chassis mounting Transformer, 2x6V	6.75 V	EN61558-2-6
504644	75	Chassis mounting Transformer, 2x9V	9.9 V	EN61558-2-6
504044	75	Chassis mounting Transformer, 2x12V	13.2 V	EN61558-2-6
504054	75	Chassis mounting Transformer, 2x15V	16.7 V	EN61558-2-6
504050	75	Chassis mounting Transformer, 2x18V	20.0 V	EN61558-2-6
504060	75	Chassis mounting Transformer, 2x24V	26.6 V	EN61558-2-6
504066	75	Chassis mounting Transformer, 2x50V	55.4 V	EN61558-2-4
504026	100	Chassis mounting Transformer, 2x6V	6.6 V	EN61558-2-6
504048	100	Chassis mounting Transformer, 2x9V	9.86 V	EN61558-2-6
504016	100	Chassis mounting Transformer, 2x12V	13.4 V	EN61558-2-6
504022	100	Chassis mounting Transformer, 2x15V	16.4 V	EN61558-2-6
504032	100	Chassis mounting Transformer, 2x18V	19.7 V	EN61558-2-6
504038	100	Chassis mounting Transformer, 2x20V	22.8 V	EN61558-2-6
504105	100	Chassis mounting Transformer, 2x24V	27.0 V	EN61558-2-6
504101	100	Chassis mounting Transformer, 2x30V	33.5 V	EN61558-2-6
504111	100	Chassis mounting Transformer, 2x50V	55.8 V	EN61558-2-4
504117	150	Chassis mounting Transformer, 2x6V	6.7 V	EN61558-2-6
504076	150	Chassis mounting Transformer, 2x9V	10.0 V	EN61558-2-6
504127	150	Chassis mounting Transformer, 2x12V	13.4 V	EN61558-2-6
504094	150	Chassis mounting Transformer, 2x15V	16.4 V	EN61558-2-6
504072	150	Chassis mounting Transformer, 2x18V	19.7 V	EN61558-2-6
504082	150	Chassis mounting Transformer, 2x24V	26.1 V	EN61558-2-6
504088	150	Chassis mounting Transformer, 2x50V	54.9	EN61558-2-4
504098	200	Chassis mounting Transformer, 2x6V	6.4 V	EN61558-2-6
503940	200	Chassis mounting Transformer, 2x9V	9.8 V	EN61558-2-6
503950	200	Chassis mounting Transformer, 2x12V	13.0 V	EN61558-2-6
503934	200	Chassis mounting Transformer, 2x15V	16.2 V	EN61558-2-6
503944	200	Chassis mounting Transformer, 2x18V	19.6 V	EN61558-2-6
503956	200	Chassis mounting Transformer, 2x20V	21.7 V	EN61558-2-6
503938	200	Chassis mounting Transformer, 2x24V	25.6 V	EN61558-2-6
503906	200	Chassis mounting Transformer, 2x30V	32.5 V	EN61558-2-6
503916	200	Chassis mounting Transformer, 2x50V	54.0 V	EN61558-2-4

Dimensions and fittings:

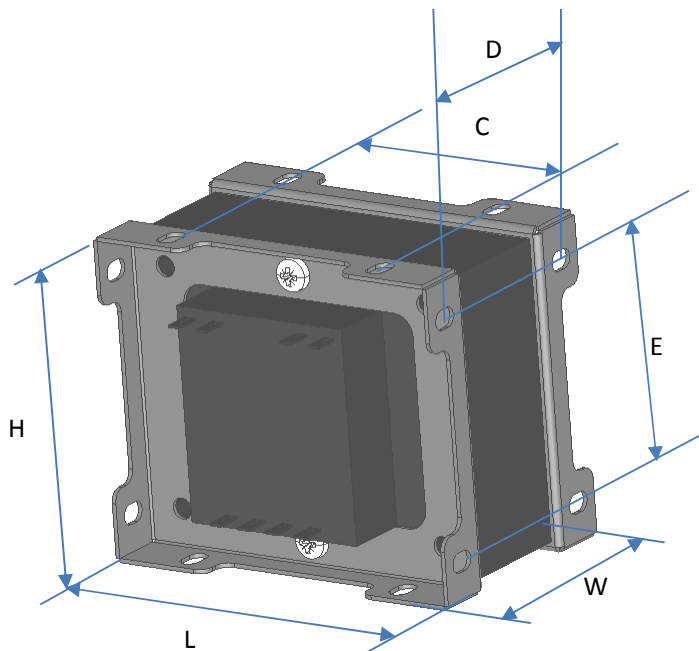

Power [VA]	Overall Size L x W x H [mm]	Fixing			Weight [kg]	Efficiency %
		Horizontal C x D [mm]	Vertical E x D (mm)	Slot size		
75	79 x 65 x 75	54 x 54	54 x 54	4.7 x 7.9	1.5	86
100	89 x 75 x 68	57 x 43.5	57 x 43.5	4.7 x 7.9	1.60	87
150	100 x 82 x 82	72 x 60	56 x 60	5.5 x 8.5	2.0	90
200	100 x 82 x 92	72 x 70	56 x 70	5.5 x 8.5	2.8	90