

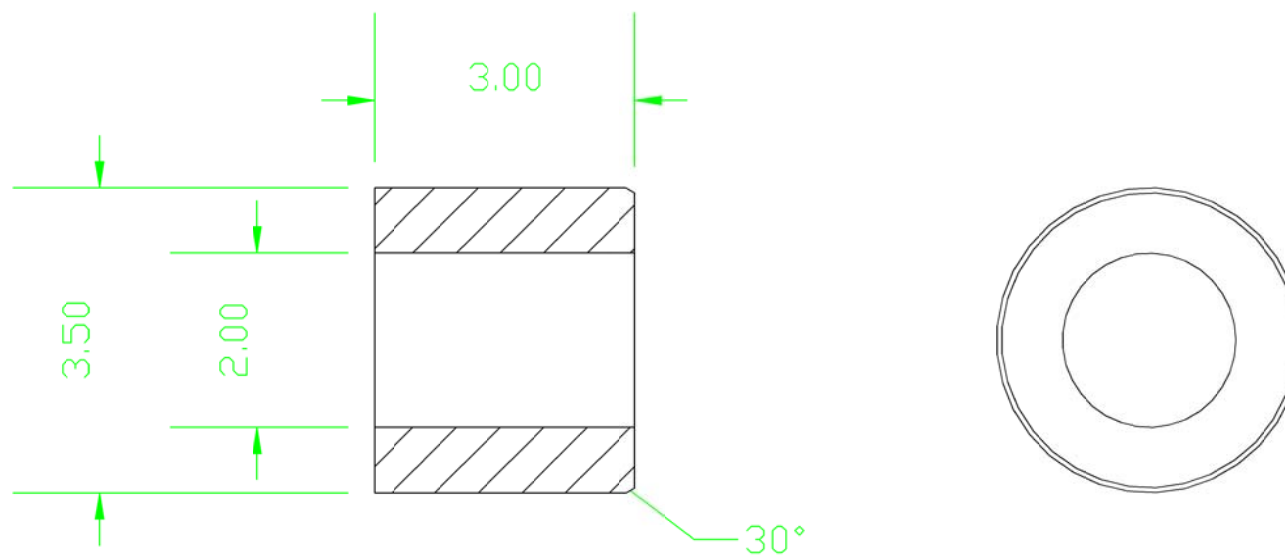

ISSUE

1

**NOTES!**

1. REMOVE ALL SHARP EDGES AND BURRS

A4

igus NO.

-

**igus**.co.uk

igus UK LTD  
51a CASWELL RD  
BRACKMILLS IND EST  
NN4 7PW  
UNITED KINGDOM ©

ALL DIMENSIONS IN mm UNLESS OTHERWISE STATED  
TOLERANCES EXCEPT WHERE OTHERWISE STATED

WHOLE NOS.	±0.4	HOLE DIAS.	+0.10
1 DEC. PL.	±0.2		-0.03
2 DEC PL.	±0.1	ANGLES	±0.5°

REFERENCE DIMENSIONS ARE NOT CRITICAL (DO NOT INSPECT)

DRN.

MATERIAL

iglidur J

TITLE

APP'D

NTL MAT'L CODE

DRG. NO.

SCALE

1:1

FINISH

JSM-0203-03



## IGLIDUR J PLAIN BEARING MATERIAL – TECHNICAL DATA SHEET

### DIN 1494 & 1850

Density	1.49 g/cm <sup>3</sup>
Colour	Yellow
Dynamic sliding coefficient of friction against steel	0.06 – 0.18
Maximum Bending Strength	73 MPa
Modulus of Elasticity (DIN 53455)	2400 MPa
Permissible mean surface static pressure @ 20°C	35 N/mm <sup>2</sup>
Shore D Hardness	74
Continuous Service Temperature	-50°C to +90°C
Maximum Service Temperature (Short term)	120°C
Thermal Conductivity (ASTM G177)	0.3 W/m . k
Linear thermal expansion coefficient (DIN 53752)	11 x 10 <sup>-5</sup>
Fire Classification UL 94 (IEC707, DIN VDE 0304 Part 3)	HB
Moisture Absorption @ RH 50/23°C	0.3 % (by weight)
Maximum Moisture Absorption	1.3 % (by weight)
Specific volume resistance (VDE 030)	10 <sup>13</sup> Ω cm
Surface Resistance (DIN 53842)	10 <sup>12</sup> Ω
Recommended Housing Bore Tolerance	H7
Recommended Shaft Tolerance	h9

The data given above is provided in good faith and is the result of laboratory tests and experience. This data should be used as a guide only, and igus is not under any obligation regarding this information. A practical test is always recommended to confirm our findings.

1) without any additional load; no sliding movement; possible relaxation of bearing press fit