



Main

Commercial Status	Commercialised
Range of product	Zelio Time
Product or component type	Industrial timing relay
Contacts type and composition	2 C/O
Component name	RE7
Time delay type	Qt
Time delay range	0.05 s...300 h
[Us] rated supply voltage	42...48 V AC/DC 50/60 Hz 24 V AC/DC 50/60 Hz 110...240 V AC 50/60 Hz

Complementary

Discrete output type	Relay
Contacts material	90/10 silver nickel contacts
Width pitch dimension	22.5 mm
Voltage range	0.85...1.1 Us
Connections - terminals	Screw terminals, clamping capacity: 2 x 2.5 mm ² flexible without cable end Screw terminals, clamping capacity: 2 x 1.5 mm ² flexible with cable end
Tightening torque	0.6...1.1 N.m
Setting accuracy of time delay	+/- 10 % of full scale
Repeat accuracy	+/- 0.2 %
Temperature drift	< 0.07 %/°C
Voltage drift	< 0.2 %/V
Minimum pulse duration	20 ms
Reset time	50 ms
Maximum switching voltage	250 V AC/DC
Mechanical durability	20000000 cycles
[Ith] conventional free air thermal current	8 A
[Ie] rated operational current	<= 0.2 A DC-13 115 V at 70 °C conforming to IEC 60947-5-1/1991/VDE 0660 <= 0.1 A DC-13 250 V at 70 °C conforming to IEC 60947-5-1/1991/VDE 0660 <= 3 A AC-15 at 70 °C conforming to IEC 60947-5-1/1991/VDE 0660 <= 2 A DC-13 24 V at 70 °C conforming to IEC 60947-5-1/1991/VDE 0660
Minimum switching capacity	12 V / 10 mA
Marking	CE
Overvoltage category	III conforming to IEC 60664-1
[Ui] rated insulation voltage	300 V between contact circuit and power supply CSA certified 300 V between contact circuit and control inputs CSA certified 250 V between contact circuit and power supply IEC certified 250 V between contact circuit and control inputs IEC certified
Supply disconnection value	> 0.1 Uc
Operating position	Any position without derating
Surge withstand	2 kV conforming to IEC 61000-4-5 level 3
Power consumption in VA	2.8 VA 110 V 12.5 VA 240 V 1.2 VA 24 V 2 VA 48 V
Power consumption in W	1.6 W 48 V 0.8 W 24 V

The information provided in this documentation contains general descriptions and/or technical characteristics of the performance of the products contained herein. This documentation is not intended as a substitute for and is not to be used for determining suitability or reliability of these products for specific user applications. It is the duty of any such user or integrator to perform the appropriate and complete risk analysis, evaluation and testing of the products with respect to the relevant specific application or use thereof. Neither Schneider Electric Industries SAS nor any of its affiliates or subsidiaries shall be responsible or liable for misuse of the information contained herein.

Terminal description	(15-16-18)OC_ON (25-26-28)OC_ON (B1-A2)CO (Z2)UNUSED ALT
Height	78 mm
Width	22.5 mm
Depth	80 mm
Product weight	0.15 kg

Environment

Immunity to microbreaks	3 ms
Standards	EN/IEC 61812-1
Product certifications	CSA GL UL
Ambient air temperature for storage	-40...85 °C
Ambient air temperature for operation	-20...60 °C
Relative humidity	15...85 % (3K3) conforming to IEC 60721-3-3
Vibration resistance	0.35 mm (f = 10...55 Hz) conforming to IEC 60068-2-6
Shock resistance	15 gn for 11 ms conforming to IEC 60068-2-27
IP degree of protection	IP50 (housing) IP20 (terminals)
Pollution degree	3 conforming to IEC 60664-1
Dielectric strength	2.5 kV
Non-dissipating shock wave	4.8 kV
Resistance to electrostatic discharge	8 kV (in air) conforming to IEC 61000-4-2 level 3 6 kV (in contact) conforming to IEC 61000-4-2 level 3
Resistance to electromagnetic fields	10 V/m conforming to IEC 61000-4-3 level 3
Resistance to fast transients	2 kV conforming to IEC 61000-4-4 level 3
Disturbance radiated/conducted	CISPR 11 group 1 - class A CISPR 22 - class A

Function Qt: Star-Delta Timing

Description

Timing for star-delta starter with double On-delay period.

Function: 1 Output

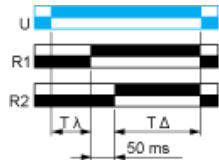

Legend

 Relay de-energised

 Relay energised

 Output open

 Output closed

C Control contact

G Gate

R Relay or solid state output

R1/ 2 timed outputs

R2

R2 The second output is instantaneous if the right position is selected inst.

T Timing period

Ta Adjustable On-delay

Tr Adjustable Off-delay

U Supply

Width 22.5 mm

Rail Mounting

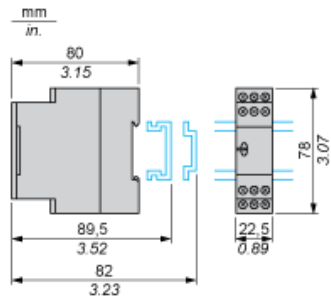

Screw Fixing

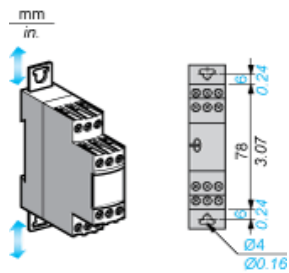

Internal Wiring Diagram



Recommended Application Wiring Diagram

Control



WARNING

UNEXPECTED EQUIPMENT OPERATION

No galvanic isolation between supply terminals A1, A2, B1, B2 and supply terminal Z2.

Failure to follow these instructions can result in death, serious injury, or equipment damage.

Star-Delta function with double On-delay timing Qt.

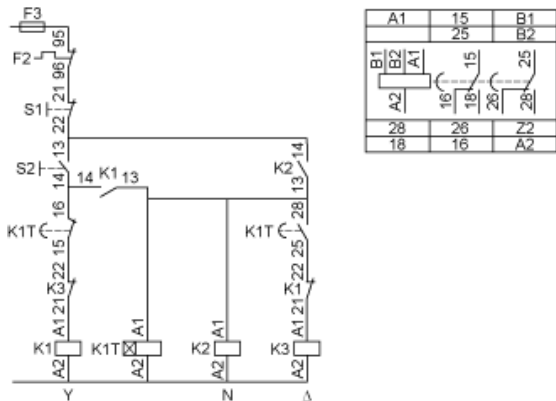

K1T Timing relay

Power

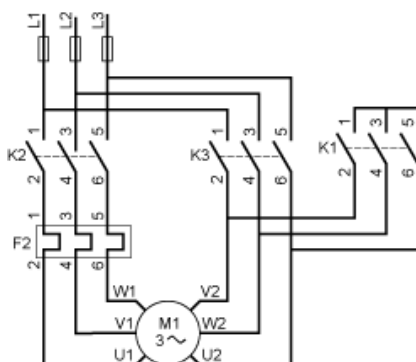

Performance Curves

A.C. Load Curve 1

Electrical durability of contacts on resistive loading millions of operating cycles

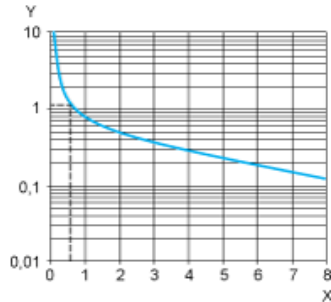

X Current broken in A
Y Millions of operating cycles

A.C. Load Curve 2

Reduction factor k for inductive loads (applies to values taken from durability curve 1).

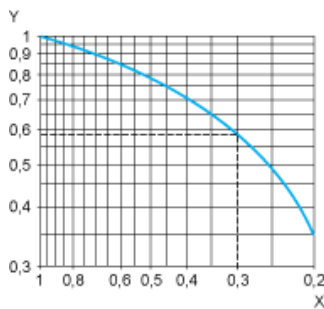

X Power factor on breaking (cos φ)
Y Reduction factor k

Example: An LC1-F185 contactor supplied with 115 V/50 Hz for a consumption of 55 VA or a current consumption equal to 0.1 A and cos φ = 0.3. For 0.1 A, curve 1 indicates a durability of approximately 1.5 million operating cycles. As the load is inductive, it is necessary to apply a reduction coefficient k to this number of cycles as indicated by curve 2. For cos φ = 0.3: k = 0.6 The electrical durability therefore becomes: 1.5 10⁶ operating cycles x 0.6 = 900 000 operating cycles.

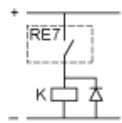

D. C. Load Limit Curve

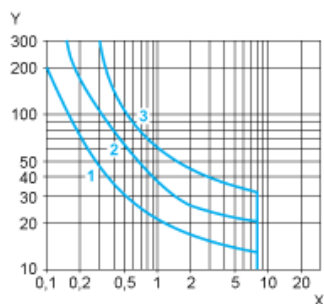

X Current in A
Y Voltage in V
1 L/R = 20 ms
2 L/R with load protection diode
3 Resistive load