

TC74HC42AP, TC74HC42AF, TC74HC42AFN

BCD to Decimal Decoder

The TC74HC42A is a high speed CMOS BCD-to-DECIMAL DECODER fabricated with silicon gate C²MOS technology.

It achieves the high speed operation similar to equivalent LSTTL while maintaining the CMOS low power dissipation.

A BCD code applied to the four inputs (A-D) sets a low level at one of ten decoded outputs. A illegal BCD code such as eleven thru fifteen sets all outputs high. This device can be used as 3-to-8 LINE DECODER when input D is held low.

This device is useful for code conversion, address decoding, memory selection, multiplexing, or readout decoding.

All inputs are equipped with protection circuits against static discharge or transient excess voltage.

Features

- High speed: $t_{pd} = 13 \text{ ns (typ.)}$ at $V_{CC} = 5 \text{ V}$
- Low power dissipation: $I_{CC} = 4 \mu\text{A (max)}$ at $T_a = 25^\circ\text{C}$
- High noise immunity: $V_{NIH} = V_{NIL} = 28\% V_{CC} \text{ (min)}$
- Output drive capability: 10 LSTTL loads
- Symmetrical output impedance: $|I_{OH}| = I_{OL} = 4 \text{ mA (min)}$
- Balanced propagation delays: $t_{pLH} \approx t_{pHL}$
- Wide operating voltage range: $V_{CC} \text{ (opr)} = 2\sim 6 \text{ V}$
- Pin and function compatible with 74LS42

Pin Assignment

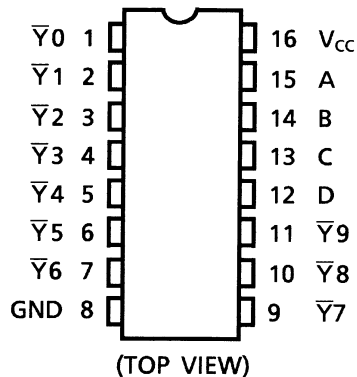

Note: xxxFN (JEDEC SOP) is not available in Japan.

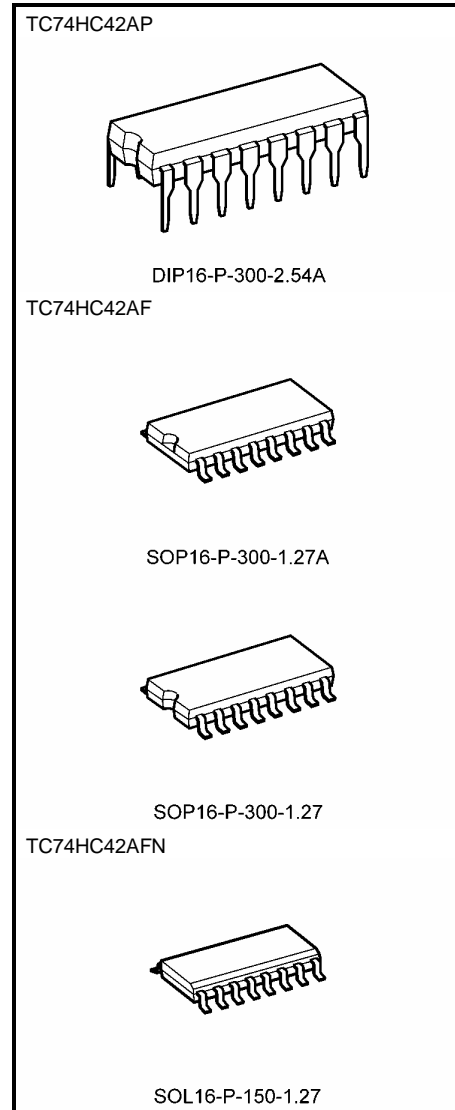

Weight	
DIP16-P-300-2.54A	: 1.00 g (typ.)
SOP16-P-300-1.27A	: 0.18 g (typ.)
SOP16-P-300-1.27	: 0.18 g (typ.)
SOL16-P-150-1.27	: 0.13 g (typ.)

IEC Logic Symbol

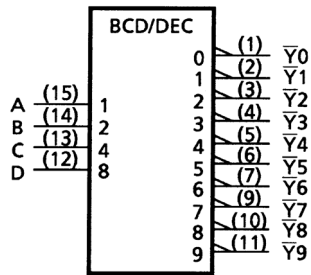

Truth Table

Code No.	BCD Inputs				Decimal Outputs									
	D	C	B	A	\bar{Y}_0	\bar{Y}_1	\bar{Y}_2	\bar{Y}_3	\bar{Y}_4	\bar{Y}_5	\bar{Y}_6	\bar{Y}_7	\bar{Y}_8	\bar{Y}_9
0	L	L	L	L	L	H	H	H	H	H	H	H	H	H
1	L	L	L	H	H	L	H	H	H	H	H	H	H	H
2	L	L	H	L	H	H	L	H	H	H	H	H	H	H
3	L	L	H	H	H	H	H	L	H	H	H	H	H	H
4	L	H	L	L	H	H	H	H	L	H	H	H	H	H
5	L	H	L	H	H	H	H	H	H	L	H	H	H	H
6	L	H	H	L	H	H	H	H	H	H	L	H	H	H
7	L	H	H	H	H	H	H	H	H	H	H	L	H	H
8	H	L	L	L	H	H	H	H	H	H	H	H	L	H
9	H	L	L	H	H	H	H	H	H	H	H	H	H	L
—	H	X	H	X	H	H	H	H	H	H	H	H	H	H
—	H	H	X	X	H	H	H	H	H	H	H	H	H	H

X: Don't care

System Diagram

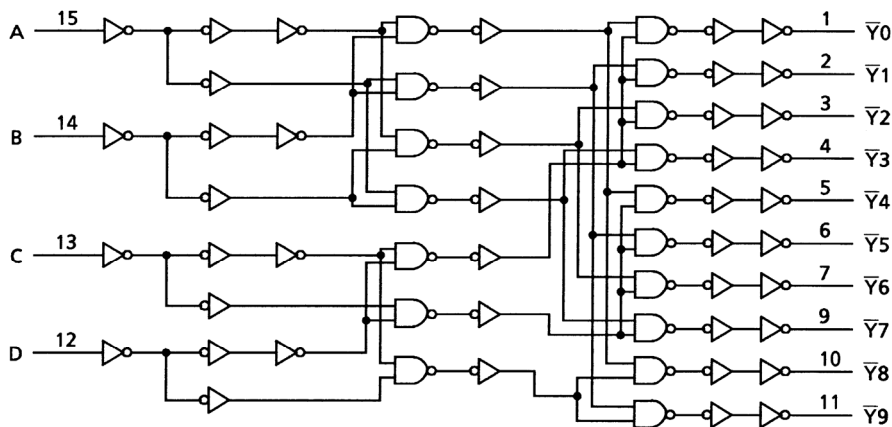

Absolute Maximum Ratings (Note 1)

Characteristics	Symbol	Rating	Unit
Supply voltage range	V_{CC}	-0.5~7	V
DC input voltage	V_{IN}	-0.5~ $V_{CC} + 0.5$	V
DC output voltage	V_{OUT}	-0.5~ $V_{CC} + 0.5$	V
Input diode current	I_{IK}	± 20	mA
Output diode current	I_{OK}	± 20	mA
DC output current	I_{OUT}	± 25	mA
DC V_{CC} /ground current	I_{CC}	± 50	mA
Power dissipation	P_D	500 (DIP) (Note 2)/180 (SOP)	mW
Storage temperature	T_{stg}	-65~150	°C

Note 1: Exceeding any of the absolute maximum ratings, even briefly, lead to deterioration in IC performance or even destruction.

Note 2: 500 mW in the range of $T_a = -40$ to 65°C . From $T_a = 65$ to 85°C a derating factor of -10 mW/°C shall be applied until 300 mW.

Recommended Operating Conditions (Note)

Characteristics	Symbol	Rating	Unit
Supply voltage	V_{CC}	2~6	V
Input voltage	V_{IN}	0~ V_{CC}	V
Output voltage	V_{OUT}	0~ V_{CC}	V
Operating temperature	T_{opr}	-40~85	°C
Input rise and fall time	t_r, t_f	0~1000 ($V_{CC} = 2.0$ V) 0~500 ($V_{CC} = 4.5$ V) 0~400 ($V_{CC} = 6.0$ V)	ns

Note: The recommended operating conditions are required to ensure the normal operation of the device. Unused inputs must be tied to either VCC or GND.

Electrical Characteristics

DC Characteristics

Characteristics	Symbol	Test Condition		Ta = 25°C			Ta = -40~85°C		Unit	
				V _{CC} (V)	Min	Typ.	Max	Min		Max
High-level input voltage	V _{IH}	—		2.0	1.50	—	—	1.50	—	V
				4.5	3.15	—	—	3.15	—	
				6.0	4.20	—	—	4.20	—	
Low-level input voltage	V _{IL}	—		2.0	—	—	0.50	—	0.50	V
				4.5	—	—	1.35	—	1.35	
				6.0	—	—	1.80	—	1.80	
High-level output voltage	V _{OH}	V _{IN} = V _{IH} or V _{IL}	I _{OH} = -20 μA	2.0	1.9	2.0	—	1.9	—	V
				4.5	4.4	4.5	—	4.4	—	
			I _{OH} = -4 mA	4.5	4.18	4.31	—	4.13	—	
			I _{OH} = -5.2 mA	6.0	5.68	5.80	—	5.63	—	
Low-level output voltage	V _{OL}	V _{IN} = V _{IH} or V _{IL}	I _{OL} = 20 μA	2.0	—	0.0	0.1	—	0.1	V
				4.5	—	0.0	0.1	—	0.1	
			I _{OL} = 4 mA	4.5	—	0.17	0.26	—	0.33	
			I _{OL} = 5.2 mA	6.0	—	0.18	0.26	—	0.33	
Input leakage current	I _{IN}	V _{IN} = V _{CC} or GND		6.0	—	—	±0.1	—	±1.0	μA
Quiescent supply current	I _{CC}	V _{IN} = V _{CC} or GND		6.0	—	—	4.0	—	40.0	μA

AC Characteristics (C_L = 15 pF, V_{CC} = 5 V, Ta = 25°C, input: t_r = t_f = 6 ns)

Characteristics	Symbol	Test Condition	Min	Typ.	Max	Unit
Output transition time	t _{TLH}	—	—	4	8	ns
	t _{THL}					
Propagation delay time	t _{pLH}	—	—	13	25	ns
	t _{pHL}					

AC Characteristics ($C_L = 50 \text{ pF}$, input: $t_r = t_f = 6 \text{ ns}$)

Characteristics	Symbol	Test Condition	V_{CC} (V)	$T_a = 25^\circ\text{C}$			$T_a = -40\sim 85^\circ\text{C}$		Unit
				Min	Typ.	Max	Min	Max	
Output transition time	t_{TLH}	—	2.0	—	30	75	—	95	ns
	t_{THL}		4.5	—	8	15	—	19	
			6.0	—	7	13	—	16	
Propagation delay time	t_{pLH}	—	2.0	—	48	145	—	180	ns
	t_{pHL}		4.5	—	16	29	—	36	
			6.0	—	14	25	—	31	
Input capacitance	C_{IN}	—	—	5	10	—	10	pF	
Power dissipation capacitance	C_{PD} (Note)	—	—	68	—	—	—	pF	

Note: C_{PD} is defined as the value of the internal equivalent capacitance which is calculated from the operating current consumption without load.

Average operating current can be obtained by the equation:

$$I_{CC}(\text{opr}) = C_{PD} \cdot V_{CC} \cdot f_{IN} + I_{CC}$$

Package Dimensions

DIP16-P-300-2.54A

Unit : mm

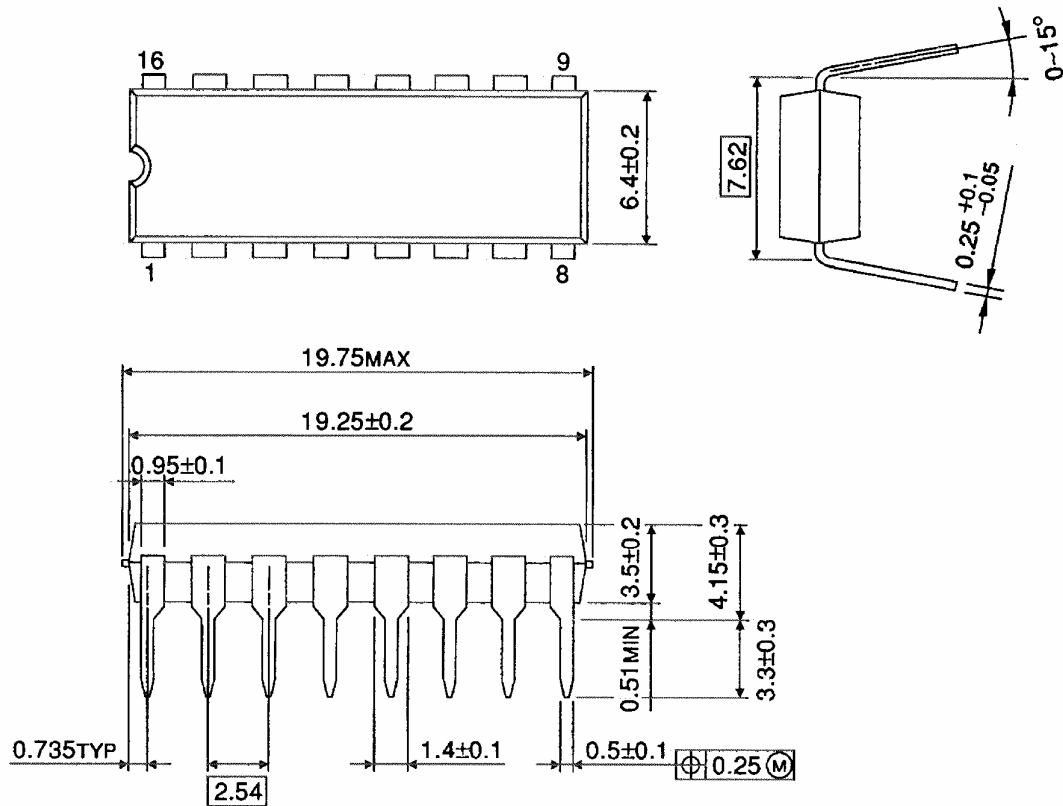

Weight: 1.00 g (typ.)

Package Dimensions

SOP16-P-300-1.27A

Unit: mm

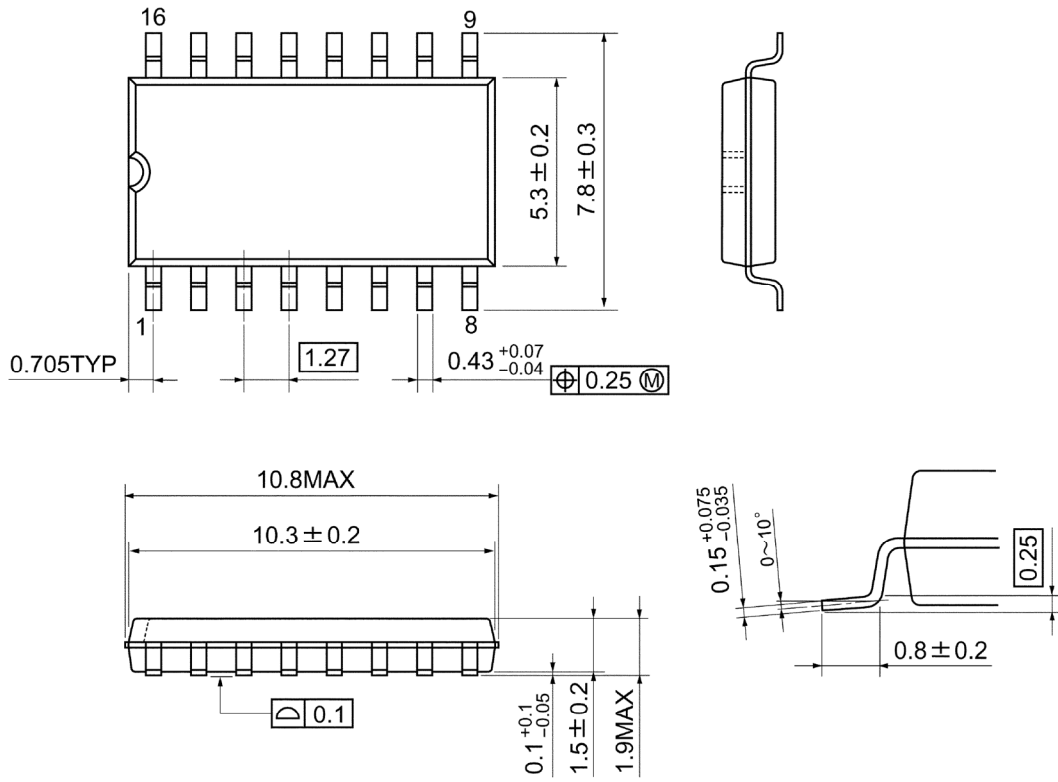

Weight: 0.18 g (typ.)

Package Dimensions

SOP16-P-300-1.27

Unit : mm

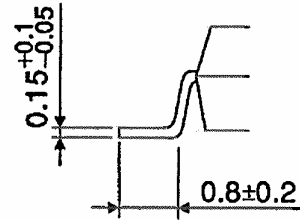
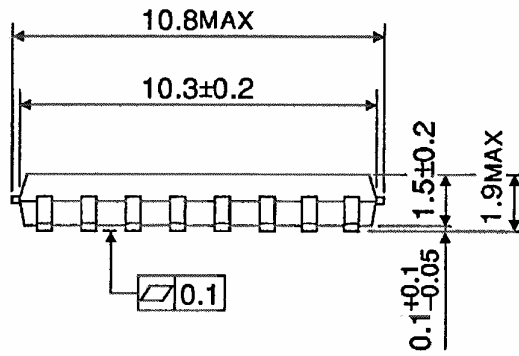
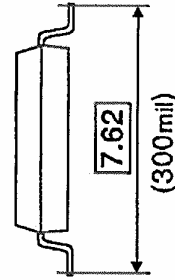
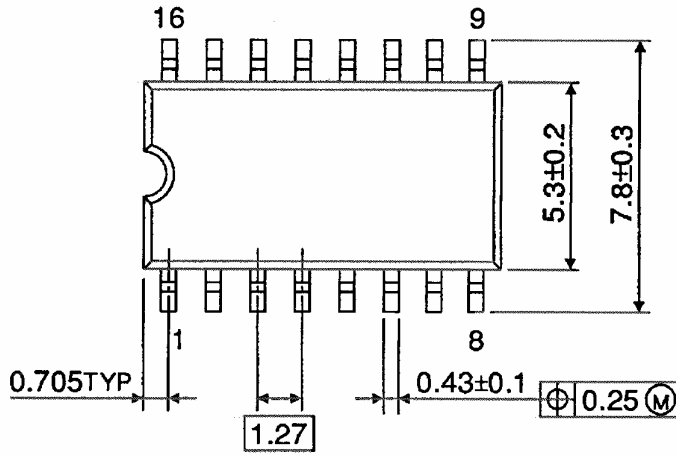

Weight: 0.18 g (typ.)

Package Dimensions (Note)

SOL16-P-150-1.27

Unit : mm

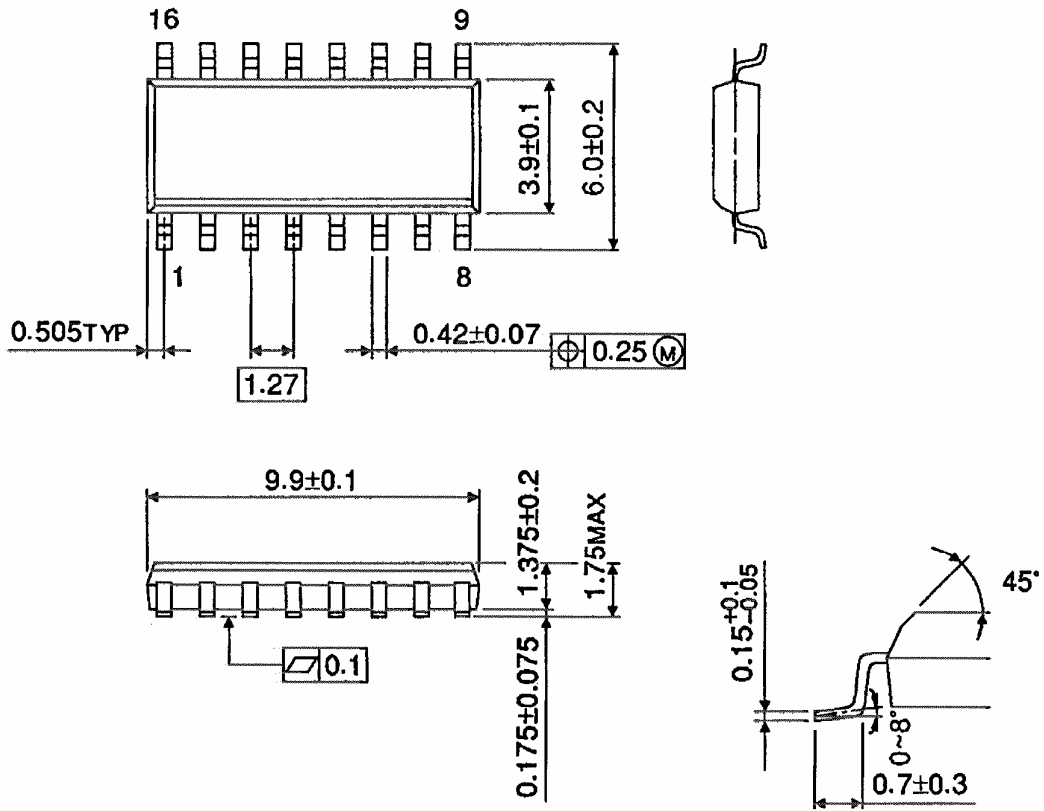

Note: This package is not available in Japan.

Weight: 0.13 g (typ.)

Note: Lead (Pb)-Free Packages**DIP14-P-300-2.54 SOP14-P-300-1.27A SOL14-P-150-1.27****RESTRICTIONS ON PRODUCT USE**

060116EBA

- The information contained herein is subject to change without notice. 021023_D
- TOSHIBA is continually working to improve the quality and reliability of its products. Nevertheless, semiconductor devices in general can malfunction or fail due to their inherent electrical sensitivity and vulnerability to physical stress. It is the responsibility of the buyer, when utilizing TOSHIBA products, to comply with the standards of safety in making a safe design for the entire system, and to avoid situations in which a malfunction or failure of such TOSHIBA products could cause loss of human life, bodily injury or damage to property.
In developing your designs, please ensure that TOSHIBA products are used within specified operating ranges as set forth in the most recent TOSHIBA products specifications. Also, please keep in mind the precautions and conditions set forth in the "Handling Guide for Semiconductor Devices," or "TOSHIBA Semiconductor Reliability Handbook" etc. 021023_A
- The TOSHIBA products listed in this document are intended for usage in general electronics applications (computer, personal equipment, office equipment, measuring equipment, industrial robotics, domestic appliances, etc.). These TOSHIBA products are neither intended nor warranted for usage in equipment that requires extraordinarily high quality and/or reliability or a malfunction or failure of which may cause loss of human life or bodily injury ("Unintended Usage"). Unintended Usage include atomic energy control instruments, airplane or spaceship instruments, transportation instruments, traffic signal instruments, combustion control instruments, medical instruments, all types of safety devices, etc. Unintended Usage of TOSHIBA products listed in this document shall be made at the customer's own risk. 021023_B
- The products described in this document shall not be used or embedded to any downstream products of which manufacture, use and/or sale are prohibited under any applicable laws and regulations. 060106_Q
- The information contained herein is presented only as a guide for the applications of our products. No responsibility is assumed by TOSHIBA for any infringements of patents or other rights of the third parties which may result from its use. No license is granted by implication or otherwise under any patent or patent rights of TOSHIBA or others. 021023_C
- The products described in this document are subject to the foreign exchange and foreign trade laws. 021023_E