

XL2

OPERATING MANUAL
HANDHELD AUDIO AND
ACOUSTIC ANALYZER

Contact Details

NTi Audio AG
Im alten Riet 102
9494 Schaan
Liechtenstein, Europe

Tel.: +423 239 6060
Fax: +423 239 6089
E-Mail: info@nti-audio.com

NTI Americas
PO Box 231027
Tigard, Oregon 97281
USA

Tel.: +1 503 684 7050
Fax: +1 503 684 7051
E-Mail: americas@nti-audio.com

NTI China
Room 722, 7F, Building 6-3A,
No 1388, Bin He Rd.
215000 Suzhou, China

Tel.: +86 512 6802 0075
Fax: +86 512 6802 0097
E-Mail: china@nti-audio.com

NTI Japan
Ryogokusakamoto Bld. 1-8-4
Ryogoku, 130-0026 Sumida-Ku
Tokyo, Japan

Tel.: +81 3 3634 6110
Fax: +81 3 3634 6160
E-Mail: japan@nti-audio.com

Firmware V1.10
Version 1.10.3 / Jan. 2010

All information subject to change without notice.

© All rights reserved.

® Minirator is an registered trademark of NTi Audio.

™ XL2, EXEL, M4260, M2210, MR-PRO, MR2 and TalkBox are trademarks of NTi Audio.

Table of Contents

1. Introduction	4	6. Audio Analyzer	93
2. Overview of the Instrument	6	RMS / THD	93
Power Supply	12	Scope	95
Attaching the Hand Strap	15	7. Calibration	96
Unfold the Stand	16	8. Documentation of Test Results	98
Connecting the XL2	16	9. Microphones	101
3. Basic Operation	18	10. Further Information	103
Switching the XL2 On and Off	18	Tips and Trouble Shooting	103
Instrument Settings	18	Firmware Update of XL2.....	104
System Settings	20	Options	105
4. Sound Level Meter	24	Accessories	106
Overview	27	Warranty Conditions	108
Logging	37	Declaration of Conformity.....	109
Reporting	39	Information for Disposal and Recycling	109
Wave File Recording	40	11. Technical Data XL2	110
Voice Notes.....	41	12. Technical Data Microphones	113
Limit LED Indication.....	42	Appendix	114
Sound Level Meter - Getting Started	43	Appendix 1: Standard - Extended Features.....	114
RTA Measurement - Getting Started	49	Appendix 2: Application Profiles	116
5. Acoustical Analyzer	54	Appendix 3: Description Sound Levels	120
FFT Analysis.....	54	Appendix 4: Common Sound Levels.....	123
Reverberation Time RT60.....	60		
Polarity	72		
Delay Time	76		
Speech Intelligibility STI-PA (optional)	82		









1. Introduction

Thank you for purchasing the XL2 Audio and Acoustic Analyzer. The XL2 forms the combination of a state-of-the-art acoustical analyzer and a powerful audio analyzer tailored for Sound Installations, Live Sound, Recording Studios, Broadcast, Environmental Noise Measurements and Service.

The XL2 is equipped with the following functions:

- Sound Level Meter
- Real Time Analyzer
- Acoustic Analyzer
- STI-PA Analyzer
- Audio Analyzer
- Wave File Recording
- Voice Notes for logged measurements
- Mini-SD Card, removable
- Built-in Real Time Clock
- Automated Sensor Detection
- Rechargeable Power Supply Li-Po Battery
- Optional: Serial programmable I/O Interface

How to Read this Manual

The XL2 push buttons are displayed as icons , , , , , , , , . The detailed description of the push buttons is listed in the chapter “Buttons and operating elements.”

Menu items displayed on the XL2 page are indicated by a bold font, e.g. **SLMeter**, **Parameter**, ...

Product Configurations

The following items are included with the respective model:

XL2 + M4260:

- XL2 Analyzer
- M4260 Microphone packed in protection pouch
- Wind protection
- Mic-holder + Adapter 5/8" - 3/8"
- Test Signal CD
- Li-Po battery
- USB cable
- Hand strap
- Operating manual

XL2 + M2210:

- XL2 Analyzer
- M2210 Microphone packed in protection pouch
- Wind protection
- Mic-holder + Adapter 5/8" - 3/8"
- Test Signal CD
- Li-Po battery
- USB cable
- Hand strap
- Operating manual

XL2 without
Microphone:

- XL2 Analyzer
- Test Signal CD
- USB cable
- Li-Po battery
- Hand strap
- Operating manual

2. Overview of the Instrument

The XL2 offers the following interfaces:

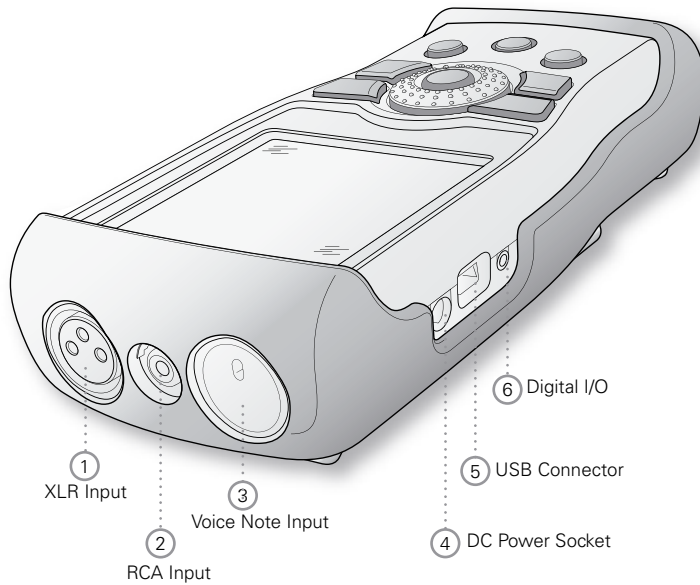

① XLR Signal Input

Balanced audio signal input as well the measurement microphone M4260 or M2210 plugs directly into the XLR input. The XLR input supports the automated sensor detection ASD and provides 48V phantom power supply for the measurement microphones M4260 and M2210.

② RCA Input

Unbalanced audio signal input.

③ VoiceNote Input

Internal microphone for recording voice notes, measuring polarity and delay time. For polarity measurements an external microphone such as the M4260 or M2210 may also be used.

④ DC Power Socket

Socket for mains power adapter. Read more in the chapter “Power Supply” in this manual.

⑤ USB Connector

Mini-B USB connection, for accessing the Mini-SD card.

⑥ Digital I/O

Programmable serial inputs/outputs. For future use; not active at this time.

⑦ Mini-SD Card

For storing ASCII data, screen shots, voice notes and WAV-files and for firmware updates.

⑧ TOSLink Output

24 bit linear PCM audio signal output. For future use; not active at this time.

⑨ Headphone Output

The XLR/RCA input signal is connected to the headphone output. Connecting a headphone disables the speaker ⑩ automatically.

In case the headphone output is connected to a line input, then a load impedance lower than 8 kOhm is required to enable the operation. Thus e.g. install a 1 kOhm resistance between tip and ground in the line connection.

⑩ Speaker

The XLR/RCA input signal is connected to the speaker. Pressing the speaker button  switches the speaker on/off and supports the volume control.

⑪ Tripod Mount

Mechanical mount for fixing the XL2 on a tripod.

Buttons and Operating Elements

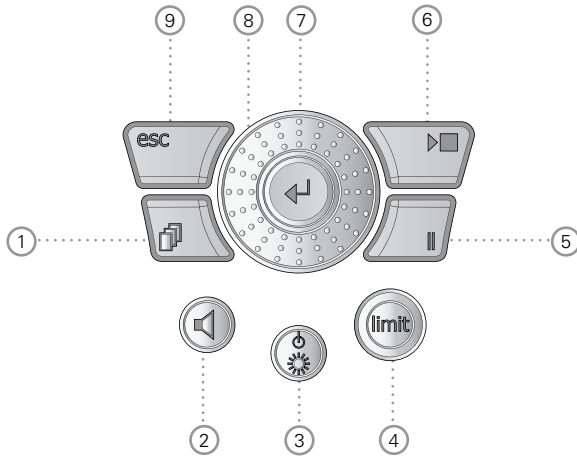

① Page Control

Switches between available display result screens within the same function menu.

② Volume of Speaker and Headphone Output

- Press the button shortly to enable the speaker.
- Press and hold down the speaker button .

The pop-up window volume is displayed.

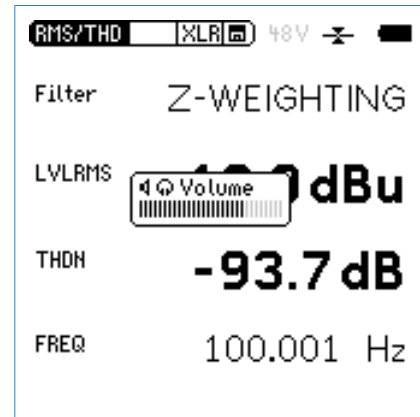

- Keep the speaker button pressed and adjust the volume of speaker and headphone output with the rotary wheel .
- Press the button shortly to mute the speaker.



③ Power & Backlight

The power button switches the instrument on. Then if held down for one second it switches the XL2 off. Additionally a short press on the power  switches the backlight on and off during operation.

④ Limit

The button lights up in green, yellow or red colors based on the application profiles according to DIN 15905 or SLV 2007.

⑤ Pause

Pauses the measurement. The measurement continues upon pressing the pause button  or the start/stop button .

⑥ Start/Stop

Starts and stops the measurement.

⑦ Enter

Confirms a selection.

⑧ Rotary Wheel

Selecting the required measurement function or the individual measurement parameter.

⑨ ESC

Terminates an entry, jumps to the top menu level or closes an open window.

The Screen Display

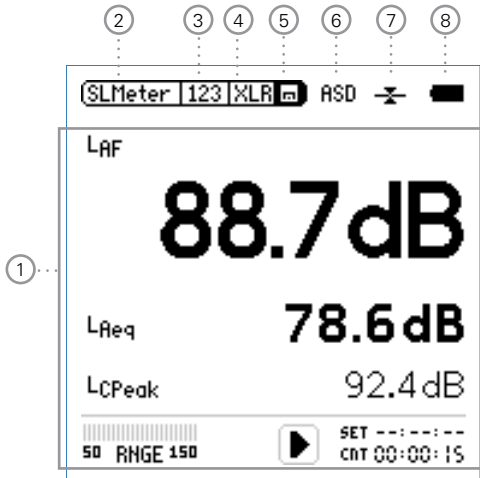

① Measurement Results

Individual measurement result display based on the selected measurement function.

② Main Menu

SLMeter	SPL & RTA Measurement
FFT	FFT Analysis
RT60	Reverberation Time RT60
Polarity	Polarity
Delay	Delay Time
RMS/THD	RMS Level and Distortion
Scope	Scope
STI-PA	Speech Intelligibility
Calibrte	Calibration Menu for microphone sensitivity
System	System Settings

③ Page Selector

Toggles between available measurement- and result pages within the same function menu. Alternatively you may use the page button .

④ Input Selector

Select input connector XLR or RCA.

5 Store

Generates measurement reports, records a voice note or stores screenshots.

6 Phantom Power

The XL2 generates 48 VDC phantom power for the measurement microphones M4260 or M2210. The enabled phantom power is displayed by **48 V**. Upon connecting the measurement microphone M4260 or M2210, the automated sensor detection reads the electronic data sheet and the display changes from **48 V** to **ASD**.

7 Balance Indicator

Indication of the audio signal balance between pin 2 and 3 on the XLR input for input signals > -40 dBu.



The input signal is balanced.



The signal is unbalanced. The level of pin 2 is higher than at pin 3.



The signal is unbalanced. The level of pin 3 is higher than at pin 2.

8 Battery Symbol

The battery symbol indicates the battery status as follows:

Using rechargeable Li-Po battery:



The battery is full.



The battery is almost empty and must be recharged.



The battery is recharged presently by the mains power adapter or the USB connection to PC.

Using standard AA batteries:

No indication of full or half full batteries.



The batteries are almost empty and must be replaced.

Using mains power supply:

No indication of battery status.

3. Getting Started

Power Supply

The XL2 offers a flexible power management and can be operated either by

- Mains power supply
- Replaceable, rechargeable lithium-polymer (Li-Po) battery
- 4x AA-batteries

The Li-Po battery is included with the XL2 Analyzer. The new battery is charged by approximately 50%; thus charge the Li-Po battery first by

Battery Charger (optional)	Charging Time: approx. 3 hours NTi Audio #: 600 000 332
Mains Power Adapter (optional)	Charging Time: approx. 6 hours Leave the battery inside and switch the XL2 off for charging. NTi Audio #: 600 000 333
USB connection to PC	Charging Time: approx. 6 hours XL2 switches to the mass storage device mode for download of data. Switch the XL2 off for faster charging.

Operation using Mains Power Supply

You can also operate the XL2 with mains power by the NTi Audio DC power supply unit. During operation with the external mains power adapter, the batteries are recommended to remain inside the instrument.

	<p>Non-original power supplies may interfere with the measurement.</p>
	<p>Power supply details:</p> <ul style="list-style-type: none"> • Electrically-isolated, switching or linear DC power supply • Voltage: 7.5 - 9 Volt • Current: min. 800 mA • Connector type: 2.1 x 5.5 x 9.5 mm • Polarity: + -.
	<p>A decreased THD+N performance will occur at unbalanced input signals by using switching type power supplies (approx. 3 dB).</p> <p>Damage caused by using an inappropriate external DC supply is not covered by warranty.</p>

Rechargeable Li-Po Battery

- Open the battery cover at the upper flap.
- Insert the rechargeable Li-Po battery with the contacts edge first.
- Close the battery cover.



Switch the XL2 off for faster recharging by mains power adapter or USB connection.



Caution

- Avoid short circuits.
- Operate and charge the battery between 0°C and 45°C (32°F - 113°F).
- Do not heat the battery above 60°C.
- Do not dispose of the battery by burning.
- Do not solder directly to the battery.
- Do not disassemble the battery.
- Do not insert the battery in reverse polarity.
- The Li-Po battery has a potential for fire or burning.

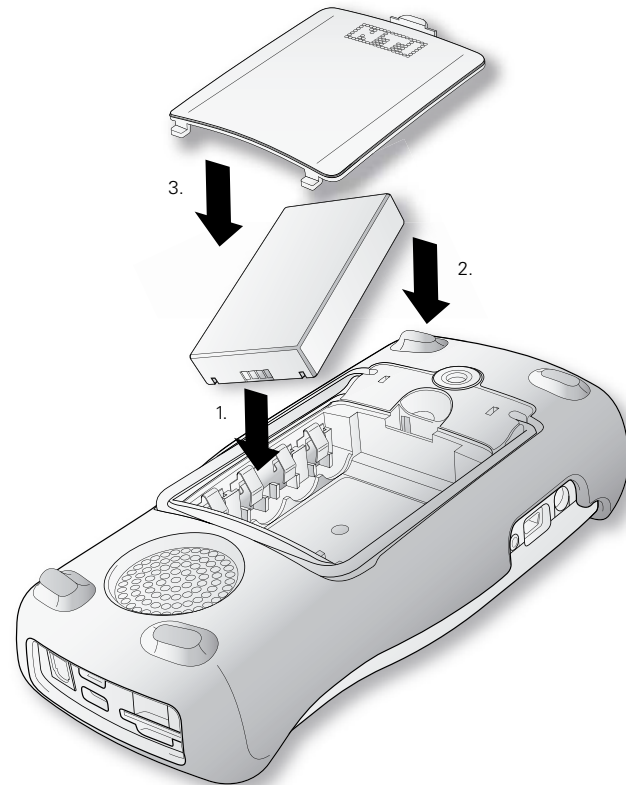

AA-Batteries

Alternatively the XL2 also runs with AA batteries.

- Open the battery cover.
- Insert 4x AA batteries with the same state of charge, paying attention to the +/- marking in the battery compartment.
- Close the battery cover.



- Only use batteries from the same manufacturer.
- Replace the discharged batteries by new ones.
- Do not mix used and new batteries.
- During operation, the battery temperature may increase noticeably. This is not a defect.



Remove the batteries if the XL2 is not used for longer time.

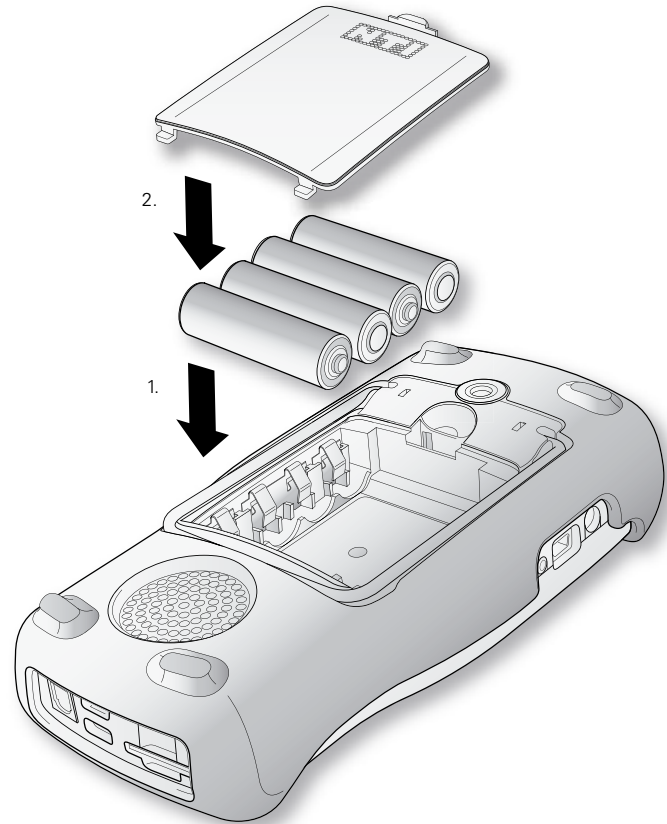

Attaching the Hand Strap

To ensure the XL2 is kept safely in your hands, a hand strap is supplied with the instrument.

- Pull the hand strap through the opening.
- Pull the rear part of the hand strap through the loop of the front part.
- Pull the hand strap tight.

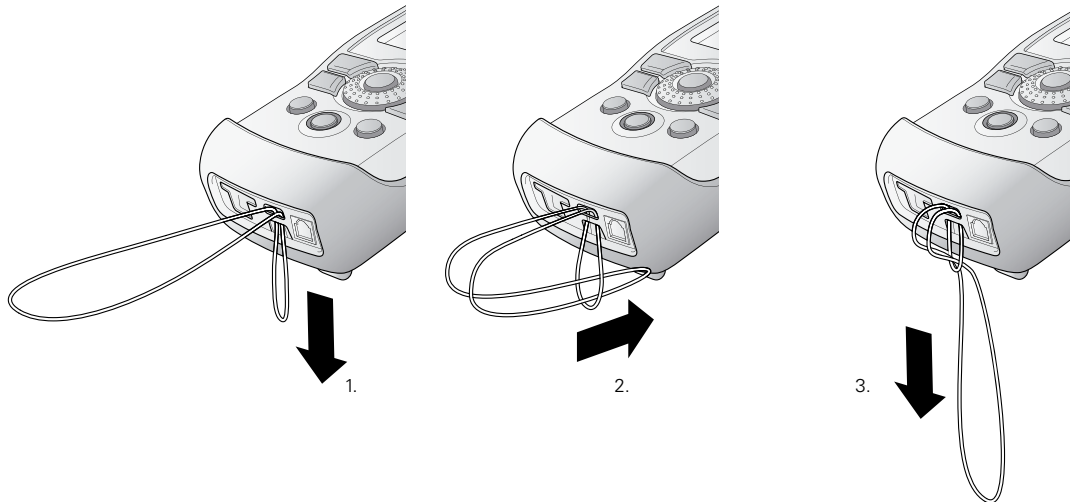

Unfold the Stand

The convenient instrument stand is attached on the rear of the instrument.

- Unfold the stand and rest the XL2 on the instrument stand.

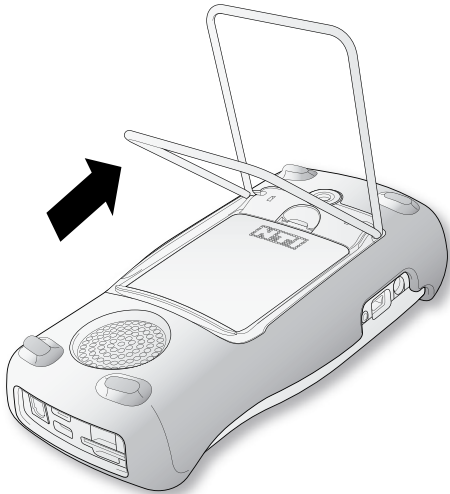

Connecting the XL2

Acoustic Measurements

Connect the measurement microphone M4260 or M2210 to the XLR input connector of the XL2.

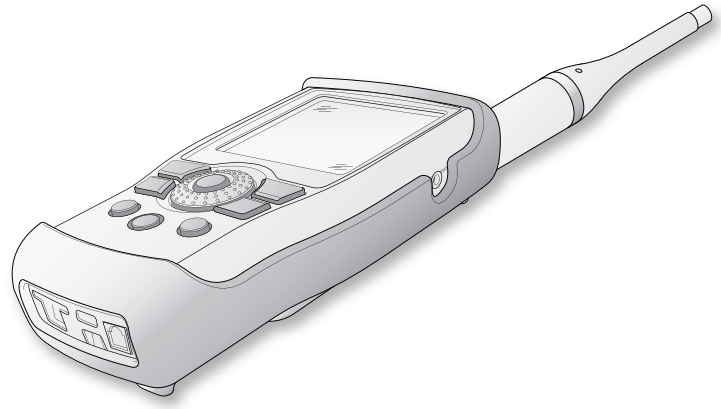

Audio Measurements: XLR Connection

- Connect the instrument to your audio device using an XLR cable.
- Select the XLR input in the menu.

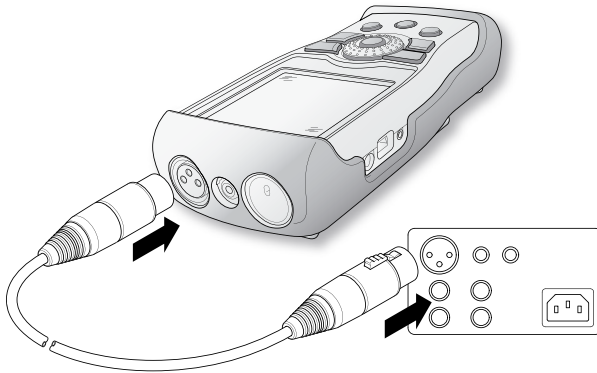

Audio Measurements: RCA Connection

- Connect the instrument to your audio device using a RCA cable.
- Select the RCA input in the menu.

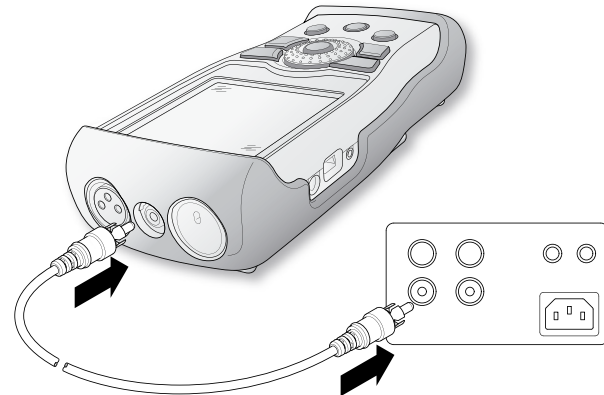

3. Basic Operation

Switching the XL2 On and Off

Switching the XL2 On

Press the power button to switch the XL2 on,

- 👉 You hear a short sound of relays. The display lighting is switched on.

Switching the XL2 Off

Press the power button and hold it down for one second to switch the XL2 off.

Instrument Settings

- To choose the measurement function select the main menu with the rotary wheel and confirm with enter .



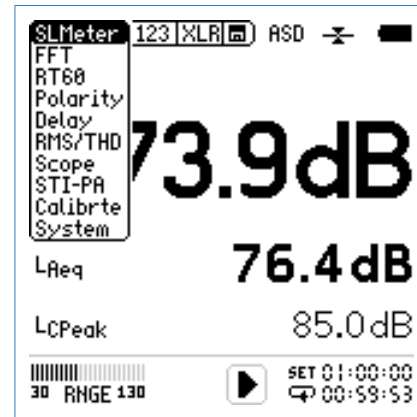





- 👉 The main menu window opens.



- Select the desired function with the rotary wheel .
- Confirm the selection with enter .

- 👉 You have now selected the measurement function.

Setting parameters using the rotary wheel

- Turn the rotary wheel .
-  The selected parameters will be marked with a black bar.
- Confirm your choice with the enter button .
-  The parameter display flashes, available parameters or available settings are shown.
- Turn the rotary wheel  to set the parameter or toggle with the enter button  through the settings.
- Confirm the setting with the enter button .
-  You have now set the parameter.

Overload Indication

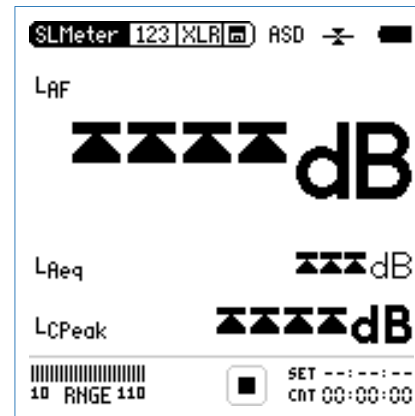

The limit arrows indicate the measured input level exceeds either the pre-set measurement range or the input range of the XL2 analyzer.

- Select a higher measurement range or reduce the input signal level as applicable.

System Settings

You can adjust various system settings of your instrument. To do this, select **System** in the main menu (1) using the rotary wheel (2) and confirm with enter (3).

System Settings Page

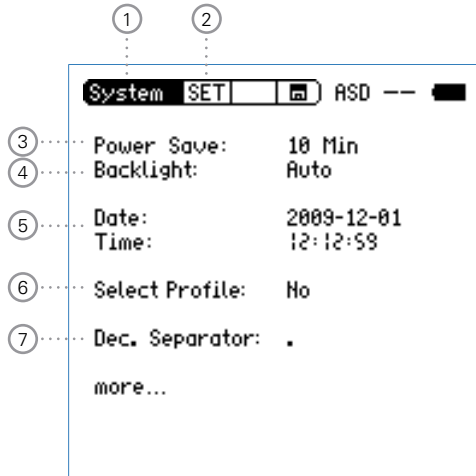

Display Contrast Setting

- Hold down the escape button `esc` and turn the rotary wheel (2) until the desired contrast is obtained.

System Information Page

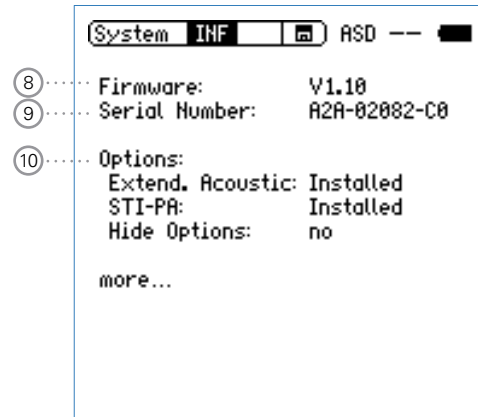



② Page Selector



Select between the system setting page and the system information page.

③ Power Save

The power save mode switches the instrument off if no button has been pressed within the selected time period.

- Use the rotary wheel  to select the **Power Save** function .
- Confirm the selection with the enter button .

 The display starts to flash.

- Turn the rotary wheel  to set the desired time.
- Confirm the entry with the enter button .

 You have set the automated switch-off time.





The power save mode is disabled in case of a running measurement or using an external mains power supply.

④ Backlight

You can choose between **Auto** and **Manual**.

Auto The backlight will be switched on automatically during operation, and will be dimmed again after a period of time.

Manual The background lighting is switched on and dimmed with the power/backlight button.

- Select the backlight  function with the rotary wheel .
- Press enter .
- Press escape  to confirm the backlight setting.

 You have set the backlight.









The dimmed backlight uses a minimum power.

5 Date/ Time

The XL2 includes a real time clock. All measurements are logged with a date- and time stamp.

Set the real time clock as follows:

- Select the **Date** function **5** with the rotary wheel .
- Press the enter button  and set the year with the rotary wheel .
- Press the enter button  and set the month with the rotary wheel .
- Press the enter button  and set the day with the rotary wheel .
- Follow the same procedure for **Time**.

 You have set the real time clock.

6 Select Profile at Power-up

The XL2 may start up with individual preset application profiles, e.g. for basic users or sound pressure level measurements according to DIN 15905 or SLV 2007.

Yes The instrument will startup with default application profiles. Read more about the application profiles in the appendix to this manual.





No The instrument will startup in the last configuration without any application profiles.

7 Decimal Separator Default

For transferring the measurement data to the PC and for generating test result reports the decimal separator default should match your PC settings. This simplifies the data import to the PC.

You can choose between “.” and “,”

- To do this, select the **Dec. Separator** function 7 with the rotary wheel .
- Press enter  and choose your setting.
- Press escape  to confirm the setting.

 You have set the decimal separator.

8 Firmware

Display of the firmware version number 8 (for updating the firmware to the latest version see the chapter “Firmware Update of XL2”).

9 Serial Number

You can read out the instrument’s serial number 9.

10 Options

Displays installed XL2 options.

4. Sound Level Meter

The XL2 provides together with the measurement microphone a precise sound level meter for monitoring of live sound events, environmental noise.

For example Actual, Lmin, Lmax, Leq are measured with frequency weighting A, C, Z and time weightings F and S at the same time. All measurement results are simultaneously available. Customers may log all acquired level information onto a removable Mini-SD card including real time information. Additionally the XL2 offers wav-file recording for a complete documentation of the measured sound pressure levels, as well voice notes might be added for each measurement. The accuracy of the XL2 exceeds IEC 61672-1, class 1. The XL2 measures correction values between the loudest point of the live event and the actual measurement positions according DIN 15905-5 and SLV 2007.

In addition to the wide band parameters the XL2 measures in parallel the real time spectrum either in 1/1 or 1/3 octave-band resolution. The RTA perfectly suits tasks, such as optimizing of sound systems

Extended Acoustic Pack (optional)

The Extended Acoustic Pack offers the following additional features for sound level- and acoustical measurements:



- Percentiles: 1%, 5%, 10%, 50%, 90%, 95%, 99%
- Time weighting: Impulse
- Sound Pressure Levels L_{Leq} , Sound Exposure Level L_{AE}
- TaktMax and values as specified in DIN 45645-1
- Digital I/O interface
- Recording of WAV-files (24 bit, 48 kHz)
- High-resolution Zoom-FFT with selectable frequency ranges and resolution up to 0.4 Hz in the range of 5 Hz - 20 kHz

The sound level meter offers different pages:

Page Selection using the Page Button

- Press the page button  to toggle between the numeric result page and the RTA page.

Page Selection using the Rotary Wheel

- Select the icon beside **SLMeter** and press enter .
- Select the sound level page **123** with the rotary wheel .
- Press enter  to confirm the selection.

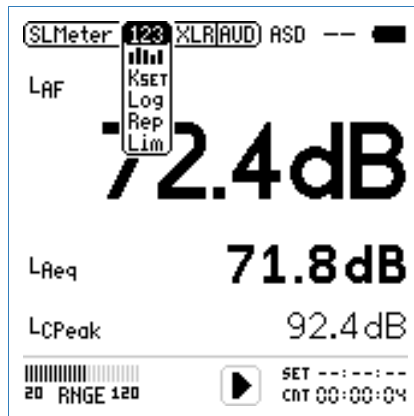

 You have selected the individual sound level meter page.

123 Sound Level Meter

Displays the selected broadband sound level results. You can change the font size of the result, thus the XL2 shows 3 or 5 results simultaneously. Individual frequency weighting, time weighting, actual, minimum, maximum and correction values can be chosen for each displayed result.

RTA Real Time Spectrum

Displays the 1/3 or 1/1 octave spectrum of the selected sound level within the audio band. Additionally the wide band result is shown graphically by a bar.

KSET Correction Value

This page is applicable for compliant sound level monitoring of live events. It measures the correction values between the actual measurement position and the loudest accessible position by the audience. The XL2 displays and logs the selected sound pressure levels including the correction values, thus the sound engineer knows the sound level at the loudest position in the audience. The measurement meets the requirements of the standards DIN15905-5 and SLV 2007. For details refer to chapter "Correction Value KSET"



Logging Page

XL2 features a powerful sound level meter data logger, that allows you to record all required sound level values during the selected period of time. In the logging page you may set which sound pressure levels shall be logged over time. You may choose between

ALL Logs all available sound pressure levels

Selective Logs up to 10 different individual defined sound pressure levels.

For details refer to chapter “Logging”.



Report Setting

Here you may set which sound pressure levels shall be stored after the completed measurement in a txt-file. You may choose between

ALL Stores all available sound pressure levels

Selective Stores up to 10 different individual defined sound pressure levels.

For details refer to chapter “Report”.



Limit LED Indication





Here you may set the function of the limit LED , thus the XL2 highlights any sound level exceeding the pre-set limit in orange or red color.

For details refer to chapter “Limit LED Indication”.



① Sound Level Result 1

All sound levels are measured and logged simultaneously. You may select the displayed sound levels.

Change Parameter

- Select with the rotary wheel  the parameter **Lxx**.
- Press the enter button  to open the selection menu to choose the wideband sound pressure level to be displayed.
- Select with the rotary wheel  the required test result parameters and confirm with the enter button .

Change Font Size

- Select with the rotary wheel  the actual test result.
- Press the enter button  1x, 2x or 3x to set the font size to small, medium or large.

The XL2 shows 3 or 5 sound levels simultaneously on the display based on the font size.

② Sound Level Result 2

Follow the setting of sound level result 1.

③ Sound Level Result 3

Follow the setting of sound level result 1.

④ Input Range

Select between the lower, mid and upper input range. The exact ranges depend on the microphone sensitivity setting in the calibration menu of your XL2.

⑤ Error Indication

OVR Overload

The error message **OVR** indicates the measured sound pressure level exceeded the pre-set measurement range during the measurement period. Once happened the **OVR** indication remains displayed for the complete measurement period.

LOW Input level too low

The error message **LOW** indicates the measured sound pressure level is below the pre-set measurement range during the measurement period. As the result is below the linear operating range the shown results are most likely higher than the actual measured sound pressure level.

⑥ Run Indication

The run indication shows the measurement status running, paused or stopped. Various measurement settings are locked during ongoing measurements, such as input ranging or preset measurement time.

⑦ Actual Measurement Time

Counts actual measurement time in hrs:min:sec. Supports setting of time modes: continuous, single, repeat or synchronized repeat in **SLMeter** mode.

CNT

Timer Mode Continuous

(applicable for standard measurements)

All values are recorded and monitored continuously after starting a measurement with the start button . The actual measurement time is shown.



Timer Mode Single

Automatically stops the measurement after the pre-set measurement time.

- Set the required measurement time.
- Start the measurement .



The actual measurement time counts back to zero and the measurement ends.

- All measurement results may be recalled.



Timer Mode Repeat

Provides automated repeated measurements with user defined preset measurement time cycles.

- Set the required measurement time.
- Press the start button .



The actual measurement time counts back to zero. As the preset measurement time is elapsed, the measurement time and the measurement results are reset and a new measurement is started. All measurement results of the previous cycle are reset.

For consecutive storage of all measurement cycles select in the **Rep** page the parameter **AutoSave On**, thus each individual cycle result is automatically stored to the Mini-SD card.



Timer Mode Repeat Synchronized

Provides automated repeated measurements synchronized to the XL2 real time clock. The measurement begins by pressing the start button . In order to align the selected preset measurement time with the real time clock, the XL2 shortens the first cycle to match the real time clock synchronization. All following measurement cycles are synchronized to the real time clock.

For example the cycle time setting is 30 minutes and the measurement starts at 7.50 a.m. -> the first test cycle measures from 7.50 - 8.00 a.m. Thereafter a new test cycle starts automatically for 30 minutes, which continuous in the repeated mode until the measurement is stopped.

The synchronized repeat timer mode is applicable at measurements for DIN 15905, thus the measurement starts exactly at the half or full hour.





Preset Measurement Time

Adjustment of preset measurement time for single and repeat timer setting.



9 Phantom Power of Microphone

The XL2 reads the electronic data sheet of the connected microphones M4260 or M2210 and switches the 48 V phantom power automatically on as follows:

- Connect the measurement microphone to the XL2.
- Switch the XL2 on by the on/off button .

 The XL2 reads the electronic data sheet of the connected microphone. The **48V** phantom power indication in the upper menu bar changes to **ASD**. The XL2 is ready for acoustical measurements.

10 Y-Scale setting

- Select the zoom factor between **20, 10, 5, 2.5 dB/div**
- Confirm the setting with enter button .
- Scroll up and down with the rotary wheel , thus selecting the displayed Y-axis range.
- Press enter  to confirm the settings.

11 RTA Measurement Result

Real time analyzer results in 1/1 octave or 1/3 octave band resolution. Adjust the resolution at .

12 X-Scale setting

Toggles X-scale range between

20 Hz - 20 kHz	RTA levels including wide band results
6.3 Hz - 8 kHz	RTA levels including wide band results
6.3Hz - 20 kHz	RTA levels without wide band results

13 Broadband Results

- A** A-weighted broadband sound pressure level
- Z** Broadband sound pressure level without any frequency weighting

14 Cursor Readout and Display Setting



Actual level result of the indicated frequency band in the RTA page. The cursor readout displays the center frequency and the level of the band pointed to by the arrow. The cursor automatically follows the highest level band in the spectrum.

Alternatively the cursor readout may be controlled manually:

- Select the arrow next to the frequency read out field and press the enter button .

 The arrow is flashing.

- Select the frequency with the rotary wheel .

 The cursor readout  displays the reading of the selected band.

- Press enter . The cursor returns to the frequency with highest level bar.

The XL2 offers two individual read out values for a preset **Lxx**:







Test results shown with dashes in the RTA graph.



Test results shown with bars in the RTA graph.

15 Setting of Test Result Resolution

Set the RTA result display to 1/1 octave or 1/3 octave band resolution as follows:

- Select with the rotary wheel  the parameter .
- Press the enter button  to toggle between **1/1 OCT** and **1/3 OCT**.
- Press the escape button  to confirm your setting.

Error Indications

Numeric Result Page

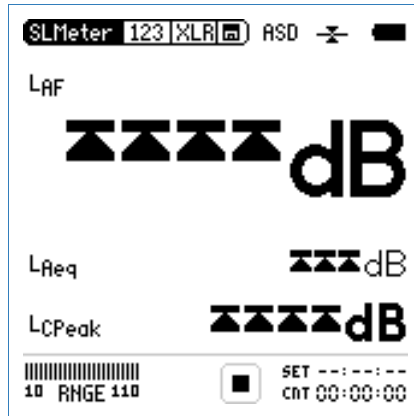

Real Time Analyzer Page

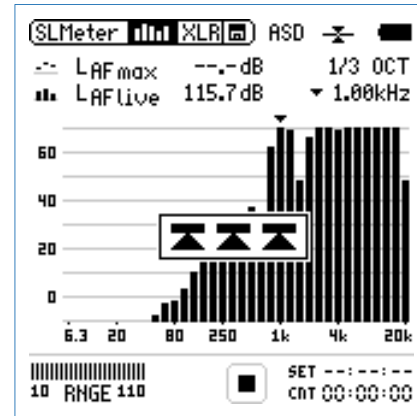

The limit arrows indicate the measured input level exceeds either the pre-set measurement range or the input range of the XL2 analyzer.

- Select a higher measurement range or reduce the input signal level as applicable.

Correction Value K_{SET}

The loudest point of the audience area has to be measured at live event monitoring. The XL2 is commonly positioned at a convenient accessible location, e.g. front of house. In order to display the sound pressure level at the loudest point in such applications does the XL2 measure the difference between the loudest position and the actual measurement position. Thus during the live event the sound pressure level of the loudest point is displayed and recorded automatically. This ensures that all attendees to the concert enjoy sound pressure levels within the permitted limits.

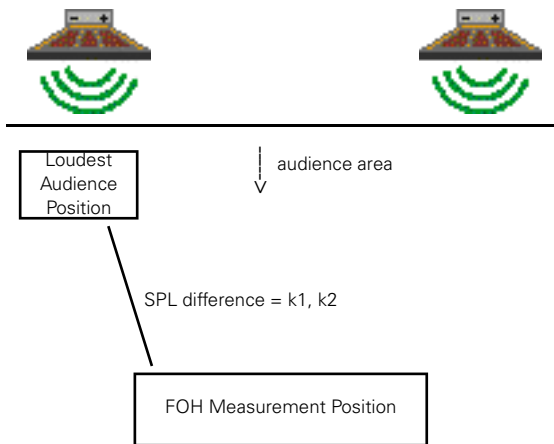

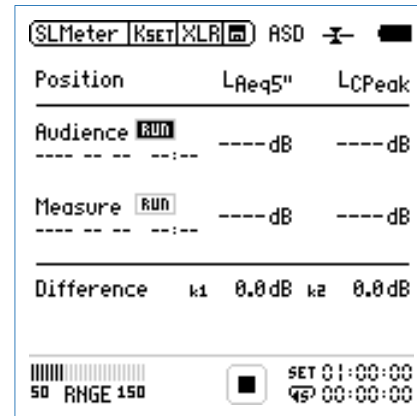

How to Measure the Correction Value

- Play a pink noise signal at the typical sound pressure level of the live event. The pink noise signal is generated e.g. by the Minirator or the NTi Audio Test CD.
- Position the XL2 in the audience at the point with the highest sound pressure level.
- Select with the rotary wheel the parameter **RUN** next to **Audience** and press the enter button .



- The timer counts from 5 seconds down to zero and the sound level measurement is carried out automatically.



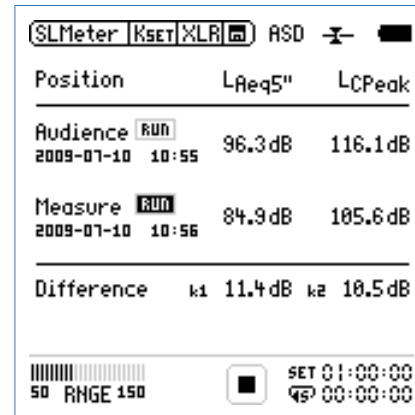
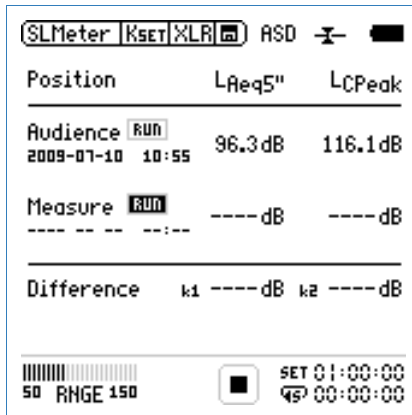



- Position the XL2 at the measurement point used during the live event.
- Select with the rotary wheel  the parameter **RUN** next to **Measure** and press the enter button .
- The timer counts from 5 seconds down to zero and the sound level measurement is carried out automatically.

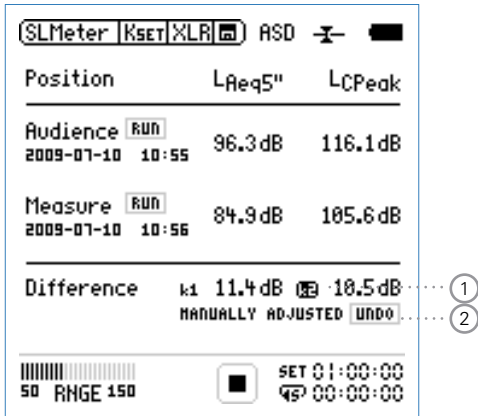

Manual Setting of Correction Values

You may fine tune the correction values k1 and k2 manually. Such fine tuning will add the remark "Manually Adjusted" in the log file.



- Set the correction value with the rotary wheel .
- The note "Manually Adjusted" is displayed at  .
- To undo the manual setting select with the rotary wheel  the parameter **UNDO** at .
- Confirm by pressing the enter button .

- Select with the rotary wheel  the correction value  and press the enter button .

 The selected correction value starts flashing.

Logging

The XL2 features a powerful sound level meter data logger **LOG**, which allows you to record all required sound level values during the selected period of time. All results are logged onto the Mini-SD card. The measurement results can be loaded to PC for documentation and visualization.

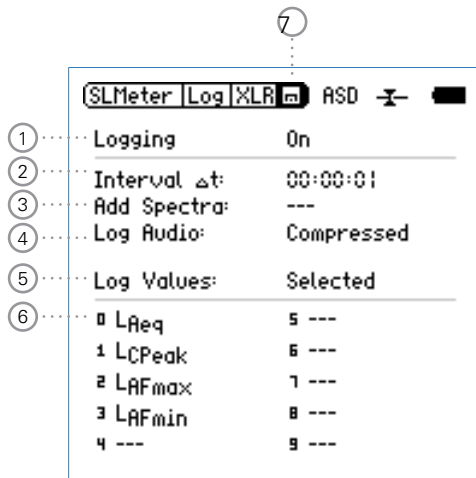

① Logging On/Off

Select **Logging** with the rotary wheel and enable/disable the automated logging of test results by pressing the enter button .

② Interval Δt

Adjust the logging interval.

③ Add Spectra

Select **Yes** to log additionally the RTA spectrum at each logging interval.

④ Log Audio

The XL2 logs audio data as wav-file. For more details read the chapter "Wave File Recording".

24Bit_48kHz Optional: Audio logging in 24 bit, 48 kHz resolution; part of the optional Extended Acoustic Pack

Compressed Audio logging in ADPCM form



Off Audio logging is off

5 Log Value Setting

You may choose between the following result logging:

ALL Logs all available sound pressure levels without correction values.

Selected Logs a subset of up to 10 different sound pressure levels, selected sound levels may include correction values.



- Select **Log Values** with the rotary wheel .
- Press enter  to toggle between **All** and **Selected**.

6 Selected Log Values

By setting **Selected** at 5 up to 10 individual log values can be chosen.

- Select the first value **Lxx** with the rotary wheel  and press the enter button .

 The pop up window for level selection shows up.

- Select the logging level with the rotary wheel  and confirm with the enter button .

7 Display of Ongoing Logging

A flashing **LOG** indicates an ongoing data logging.

Reporting

A report saves the conducted measurements onto the installed Mini-SD card. You may even set the sound pressure levels to be stored in the report after the measurement is completed.

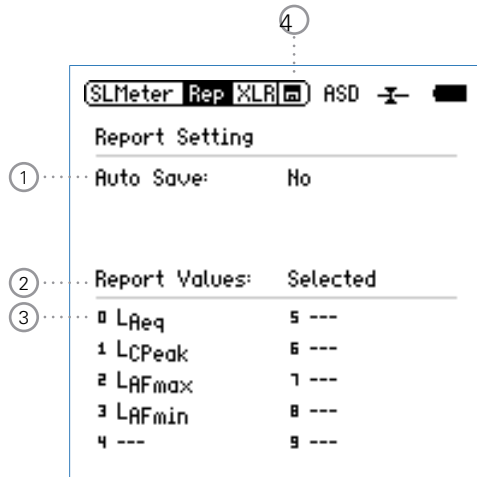

① Auto Save

- Yes** The test results are stored automatically after the completed test cycle, e.g. applicable for repeated sound level measurements.
- No** The test results shall be stored manually within the memory menu.

② Reported Values

You may choose between the following result reporting:

- ALL** Records all available sound pressure levels without correction values.
- Selected** Records a subset of up to 10 different sound pressure levels, selected sound levels may include correction values.

- Select **Reported Values** with the rotary wheel
- Press enter to toggle between **All** or **Selected**.

③ Selected Report Values

By setting **Selected** at ② up to 10 individual report values can be chosen.

- Select the first value **Lxx** with the rotary wheel and press the enter button .

The pop up window for level selection shows up.

- Select the reporting level with the rotary wheel and confirm with the enter button .

④ Display of Non-Saved Reports

A flashing **?** indicates an non-saved measurement report.

Wave File Recording

The XL2 records wave files of the measured acoustical signal. The recorded wave files are by default AD-PCM compressed or optionally available in 24 bit, 48 kHz resolution. All wav-files are stored automatically on the Mini-SD card with a typical filename of 004AUDIO.wav. The uncompressed wav-file logging in 24bit, 48kHz resolution is part of the optional Extended Acoustic Pack.



The advantage of wave file recordings is to identify and document sound sources after the measurement, e.g.: At a live event an excessive peak level of 115 dB has been measured and recorded. Actually this peak level has been caused by shouting persons nearby the measurement microphone, thus not caused by the actual monitored audio system. The recorded wave file will prove this and test results can be post processed. Another example is environmental noise monitoring: Listening to the recorded wave file after the measurement may help to determine the predominant sound source.



In case of any ongoing measurement is paused , the XL2 continues the recording of wav-files during the paused period. The logged data and audio data can be synchronized using the stored real time information.

Voice Notes



Voice notes are recorded voice annotations, which uses the internal voice note microphone.

- Select the Mini-SD card symbol  with the rotary wheel  and confirm with enter .

 The memory menu opens.

- Select **Voicenote** and press enter .

 The pop up window **VOICENOTE** appears.

- Select **REC** and press enter .
- Now record your voice note and then press enter  to finish the recording.

 The voice note has been stored on the Mini-SD card as a wav-file, e.g. named as 002VNOTE.wav.



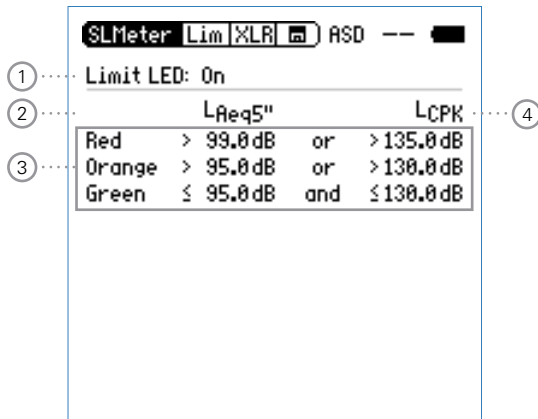

Limit LED Indication

The limit page controls the function of the limit LED , thus the XL2 highlights any sound level exceeding the pre-set limit in orange or red color. The default color is green.





① Limit LED On/Off

Select **Limit LED** with the rotary wheel  and enable/disable the limit function by pressing the enter button .





② Sound Level 1

You may select one or two sound levels for the limit LED indication .

- Select the sound level field  with the rotary wheel .
- Press enter  and select the sound level for the limit LED indication.

③ Selected Sound Level Values

Set the sound level values for the limit LED  here.

- Select the first sound level in  with the rotary wheel  and press the enter button .
- Set the sound level value with the rotary wheel  and confirm with the enter button .

④ Sound Level 2

Follow the above setting of sound level 1.

Sound Level Meter - Getting Started

Test Preparations

The XL2 reads the electronic data sheet of the connected microphones M4260 or M2210 and switches the 48 V phantom power automatically on as follows:

- Connect the measurement microphone to the XL2.
- Switch the XL2 on by the on/off button .

 The XL2 reads the electronic data sheet of the connected microphone. The **48V** phantom power indication in the upper menu bar changes to **ASD**. The XL2 is ready for acoustical measurements.



- Position the XL2 at the measurement location, e.g. using a microphone stand.
- Select the **SLMeter** function in the measurement menu and toggle with the page button  to the numeric result page.





All wideband- and RTA levels are measured and logged simultaneously. You may select the displayed sound levels.

Select Displayed Test Result

This example describes the setting of the commonly used actual sound pressure level L_{AF} (frequency weighting A, time weighting F).

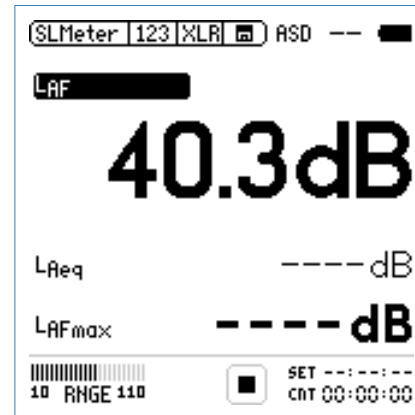
- Select the first parameter setting with the rotary wheel .
- Press enter  to confirm the selection.



Sound levels results indicated with ---- will be measured and displayed upon pressing the start button .

Select Frequency Weighting

👉 The pop-up window **FREQ WEIGHTING** shows up.

- Select the frequency weighting **A**.



Pop up windows shown at installed
Extended Acoustic Option

- Press enter ↵ to confirm the setting.

Select Time Weighting

👉 The pop-up window extends with **Time Weighting**.

- Select the required time weighting, e.g. **F** (=Fast).

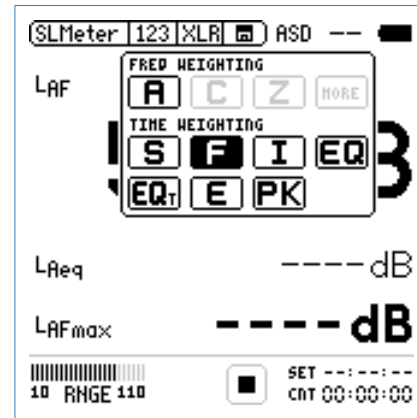

- Press enter ↵ to confirm the setting.

Select Parameter

👉 The pop-up window extends with **Parameter** settings.

- Select the parameter **live**.

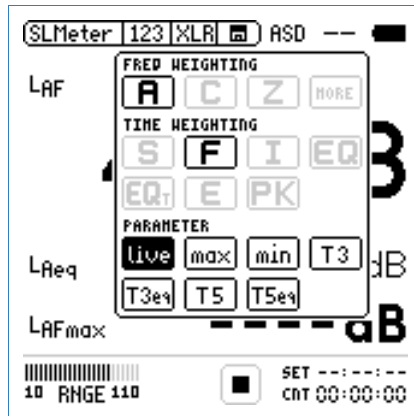

- Press enter ↵ to confirm the setting.

Select Correction Value

👉 The pop-up window extends with **Correction** settings.

- Select the parameter **off**.

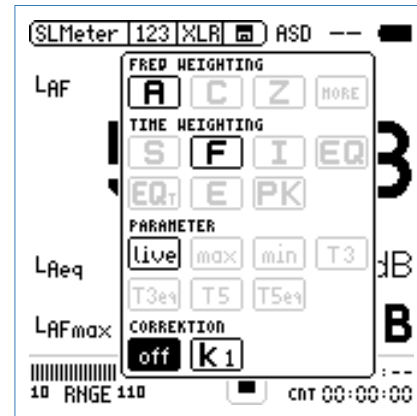

- Press enter ↵ to confirm the setting.

Select further Sound Levels

- 👉 The pop up window closes and the measured sound pressure level L_{AF} is displayed.



- Select further sound pressure level parameters to be displayed as described before, e.g. L_{eq} and L_{AFmax} .

Select Input Range

- Select the input range according to the maximum expected level during the measurement including sufficient headroom. Wrong input ranges are indicated by a flashing **LOW** or **OVR** message in the lower menu bar.
- Select the input range **RNGE** and press enter ↵.
- Turn the rotary wheel ⌚ for setting of the applicable input range and confirm your setting with pressing enter ↵.

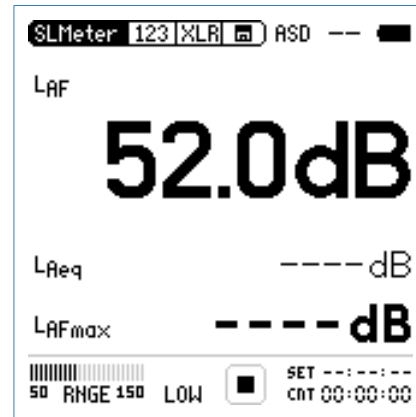

The numeric result page and the real time analyzer page use the same input range.

Start Measurement

- The XL2 is ready to measure the sound levels L_{AF} , L_{eq} and L_{AFmax} .
- Press the start button .

👉 The run indication switches to running. The integrated sound pressure level over time L_{eq} and the maximum level in the measurement period L_{AFmax} are displayed. The parameter **LOG** is flashing in the Mini-SD card field. In case of any preset audio recording the parameter **AUD** is flashing in the Mini-SD card field.

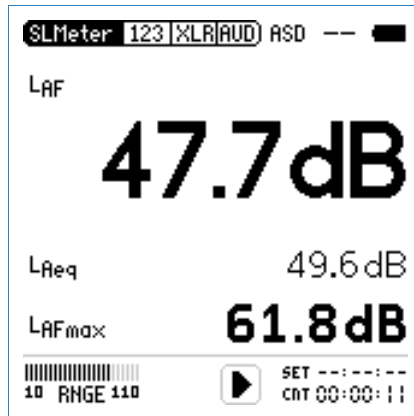

Stop the Measurement

- Stop the measurement by pressing the stop button .

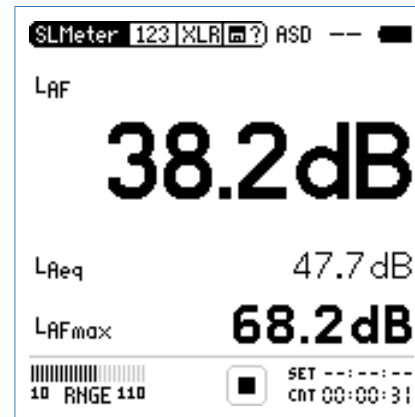

Save the Measurement Result

Save the recorded measurement results.

- Select the Mini-SD card symbol with the rotary wheel and confirm with enter .

The memory menu opens.

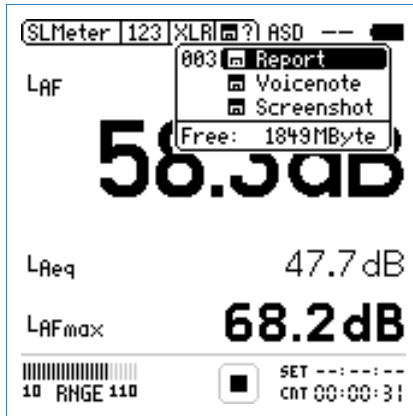

- Select **Report** to store the test results as ASCII-file or select **Screenshot** to store the screenshot.



The XL2 stores the numeric sound pressure levels and the real time analyzer results simultaneously.

The sound pressure level measurement is completed.

RTA Measurement - Getting Started

Test Preparations

The XL2 reads the electronic data sheet of the connected microphones M4260 or M2210 and switches the 48 V phantom power automatically on as follows:

- Connect the measurement microphone to the XL2.
- Switch the XL2 on by the on/off button

The XL2 reads the electronic data sheet of the connected microphone. The **48V** phantom power indication in the upper menu bar changes to **ASD**. The XL2 is ready for acoustical measurements.

- Position the XL2 at the measurement location, e.g. using a microphone stand.
- Select the **SLMeter** function in the measurement menu and toggle with the page button to the real time analyzer page.



All wideband- and RTA levels are measured and logged simultaneously. You may select the displayed sound levels.

RTA Configuration

The XL2 displays two different sound pressure levels at the same time. You can personalize the displayed test results and numeric read out values as follows e.g. L_{ZFmax} and L_{ZF} .

- Ensure no other measurement is going on. The run indication shall display the stop symbol.
- Select the **LZF** value with the rotary wheel .

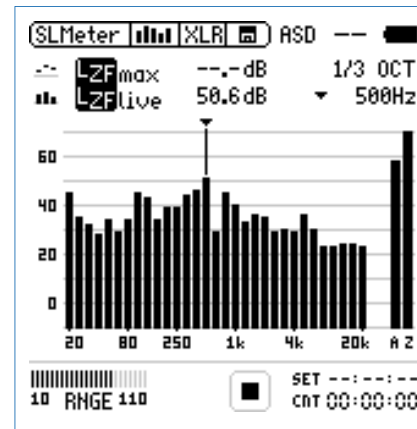

- Press the enter button .

Select RTA Frequency Weighting

👍 The pop-up window **FREQ WEIGHTING** shows up.

- Select the frequency weighting **Z**.

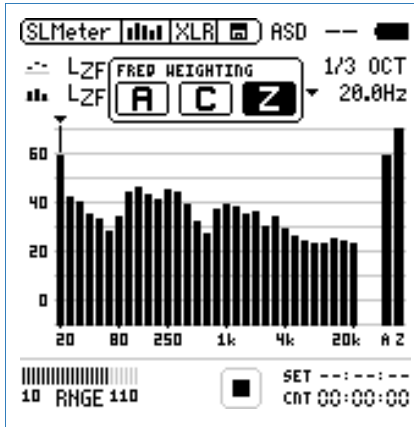

- Press enter to confirm the setting.



Sound levels results indicated with ---- will be measured and displayed upon pressing the start button .

Select RTA Time Weighting

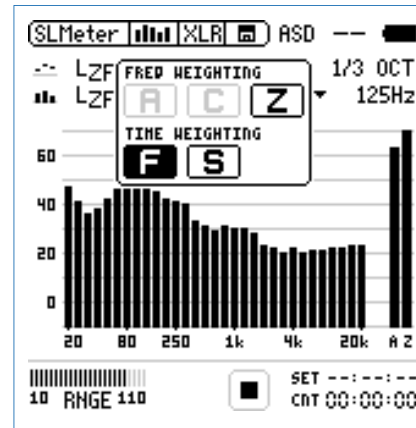

👍 The pop-up window extends with **Time Weighting**.

- Select the required time weighting, e.g. **F** (=Fast).



- Press enter to confirm the setting.

Select Upper RTA Parameter

- Select the parameter shown right of the upper **LZF** value with the rotary wheel , e.g. **max**.
- Press the enter button .

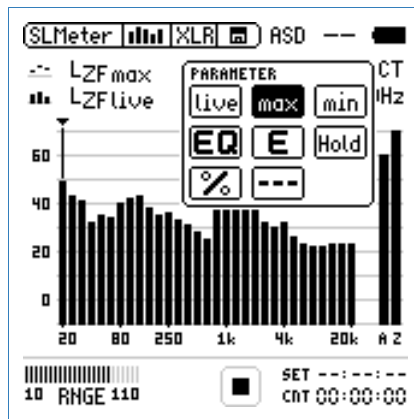

 The pop-up window **Parameter** shows up.

- Select the parameter **max**.



- Press enter  to confirm the setting.

Select Lower RTA Parameter

- Select the parameter shown right of the lower **LZF** value with the rotary wheel , e.g. **live**.
- Press the enter button .

 The pop-up window **Parameter** shows up.

- Select the parameter **live**.

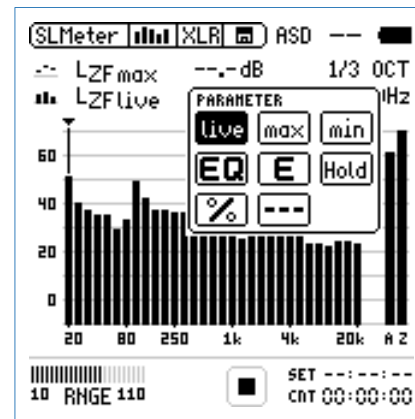

- Press enter  to confirm the setting.

Select Input Range

- Select the input range according the maximum expected level during the measurement including sufficient headroom. Wrong input ranges are indicated by a flashing **LOW** or **OVR** message in the lower menu bar.
- Select the input range **RNGE** and press enter ↵ .
- Turn the rotary wheel ⦿ for setting of the applicable input range and confirm your setting with pressing enter ↵ .

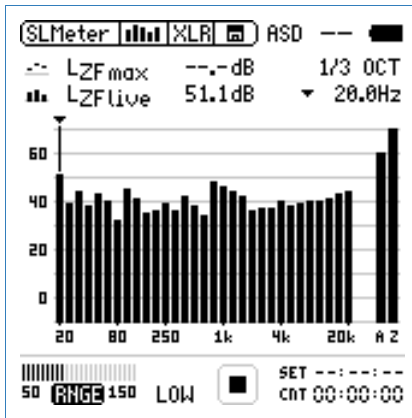

The numeric result page and the real time analyzer page use the same input range.

Start RTA Measurement

- The XL2 is ready to display the measured sound pressure levels L_{ZFmax} and L_{ZF} .
- Press the start button ▶ .

☺ The run indication switches to running. The actual sound level L_{ZFlive} and the maximum level L_{AFmax} are displayed. The parameter **LOG** is flashing in the Mini-SD card field. In case of any preset audio recording the parameter **AUD** is flashing in the Mini-SD card field.

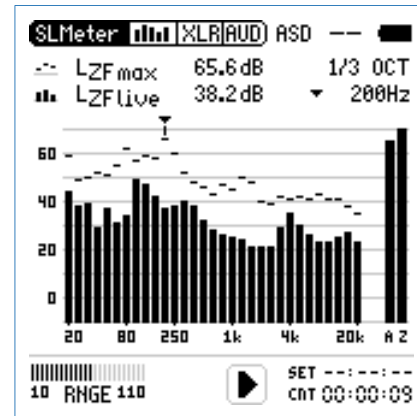

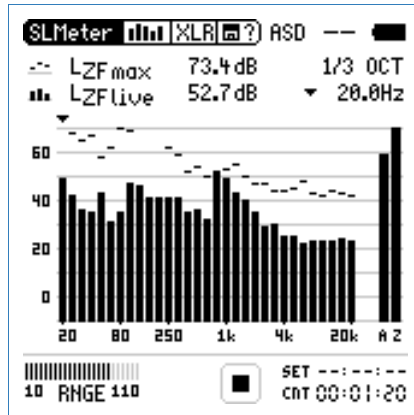

Stop the RTA Measurement

- Stop the measurement by pressing the stop button .



The XL2 stores the numeric sound pressure levels and the real time analyzer results simultaneously.

Save the RTA Measurement Result

- Select the Mini-SD card symbol  with the rotary wheel  and confirm with enter .

👉 The memory menu opens.

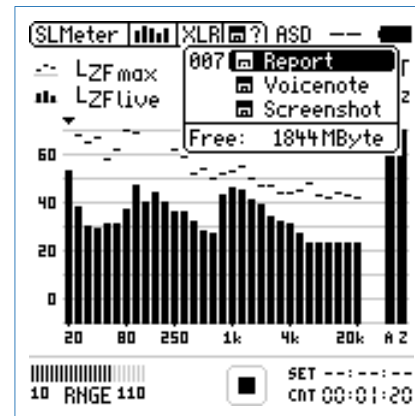

- Select **Report** to store the test results as ASCII-file or select **Screenshot** to store the screenshot.

👉 The RTA measurement is completed.

5. Acoustical Analyzer

The XL2 Audio and Acoustic Analyzer offers besides the comprehensive sound level meter also the following acoustical measurement functions:

- FFT Analysis
- Reverberation Time RT60
- Polarity
- Delay time
- Speech intelligibility (optional)

FFT Analysis

The FFT measurement is the ideal tool for visualization of comb filters and narrow band effects. It allows a detailed investigation of the frequency response in audio systems. The XL2 includes an extremely fast, real-time FFT. The display shows 142 bins simultaneously.

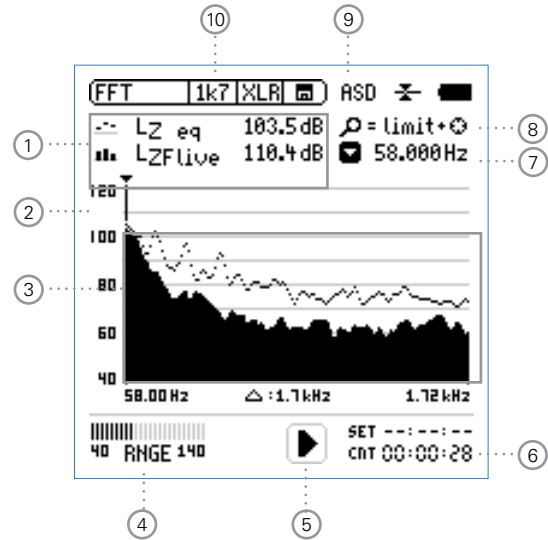

① FFT Measurement Result

The XL2 offers two individual read out values L_{ZF} (no frequency weighting, fast time weighting)





Test result of L_{Zeq} , averaged sound pressure level over time



Test result of L_{ZFlive} , actual sound pressure level

② Y-Scale setting

- Select the zoom factor between **20, 10, 5, 2.5 dB/div** and confirm the setting with enter button .
- Scroll up and down with the rotary wheel , thus selecting the displayed Y-axis range.
- Press enter  to confirm the settings.

③ FFT Measurement Result

Displays the actual and averaged FFT measurement results.

④ Input Range

Select between the lower, mid and upper input range. The exact range depends on the microphone sensitivity setting in the calibration menu of your XL2. The input range setting is disabled during ongoing measurements.

⑤ Run Indication

This icons indicates a running, paused or stopped measurement status.

⑥ Actual Measurement Time

Counts actual measurement time in hrs:min:sec.

⑦ Readout Frequency

Selectable frequency to read out the individual FFT level. The selected frequency is pointed by the cursor arrow. The cursor automatically follows the highest FFT level.

The cursor readout may be controlled manually:

- Select the arrow next to the frequency read out field and press the enter button .



The arrow is flashing.

- Select the frequency with the rotary wheel .







The cursor readout  displays the reading of the selected band.

- Press enter . The cursor returns to the frequency with the highest level bar.

⑧ Zoom Mode

(applicable with the optional Extended Acoustic Package)

- Select the read out frequency ⑦ and press the enter button .
- The zoom mode is displayed above the flashing arrow.
- Select the zoom-in frequency with the rotary wheel .
- Press the limit button and zoom with the rotary wheel  in or out in the linear frequency scale.
- Press the limit button and scroll with the rotary wheel  left or right in the linear frequency scale.

⑨ Phantom Power of Microphone

The XL2 reads the electronic data sheet of the connected microphones M4260 or M2210 and switches the 48 V phantom power automatically on as follows:

- Connect the measurement microphone to the XL2.
- Switch the XL2 on by the on/off button .

 The XL2 reads the electronic data sheet of the connected microphone. The **48V** phantom power indication in the upper menu bar changes to **ASD**. The XL2 is ready for acoustical measurements.

⑩ Page Selector X-Scale Setting

Select the X-scale range between

- 20k** Shows FFT result of the frequency range. 484.38 Hz - 20.594 kHz in a resolution of 141.62 Hz with 142 bins shown on the display.
- 1k7** Shows FFT result of the frequency range. 58 Hz - 1.722 kHz in a resolution of 11.72 Hz with 142 bins shown on the display.
- 200** Shows FFT result of the frequency range. 7 Hz - 215.01 Hz in a resolution of 1.47 Hz with 142 bins shown on the display.
- usr** Customized zoom mode (applicable with optional Extended Acoustic Pack) 5 Hz - 20 kHz in zoom mode with a minimum resolution of 0.366 Hz and 142 bins shown on the display.

The page key  toggles between these display modes.

FFT Analysis - Getting Started

Test Preparations

- Connect the measurement microphone to the XL2.
- Switch the XL2 on by the on/off button

The XL2 reads the electronic data sheet of the connected microphone. The **48V** phantom power indication in the upper menu bar changes to **ASD**. The XL2 is ready for acoustical measurements.

- Position the XL2 at the measurement location, e.g. using a microphone stand.

Select FFT Input Range

- Select the input range according the maximum expected level during the measurement including sufficient headroom. Wrong input ranges are indicated by a flashing **LOW** or **OVR** message in the lower menu bar.
- Select the input range **RNGE** and press enter .
- Turn the rotary wheel for setting of the applicable input range and confirm your setting with pressing enter .

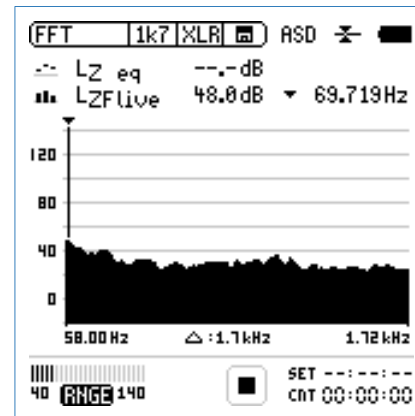

Start and Stop the FFT Measurement

- The XL2 is ready to display the measured sound pressure levels L_{Zeq} and L_{ZF} live.
- Press the start button . This starts the measurement of the integrated sound level L_{Zeq} .

👉 The run indication switches to running.

- Stop the measurement by pressing the stop button .

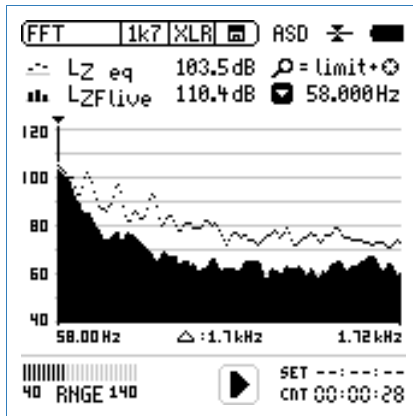

👉 The L_{Zeq} and L_{Zeq} are measured simultaneously.

Save the FFT Measurement Result

- Select the Mini-SD card symbol with the rotary wheel and confirm with enter .

👉 The memory menu opens.

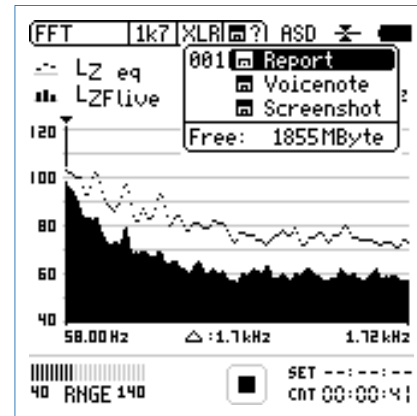

- Select **Report** to store the test results as ASCII-file or select **Screenshot** to store the screenshot.

👉 The FFT measurement is completed.

Reverberation Time RT60

The XL2 measures the energy decay from 63 Hz to 8 kHz by the Schroeder method. As test signal serves either an impulse source or a gated pink noise.

What is Reverberation Time RT60?

Reverberation time RT60 is the time required for the sound pressure level to decrease by 60 dB after the sound stimulus signal is stopped. Since ambient noise often defeats measurements of 60 dB level decrease in practice, the RT60 results are measured as T20 reverberation time results, thus a decrease of 20 dB is measured. This requires a measurement signal-noise ratio of only 35 dB, whereby the 35 dB are derived by the 20 dB decay together with 5 dB upper- and 10 dB lower noise range within each octave band.

RT60 Run Page **RUN**

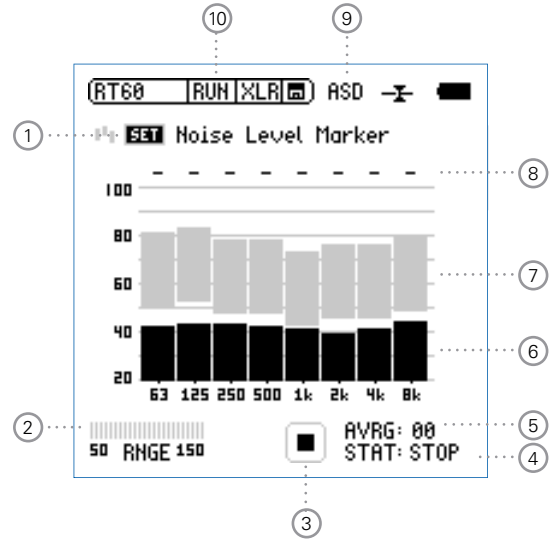

RT60 Average Result Page **RES**

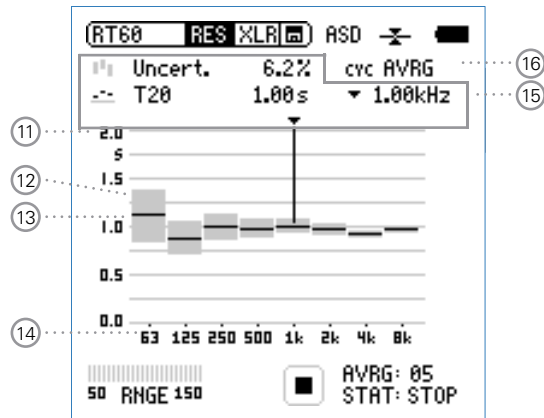

RT60 Cycle Result Page **RES**

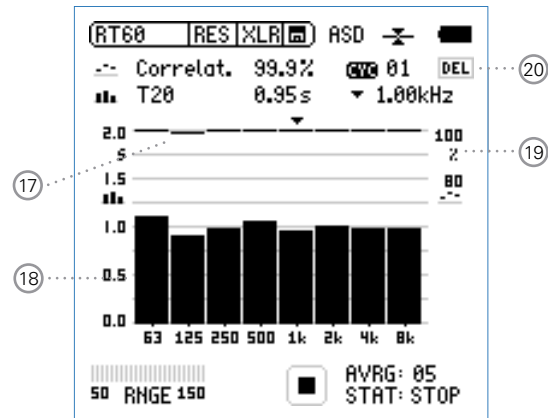

① Set Level Markers

Prior conducting a reverberation time measurement the environmental noise is measured, thus setting the required energy level of the test signal.

- Select **SET** and press the enter button  to measure the actual environmental noise.

 The required level marker appears in grey color.

② Input Range

Select between the lower, mid and upper input range. The exact ranges depend on the microphone sensitivity setting in the calibration menu of your XL2.

③ Run Indication

This icons displays the running and stop status of the reverberation time measurement. It is controlled by the start/stop button .

④ Measurement Status STAT

Displays the actual measurement status. Start and stop the reverberation time measurement by pressing the XL2 start/stop button . The following status information might be displayed:

ARMED Measurement is waiting for the test signal exceeding at least one measurement trigger marker, thus the measurement will be triggered automatically.

NOISE Test signal exceeds the trigger marker.

DECAY Ongoing decay of the test signal.

PAUSE The measurement has been paused by pressing the pause button .

STOP No RT60 measurement is presently carried out.

⑤ Average AVRG



Counts the measurement cycles. At using a gated noise test signal a minimum of 3 cycles are recommended to be carried out sequentially.

⑥ Actual Real Time Spectrum

The black bars indicate the actual background noise. At setting up the reverberation time measurement you may increase the test signal level, thus the black bars exceed the grey bars completely.

⑦ Level Marker

The grey bars indicate the required noise level for the reverberation time measurements in each octave band. The marker has a length of 35dB, which can be obtained by

- Selecting **SET** ① with the rotary wheel .
- Press enter  to measure the environmental noise in the silent room.

⑧ Band Status

Indicates a successful reverberation time measurement at the individual octave band.

⑨ Phantom Power of Microphone

The XL2 reads the electronic data sheet of the connected microphones M4260 or M2210 and switches the 48 V phantom power automatically on as follows:

- Connect the measurement microphone to the XL2.
- Switch the XL2 on by the on/off button .

 The XL2 reads the electronic data sheet of the connected microphone. The **48V** phantom power indication in the upper menu bar changes to **ASD**. The XL2 is ready for acoustical measurements.

10 Page Selector RT60

Select between the RT60 run page and the test result page.



RT60 run page



RT60 result page. Toggle with the measurement result selection 16 between

AVRG RT60 average result page

CYC xx RT60 cycle result page

Last Last RT60 cycle result page

The page button  toggles between these displays.

11 Y-Axis Reverberation Time

Reverberation time in seconds. The scaling is automatically adjusted.

12 Uncertainty Factor

The uncertainty factor is displayed in the RT60 average result page. It indicates the uncertainty of the averaged measurement results. The uncertainty factor depends on the measured reverberation time, the cycles and the bandwidth of the individual frequency band, thus lower bands will show a higher uncertainty factor. The uncertainty factor reduces as more cycles are measured. The number of measurement cycles is displayed at 5.

13 Overall Reverberation Time Test Result

Read out of reverberation time and uncertainty factor 12.



Measurement results uncertainty. For more details see 12.



Reverberation time measurement results.

14 X-Axis

RT60 Octave Bands 63Hz - 8 kHz

15 Cursor Readout

Select the individual octave band and read out the following numeric measurement results

- Uncertainty factor in % or correlation in %.
- Reverberation time RT60 of the selected octave band.

16 Measurement Result Selection

The RT60 measurement function enables consecutive reverberation time measurements within one test sequence. An averaged test result of all measurements is automatically calculated.



Select **CYC** and toggle with the rotary wheel  through the individual test result cycles showing

Last Last Test R result

Displays the result of last measurement cycle.

xx Single Test Cycle Results

The individual single test results are marked with **CYC xx**, where **xx** is an incriminating number. You may delete individual test results thus the averaged reverberation time result uses only the remaining valid measurements. Delete cycle results as follows:

- Select **DEL** with the rotary wheel 
- Confirm with the enter button .

AVRG Averaged Test R result



The averaged test results of all taken measurements are calculated and displayed.

17 Correlation Factor in %

The correlation factor will be 100% for perfect linear sound pressure level decay after the sound source has ceased. The natural deviation from the linearity results in lower correlation values. The correlation factor is typically 80 - 100%.

18 Cycle Reverberation Time Test Result

Read out of cycle reverberation time and correlation factor

 at selection  = **CYC xx** or **Last**.



Correlation Factor. For more details see .



Reverberation time measurement result of individual displayed cycle.

19 Y-Axis Correlation Factor

The right Y-axis shows the correlation factor in %. The correlation factor Y-axis is displayed at test result selection is **CYC xx** or **Last**. Read more at .

20 Delete Cycle Results

Individual cycle results may be deleted, thus they are not used for the calculation of the **AVRG** result.



Test Signals

The sound source shall be as omni-directional as possible. As test signal serves either an impulse source or gated pink noise.

- Gated pink noise

Various gated pink noise test signals with different on/off time are offered by the accompanying NTi Audio Test CD or the Minirator signal generator.

- Impulse

The trigger signal is a generated impulse source, such as a gun shot. Individual single measurements or test sequences can be carried out by repeated trigger signals.

The XL2 measures the reverberation time of several on/off cycles and automatically averages the reverberation time results. The uncertainty factor is calculated after a minimum of three measurement cycles.

RT60 Measurement - Getting Started

Test Signal: Pink Noise

The room under test is injected with a pink noise signal through an omni-directional speaker. The sound source has to be active until balance between injected and absorbed acoustical energy has been reached. Then the source signal has to be stopped. The XL2 recognizes this interruption, triggers, measures the decay time and calculates the reverberation time automatically.

Test Signal: Impulse

The room under test is injected by an impulse sound source e.g. by a gun shot. The XL2 measures the decay time & calculates the reverberation time automatically.

Test Preparations

The XL2 reads the electronic data sheet of the connected microphones M4260 or M2210 and switches the 48 V phantom power automatically on as follows:

- Connect the measurement microphone to the XL2.
- Switch the XL2 on by the on/off button

The XL2 reads the electronic data sheet of the connected microphone. The **48V** phantom power indication in the upper menu bar changes to **ASD**. The XL2 is ready for acoustical measurements.

- Position the XL2 at the measurement location, e.g. using a microphone stand.
- Select the **RT60** function in the measurement menu and toggle with the page button to the run page.
- Prepare the environment for the measurement. i.e. mute all sound sources to establish silence.

Set Level Markers

- Select the parameter **SET** with the rotary wheel and press the enter button .

The environmental noise is measured and the grey level markers are set.

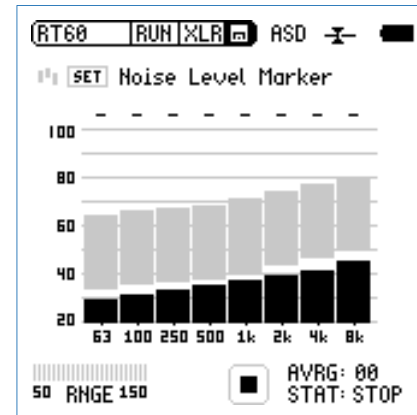

Get Ready for the Reverberation Time Measurement

- Protect your ears against high sound pressure levels, as the test signals might be very loud.

Using pink noise:

- Start the pink noise test signal with the appropriate on/off time according to the room under test. Use an initial low sound pressure level.
- Increase the test signal level until all level markers for the minimum test signal level are passed. As required use an equalizer pushing individual band levels.
- Upon completing switch off the gated pink noise signal.

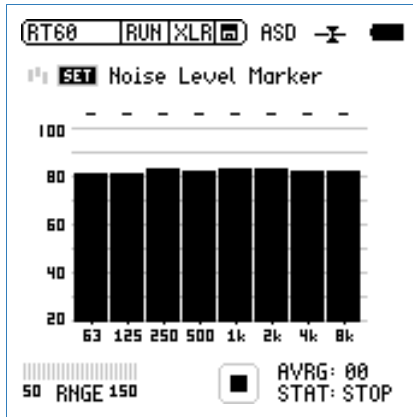

Start the Measurement

- Press the start button . The status indication switches to **ARMED**.
- Enable the test signal, e.g. switch on the gated pink noise signal or fire a gun shot.
- The black bars have to exceed the grey bars completely.

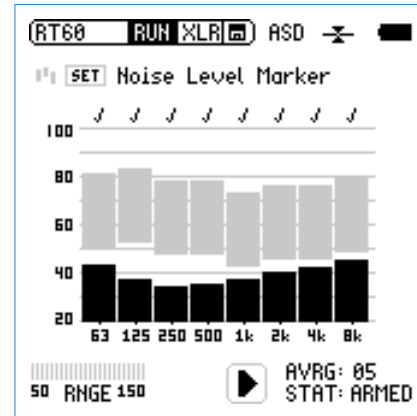

- The RT60 is calculated when the sound pressure level has fallen below the lower noise level marks in each individual octave band.
- Confirmation marks are displayed in the setup page for successful measurements.

Continue the Measurement

Using pink noise:

The gated pink noise test signal continues with the pre-set on/off time. The XL2 automatically triggers at each cycle. Complete minimum three test cycles, thus the uncertainty factor is calculated.

Using an impulse source:

For repeated measurements and automated averaging of more results use further gun shots as required.

- Press the pause button to pause the measurement.
- Prepare the next impulse sound source, e.g. gun shot.
- Press the start button to continue the reverberation time measurement.
- Enable the test signal, e.g. fire a gun shot.

Stop the Measurement and Read Out the Result



- Press the stop button after the measurement is completed.
- If applicable switch off the pink noise test signal.
- Select the result page with the page button .

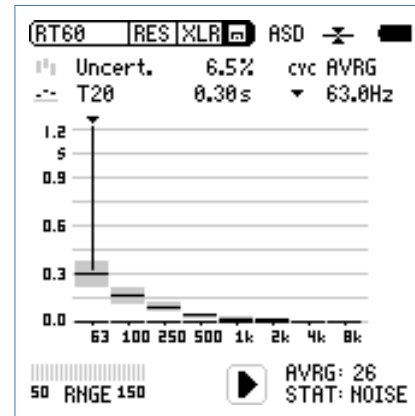

The overall reverberation time results is displayed in seconds and the measurement uncertainty in %. For more details refer to chapter "Reverberation Time RT60".



Read Out the Individual Cycle Result

- Select **CYC** with the rotary wheel , press the enter button  and select the individual cycle result with the rotary wheel .



The cycle result is displayed in seconds and the correlation factor in %. For more details refer to chapter "Reverberation Time RT60".

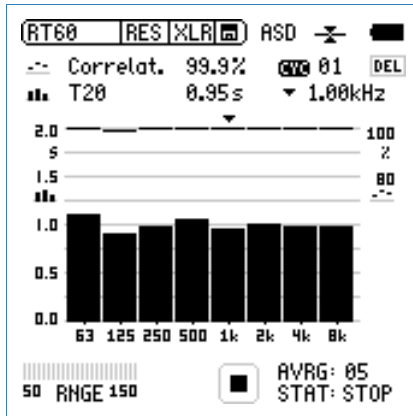

 The RT60 reverberation time is measured.

Error Indications

Various error indications display non successful RT60 measurements. Corrupt individual measurements can be deleted individually. Non-valid results are excluded from average calculations.

• LOW LEVEL

This is the abbreviation of "low test signal level" during the measurement. Increase the test signal level and verify that all levels are exceeding the level markers. Use a corresponding RT60 test signal with longer on/off times, so the lower level mark can be reached.

• CORR<70%

The correlation factor is lower than 70% indicating an unreliable measurement result.

• T>18S

The measured reverberation time exceeds the time limit of 18 seconds, e.g. commonly caused by an incorrect analyzer range setting or by environmental noise. In this case repeat the ranging and start the measurement again.

Polarity

The polarity measurement is important to match the left and right speaker for a good stereo sound image. The polarity function measures the polarity of cables, single speakers and speaker cabinets. As test signal servers the polarity signal provided on the NTi Audio Test CD or the Minirator test signal generator.

The polarity of individual speakers or speaker cabinets might change with the frequency, such as the polarity of the mid-range speaker may differ to the woofer polarity within the same speaker cabinet. Therefore the detailed result page displays the measured polarity of the individual octave bands from 125 Hz to 8 kHz. This allows in-depth verification of the polarity - frequency relation.



- The polarity testing is a simplified measurement of a very complex signal phasing. Drivers, speakers and crossovers cause severe phase shifts of the audio signal.
- The polarity of various speakers within the same cabinet may differ. The polarity is a result of the speaker design.
- Polarity testing is useful for checking the correct wiring of similar speaker systems.

Positive/Negative Page

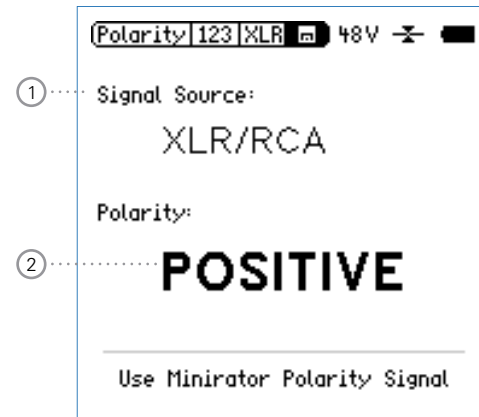

Detailed Result Page

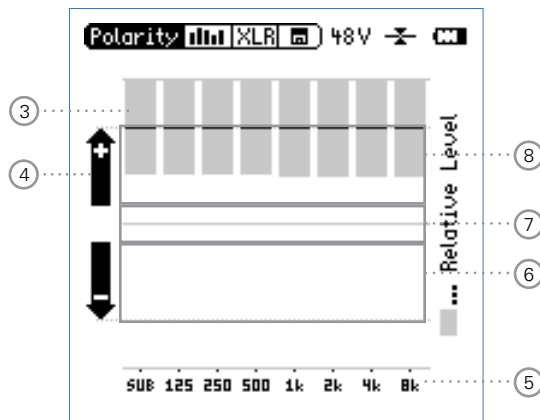

Polarity result of Minirator directly
connected to XL2 Analyzer

① Input Selection

Select the used signal source as follows:

- Select **Signal Source** with the rotary wheel .
- Press the enter button  to select either

VOICE Using the internal voice note microphone of the
NOTE XL2 for polarity measurements. This selection
MIC disables the rear speaker.

XLR/ Measure the acoustical polarity with the M4260
RCA or M2210 measurement microphone. Alterna-
tively measure the polarity of an electrical signal
connected with an audio cable. Set the input
selector in the upper menu accordingly.

② Polarity Test Result

Displays either **POSITIVE**, **NEGATIVE** or ??? (=undefined).
For visual indication the limit button  illuminates green at
POSITIVE polarity and red at **NEGATIVE** polarity.

③ Relative Level Indicator

The grey area shows the measured signal energy within
the individual frequency bands. The bands with the biggest
energy will effect the actual displayed **POSITIVE / NEGA-**
TIVE polarity result the most.

④ Polarity Indication

- + Polarity of frequency band is positive. The polarity result is in the upper display area, the + area.
- Polarity of frequency band is negative. The polarity result is in the lower display area, the - area.

⑤ X-Axis

Seven octave bands with center frequencies from 125 Hz to 8 kHz. **SUB** displays the polarity of sub woofers, frequency range < 100 Hz.

⑥ Negative Polarity Area

Measurement results area with negative polarity (-). The black line in the middle of relative level indicator ③ displays the measured polarity of the individual frequency band. The dashed line shows the lower limit of the measurement result area.

⑦ Uncertain Polarity Area ???



Polarity results of frequency bands in this area are uncertain, thus positive/negative page displays the polarity result ???.

⑧ Positive Polarity Area

Measurement results area with positive polarity (+). The black line in the middle of relative level indicator ③ displays the measured polarity of the individual frequency band. The dashed line shows the upper limit of the measurement result area.

Polarity Measurement - Getting Started

For the acoustical polarity measurement you can use the internal voice note microphone, thus no external plug-on microphone is required. The polarity result of left and right speaker cabinet have to match for a stereo sound image.

- Feed the speaker cabinet with the polarity test signal of the Minirator.
- Adjust the test level (at Minirator or amplifier) thus the test signal is good to hear.
- Enable the polarity test signal at the left speaker cabinet; mute the right speaker cabinet.
- Select **Signal Source** with the rotary wheel  and choose **VOICE NOTE MIC** with the enter button , thus the internal microphone is used for the polarity measurement.
- Measure the polarity of left speaker cabinet.
- Enable the polarity test signal at the right speaker cabinet; mute the left speaker cabinet.
- Measure the polarity of the right speaker cabinet.
- Compare the polarity test result of speaker cabinets.

 The polarity is measured.

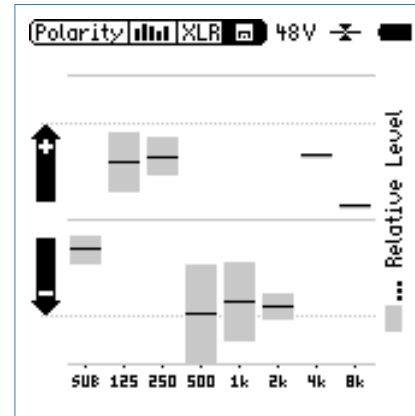

The sample result shows the polarity as follows:

- Sub woofer: Low energy, no sub installed
- Woofer: Positive
- Mid-range: Negative
- Tweeter: Positive (with small levels)

The major part of the signal energy is measured in the mid-range frequency bands, thus the overall displayed polarity is **NEGATIVE**.

Delay Time

The delay time measurement function suits the accurate setup of delay line arrangements, thus the directionality of the signal source will be optimized. The XL2 measures the delay time between the electrical reference signal and the acoustical signal from the speaker. The required acoustical delay settings are displayed automatically, thus the audio engineer may set the measured delay time directly at the delay device in the rack.

The NTi Audio delay time test signal is provided either by the Minirator MR-PRO, MR2 or the included Test CD.

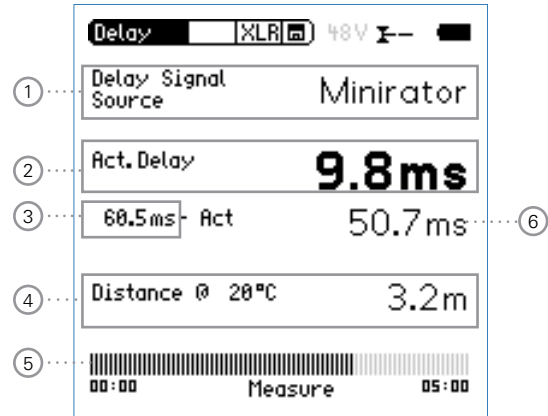

① Delay Signal Source

Select the used signal source for the delay measurement:

CD Player Using the supplied NTi Audio Test CD; this setting implies the synchronization time bar is set to 100 seconds = 1 min. 40 sec.; after 100 seconds the XL2 has to be synchronized to the delay test signal again.

Minirator Due to the known accuracy of the Minirator MR-PRO or MR2 test signal, the XL2 offers an extended time range without synchronization. After 300 seconds (5 min.) the XL2 has to be synchronized to the delay test signal again.

② Actual Delay

Actual measured delay time referring to the electrical reference signal.

③ Reference Delay Time

Individually stored reference delay time of e.g. speaker A as described in the following chapter "Delay Measurement - Getting Started".

④ Calculated Distance

Distance from measurement position to speaker in meter or feet, based on the preset temperature in °C or °F

⑤ Synchronization Time Bar

The automated synchronization allows delay time measurements without any connected electrical reference signal for 100 seconds using the NTi Audio Test CD or 300 seconds using the Minirator MR2 or MR-PRO. It displays the time remaining for the next required synchronization.

⑥ Automatically Calculated Delay Time: Store - Actual

Calculated difference between delay time of speaker A and speaker B shown on next page. The automated difference calculation simplifies the verification of delay line arrangements, e.g. used in larger halls or auditoriums.



Rear Speaker

The rear speaker is disabled in the delay measurement function, thus avoiding measurement failures. The headphone output is active.

Delay Measurement - Getting Started

The delay time measurement is conducted between the synchronized electrical input signal and the acoustical signal measured at the built-in voice note microphone. In this example the required delay between speaker A and B in the below auditorium is measured.

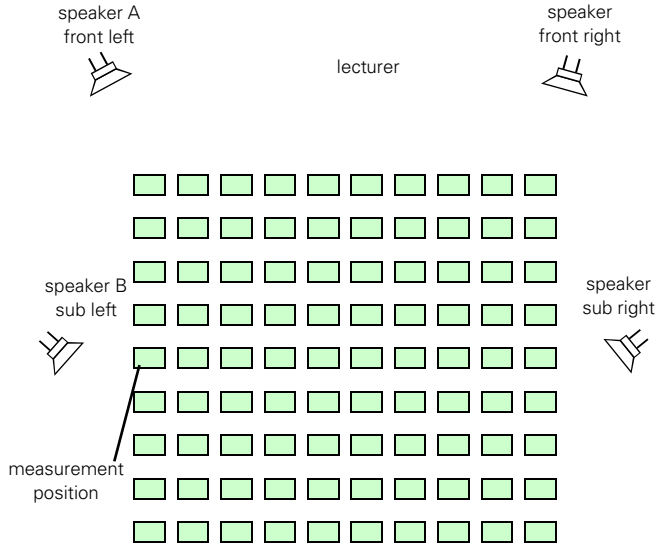

Test Preparations

- Get the delay test signal ready provided either by the NTi Audio Test CD or the Minirator test signal generator.
- Start the delay test signal.
- Select the used input XLR or RCA in the upper XL2 menu.
- Connect the generated delay test signal by an audio cable to the preset RCA or XLR input of the XL2. For example the reference signal may also be taken from an auxiliary channel of a mixing console.
- Set the actual environment temperature, thus the distance is displayed correctly later.

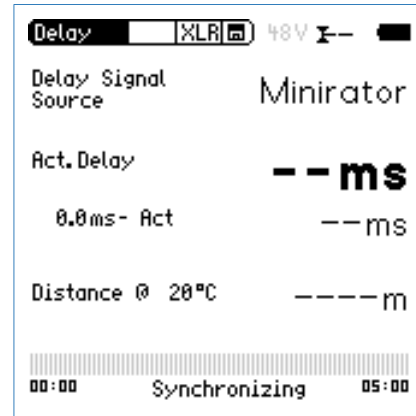

- Wait until the XL2 synchronizes to the incoming delay test signal, then the synchronization time bar fills up.

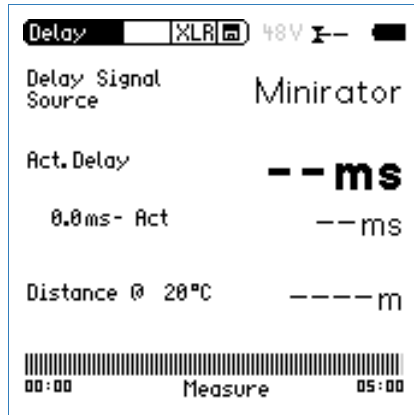

- You may disconnect the audio cable with the synchronizing signal from the XL2. This allows you to move around freely for the delay measurement. At delay signal source selection **Minirator** the XL2 has to be synchronized after 5 minutes to the signal source again. In case the delay signal source is **CD Player**, then the XL2 has to be synchronized every 100 seconds.

Measure Reference Speaker A

- Start the delay test signal at speaker A, mute speaker B.
- Position yourself with the XL2 at the shown measurement position, thus you measure the acoustical delay in the sound field next to sub speaker B, which is the worst case position in the auditorium.

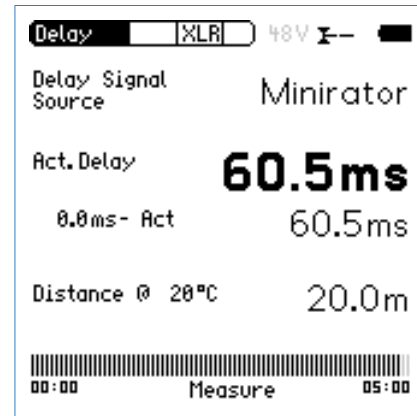

👉 The XL2 measures the delay time of speaker A in reference to the electrical input signal in milliseconds.

Store Reference

- Select the displayed **0.0 ms** below **Act. Delay** with the rotary wheel and press the enter button .

The reference result of speaker A is stored for the difference calculation of delay A - B.

- Stop the delay test signal at speaker A.

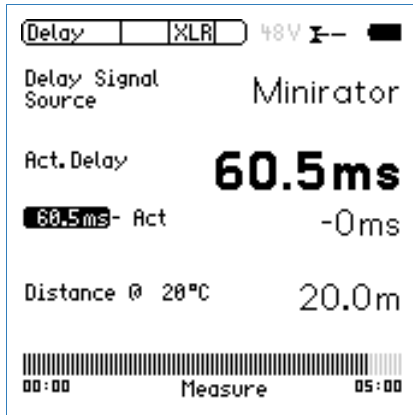

Measure Sub Speaker B

- Start the delay test signal at speaker B. Mute speaker A.
- Position yourself with the XL2 at the shown measurement position.

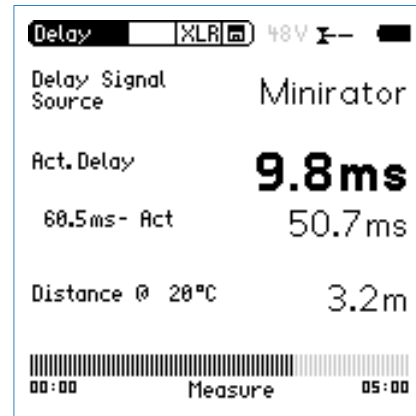

The XL2 measures the delay time of speaker B in reference to the electrical input signal in milliseconds.

Automated Difference Calculation

- The delay time difference between speaker A and B is automatically calculated and shown below the **Act. Delay** result.



The delay time is measured.

	<p>Result Interpretation</p> <ul style="list-style-type: none"> • The resulting time in milliseconds shows the time difference of the sound signal from speaker A and B arriving at the measurement position. Speaker B has to be delayed by the displayed difference result. • For best directionality add a safety margin of 5 ms to the calculated difference, thus the main signal from speaker A arrives at the measurement position first. The acoustic signal from sub speaker B arrives 5 ms later. This improves the subjective directionality pattern of the listeners.
--	--



Do not position the XL2 too close to reflecting surfaces, such as walls or floors. The reflections may likely prevent accurate measurements.



Distance in meter/feet

The distance results in meter/feet are displayed below for easy verification of the test results accuracy. The readings are based on 330 m/s sound speed at 0°C / 32°F.

Speech Intelligibility STI-PA (optional)

The STI-PA analyzer option allows reliable measurement of the speech transmission index within 15 seconds. Besides the single value STI or CIS test result, a detailed view of the modulation indices and individual band level results is provided. The STI-PA analyzer meets the latest 2003 IEC 60268-16 standard.

The speech intelligibility measurement STI-PA is an option for the XL2 Audio and Acoustic Analyzer. Ask your local representative for purchasing details.

STI-PA Signal Source

NTi Audio TalkBox	<p>The NTi Audio TalkBox simulates a person talking at a precise acoustical level, enabling the measurement of the complete signal chain including the microphone</p> <ul style="list-style-type: none">• Place the NTi Audio TalkBox in front of the microphone at the typical position of the talking persons head.• Select Track 1 for the STI-PA test signal.• Select Output Mode to Speaker; you should hear the STI-PA test signal.
Minirator MR-PRO	<p>The Minirator MR-PRO is used for electrical signal injection at public announcement systems, which commonly use alarm messages from a hard drive (systems without a microphone).</p>
CD Player	<p>The included NTi Audio CD "STI-PA V1.1" can be used with a professional CD player, for details see chapter "STI-PA Measurement Hints"</p>

STI-PA Numeric Result Page

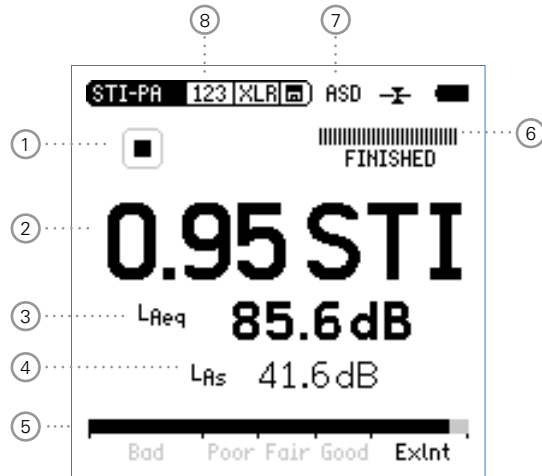

STI-PA Table Result Page

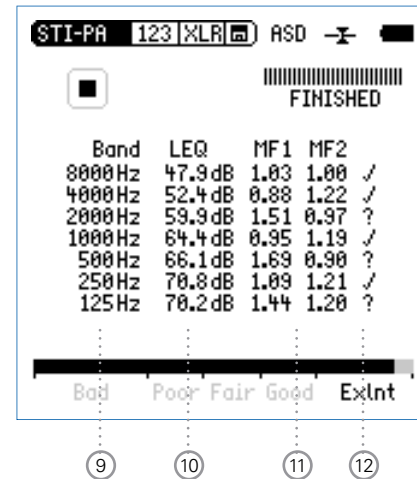

① Run Indication

This icon displays the run status of the STI-PA measurement.

② STI-PA Measurement Result

Single value speech transmission index result in STI (speech transmission index) or CIS (common intelligibility scale), whereby CIS is calculated as $CIS = 1 + \log STI$.

③ Sound Level L_{Aeq}

Shows the time-averaged sound level of the 15 seconds STI-PA measurement cycle time.

④ Sound Level L_{AS}

Shows the actual sound pressure level, including A-weighting and slow time weighting according to IEC 60268-16 standard.

⑤ Analog STI-PA Bargraph

Bargraph display and interpretation of the speech intelligibility measurement result

- Bad 0.00 - 0.30 STI
- Poor 0.30 - 0.45 STI
- Fair 0.45 - 0.60 STI
- Good 0.60 - 0.75 STI
- ExInt 0.75 - 1.00 STI

⑥ Progress Bar

Measurement status indication; the single STI-PA measurement takes 15 seconds, thus the actual measurement time and measurement status are indicated here.

⑦ Phantom Power of Microphone

The XL2 reads the electronic data sheet of the connected microphones M4260 or M2210 and switches the 48 V phantom power automatically on as follows:

- Connect the measurement microphone to the XL2.
- Switch the XL2 on by the on/off button .

 The XL2 reads the electronic data sheet of the connected microphone. The **48V** phantom power indication in the upper menu bar changes to **ASD**. The XL2 is ready for acoustical measurements.

⑧ Page Selector STI-PA

Select between the available result pages:



STI-PA numeric result page



STI-PA table result page, detailed results per octave band

The page button  toggles between these displays.

⑨ STI-PA Octave Bands

Frequencies 125 Hz - 8 kHz in 1/1 octave band resolution.

Sound Pressure Level L_{eq}

⑩ Individual time-averaged octave band level L_{eq} .

⑪ STI-PA Modulation Index MF1, MF2

For good speech intelligibility it is mandatory that the integrity of the transmitted voice signal modulations are preserved. Therefore STI-PA is based on measuring the MTF (Modulation Transfer Function). This function quantifies the degree to which the voice modulations are preserved in individual octave bands. STI-PA determines the MTF by analyzing the seven frequency bands, whereby each band is modulated with two frequencies, resulting in the modulation index 1 and index 2. These two indexes combined will give the single value STI-PA result.

12 Error Detection

The STI-PA measurement function has a built in error detection which helps you identifying faulty measurements. The error detection checks the following parameters:

- Invalid modulation indices (MF1 or MF2 > 1.3)
- Irregularities during ongoing measurements

Both parameters depend on the amount of impulsive environmental noise, which influences any STI-PA measurement and makes the values inaccurate.

The STI-PA numeric result page displays the measurement result interrupted by the flashing “?.??” question marks if the error detection finds any problem. Furthermore octave band results detected with irregularities, are marked in the STI-PA table result page with a question mark (?). The error indication might be caused either by

- Missing test signal level
- Impulsive background noise events

If the error detection finds any faults, then repeat the measurement and compare the STI-PA test result with the previous ones.

STI-PA Measurement - Getting Started

Test Preparations

The XL2 reads the electronic data sheet of the connected microphones M4260 or M2210 and switches the 48 V phantom power automatically on as follows:

- Connect the measurement microphone M4260 or M2210 to the XL2.
- Switch the XL2 on by the on/off button .

 The XL2 reads the electronic data sheet of the connected microphone. The **48V** phantom power indication in the upper menu bar changes to **ASD**. The XL2 is ready for acoustical measurements.

- Position the XL2 at the measurement location, e.g. using a microphone stand.
- Select the **STI-PA** measurement function in the measurement menu and toggle with the page button  to the STI-PA numeric result page.
- Prepare the environment for the measurement. i.e. mute all sound sources to establish silence.



Preconditions for STI-PA measurement:

- No impulsive noise events should occur during the 15 seconds measurement time. Even relatively moderate level noise may affect the STI-PA test result.
- To avoid measurement failures the STI-PA signal level L_{eq} should be minimum 60 dB SPL in the measured area.
- The STI-PA measurement should be carried out at emergency conditions (same sound pressure level and all components activated).
- During the measurement should be no speaking or other noise sources allowed near the measurement microphone.

Measure Environment Noise

- Verify the actual sound pressure level of the environment as shown on the XL2 display.
- Mute all disturbing noise.

Start STI-PA Test Signal

- Switch on the STI-PA test signal at your signal source.
- Set the acoustical sound pressure level of the PA system according to the typical emergency condition requirements, e.g. $L_{AS} = 85$ dB.



Start STI-PA Measurement

- Press the start button  on the XL2.
- 👉 The progress bar switches to **RUNNING**. The test result tendency is shown on the STI-PA bargraph, marked with **Bad, Poor, Fair, Good** and **ExInt**.







Stop STI-PA Measurement

After the period of 15 seconds the STI-PA measurement finishes automatically. The progress bar indications switches to **FINISHED** and the final STI-PA test result is displayed.

- Switch off the STI-PA test signal at your signal source.



Store STI-PA Measurement Result

- Store the test result by selecting the Mini-SD card symbol  with the rotary wheel .
- Press the enter button .
- Select **Report** to store the test results as ASCII-file or select **Screenshot** to store the screenshot.
- Confirm by pressing the enter button  again.



The detailed STI-PA test result view of the modulation indices and individual band level results is provided on the second STI-PA measurement page, accessible by the page selector or by pressing the XL2 page button .

 The speech intelligibility STI-PA is measured.

STI-PA Post Processing

Measuring the speech intelligibility index under realistic environment conditions is often not applicable, e.g. playing the test signal in a railway station at emergency levels during peak hours will irritate passengers. Additionally at rush hours the characteristics of back ground noise might be highly impulsive. But a pre-requisite for accurate STI-PA measurements is a negligible impulsivity in the background noise.

Under such circumstances the STI-PA measurement should be shifted to a more suitable time of the day, e.g. night time. Such STI-PA measurements taken at untypical background noise conditions have to be post-processed. Post processing combines the STI-PA measurement data taken at quasi noise-free ambient conditions with the unweighted time-averaged octave band noise levels (Leq) taken e.g. during day time, at realistic environmental conditions.

The NTi Audio STI-PA Post Processing Software is tailored for this application e.g. to combine the night and day-time measurement.

“NTi_Audio_STI-PA_PostProcessing.xlt” is available for download at “www.nti-audio.com”; Products: XL2.
(Enable all macros at opening the document.)

STI-PA Measurement Hints

- Any background noise has to be sufficiently static during the measurement, e.g. pink noise fulfills this requirement.
- Verify the environmental conditions prior testing. Complete STI-PA measurements without any test signal. The results shall be < 0.20 STI.
- Impulsive background noise during the measurement, such as speech, cause severe measurement errors. The STI-PA result is usually too high.
- In case such an impulsive noise cannot be prevented, the measurements might be shifted e.g. to night time, and afterwards corrected with the averaged daily background noise, using external post processing.
- In case such impulsive noise can not be prevented, the measurements might be shifted e.g. to night time, and afterwards corrected with the averaged daily background noise, using external post processing.
- Any CD-Players used to reproduce the STI-PA test signal have to be accurate as only limited time-shifts (± 200 ppm) are allowed to ensure reliable STI-PA test results. Pitch control and shock protection shall be disabled. Thus only professional players shall be used. You may verify the time shift of your CD-Player with a 1 kHz test signal:
 - Insert the NTi Audio Test CD into the CD player and start track 1, which is the 1 kHz test signal.
 - Connect the XL2 directly to the audio output and measure the signal frequency in the RMS/THD mode. The displayed frequency shall be in the range from 0.9998 kHz to 1.0002 kHz
- STI-PA test signals of other test system manufacturers may sound similar but are not compatible. Only the NTi Audio STI-PA test signal CD V1.1 or higher shall be used in combination with the XL2.
- STI-PA measurement of alarm systems should be carried out at emergency conditions (same sound pressure level and all components are activated).
- At locations with varying conditions e.g. some public areas with few people; others with crowds – the worst case STI-PA results should be measured. Consult your local regulations (e.g. in the U.S., the NFPA code) for specific directives concerning measurement locations and number of required total STI-PA measurements under different circumstances.
- Select typical locations based upon such regulations, or typically position the microphone at 1 - 1.2 meters above ground in sitting areas or 1.5 - 1.8 meters in standing areas (typical measurement positions are normally not directly in front of the speakers).
- The person taking the measurements should be out of the acoustic field, so not affecting the measurement results. For this purpose the measurement microphone can be mounted on a microphone stand and connected with the ASD-Cable to the XL2.

- Low STI-PA readings can be caused by
 - Excessive sound reverberation, echoes or reflections
 - Poor speaker directivity or speaker coverage
 - Speaker power setting not in order (e.g. low signal-to-noise ratio)

6. Audio Analyzer

The XL2 Audio and Acoustic Analyzer offers besides the comprehensive sound level meter- and acoustical measurement functions also the analog audio measurement functions **RMS /THD** and **Scope**.

RMS / THD

The XL2 Audio and Acoustic Analyzer measures the parameters Level RMS, THD+N and frequency simultaneously.

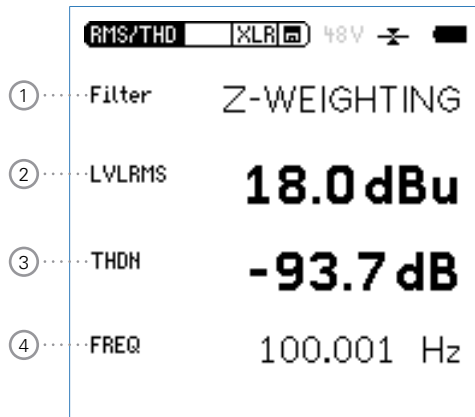

① Filter

The following filter settings are available:

- | | |
|--------------------|--|
| Z-Weighting | Z-Frequency weighting with flat frequency response from 20 Hz to 22 kHz. Default measurement setting. |
| A-Weighting | A-Frequency weighting measuring residual noise of the unit under test acc. to IEC 61672 e.g. in sound broadcasting. |
| C-Weighting | C-Frequency weighting for special applications, such as noise measurements according to IEC 61672 at higher levels. |
| HP 400Hz | Highpass 400 Hz acc. to DIN 45045 -120dB/dec., attenuates mains frequency (50/60Hz) components of the test signal. |
| HP 19k | Highpass 19 kHz attenuates all audio frequency components from the test signal, e.g. to measure a 20 kHz pilot tone level of a public announcements systems without disturbing the public. |

② Level RMS

Measures the absolute level of the input signal. The units dBu, dBV and V are selectable.

③ THD+N

Measures the total harmonic distortion and noise of the input signal. The distortion measurement, expressed in dB or in %, is conducted within the bandwidth 10 Hz - 20 kHz.

④ Frequency in Hz

The XL2 automatically extracts and measures the frequency of the basic fundamental signal. The XL2 frequency counter technology even reads the frequency correctly for heavily distorted signals.



Function of Rear Speaker

The input signal is connected to the speaker and headphone output for acoustical verification of the test signal.

In the RMS/THD function a special distortion listening mode is installed as follows:

The main frequency component is filtered out by a notch filter, e.g. at using a 100 Hz sinus test signal connected to the XL2 input, this 100 Hz main frequency is filtered by the notch filter, thus the complete frequency spectrum with all noise and harmonics is available at the speaker or headphone output. This special feature allows listening to the actual distortion signal.

Thus e.g. you will hear a noise from the speaker even without any connected inputs signals!

Scope

The scope function visualizes the waveform of the electrical input signal. It automatically triggers to the fundamental frequency and selects the scaling of the X-axis (time) and Y-axis (level) accordingly. The fundamental or most dominant frequency of the input signals is displayed above the scope screen.

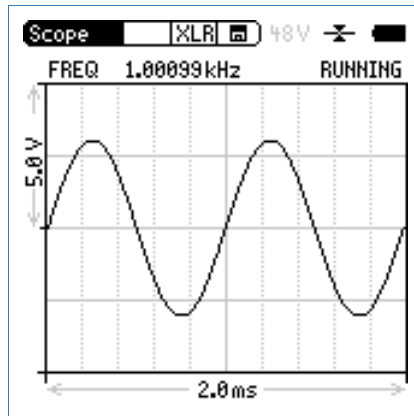

The scope scaling is fixed.

7. Calibration

The XL2 Audio and Acoustic Analyzer meets or exceeds the specifications listed in the chapter “Technical Data”.

Instrument Calibration

In order to maintain the high accuracy annual calibration of the XL2 Analyzer and the measurement microphone is recommended. The calibration service verifies the complete product specifications, differences to the last calibration and measures the frequency response of the measurement microphone. To enquire the calibration service follow the RMA guide lines at www.nti-audio.com/service.

Microphone Sensitivity

The measurement microphones M4260 (class 2) and M2210 (class 1 frequency response) include an electronic data sheet. Thus the automated sensor detection of the XL2 recognizes the sensitivity and calibration data of the connected microphone. The electronic data sheet including the microphone sensitivity is displayed in the menu **Calibrte**.

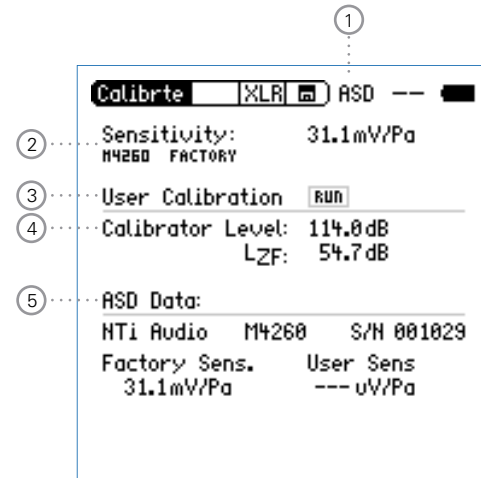

① Phantom Power of Microphone

The XL2 reads the electronic data sheet of the connected microphones M4260 or M2210 and switches the 48 V phantom power automatically on as follows:

- Connect the measurement microphone to the XL2.
- Switch the XL2 on by the on/off button

The **48V** phantom power indication in the upper menu bar changes to **ASD**. The XL2 is ready for acoustical measurements.

② Factory Sensitivity

Factory sensitivity of measurement microphone in mV/Pa. The sensor detection of the XL2 reads the microphone sensitivity automatically using the measurement microphones M4260 or M2210.

③ User Calibration

Sensitivity setting with an external calibrator.

④ Level of External Calibrator



Level setting according the used external calibrator.

⑤ Electronic Data Sheet of Measurement Microphone

Read out data of the connected microphone.

User Calibration - With External Calibrator

User sensitivity setting with an external calibrator of the NTi Audio microphones M4260, M2210 or other microphones.

- Select with the rotary wheel  the parameter **Calibration Level** ④ and press the enter button .
- Set the calibration level according the calibrator used.
- Generate the specific reference signal with the calibrator onto the microphone.
- Select with the rotary wheel  the parameter **RUN** next to





User Calibration ③ and press the enter button .

- The pop-up window **Calibration: Calibration running ...** shows up and changes to **Calibration: Successfully finished!** for a successfully completed calibration.
- Note for NTi Audio microphones: The XL2 writes the user sensitivity additionally onto the electronic data sheet of the connected measurement microphone M4260 or M2210, thus all following measurements utilize the user sensitivity automatically.

 The user calibration with an external calibrator is completed.

User Calibration - Manual Sensitivity Setting

In case no external calibrator is available you may set the sensitivity of non-NTi Audio microphones manually according the product specifications as follows:

- Select **Sensitivity** ② with the rotary wheel .
- Press enter  and adjust the sensitivity with the rotary wheel  in 0.1 mV/Pa steps. The setting range 100 μ V/Pa - 9.99 V/Pa is supported.
- Press enter  to confirm the setting.

 The manual user calibration is completed.

8. Documentation of Test Results

The XL2 stores all acquired measurement data including real time information onto the removable Mini-SD card. Additionally wave files can be recorded automatically and individual voice notes added for a complete documentation of the measurement.

Logging of Sound Levels

- Select the **Log** page in the sound level meter function.
- Set the logging parameters as described in chapter “Logging”
- Press the page button  to return to the numeric result page.
- Carry out the measurement following the described guideline in chapter “Sound Level Meter - Getting Started”.

The XL2 may log the following data simultaneously to the Mini-SD card:

- 005L_SLM.TXT - Selected sound level meter results
- 005L_RTT.TXT - RTA spectra
- 005AUDIO.WAV - Wav-file, ADPCM compressed

The file number automatically incremental for each measurement.

Transfer Measurement Data to PC

- Connect the XL2 with the USB cable to the PC.
- 👉 The PC recognizes the XL2 as mass storage device.
- The following Mini-SD card content is shown:

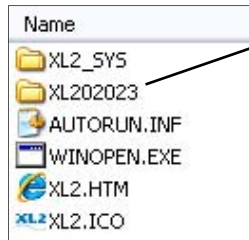

Individual serial number of XL2
e.g. XL2 with S/N 02023.
This folder contains the stored data.

- 👉 The measurement results are stored in individual folders named by the date (format = year-month-day).

- Copy/paste the data files to PC.



Alternatively the Mini-SD card can be inserted into a card reader. This offers a faster data transfer from the Mini-SD card to PC

Log File Format

File name e.g. = 005L_SLM.TXT

XL2 Broadband Logging

Configuration

Start: 2009-08-25, 16:28:14
 End: 2009-08-25, 16:28:30
 Timer mode: continuous
 Timer set: ---:---
 Log-Interval: 00:00:01
 k1: 0.0 dB
 k2: 0.0 dB
 kset Date: 2009-08-25, 10:58
 Mic Sensitivity: 35.7 mV/Pa
 Mic Type: unknown (no ASD)

Broadband LOG Results

Date	Time	Timer	LAeq_dt	LAeq	LCPeak_dt	LAFmax_dt	LAFmin_dt
[YYYY-MM-DD]	[hh:mm:ss]	[hh:mm:ss]	[dB]	[dB]	[dB]	[dB]	[dB]
25.08.2009	16:28:15	00:00:01	71.1	71.1	89.8	72.4	69.8
25.08.2009	16:28:16	00:00:02	72.3	71.7	90.0	73.8	71.0
25.08.2009	16:28:17	00:00:03	71.5	71.6	90.6	72.7	70.1
25.08.2009	16:28:18	00:00:04	71.1	71.5	91.6	73.1	68.5
25.08.2009	16:28:19	00:00:05	71.8	71.6	91.3	73.1	68.4
25.08.2009	16:28:20	00:00:06	71.3	71.5	90.3	71.9	69.6
25.08.2009	16:28:21	00:00:07	71.9	71.6	91.1	73.5	70.0
25.08.2009	16:28:22	00:00:08	71.7	71.6	91.7	73.0	69.1
25.08.2009	16:28:23	00:00:09	71.0	71.5	90.5	73.1	69.5
25.08.2009	16:28:24	00:00:10	72.2	71.6	91.5	73.7	70.0
25.08.2009	16:28:25	00:00:11	71.0	71.6	89.6	72.4	69.3
25.08.2009	16:28:26	00:00:12	71.4	71.5	90.2	73.0	69.2
25.08.2009	16:28:27	00:00:13	72.0	71.6	91.0	72.9	69.3
25.08.2009	16:28:28	00:00:14	71.5	71.6	89.6	72.2	69.8
25.08.2009	16:28:29	00:00:15	71.7	71.6	91.5	74.0	69.9
25.08.2009	16:28:30	00:00:15	71.7	71.6	92.4	72.7	69.1

Broadband LOG Results over whole log period

25.08.2009	16:28:30	00:00:15	71.6	71.6	92.4	74	68.4
------------	----------	----------	------	------	------	----	------



The generated txt-files can be directly opened on the PC for documentation with e.g. Microsoft Excel.

Generate Measurement Report

After any completed measurement a data report can be generated including real time information and all selected results.

- Complete any measurement.
- Select the Mini-SD card symbol in the upper menu bar with the rotary wheel .
- Press the enter button .
- Select **Report** with the rotary wheel and confirm with enter .

A data report of the measurement has been generated. It includes the measurement results of the selected wide-band levels and the real time spectrum.

Report File Format

File name e.g. = 006R_SLM.TXT

```

XL2 Sound Level Meter Reporting
-----
# Configuration
Start:      2009-08-31, 15:27:42
End:        2009-08-31, 15:28:43
Timer mode: continuous
Timer set:  ---:--:
k1:         33.6 dB
k2:         33.4 dB
kset Date:  2009-08-30, 20:43
Mic Sensitivity 20.0 mV/Pa
Mic Type:   unknown (no ASD)

# Broadband Results
LAeq       64.9 dB
LCPeak     97.6 dB
LAFmax     75.6 dB
LAFmin     45.6 dB

# RTA Results

```

Band	LZFmax	LZFmin	LZeq
[Hz]	[dB]	[dB]	[dB]
6.3	44.3	20.2	36.2
8.0	44.3	16.8	36.4
10.0	45.9	17.1	37.8
12.5	52.2	23.0	43.7
16.0	55.3	25.6	47.6
20.0	58.8	25.1	50.5
25.0	61.5	32.2	53.6
31.5	66.5	32.8	57.2
40.0	70.7	35.1	61.5
50.0	75.0	37.7	65.2
63.0	75.1	37.3	64.6
80.0	74.9	35.9	64.2
100.0	75.0	34.1	63.8
125.0	78.4	35.9	64.7
160.0	68.3	41.2	58.9
200.0	79.4	43.3	67.5
250.0	70.9	36.8	59.4
315.0	72.5	35.5	61.1
400.0	70.6	34.9	59.1
500.0	71.9	31.8	59.4
630.0	64.9	29.0	53.3
800.0	65.1	27.2	52.4
1000.0	61.4	28.1	49.2
1250.0	62.7	27.7	50.8
1600.0	61.1	28.0	48.8

9. Microphones

The plug-on measurement microphones M4260 or M2210 form together with the XL2 a comprehensive sound level meter and acoustic analyzer. The microphones are 48 VDC phantom powered and include an electronic data sheet.

Integrated Preamplifier

The microphone bodies contain the pre-amplifier and require 48 VDC phantom power supply for operation. They combine high dynamic range and wide frequency range with low noise. The measurement microphones can also be connected with the ASD Cable to the XL2 Audio and Acoustic Analyzer for measurements at remote locations or reducing acoustical reflections.

Electronic Data Sheet

The M4260 and M2210 measurement microphones include an electronic data sheet. The automated sensor detection (ASD) of the XL2 Analyzer reads this data sheet, enabling the XL2 to automatically recognize the microphone model, sensitivity and calibration data. This ensures correct measurement results using the M4260 or M2210 microphones.

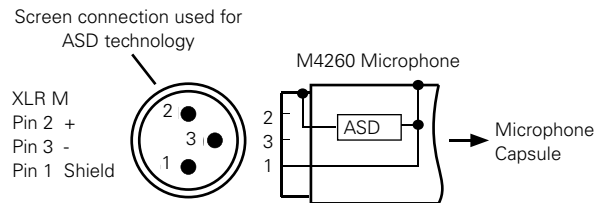

Connection Diagram of Measurement Microphones
M4260 and M2210 - Enhanced Performance

Microphone plugs directly to the XL2

The XL2 automatically reads ASD electronic data sheet of the connected microphone as follows:

- Connect the measurement microphone to the XL2.
- Switch on the XL2 with the on/off button .

 The XL2 reads the electronic data sheet of the connected microphone during a short initialization process prior the first measurement.

Microphone Connection via the ASD Cable

The measurement microphones M4260 and M2210 can be connected with the ASD Cable to the XL2 Audio and Acoustic Analyzer for measurements at remote locations or reducing acoustical reflections. The ASD Cable includes a separate line for transmitting the electronic data sheet to the XL2, thus not affecting the measurement data.

The electronic data sheet is transmitted via the XLR connector's housing and the shield lead of the ASD Cable. Do not touch these parts during the short initialization period to ensure the complete data sheet is recognized by the XL2. The automated sensor detection does not disturb any measurements. You may chain up to 4x ASD Cables together in tandem. The ASD technology supports accurate data communication up to a length of 20 meters (= 65 feet).

Microphone Connection via a professional Audio Cable

For distances longer than 20 meter (= 65 feet) use a high quality, low capacitance standard professional audio cable. In this scenario, no separate data line for the transmission of the electronic data sheet is available, thus the microphone sensitivity has to be entered manually into the XL2 Analyzer.



- Use the microphone for the intended purpose only.
- Protect the microphone from contamination by always using the supplied windscreen.
- Never use the microphone in a damp or wet environment.
- Do not jar or drop the microphone.
- Do not remove the microphone protective grid.
- Do not touch the microphone membrane.
- Remove the white dust cap of the M2210 measurement microphone prior to use.

10. Further Information

Tips and Trouble Shooting

Resetting to Factory Default

If the XL2 Audio and Acoustic Analyzer reacts unexpectedly, a reset to the factory settings might solve the problem.

- Switch the XL2 off.
- Hold down the escape button  and simultaneously operate the On/Off button .

 The reset confirmation is displayed.

XL2 Starts Up with Limited Functions

The XL2 has been operated the last time in one of the simplified application profiles and the system settings have been changed as follows: **Select Profile** from **Yes** to **No**.

- Follow the above resetting to factory default.

 The XL2 will start up with full functions.

Mini-SD Card Errors

The XL2 Audio and Acoustic Analyzer writes measurement data automatically onto the Mini-SD card during ongoing measurements, thus a working Mini-SD card has to be inserted at any time.

Error Messages	Actions to do
Missing SD-Card	Insert the Mini-SD card.
SD-Card is not FAT formatted	Format the Mini-SD card on the PC.
SD-Card is full	The memory of the Mini-SD card is full, thus download all data to PC and empty the Mini-SD card.

Can I use another Mini-SD Card ?

Yes, you can use any alternative Mini-SD card.

- Switch the XL2 off.
- Insert the Mini-SD card into the XL2 Analyzer.
- Switch the XL2 on.

 The XL2 writes the data structure automatically on the inserted Mini-SD card.

Firmware Update of XL2

You will find information about the installed firmware version in the systems settings of your instrument. The firmware revision history is listed on our web site: <http://support.nti-audio.com/XL2>.

Updating the firmware on the XL2 is executed by a XL2Vxxx.xx file which is first placed in the root directory of the XL2. When started, the XL2 automatically completes the firmware update. There are multiple ways to carry out the firmware update:

XL2 in hand, PC online with activated auto start function:

- Connect the XL2 to the PC by the USB cable.
- The auto start pop-up “NTi Audio XL2” appears, select “Open the XL2 Instrument Status”.
- The web screen “XL2 Instrument Status” opens, select “Look for FW Update”.
- The web screen “XL2 Support Page” opens.
- Download the firmware file into the Mini-SD card.
- Remove the USB cable and power up the XL2.
- Watch the display and wait until the update is finished.

PC online without auto start function:

- Remove the XL2 from the PC.
- Open the web site:
<http://support.nti-audio.com/xl2/index.php>
- The web screen “XL2 Support Page” opens.
- Download the firmware XL2Vxxx.xx.
- Load the firmware file XL2Vxxx.xx into the Mini-SD card.
- Insert the Mini-SD card.
- Power up the XL2.
- Watch the display and wait until the update is finished.

No PC available:

If you have no web access at all, please contact your local NTi Audio partner. You will receive the new firmware file by e-mail.

Options

The following options extend the features of the XL2:

- Speech Intelligibility STI-PA NTi Audio #: 600 000 038

The STI-PA function measures the speech intelligibility of public announcement systems according the latest revision of IEC 60268-16:2003 standard. The XL2 displays the measurement results as STI or as CIS results, accompanied by the individual levels and modulation indices of the seven octave bands. The measurement results are acquired from the dedicated STI-PA test signal, generated by the

- included Test Signal CD
- Minirator MR-PRO, test signal generator, required for audio systems with line inputs
- NTi Audio TalkBox, acoustic signal generator, required for audio systems with voice microphones, thus measuring the complete signal chain

- Extended Acoustic Pack NTi Audio #: 600 000 039

The Extended Acoustic Pack offers the following additional features for sound level- and acoustical measurements.

- Percentiles: 1%, 5%, 10%, 50%, 90%, 95%, 99%
- Time weighting: Impulse
- Sound Pressure Levels L_{1eq} , Sound Exposure Level L_{AE}
- TaktMax and values as specified in DIN 45645-1
- Digital I/O interface
- Recording of WAV-files (24 bit, 48 kHz)
- High-resolution Zoom-FFT with selectable frequency ranges and resolution up to 0.4 Hz in the range of 5 Hz to 20 kHz

Accessories



Ever-ready Pouch

The Ever-ready Pouch protects the XL2 during transport and operation. With its convenient belt-clip, the XL2 can be kept close by for those tasks requiring both hands. The Ever-ready Pouch allows operation of the XL2 fitted in the pouch.

NTi Audio #: 600 000 335



Mains Power Adapter

Mains Power Adapter for XL2 Audio and Acoustic Analyzer. Non original power supplies may cause interferences with the measurement.

NTi Audio #: 600 000 333

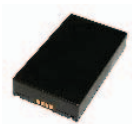

Spare Li-Po Battery

Have a rechargeable spare battery available for portable measurements at any time.

NTi Audio #: 600 000 337



Battery Charger

The Battery Charger contains a sophisticated battery charge controller for efficient charging of the spare Li-Po battery. The battery charger includes 1x spare Li-Po battery.

NTi Audio #: 600 000 332



ASD Cable

The ASD Cable allows for extended connections of the measurement microphones M4260 or M2210, while maintaining the automated sensor detection functionality (ASD). You may chain up to 4x ASD Cables together in tandem.

Length = 5 meter (16 feet)

NTi Audio #: 600 000 336



Exel System Case

This compact system case provides the professional transport protection for work in the field. It offers space for the handheld instruments, cables and connectors.

NTi Audio #: 600 000 334



Calibration Certificate

Individual calibration certificate with serial number according to the standards EN ISO / IEC 17025.

NTi Audio #: 600 000 018



Precision Calibrator

The calibrator ensures accurate sound level measurements. The class 1 sound calibrator provides 114 dB SPL @ 1 kHz for calibration of measurement microphones.

NTi Audio #: 640 300 101



Microphone Stand Adapter XL2

Mechanical adapter piece to mount the XL2 on a microphone stand.

NTi Audio #: 600 000 372



Minirator MR-PRO

The MR-PRO is an extremely powerful analog audio generator to satisfy every need for the professional engineer. It generates the following analog audio signals:

- Sine Waveforms, freely selectable frequencies and levels up to +18 dBu
- Sweep Signals, any frequency interval up to 1/12 octave
- White Noise, Pink Noise
- Polarity Test Signal
- Delay Test Signal
- Wave Files (*.wav)

NTi Audio #: 600 000 310



NTi Audio TalkBox

The NTi Audio TalkBox greatly simplifies the acoustical feed of the STI-PA intelligibility test source signal into closed sound reinforcement systems. It presents the standardized voice-like acoustical signal emission simulating a human talker according to IEC 60268-16, combined with a TNO certified speech intelligibility signal at standardized levels.

NTi Audio #: 600 000 085

Warranty Conditions

International warranty

NTi Audio guarantees the function of the XL2 Audio and Acoustic Analyzer and the individual components for a period of one year from the date of sale. During this period, defective instruments will either be repaired free of charge or replaced.

Limitations



These guarantee provisions do not cover damage caused by accidents, transportation, incorrect use, carelessness, accessories or the installation of any parts that were not delivered with the instrument, the loss of parts, connection to the mains voltage, operation with non-specified input voltages, adapter types or incorrectly inserted batteries. In particular, NTi Audio accepts no responsibility for subsequent damage of any kind. The warranty will be voided by the carrying out of repairs or service work by third parties who are not part of an approved NTi Audio Service Centre.

Repairs

In the case of faulty functioning or damage, send the instrument in its original packaging with prepaid shipping, insured for your full value, to the local NTi Audio agency in your country. Please enclose a precise description of the fault along with your full contact information.

You can find the contact addresses on the NTi Audio web site www.nti-audio.com.

Repair work will only be carried out under warranty upon presenting the original sales receipt.

	<p>Damage through impacts / shocks</p> <ul style="list-style-type: none">• The protective shock jacket shields your instrument against reasonable impacts that could occur in normal use.• Do not intentionally subject the instrument to extreme stress!• Please do not drop the instrument!• Damage caused by dropping or impact is not covered by warranty.
	<p>Damage by moisture</p> <p>Do not use the instrument in damp environments! The instrument can be permanently damaged by the penetration of water.</p>

Declaration of Conformity

CE / FCC Compliance Statement

We, the manufacturer
 NTi Audio AG
 Im alten Riet 102
 9494 Schaan
 Liechtenstein, Europe

do hereby declare that the XL2, M4260 and M2210, approved in 2009, comply with the following standards or other standard documents:

EMC: 89/336, 92/31, 93/68
 Harmonized standards: EN 61326-1

This declaration will become invalid if modifications to the instrument are carried out without the written approval of NTi Audio.

Date: 1. September 2009

Signature:



Position: Technical Director



Information for Disposal and Recycling

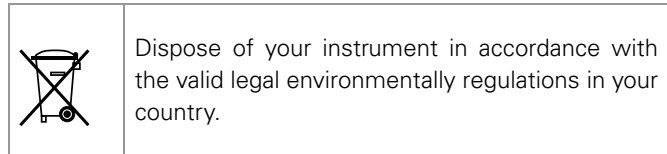

Regulations for the European Union and other European countries with corresponding laws:

The instrument must not be disposed of in the household garbage. At the end of its service life, bring the instrument to a collecting point for electrical recycling in accordance with the legal regulations.

Other countries outside the European Union:

Contact your respective authorities for the valid environmental regulations in your country.

11. Technical Data XL2

Sound Level Meter	
Product Configurations	<ul style="list-style-type: none"> • XL2 with M2210 microphone: Class 1 frequency response acc. to IEC 61672 • XL2 with M4260 microphone: Class 2 acc. to IEC 61672
Conforms with Standards	IEC 61672, IEC 60651, IEC 60804, ANSI S1.4, ANSI S1.43, DIN 15905-5, DIN 45645-2, SLV 2007, optional: DIN 45645-1
Measurements	<ul style="list-style-type: none"> • SPL actual, L_{eq}, L_{min}, L_{max}, L_{Cpeak} • Gliding L_{Aeq} with $t = 5', 10', 15'$ and $60'$ • All measurement results are simultaneously available • Correction value measurement wizard • Logging all data or subsets in selectable intervals • Recording of WAV-files (ADPCM) and voice notes • Limit monitoring showing exceeding sound levels • Level resolution: 0.1 dB • Internal noise: 1.3 μV A-Weighted
Functions Extended Acoustic Pack (optional)	<ul style="list-style-type: none"> • Percentiles: 1%, 5%, 10%, 50%, 90%, 95%, 99% • Time weighting: Impulse • Sound Pressure Level L_{Leq} • Sound Exposure Level L_{AE} • TaktMax and values as specified in DIN 45645-1 • Digital I/O interface • Recording of WAV-files (24 bit, 48 kHz) • High-resolution FFT, up to 0.4 Hz resolution in the range of 5 Hz - 20 kHz

Weighting	<ul style="list-style-type: none"> • Frequency Weighting: A, C, Z • Time Weighting: Fast, Slow, optional: Impulse
Real Time Analyzer RTA	<ul style="list-style-type: none"> • Frequency resolution: 1/3 octave, 1/1 octave, wide band • Frequency range: 6.3 Hz to 20 kHz, level resolution: 0.1 dB • Band pass filters conform IEC 61260 class 0, ANSI S1.11-2004, class 1
Acoustic Analyzer	
FFT Analysis	<ul style="list-style-type: none"> • Real time FFT with LZf and L_{eq} • Level resolution: 0.1 dB • Ranges: 7 Hz - 215 Hz, 58 Hz - 1.72 kHz, 484 Hz - 20.5 kHz • Optional: High-resolution FFT in the range of 5 Hz - 20 kHz
Reverberation Time RT60	<ul style="list-style-type: none"> • 1/1 octave bands results from 63 Hz - 8 kHz, based on T_{20} • 1/3 octave bands results by post processing • Range: 10 ms - 14 seconds • Measurement according to ISO3382 by Schroeder-method • Test signal: Impulse source or gated pink noise generated by the MR-PRO, MR2 or the included NTi Audio Test CD

Delay Time	<ul style="list-style-type: none"> • Propagation delay between electrical reference signal and acoustical signal using the internal microphone • Range: 0 ms - 1 second (0 m - 344 m) • Resolution: 0.1 ms • Test signal: NTi Audio delay test signal generated by the MR-PRO, MR2 or the included NTi Audio Test CD
Polarity	<ul style="list-style-type: none"> • Checks polarity of speakers and line signals • Positive/Negative detection of wideband and individual 1/1 octave bands through internal microphone or XLR/RCA connector • Test signal: NTi Audio polarity test signal generated by the MR-PRO, MR2 or the included NTi Audio Test CD
STI-PA Speech Intelligibility (optional)	<ul style="list-style-type: none"> • Single value STI and CIS test result according to IEC 60268-16, 2003 release, DIN VDE 0833-4, IEC 60849, DIN VDE 0828-1 • Modulation indices and individual band level results with error indicator, post processing with recorded spectra supported • Test signal: NTi Audio STI-PA signal generated by the MR-PRO, NTi Audio TalkBox or the STI-PA Test CD

Audio Analyzer	
Level RMS	<ul style="list-style-type: none"> • True RMS detection in V, dBu and dBV • Range XLR/RCA input: 2 μV - 25 V (-112 dBu to +30 dBu) • Accuracy: \pm 0.5 % @ 1 kHz, flatness: \pm 0.1 dB • Bandwidth: 20 Hz to 20 kHz • Resolution: 3 digits (dB scale), 5 digits (linear scale) or 6 digits (x1 scale)
Frequency	<ul style="list-style-type: none"> • Range: 9 Hz to 20 kHz, resolution: 6 digits • Accuracy: $<$ \pm 0.003%
THD+N (Total Harmonic Distortion + Noise)	<ul style="list-style-type: none"> • Range: -100 dB to 0 dB (0.001% to 100%) • Minimum level: $>$ -90 dBu • Bandwidth: 10 Hz to 20 kHz • Resolution: 3 digits (dB scale) or 4 digits (linear scale) • Residual THD+N @ XLR/RCA input: $<$ 2 μV
Scope	Auto ranging, auto scaling
Filter	Frequency weighting: A, C, Z, Highpass 400 Hz, Highpass 19 kHz

Input / Output Interfaces	
Audio Inputs	<ul style="list-style-type: none"> • XLR balanced with input impedance = 200 kOhm, phantom power: +48 V switchable, automated sensor detection for M4260/M2210 • RCA unbalanced with input impedance >30 kOhm • Built-in condenser microphone for polarity testing, delay measurements and voice note recording
Audio Outputs	<ul style="list-style-type: none"> • Built-in speaker • Headphone connector 3.5 mm Minijack Stereo
USB Interface	USB mini connector for data transfer to PC and charging of Li-Po battery
Digital I/O	Optional 1-wire interface for control of external peripherals
TOSLink	24 bit linear PCM audio signal output (prepared for later firmware extension)
Memory	Mini-SD card, 2 GByte, removable, storing ASCII data, screenshots, voice notes and Wav-files
Power Supply	<ul style="list-style-type: none"> • Rechargeable Li-Po battery included, type 3.7 V / 2260 mAh, typical battery lifetime > 4 hours • Dry cell batteries type AA, 4 x 1.5 V, typical battery lifetime > 4 hours • Linear external power supply 9 VDC (charges Li-Po battery in operation)

General	
Clock	Real time clock with lithium backup battery
Calibration	<ul style="list-style-type: none"> • Recommended calibration interval: one year • Microphone calibration supported with external calibrator • Calibration certificate for new instruments optional available
Mechanics	<ul style="list-style-type: none"> • Tripod mount and wire stand mounted on rear side • Display: 160 x 160 pixels grey scale with LED back light • Dimensions: 180 mm x 90 mm x 45 mm (7.1" x 3.5" x 1.8") • Weight: 480 g (1 lbs) including built-in Li-Po battery
Temperature	Operation: +5 °C to +45 °C (41° - 113°F) Storage: -10 °C to +60 °C (14° - 140°F)
Humidity	5% to 90% RH, non condensing
Electromagnetic Compatibility	CE compliant: EN 61326-1 Class B, EN 55011 class B, EN 61000-4-2 to -6 & -11

12. Technical Data Microphones

	M4260	M2210 - Enhanced Performance
Microphone Type	Omni-directional, pre-polarized condenser, free field microphone	
Capsule / Transducer	1/4" permanently installed capsule	1/2" detachable capsule with 60UNS2 thread
Flatness	Class 2 (IEC61672-1)	Class 1 (IEC61672-1)
Frequency Range	20 Hz - 20 kHz	1 Hz - 20 kHz
Residual Noise Floor typical	29 dB(A)	19 dB(A)
Linear measurement range with XL2 acc. IEC 60804	35 dB(A) - 136 dB	24 dB(A) - 144 dB
Maximum SPL @ THD 3%, 1 kHz	136 dB	144 dB
Sensitivity typical	-30 dBV/Pa \pm 4 dB (30 mV/Pa) @ 1kHz	-34 dBV/Pa \pm 3 dB (20 mV/Pa) @ 1kHz
Temperature coefficient	0.05 dB / °C @ +10 to +50°C	0.01 dB / °C @ -10 to +50°C
Electronic Data Sheet	NTi Audio ASD according IEEE P1451.4 V1.0, Class 2, Template 27	
Output Impedance	100 Ohm balanced	
Power Supply	48 VDC phantom power, 3 mA typical	
Dimensions	Length 150 mm (5.9"), diameter 20.5 mm (0.8")	
Connector	Balanced 3-pole XLR	

o M4260 Measurement Microphone

S/N =

Sensitivity =

mV/Pa

o M2210 - Enhanced Performance Measurement Microphone

Appendix

Appendix 1: Standard - Extended Features

	Standard Features	Extended Acoustic Pack
Sound Level Meter Frequency Weighting	A C Z	
Sound Level Meter Time weighting	F S EQ EQ_T PK	I Impulse E Sound Exposure Level Percentile Sound Pressure Levels: 1% 5% 10% 50% 90% 95% 99%

Sound Level Meter Parameter	<input type="checkbox"/> live <input checked="" type="checkbox"/> max <input type="checkbox"/> min	Taktmaximalpegel according to DIN 45645-1: <input checked="" type="checkbox"/> T3 <input type="checkbox"/> T3eq <input type="checkbox"/> T5 <input type="checkbox"/> T5eq Calculated levels according to DIN 45645-1: LAFT5eq-LAeq LAIeq-LAeq LCeq-LAeq
Sound Level Meter Correction	<input checked="" type="checkbox"/> K1 <input checked="" type="checkbox"/> K2 <input type="checkbox"/> off	
Sound Level Meter Audio Recording	<ul style="list-style-type: none"> • Recording of WAV-files (ADPCM) • Voice note recording 	<ul style="list-style-type: none"> • Recording of WAV-files (24 bit, 48 kHz)
FFT Analysis Measurement Range	<input checked="" type="checkbox"/> 200 <input type="checkbox"/> 1k7 <input type="checkbox"/> 20k	<input checked="" type="checkbox"/> usr

Appendix 2: Application Profiles

The XL2 may start up with individual preset application profiles.



Full XL2 Functions **FULL** XL2 MODE

All sound level meter functions are available as listed in Appendix 1: Standard Features.

Basic Sound Level Meter **BASIC** SLH MODE

Includes the basic sound level meter settings for monitoring of live events or environmental noise. The following sound pressure levels can be displayed:

L_{AF} L_{AF} , L_{AFmax} , L_{AFmin}
with or without correction value $k1$

L_{AS} L_{AS} , L_{ASmax} , L_{ASmin}
with or without correction value $k1$

L_{Aeq} L_{Aeq} with or without correction value $k1$



L_{Cpeak} L_{Cpeak} with or without correction value $k2$

In the real time analyzer page all sound level meter functions are available as listed in Appendix 1: Standard Features.

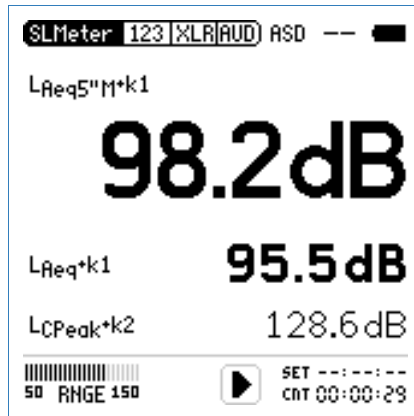
Sound Level Monitoring according to DIN15905

DIN15905
 GERMANY

How to measure:

- Select the page **KSET** with the rotary wheel .
- Measure the correction values k1 and k2 as described in the chapter "Correction Value KSET".
- Press the start button .
- During the measurement flashes the indication **AUD**.
- Press stop  to finish the measurement.



All sound pressure levels according DIN15905 are measured, displayed and logged to Mini-SD card automatically. The recording of ADPCM compressed wav-files is activated. The settings are locked ensuring the required parameters are measured.

These levels are shown in the numeric result page:

- LAeq5" M+k1 Moving time-averaged integrated sound pressure level LAeq with 5 seconds time interval and correction value k1.
- LAeq+k1 Time-averaged integrated sound pressure level LAeq with correction value k1
- LCpeak+k2 C-weighted peak level LCpeak with correction value k2

The limit button indicates sound pressure levels exceeding the standardized limits, thus allowing to take immediate actions against the high levels.

Green Color $L_{Aeq5''M+k1} < 95 \text{ dB}$

Yellow Color $95 \text{ dB} < L_{Aeq5''M+k1} < 99 \text{ dB}$

Red Color $99 \text{ dB} < L_{Aeq5''M+k1}$

The following sound levels are displayed in the real time analyzer page:

L_{ZFhold} For tracing of feedback frequencies. The peak hold time can be set to 3, 5 or 10 seconds.

L_{ZFlive} Actual real time spectra.

Sound Level Monitoring according to SLV 2007

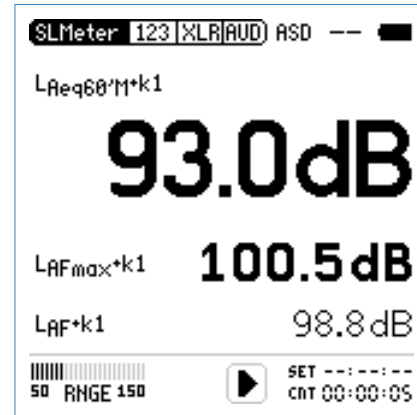

How to measure:

- Select the page KSET with the rotary wheel .
- Measure the correction values $k1$ and $k2$ as described in the chapter "Correction Value KSET".
- Press the start button .
- During the measurement flashes the indication **AUD**.
- Press stop to finish the measurement.



All sound pressure levels according SLV 2007 are measured, displayed and logged to Mini-SD card automatically. The recording of ADPCM compressed wav-files is activated. The settings are locked.

These levels are shown in the numeric result page:

$L_{Aeq60'M+k1}$	Moving time-averaged integrated sound pressure level with 60 minutes moving time interval and correction value $k1$.
$L_{AFmax+k1}$	Maximum sound pressure level L_{AFmax} with correction value $k1$
L_{AF}	Actual sound pressure level with A-weighting

The limit button indicates sound pressure levels exceeding the standardized limits.

Green Color	$L_{Aeq60'M+k1} < 96 \text{ dB}$
Yellow Color	$96 \text{ dB} < L_{Aeq60'M+k1} < 100 \text{ dB}$
Red Color	$100 \text{ dB} < L_{Aeq60'M+k1}$

The following sound levels are displayed in the real time analyzer page:

L_{ZFhold}	For tracing of feedback frequencies. The peak hold time can be set to 3, 5 or 10 seconds.
L_{ZFlive}	Actual real time spectra.

Appendix 3: Description Sound Levels



A-Frequency Weighting Filter acc. to IEC 61672

Applicable for most common sound pressure level measurement following the human hearing perception at lower sound pressure levels.



C-Frequency Weighting Filter acc. to IEC 61672

Applicable for very high sound pressure levels following the human hearing perception at high sound pressure levels; typically used for measurements of peak values e.g. L_{Cpeak}



Sound Exposure Level

Energy of the A-weighted sound pressure level during the measurement time in dB as e.g. applicable according the standard IEC 61252, "Measurement of Exposure to Noise in the Workplace". For a time interval of 1 second is $L_{AE} = L_{Aeq}$.



Time-Average Sound Level or Equivalent Continuous Sound Level according to IEC 61672



Moving Time-Average Sound Level or Moving Equivalent Continuous Sound Level

with selectable time intervals of 5 seconds, 10 minutes, 15 minutes or 60 minutes. The moving time-average sound level is a L_{eq} based on a moving time window.

Sample:

10h 00min 00sec	Start of XL2 measurement
10h 00min 05sec	$L_{eq5''}$ = L_{eq} of this 5 seconds
10h 00min 06sec	$L_{eq5''}$ = L_{eq} of the time window from 10h 00min 01sec to 10h 00min 06sec
10h 00min 07sec	$L_{eq5''}$ = L_{eq} of the time window from 10h 00min 02sec to 10h 00min 07sec

Application example:

- Display the moving L_{eq} over 5 seconds according to DIN15905
- Measure the moving L_{eq} over 60 minutes according to SLV2007

F**Fast Time Weighting**

Short attack- and release response time, $t = 125$ ms; the time weighting defines how changes of the instantaneous sound pressure level are averaged for useful sound pressure level results. The fast time weighting is commonly used.

Hold**Holding Peak Level**

For tracing of feedback frequencies in the RTA page. The peak hold time can be set to 3, 5 or 10 seconds.

I**Impulse Time Weighting**

Very short attack- and release response time, $t = 35$ ms; the time weighting defines how changes of the instantaneous sound pressure level are averaged for useful sound pressure level results.

K1**Correction Value k1**

Applies for RMS based values (L_{AF} , L_{Aeq} , ...). The correction value k1 is measured or pre-set in the page **KSET** of the sound level meter function.

K2**Correction Value k2**

Applicable at time weighting setting PK (= peak). The correction value k2 is measured or pre-set in the page **KSET** of the sound level meter function.

live**Parameter live**

Actual sound pressure level.

max**Parameter max**

Maximum sound pressure level of the measurement cycle

min**Parameter min**

Minimum sound pressure level of the measurement cycle

off**Correction Value off**

No correction value, default setting

PK**Peak Level**

Application example:

Measure L_{Cpeak} according to DIN15905



Percentile Sound Level - Level Statistics

The sound pressure level exceeding xx% during the measurement period; e.g. $L_{AF90\%}$ is the level exceeded at 90% of the measurement period. The percentile value xx is user defined; available are 1%, 5%, 10%, 50%, 90%, 95%, 99%. The statistical distribution of sound pressure levels is commonly used at background noise analysis.



Slow Time Weighting

Long attack- and release response time, $t = 1$ second; the time weighting defines how changes of the instantaneous sound pressure level are averaged for useful sound pressure level results.



Parameter T3

Taktmaximalpegel L_{AFT3} acc. to DIN 45645-1. Maximum sound pressure level measured with frequency weighting A and time weighting F within a time interval of 3 seconds.



Parameter T3 equivalent

Time-average Taktmaximalpegel L_{AFT3eq} acc. to DIN 45645-1.



Parameter T5

Taktmaximalpegel L_{AFT5} acc. to DIN 45645-1. Maximum sound pressure level measured with frequency weighting A and time weighting F within a time interval of 5 seconds.



Parameter T5 equivalent

Time-average Taktmaximalpegel L_{AFT5eq} acc. to DIN 45645-1.



Z- frequency weighting according to IEC 61672 (= flat frequency response, no filter)

Overall sound pressure level, all sound signal components are included; required for special applications.

Appendix 4: Common Sound Levels

Display	Application	Setting
L_{AE}	<p>Sound Exposure Level</p> <p>Energy of the A-weighted sound pressure level during the measurement time in dB as e.g. applicable according the standard IEC 61252, "Measurement of Exposure to Noise in the Workplace". For a time interval of 1 second is $L_{AE} = L_{Aeq}$.</p>	A -> E
L_{AF}	<p>Actual Sound Pressure Level</p> <p>SPL with A frequency weighting and F time weighting following the human hearing perception at lower sound pressure levels, e.g. applicable at levels lower than 100 dB.</p>	A -> F -> live -> off
L_{Aeq}	<p>Time-Average Sound Level or Equivalent Continuous Sound Level</p> <p>Averaged sound level over time with A frequency weighting.</p>	A -> EQ -> off
$L_{Aeq} + k1$	<p>Time-Average Sound Level with Correction Value</p> <p>The actual measurement position often differs to the loudest position of the live event. Thus the correction value $k1$ is the measured correction value of L_{Aeq} between loudest position and actual measurement position by using pink noise. The correction value $k1$ is measured or pre-set in the page KSET of the sound level meter function.</p>	A -> EQ -> K1

L_{AFmin}	<p>Minimum Sound Pressure Level Measures the minimum environmental noise level during the measurement period.</p>	A -> F -> min
$L_{AFxx\%}$	<p>Percentile Sound Level The sound pressure level exceeding xx% during the measurement period; e.g. $L_{AF90\%}$ is the level exceeded at 90% of the measurement period. The percentile value xx is user defined; available are 1%, 5%, 10%, 50%, 90%, 95%, 99%. The statistical distribution of sound pressure levels is commonly used at background noise analysis.</p>	more -> 90% -> off
L_{Cpeak}	<p>Peak Sound Level Measures the peak sound pressure level with C frequency weighting according IEC 61672; typically required to measure possible short and high peak levels, which may damage the human hearing, such as defined in DIN 15905-5.</p>	C -> PK -> off
$L_{Cpeak} + k2$	<p>Peak Sound Pressure Level with Correction Value The actual measurement position often differs to the loudest position of the live event. Thus the correction value k2 is the measured correction value of L_{Cpeak} between loudest position and actual measurement position by using pink noise. The correction value k2 is measured or pre-set in the page KSET of the sound level meter function.</p>	C -> PK -> k2

L_{AeqxxM}	<p>Moving Time-Average Sound Level</p> <p>Measurement of the moving sound level over time L_{eq} with A frequency weighting and F time weighting; the parameter xx is user defined with the available settings</p> <ul style="list-style-type: none"> • 5 seconds according DIN 15905-5 • 10 minutes according French standard • 15 minutes according British standard • 60 minutes according SLV 2007 	
$L_{Aeq60'M} +k1$	<p>Moving Time-Average Sound Level with Correction Value k1</p> <p>The actual measurement position often differs to the loudest position of the live event. Thus the correction value k1 is the measured correction value of $L_{Aeq60'M}$ between loudest position and actual measurement position by using pink noise. The correction value k1 is measured or pre-set in the page KSET of the sound level meter function.</p> <p>Application: Measurements according SLV 2007</p>	