

**Datasheet**

Art.No. 07.312.7155.0

End plate APFN 2,5 D2/2/35

End plate for DIN rail terminal blocks type WKFN..., color gray



Art.No.	07.312.7155.0
EAN	4015573715868
Order unit	10 pieces

**Approvals**

**Technical data**

**General**

Colour	Grey
Type of end plate	Yes
Type of partition	No
Thickness	1.5 mm
Snap in	Yes
Inflammability class of insulation material acc. with UL94	V0

**Accessories**

Type of end plate	Yes
Type of partition	No
Colour	Grey
Thickness	1.5 mm
Snap in	Yes
Inflammability class of insulation material acc. with UL94	V0

These dimensions will be especially checked at delivery  
 Only inspection dimensions  
 With /E marked dimensions are only valid for internal use

Diese Maße werden bei Abnahme besonders geprüft  
 Ausschließlich Prüfmaße  
 Mit /E gekennzeichnete Maße sind nur für interne Zwecke gültig

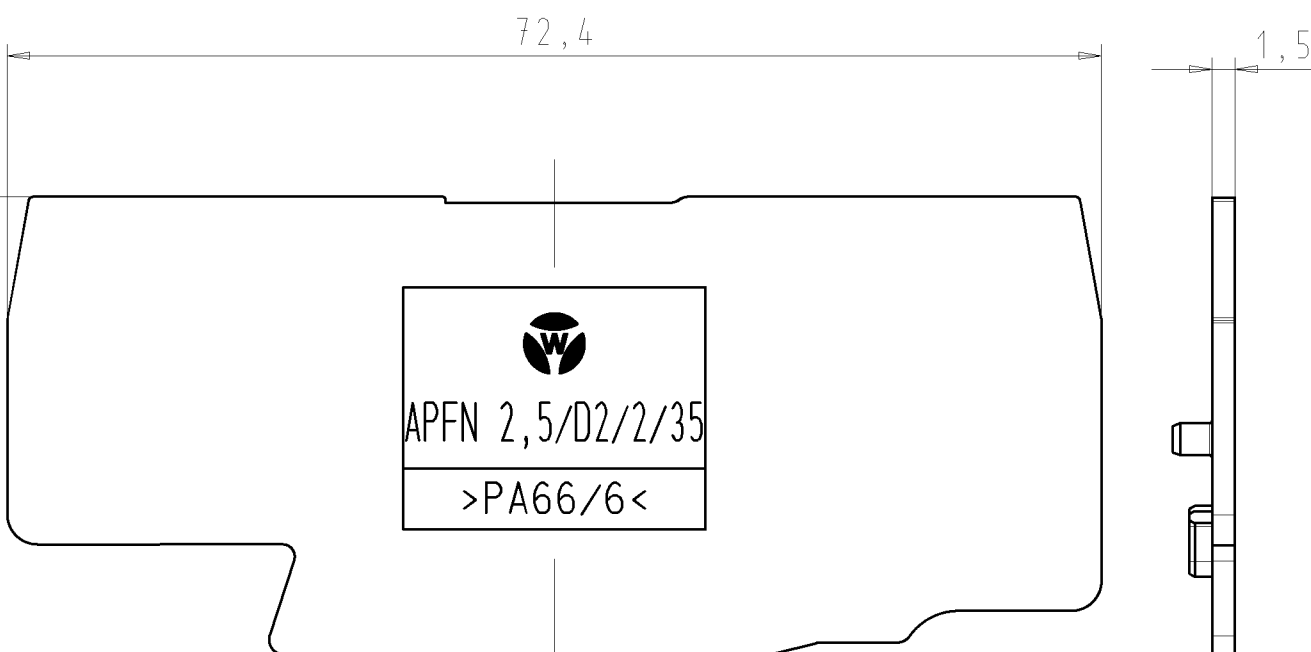

Weitere Daten siehe Katalog  
 further data see catalog

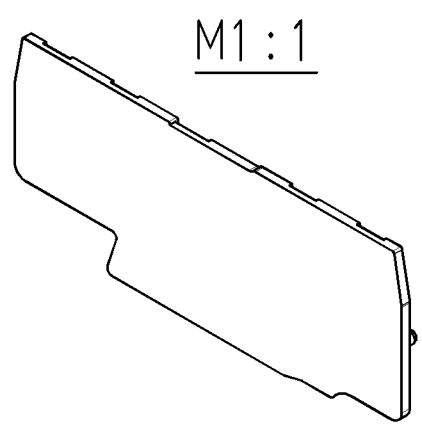

Teile-Nr./part-no.	Farbe/colour	Typ/type
07.312.7155.0	grau/grey	APFN 2,5/D2/2/35
07.312.7155.1	schwarz/black	APFN 2,5/D2/2/35 SW
07.312.7155.2	weiß/white	APFN 2,5/D2/2/35 WS
07.312.7155.6	blau/blue	APFN 2,5/D2/2/35 BLAU
07.312.7155.7	grün/green	APFN 2,5/D2/2/35 GRÜN
07.312.7155.9	orange	APFN 2,5/D2/2/35 OR

Tolerierung nach DIN 7167/Tolerance system acc. to DIN 7167. ja/yes  Stoffverbots- und Deklarationsliste nach UU-TQM-05/03 ist einzuhalten. (This DIN-standard describes the envelope principle. According to the envelope principle the deviations of form and parallelism are limited by the size tolerances). Conformity with Wieland document UU-TQM-05/03 (list of prohibited / declarable hazardous substances) to be declared!

Freitoleranz nach - CAD - Zeichnung, keine manuellen Änderungen 1.Verwendung: - Blatt: 1 von 1  
 General tolerance CAD - drawing, no manual modifications allowed First Use: Sheet: 1 of 1

	/		Werkstoff/Material	2004	Tag/Date	Name	Zeichnung Nr./Drawing No.	Index
	/			gezeichnet drawn	19.03.	Schmitt J.		
	/			geprüft checked	-	-		
	/			Normgepr. Stand., check	-	-		
	/	Maßstab/Scale					Maße in mm/Dimensions are in mm	
	/	2:1						
	/	Vol.	mm³	Ofl./Surf.	mm²	Ersatz für/Replacement for: -		

b	17.07.2013/		<b>wieland</b> Elektrische Verbindungen	Type	Benennung/Title	
a	22.01.2008/			<b>ABSCHLUSSPLATTE</b> fasis PRO end plate		
Index	Datum / Blatt Date / Sheet					
Änderung/Revision						

1 2 3 4 5 6 7 8 9 10 11 12 13 14 15 16 17 18 19 20 M1 M2 M3 L G i 11.1 12.1 1.1  
 073127155001K\_1 CADW3070 U0016728 2013-07-17 11:40:26 1.000  
 QU-PEM-08/91