

MDL 0300 24; MDLB 0300 24

Alimentatore Switching + gestione batteria 27,4V 3,0A
Switching Mode Power Supply + Battery Management 27.4V 3.0A

***** Suitable for 12V, 7Ah Lead-acid Rechargeable Batteries (connected in series)*****

The model MDLB 0300 24 is provided with two 12V 7Ah batteries (connected in series)

Codice documento – Document Code: **CE0280_Ed1A**

Edizione – Issue: **1st Edition rev.A (10-03-2009)**

Versioni precedenti – Previous versions:
1st Edition (15-01-2008)

DOC: CE0280_Ed1A

DATE: 2009-03-16

**CONTROLLED IF
STAMPED IN RED
QUALITY DEPARTMENT**

Scritto – Written: **Ing. Fabio Batocchi**
Approvato – Approved: **Ing. Fabio Batocchi**

***** All technical specifications are subjected to change without notice! *****

All parts included in this documentation are property of **COMATEC snc**. All rights reserved. This document and its information (or part of its) can't be reproduced or used without an explicit written permission.

MDL 0300 24
MDLB 0300 24

DATA – DATE:
10-03-2009
EDIZIONE – ISSUE:
1st Ed. Rev.A

DESCRIPTION

The Equipment is divided in two main stages:

- Switching Mode Power Supply (SMPS),
- Battery Management (BM).

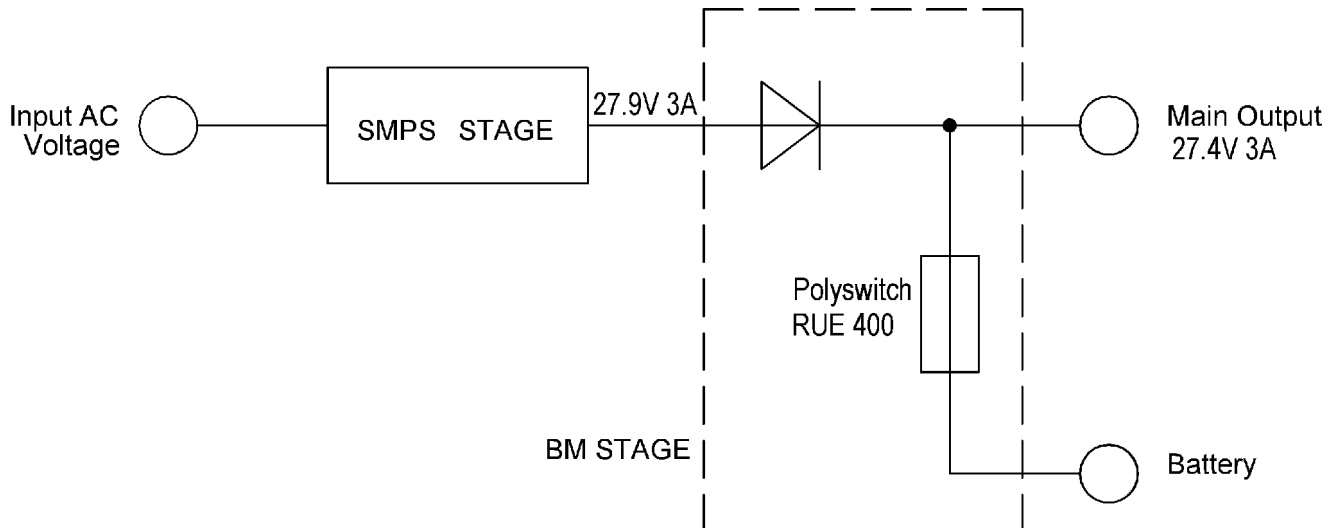

Picture n.1: Equipment Blocks Diagram

The SMPS stage is a switching mode power supply having one main output: 27.9V 3A.

We used a quasi-resonant flyback converter that improve emissions behaviour and efficiency.

The output regulation is obtained by a voltage and current regulator ic, placed in the primary side. It can control both the Output Voltage and the Maximum Current Control Loops. For $I_{out} < I_{max}$ the Voltage Loop gets priority; if the supply operates in the over-current protection mode, the Current Loop is active and reduces the output voltage with constant output power P_{max} (up to short-circuit).

The BM stage is a simple passive network that connect the battery to the main output, during the power-fail operation mode (using a polyswitch).

During the normal operation, a diode connects the SMPS stage to the output (obtaining 27.4V 3A) and to the battery (charging it with a two-step algorithm).

The equipment is suitable for 12V 7Ah lead-acid rechargeable batteries (two connected in series).

During the normal operation, the battery is charged using a two-step algorithm:

- (1) Constant current = the current is constant and the voltage rises slowly up to 27.4V. The current value depends by the battery internal impedance and the load on the main output. For NO-load conditions on the main output and a battery full discharged, the current may reach about 3A.
- (2) Constant voltage = the voltage is constant to 27.4V and the current falls slowly up to few mA.



CARATTERISTICHE ELETTRICHE

Electrical Specifications

CODICE – CODE:
CE0280

FOGLIO - SHEET:
3 of 12

During the power-fail condition, the battery supplies the main output. The over-current protection is assured by a PolySwitch (RUE 400).

LED SIGNALLING

The equipment provides following complex signalling.

MODO DI FUNZIONAMENTO <i>Operation Mode</i>	LED 1 <i>Led 1</i>	LED2 <i>Led 2</i>
Tensione di rete presente – <i>Main supply present</i>	Verde – <i>Green</i>	X
Tensione di rete e uscita presenti – <i>Main supply and outpu present</i>	Verde – <i>Green</i>	Verde – <i>Green</i>
Tensione di rete assente e uscita presente <i>Main supply absent and output present</i>	Spento – <i>OFF</i>	Rosso – <i>Red</i>
Uscita assente – <i>Output absent</i>	X	Spento – <i>OFF</i>
Sovraccarico d'uscita – <i>Output overload</i>	Rosso – <i>Red</i>	Spento – <i>OFF</i>

All parts included in this documentation are property of **COMATEC snc**. All rights reserved. This document and its information (or part of its) can't be reproduced or used without an explicit written permission.

MDL 0300 24
MDLB 0300 24

DATA – DATE:
10-03-2009

EDIZIONE – ISSUE:
1st Ed. Rev.A



CARATTERISTICHE ELETTRICHE

Electrical Specifications

CODICE – CODE:
CE0280FOGLIO - SHEET:
4 of 12

STADIO SMPS: CARATTERISTICHE D'INGRESSO *SMPS Stage: Input Requirements*

Tamb=25°C; fin=50Hz, se non specificato altrimenti		Tamb=25°C; fin=50Hz, unless otherwise specified				
N°	PARAMETRO <i>Parameter</i>	CONDIZIONI <i>Conditions</i>	MIN	TYP	MAX	UNITA' <i>Unit</i>
1	Input Voltage Range		195	230	254	Vrms
2	Input Frequency Range		48		63	Hz
3	Input Current	Vin=195Vrms; Iout=3A (full load) Vin=195Vrms; Iout= NO load		0.03	0.98	Arms Arms
4	Inrush Current	Vin = 265Vrms; full load		25		Apk
5	Power Factor	Vin=195-254Vrms; full load	0.45		0.50	
6	Efficiency	Vin=230Vrms; full load		85		%

Note 1: The range of source voltage for which the power supply is guaranteed to meet its specifications.

Note 2: The range of source frequency for which the power supply is guaranteed to meet its specifications.

Note 3: The maximum value of the steady state AC input current, measured for any combination of rated AC voltage and environment and for any combination of rated continuous output loading (up to a maximum of Watts).

Note 4: The high surge of input current that occurs upon initial turn-on, after an OFF period of at least 10 seconds.

Note 5: The ratio of actual power used in a circuit to apparent power, for any combination of AC input voltage. Power factor is the measure of the fraction of current in phase with the voltage and contributing to average power.

Note 6: The ratio of output power to input power, measured at full load and for any combination of the rated AC input voltage.

All parts included in this documentation are property of **COMATEC snc**. All rights reserved. This document and its information (or part of its) can't be reproduced or used without an explicit written permission.

MDL 0300 24
MDLB 0300 24

DATA – DATE:
10-03-2009EDIZIONE – ISSUE:
1st Ed. Rev.A

STADIO SMPS: CARATTERISTICHE D'USCITA *SMPS Stage: Output Requirements*

Tamb=25°C; fin=50Hz, se non specificato altrimenti		Tamb=25°C; fin=50Hz, unless otherwise specified				
N°	PARAMETRO <i>Parameter</i>	CONDIZIONI <i>Conditions</i>	MIN	TYP	MAX	UNITA' <i>Unit</i>
1	Output Voltage	Vin = 230Vrms; half load	27.4 +/- 3%			Vdc
2	Output Current Range		0		3	Adc
3	Rated Output Power			82		W
4	Line Regulation	Half load		+/- 0.01		%
5	Load Regulation	Vin = 230Vrms		+/- 1.0		%
6	Output Ripple - line component - switching component	Tamb = 0 – 40°C Vin = 195 Vrms; full load Vin = 230 Vrms; full load			30 30	mVpp mVpp
7	PARD	Vin=230Vrms; full load		60		mVpp
8	Set-up Time					
9	Hold-up Time					
10	Rise Time					
11	Fall Time					
12	Repetitive Dynamic Load	Vin = 230Vrms		450		mVpp

Note 1: The DC voltage measured at the output terminal blocks, for any combination of rated AC voltage, environment and AC input frequency.

Note 2: Output current limits within that the power supply is in regulation (see point 1).

Note 3: The maximum steady-state power which the equipment is guaranteed to be able to deliver, while continuing to meet its other specifications.

Note 4: Amount of change in the DC output voltage (expressed in percentage of output voltage) as the input voltage is varied over its specified range. The parameter is usually measured at half load.

Note 5: Amount of change in the DC output voltage (expressed in percentage of output voltage) as the output load is varied over its specified range. The parameter is usually measured at rated input voltage

Note 6: Unwanted portion of output voltage harmonically related in frequency to the input line and to any internally generated switching frequency.

Ripple is measured with a 100nF ceramic capacitor in parallel with a 47uF electrolytic capacitor connected between the measured voltage and its return. Usually, it is used a differential measure system with 20MHz bandwidth.

Note 7: Measures all disturbances (superimposed to output voltage), including the spikes, high frequency voltage peaks caused, among others, by steep switching slopes. PARD is measured with a 100nF ceramic capacitor in parallel with a 47uF electrolytic capacitor connected between the measured voltage and its return. Usually, it is used a differential measure system with 20MHz bandwidth.

Note 8: Time duration from power supply turn-on until its output voltage goes up into a regulated limit ($V_{out} = V_{nom} - 3\%$).

Note 9: Time duration from power supply turn-off until its output voltage goes down into an unregulated limit ($V_{out} = V_{nom} - 3\%$).

Note 10: Time measured (during turn-on transition) between 10% and 90% of the rated output voltage.

Note 11: Time measured (during turn-off transition) between 90% and 10% of rated output voltage.

Note 12: Output voltage ripple (expressed in mVpp) measured when the output is dynamically loaded as follows: 0.25Imax to 0.75Imax to 0.25Imax (slew rate = 3.2mV/us, duration = 100ms).

All parts included in this documentation are property of **COMATEC snc**. All rights reserved. This document and its information (or part of its) can't be reproduced or used without an explicit written permission.

MDL 0300 24
MDLB 0300 24

DATA – DATE:
10-03-2009

EDIZIONE – ISSUE:
1st Ed. Rev.A

CONDIZIONI AMBIENTALI *Environment Conditions*

N°	PARAMETRO <i>Parameter</i>	CONDIZIONI <i>Conditions</i>	MIN	TYP	MAX	UNITA' <i>Unit</i>
1	Operating Temperature Range	Vin=195-254Vrms; full load	0		+40	°C
2	Storage Temperature Range		-40		+80	°C
3	Operating Humidity Range	Vin=195-254Vrms; full load	0		95	%
4	Storage Humidity Range		0		95	%
5	Cooling	Natural convection, no fan required				
6	Acoustic	The equipment doesn't produce audible noise				

AFFIDABILITA', SICUREZZA E COMPATIBILITA' ELETTROMAGNETICA
Reliability, Safety and Electromagnetic Compatibility

N°	PARAMETRO <i>Parameter</i>	CONDIZIONI <i>Conditions</i>	VALUE	UNITA' <i>Unit</i>
1	Life of capacitors	Vin=230Vrms; half load; Tamb = 30°C	100000	h
2	SAFETY Protection Index Withstand Voltage Insulation Resistance Leakage Current	Primary / Secondary (60 seconds) Primary / Secondary	EN60950-1 IP20 3000 > 4 < 250	Vrms Mohm uA
3	EMI		EN55022/B	
4	EMS		EN55024	
5	EMC		EN61000-3-2 EN61000-3-3	

Note 1: The life of Aluminium Electrolytic Capacitors is calculated by the following formula (Law of 10°C, doubling). The life shall be a double of the calculation result. However, it shall be 1.5 times of the calculation result for capacitors with 10mm diameter or less.

$$L_n = L_o * 2^{(T - T_n)/10}$$

where:

L_n = estimated life hours at the ambient temperature of 30°C

L_o = life hours of maximum guaranteed temperature T

T = maximum guaranteed temperature of capacitor

T_n = the case temperature of capacitor (30°C converted)

Note 3: Conducted & Radiated Emissions Requirements

Note 4: Immunity Characteristics

Note 5: Electromagnetic Compatibility. Limits for harmonic current emissions and limitation of voltage fluctuations & flicker

All parts included in this documentation are property of **COMATEC snc**. All rights reserved. This document and its information (or part of its) can't be reproduced or used without an explicit written permission.

MDL 0300 24
MDLB 0300 24

DATA - DATE:
10-03-2009

EDIZIONE - ISSUE:
1st Ed. Rev.A

STADIO SMPS: MECCANISMI DI PROTEZIONE *SMPS Stage: Protection Mechanisms*

Tamb=25°C; fin=50Hz, se non specificato altrimenti		<i>Tamb=25°C; fin=50Hz, unless otherwise specified</i>				
N°	PARAMETRO <i>Parameter</i>	CONDIZIONI <i>Conditions</i>	MIN	TYP	MAX	UNITA' <i>Unit</i>
1	Input Under Voltage	Full load			100	Vrms
2	Input Over-Current	By Fuse		T 1.6		Arms
3	Input Inrush Current	By NTC resistor		25		Apk
4	Output Current Limiting	Vin = 195 Vrms		3.50		Adc
		Vin = 230 Vrms		3.70		Adc
		Vin = 254 Vrms		3.75		Adc
5	Maximum Output Power					
6	Output Over-current		LEAN-FORWARD MODE			
7	Output Short-circuit (10 mOhm)	Vin = 195-254 Vrms	3.90 (note 10)			Adc
8	OV and open-loop		BURST MODE			
9	High Temperature					

Note 1: The device shall shutdown without latch-off if the input voltage goes down the specified limit.

Note 2: The device has an internal over-current protection. A delayed-blow, high breaking capacity fuse (not accessible) is placed in the line side of the input circuit.

Note 3: The device has an internal inrush current protection. A NTC resistor (not accessible) is placed in the line side of the input circuit.

Note 4: Maximum steady-state output current obtainable from the regulated output.

Note 5: Maximum steady-state output power obtainable from the two regulated outputs (12V + battery).

Note 6: The device shall not be damaged when input power is applied with an output over-current. During this condition the device produces a "LEAN FORWARD MODE" working.

Note 7: The device shall not be damaged when input power is applied with an output short circuit (less than 0.1 ohm). During this condition the device produces an "LEAN FORWARD MODE" working.

Note 8: The device shall shutdown without latch-off the output and go into the burst mode operation. During burst mode the output voltage pulses with peak value of about 33V.

Note 9: When the junction temperature reaches specified value the controller IC shall shutdown and protects other components from failure. The temperature protection is not latching; after an over-temperature shutdown, the controller will restart as temperature drops.

Note 10: Output current of the SMPS Stage. Must be added the battery current, limited by the RUE400 PolySwitch.

LEAN FORWARD MODE = the equipment permits the current to be increased by a factor 1.2 of the maximum rated value, and slowly reduces the output voltage (up to 0 volts, during short-circuit). This increased current is permanently available, so that the device neither switches-off nor hiccups as a result of overload or short-circuiting.

DISEGNI MECCANICI *Mechanical Drawings*



MODUSV: Top view

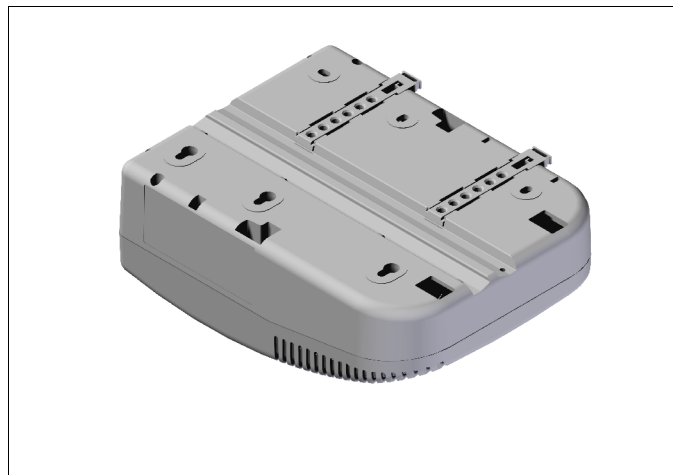

MODUSV: Bottom view

*Additional Battery pack**MODUSV + additional battery pack*

**CARATTERISTICHE ELETTRICHE***Electrical Specifications*

CODICE - CODE:

CE0280

FOGLIO - SHEET:

11 of 12**MATERIALE PLASTICO DEL CASE** *Plastic Material of the case***ASYBLEND R.7035 (or equivalent)**

CARICO SNERVAMENTO A TRAZIONE - <i>Tensile Strength at Yield</i>	58 - 62 MPa
ALLUNGAMENTO A ROTTURA (50mm/min) - <i>Extensibility</i>	45 - 55 %
MODULO ELASTICO A TRAZIONE - <i>Tensile Modulus</i>	2.3 - 2.5 GPa
COSTANTE DIELETTRICA - <i>Dielectric Constant</i>	3.1
PESO SPECIFICO - <i>Specific Gravity</i>	1.19 gr/cm ³
ASSORBIMENTO ACQUA - <i>Water Absorption</i>	0.4 - 0.5 %
FLUIDITA' (MFI) - <i>Melt Flow Index</i>	23 - 25 gr/10min
TEMP. DI INFLESSIONE (HDT) A 0.46 MPa - <i>Deflection Temp. Under load</i>	120 - 130 °C
TEMP. DI RAMMOLLIMENTO (VICAT) - <i>Softening Temperature</i>	115 - 125 °C
RESISTENZA ALLA FIAMMA - <i>Flame Resistant</i>	UL94-V0

All parts included in this documentation are property of **COMATEC snc**. All rights reserved. This document and its information (or part of its) can't be reproduced or used without an explicit written permission.

MDL 0300 24
MDLB 0300 24

DATA - DATE:

10-03-2009

EDIZIONE - ISSUE:

1st Ed. Rev.A

ETICHETTE *Labels*

MATERIALE - Material: 3M, polyester mod. 7818

LABEL N.1

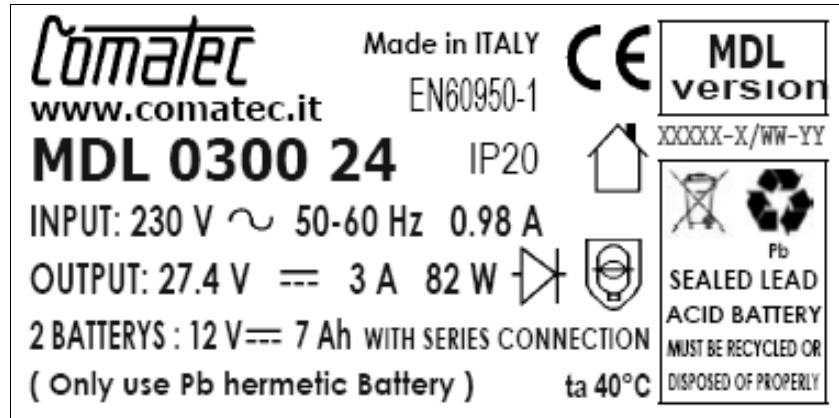

Comatec Made in ITALY **CE** **MDL version**
 www.comatec.it EN60950-1
MDL 0300 24 IP20
 INPUT: 230 V ~ 50-60 Hz 0.98 A
 OUTPUT: 27.4 V = 3 A 82 W
 2 BATTERYS : 12 V = 7 Ah WITH SERIES CONNECTION
 (Only use Pb hermetic Battery) ta 40°C

XXXXX-X/WW-YY
 SEALED LEAD ACID BATTERY
 MUST BE RECYCLED OR DISPOSED OF PROPERLY

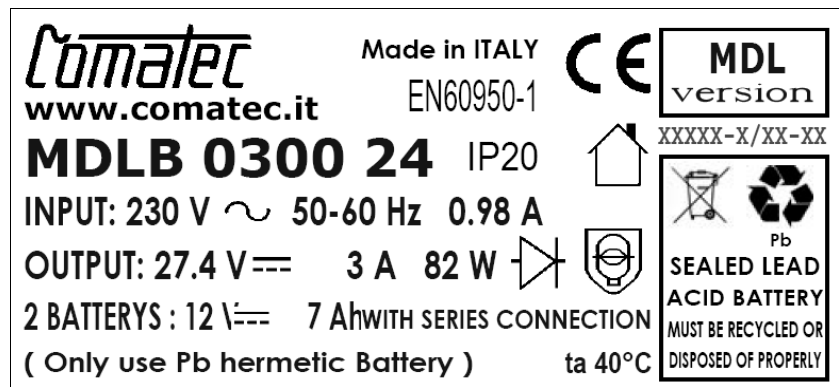

Comatec Made in ITALY **CE** **MDL version**
 www.comatec.it EN60950-1
MDLB 0300 24 IP20
 INPUT: 230 V ~ 50-60 Hz 0.98 A
 OUTPUT: 27.4 V = 3 A 82 W
 2 BATTERYS : 12 V = 7 Ah WITH SERIES CONNECTION
 (Only use Pb hermetic Battery) ta 40°C

XXXXX-X/XX-XX
 SEALED LEAD ACID BATTERY
 MUST BE RECYCLED OR DISPOSED OF PROPERLY

LABEL N.2

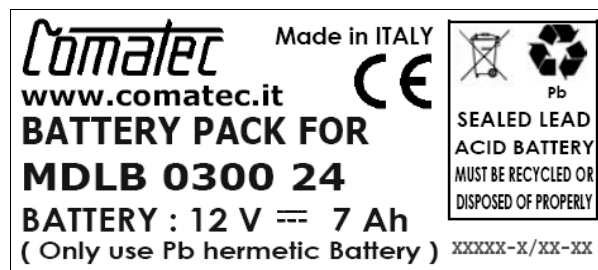

Comatec Made in ITALY **CE**
 www.comatec.it
BATTERY PACK FOR
MDLB 0300 24
BATTERY : 12 V = 7 Ah
 (Only use Pb hermetic Battery)

SEALED LEAD ACID BATTERY
 MUST BE RECYCLED OR DISPOSED OF PROPERLY
 XXXXX-X/XX-XX

 All parts included in this documentation are property of **COMATEC snc**. All rights reserved. This document and its information (or part of its) can't be reproduced or used without an explicit written permission.

MDL 0300 24
MDLB 0300 24

 DATA - DATE:
10-03-2009

 EDIZIONE - ISSUE:
1st Ed. Rev.A