

# Model Selection

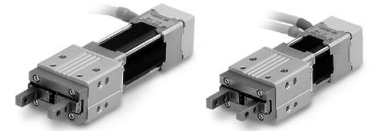

## Selection Procedure

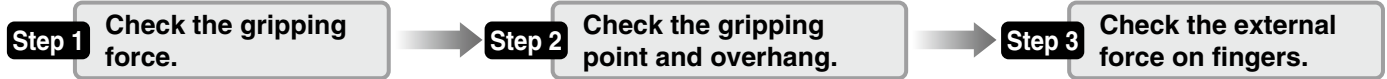

### Step 1 Check the gripping force.

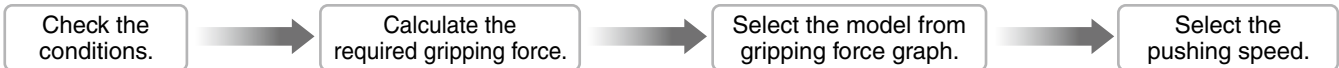

#### Example

Workpiece mass: 0.1 kg

**Guidelines for the selection of the gripper with respect to workpiece mass**

- Although conditions differ according to the workpiece shape and the coefficient of friction between the attachments and the workpiece, select a model that can provide a gripping force of 10 to 20 times <sup>Note)</sup> the workpiece weight, or more.

Note) For details, refer to the calculation of required gripping force.

- If high acceleration or impact forces are encountered during motion, a further margin of safety should be considered.

Example) When it is desired to set the gripping force at 20 times or more above the workpiece weight.  
 Required gripping force  
 = 0.1 kg x 20 x 9.8 m/s<sup>2</sup> ≈ 19.6 N or more

#### LEHZ20

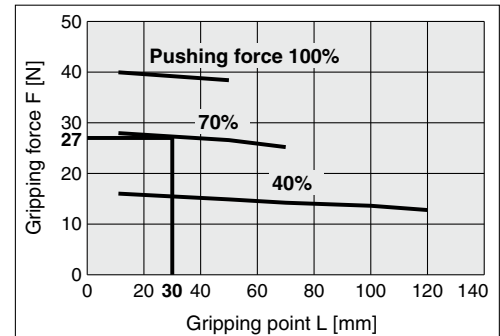

#### When the LEHZ20 is selected.

- A gripping force of 27 N is obtained from the intersection point of gripping point distance L = 30 mm and pushing force of 70%.
- Gripping force is 27.6 times greater than the workpiece weight, and therefore satisfies a gripping force setting value of 20 times or more.

Pushing force: 70%

Pushing force is one of the values of step data that is input into the controller.

Gripping point distance: 30 mm

Pushing speed: 30 mm/sec

#### LEHZ20

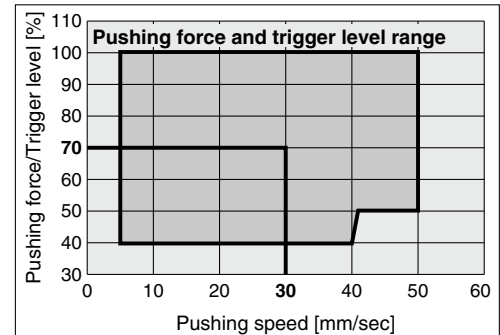

- Pushing speed is satisfied at the point where 70% of the pushing force and 30 mm/sec of the pushing speed cross.

Note) Confirm the pushing speed range from the determined pushing force [%].

### Calculation of required gripping force

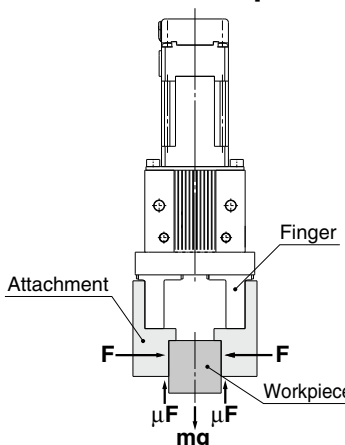

When gripping a workpiece as in the figure to the left, and with the following definitions,  
**F**: Gripping force (N)  
**μ**: Coefficient of friction between the attachments and the workpiece  
**m**: Workpiece mass (kg)  
**g**: Gravitational acceleration (= 9.8 m/s<sup>2</sup>)  
**mg**: Workpiece weight (N)

the conditions under which the workpiece will not drop are  
 $2 \times \mu F > mg$

Number of fingers

and therefore,  $F > \frac{mg}{2 \times \mu}$

With "a" representing the margin, "F" is determined by the following formula:

$$F = \frac{mg}{2 \times \mu} \times a$$

#### "Gripping force at least 10 to 20 times the workpiece weight"

The "10 to 20 times or more of the workpiece weight" recommended by SMC is calculated with a margin of "a" = 4, which allows for impacts that occur during normal transportation, etc.

When $\mu = 0.2$	When $\mu = 0.1$
$F = \frac{mg}{2 \times 0.2} \times 4 = 10 \times mg$	$F = \frac{mg}{2 \times 0.1} \times 4 = 20 \times mg$
↑ 10 x Workpiece weight	↑ 20 x Workpiece weight

<Reference> Coefficient of friction  $\mu$  (depends on the operating environment, contact pressure, etc.)

Coefficient of friction $\mu$	Attachment – Material of workpieces (guideline)
0.1	Metal (surface roughness Rz3.2 or less)
0.2	Metal
0.2 or more	Rubber, Resin, etc.

- Note) • Even in cases where the coefficient of friction is greater than  $\mu = 0.2$ , for reasons of safety, select a gripping force which is at least 10 to 20 times greater than the workpiece weight, as recommended by SMC.  
 • If high acceleration or impact forces are encountered during motion, a further margin should be considered.

**Selection Procedure**

**Step 1 Check the gripping force: Series LEHZ**

● **Indication of gripping force**

The gripping force shown in the graphs below is expressed as "F", which is the gripping force of one finger, when both fingers and attachments are in full contact with the workpiece as shown in the figure below.

● Set the workpiece gripping point "L" so that it is within the range shown in the figure below.

**External Gripping State**

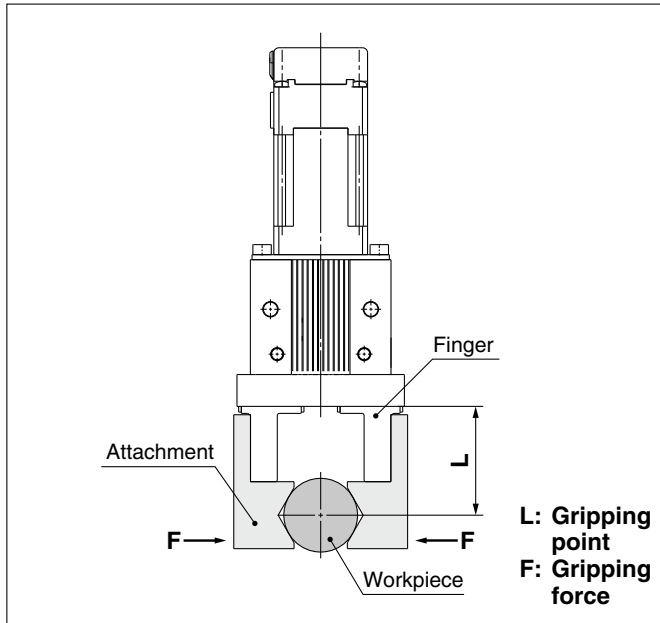

**Internal Gripping State**

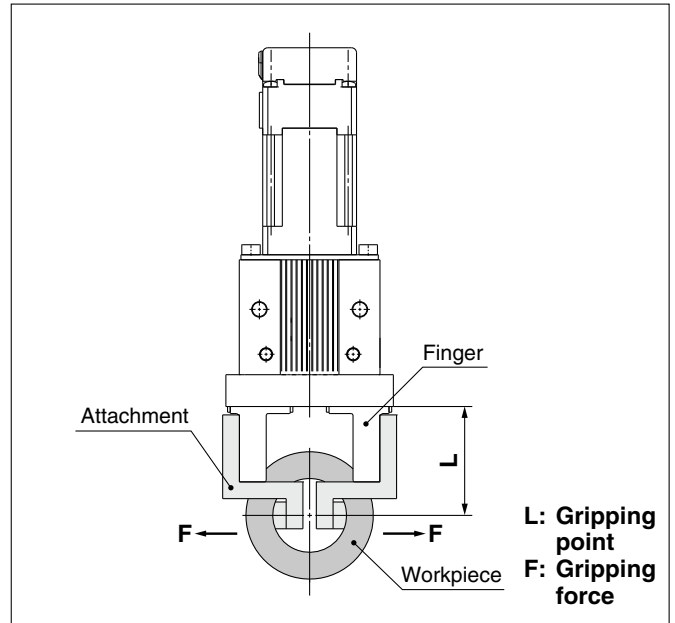

**Basic**

\* Pushing force is one of the values of step data that is input into the controller.

**LEHZ10**

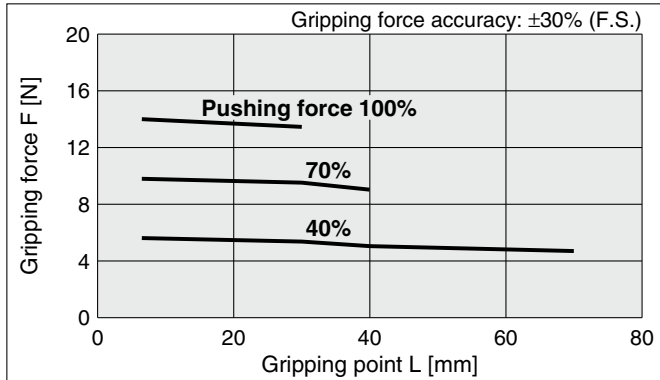

**LEHZ16**

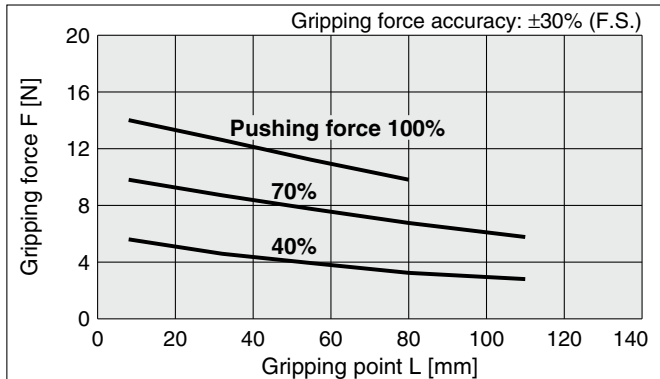

**Compact**

\* Pushing force is one of the values of step data that is input into the controller.

**LEHZ10L**

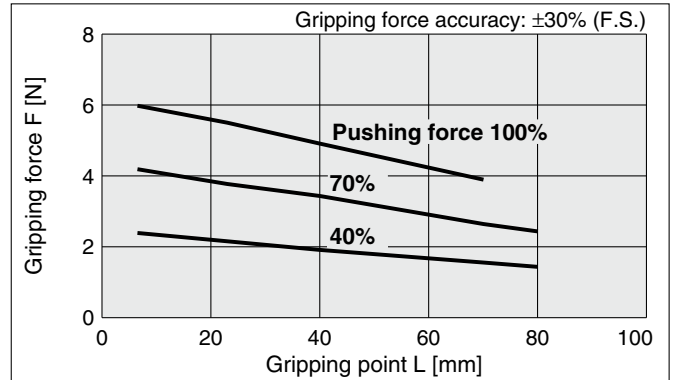

**LEHZ16L**

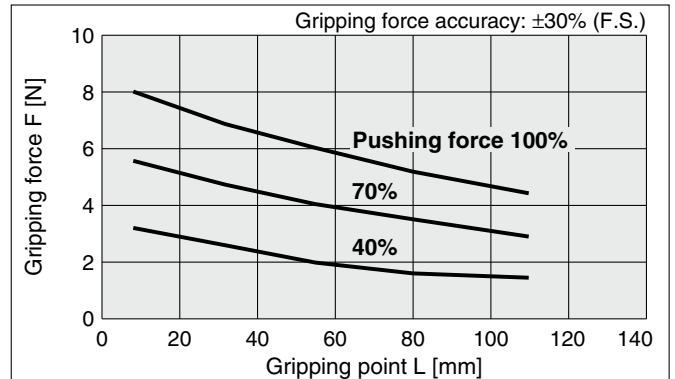

Model Selection

LEHZ

LEHZJ

LEHF

LEHS

LECP6

LEC-G

LECP1

LECPA

Specific Product Precautions

# Series LEHZ

## Selection Procedure

### Step 1 Check the gripping force: Series LEHZ

#### Basic

\* Pushing force is one of the values of step data that is input into the controller.

##### LEHZ20

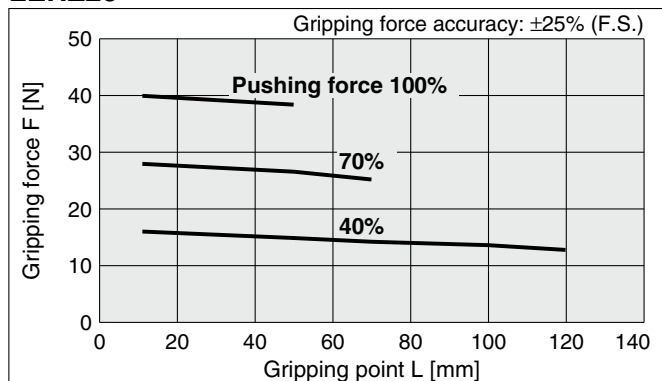

##### LEHZ25

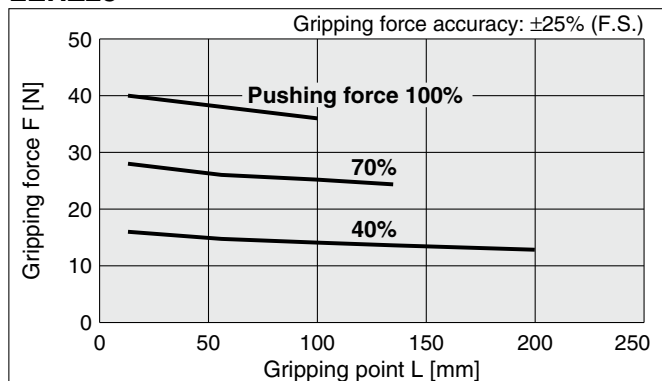

##### LEHZ32

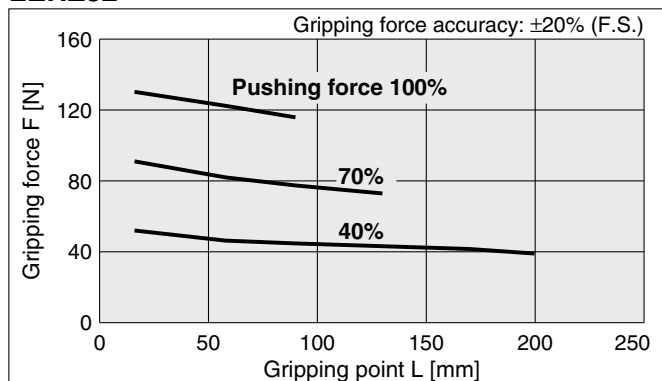

##### LEHZ40

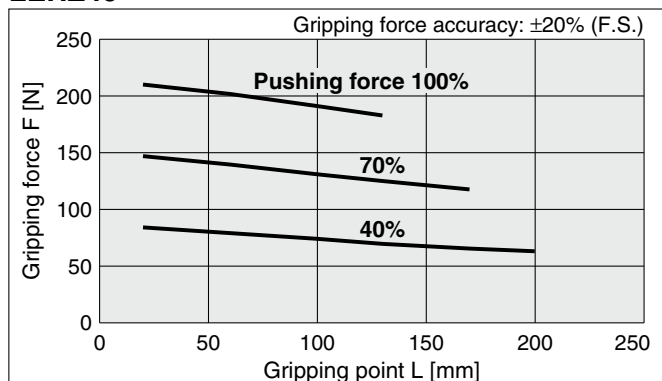

#### Compact

\* Pushing force is one of the values of step data that is input into the controller.

##### LEHZ20L

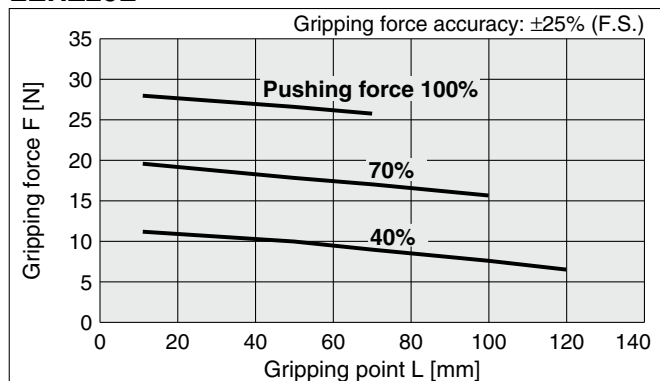

##### LEHZ25L

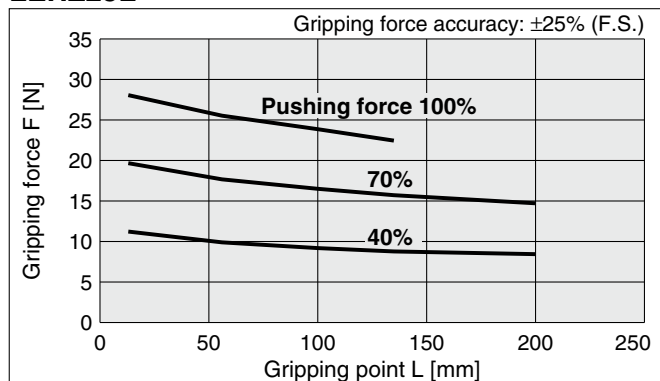

### Selection of Pushing Speed

● Set the [Pushing force] and the [Trigger LV] within the range shown in the figure below.

#### Basic



#### Compact

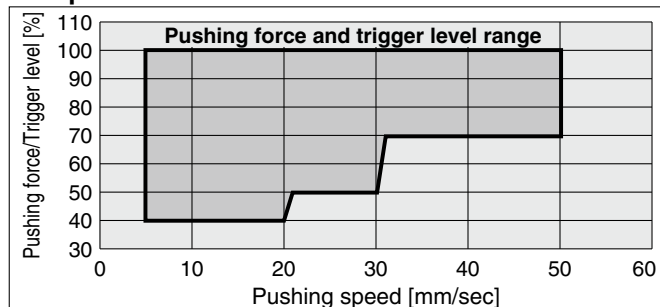

## Step 2 Check the gripping point and overhang: Series LEHZ

- Decide the gripping position of the workpiece so that the amount of overhang "H" stays within the range shown in the figure below.
- If the gripping position is out of the limit, it may shorten the life of the electric gripper.

**External Gripping State**

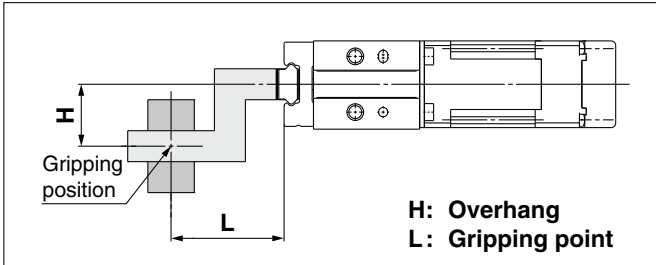

**Internal Gripping State**

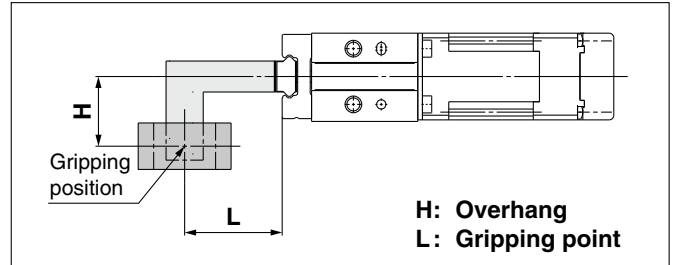

### Basic

\* Pushing force is one of the values of step data that is input into the controller.

#### LEHZ10

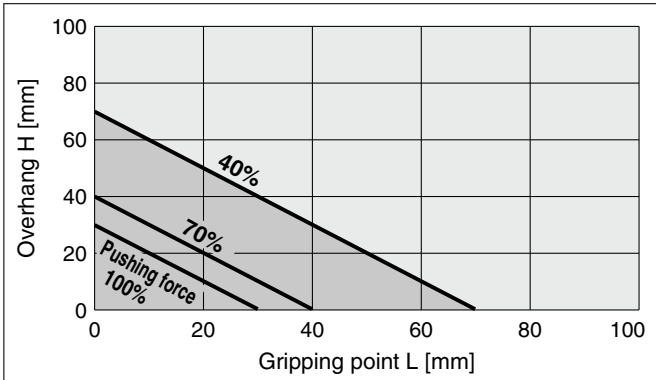

### Compact

\* Pushing force is one of the values of step data that is input into the controller.

#### LEHZ10L

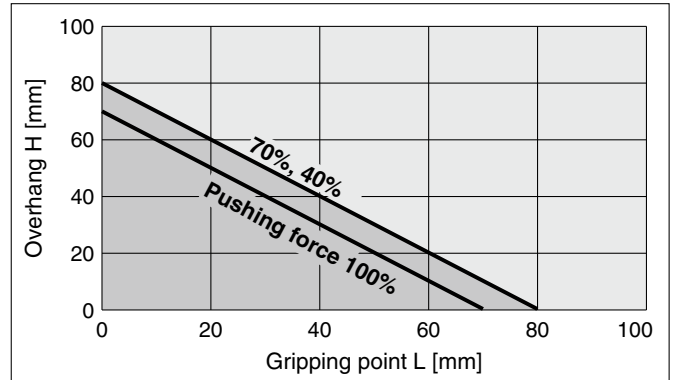

#### LEHZ16

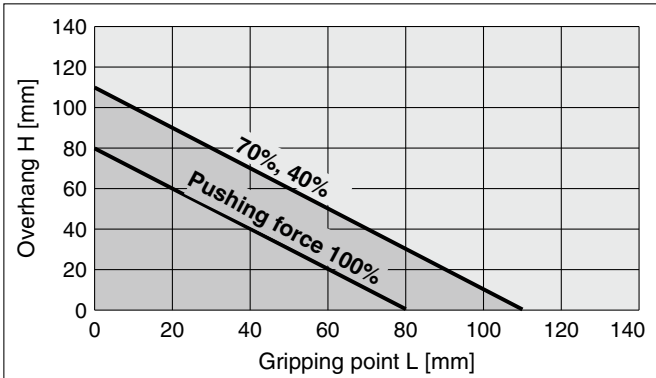

#### LEHZ16L

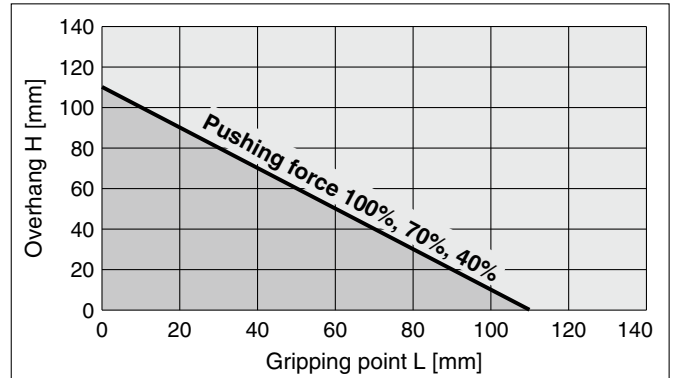

#### LEHZ20

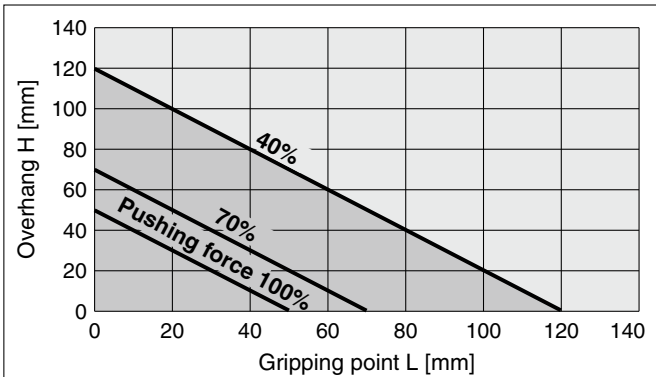

#### LEHZ20L

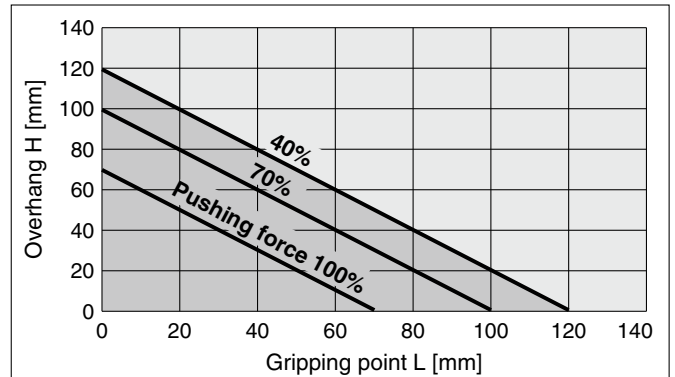

# Series LEHZ

## Selection Procedure

### Step 2 Check the gripping point and overhang: Series LEHZ

#### Basic

\* Pushing force is one of the values of step data that is input into the controller.

##### LEHZ25

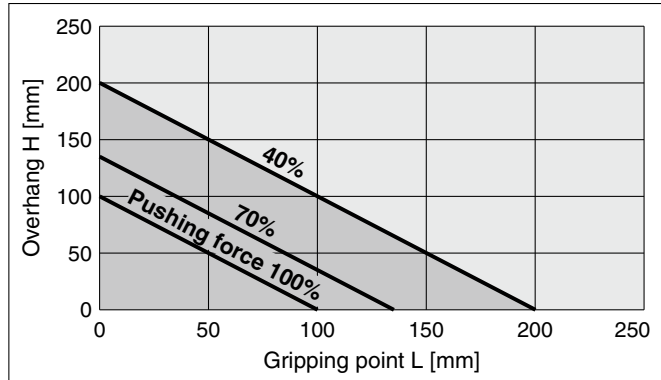

##### LEHZ32

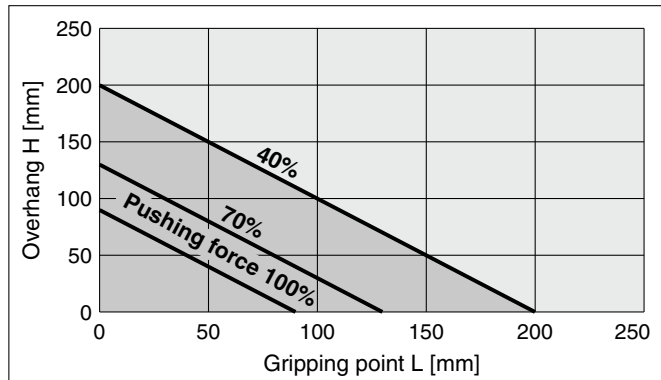

##### LEHZ40

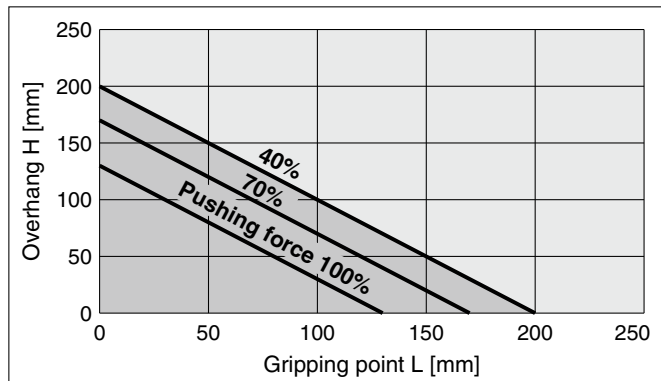

#### Compact

\* Pushing force is one of the values of step data that is input into the controller.

##### LEHZ25L

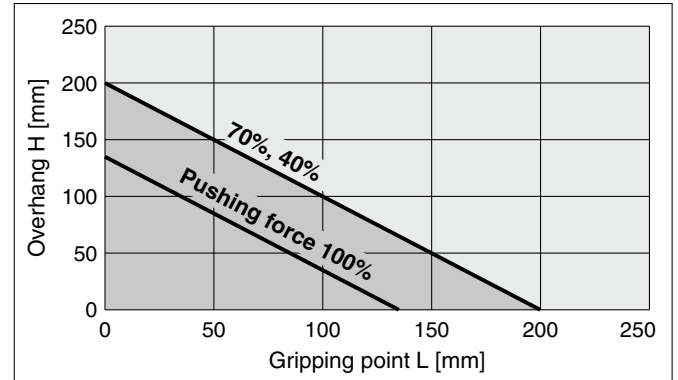

**Step 3** Check the external force on fingers: **Series LEHZ**

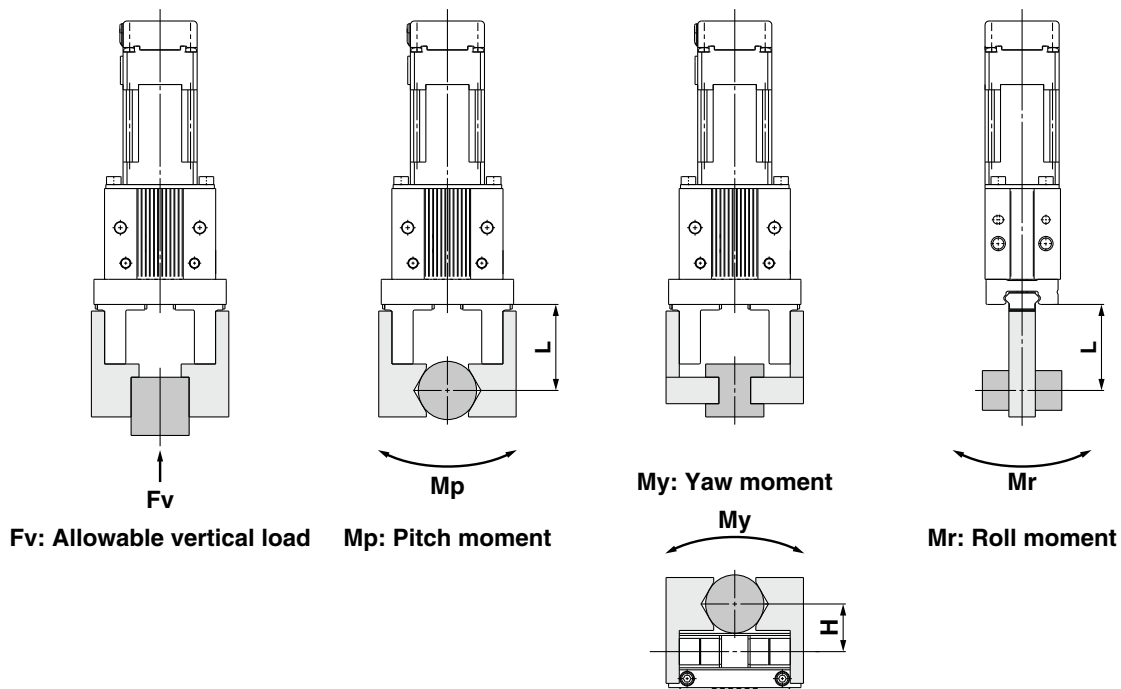

H, L: Distance to the point at which the load is applied (mm)

Model	Allowable vertical load Fv [N]	Static allowable moment		
		Pitch moment: Mp [N·m]	Yaw moment: My [N·m]	Roll moment: Mr [N·m]
LEHZ10(L)K2-4	58	0.26	0.26	0.53
LEHZ16(L)K2-6	98	0.68	0.68	1.36
LEHZ20(L)K2-10	147	1.32	1.32	2.65
LEHZ25(L)K2-14	255	1.94	1.94	3.88
LEHZ32(L)K2-22	343	3	3	6
LEHZ40(L)K2-30	490	4.5	4.5	9

Note) Values for load in the table indicate static values.

Calculation of allowable external force (when moment load is applied)	Calculation example
$\text{Allowable load } F \text{ (N)} = \frac{M \text{ (Static allowable moment) (N·m)}}{L \times 10^{-3} \text{ (*)}}$ <p>(* Constant for unit conversion)</p>	<p>When a static load of <math>f = 10 \text{ N}</math> is operating, which applies pitch moment to point <math>L = 30 \text{ mm}</math> from the LEHZ16K2-6 guide. Therefore, it can be used.</p> $\text{Allowable load } F = \frac{0.68}{30 \times 10^{-3}} = 22.7 \text{ (N)}$ <p><b>Load <math>f = 10 \text{ (N)} &lt; 22.7 \text{ (N)}</math></b></p>

# Electric Gripper 2-Finger Type

Step Motor (Servo/24 VDC)

# Series LEHZ

## LEHZ10, 16, 20, 25, 32, 40



### How to Order

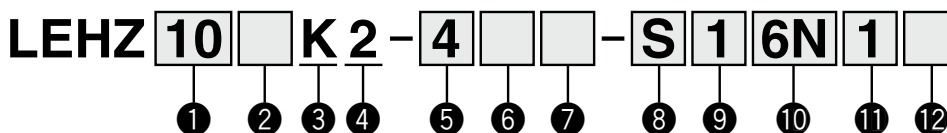

#### ① Size

10
16
20
25
32
40

#### ② Motor size

Nil	Basic
L (Note)	Compact

Note) Size: 10, 16, 20, 25 only

#### ③ Lead

K	Basic
---	-------

#### ④ 2-finger type

#### Finger options

Nil: Basic  
(Tapped in opening/closing direction)

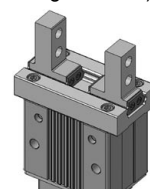

A: Side tapped mounting

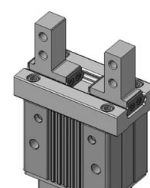

B: Through-hole in opening/closing direction

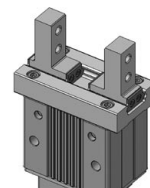

C: Flat fingers

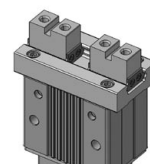

#### ⑤ Stroke [mm]

Stroke/both sides	Size
4	10
6	16
10	20
14	25
22	32
30	40

#### ⑥ Finger options

Nil	Basic (Tapped in opening/closing direction)
A	Side tapped mounting
B	Through-hole in opening/closing direction
C	Flat fingers

#### ⑦ Motor cable entry

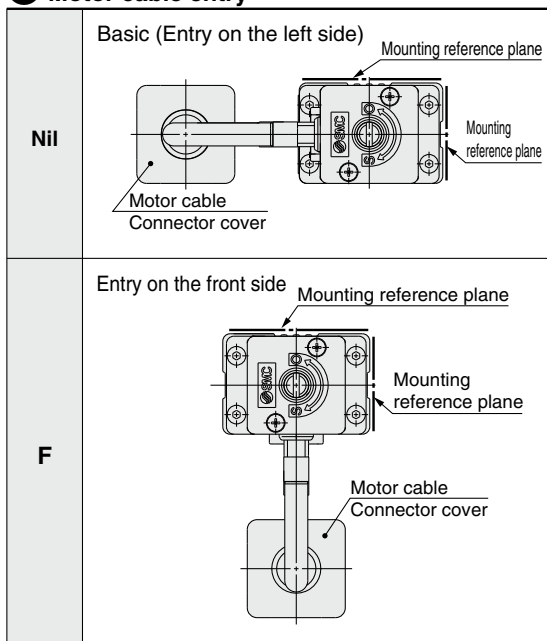

#### ⚠ Caution

##### [CE-compliant products]

EMC compliance was tested by combining the electric actuator LEH series and the controller LEC series.

The EMC depends on the configuration of the customer's control panel and the relationship with other electrical equipment and wiring. Therefore conformity to the EMC directive cannot be certified for SMC components incorporated into the customer's equipment under actual operating conditions. As a result it is necessary for the customer to verify conformity to the EMC directive for the machinery and equipment as a whole.

##### [UL-compliant products]

When conformity to UL is required, the electric actuator and controller/driver should be used with a UL1310 Class 2 power supply.

### The actuator and controller/driver are sold as a package.

Confirm that the combination of the controller/driver and the actuator is correct.

<Check the following before use.>

- ① Check the actuator label for model number. This matches the controller/driver.
- ② Check Parallel I/O configuration matches (NPN or PNP).

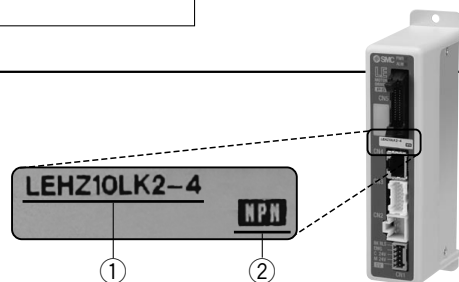

\* Refer to the operation manual for using the products. Please download it via our website, <http://www.smcworld.com>

# Electric Gripper 2-Finger Type *Series LEHZ*



## 8 Actuator cable type\*

Nil	Without cable
<b>S</b>	Standard cable
<b>R</b>	Robotic cable (Flexible cable)

\* The standard cable should be used on fixed parts. For using on moving parts, select the robotic cable.

## 9 Actuator cable length [m]

Nil	Without cable
<b>1</b>	1.5
<b>3</b>	3
<b>5</b>	5
<b>8</b>	8*
<b>A</b>	10*
<b>B</b>	15*
<b>C</b>	20*

\* Produced upon receipt of order (Robotic cable only)  
Refer to the specifications Note 3) on page 9.

## 10 Controller/Driver type\*

Nil	Without controller/driver	
<b>6N</b>	<b>LECP6</b> (Step data input type)	NPN
<b>6P</b>		PNP
<b>1N</b>	<b>LECP1</b> (Programless type)	NPN
<b>1P</b>		PNP
<b>AN</b>	<b>LECPA</b> (Pulse input type)	NPN
<b>AP</b>		PNP

\* For details about controllers/driver and compatible motors, refer to the compatible controllers/driver below.

## 11 I/O cable length [m]\*1

Nil	Without cable
<b>1</b>	1.5
<b>3</b>	3*2
<b>5</b>	5*2

\*1 When "Without controller/driver" is selected for controller/driver types, I/O cable cannot be selected. Refer to page 61 (For LECP6), page 73 (For LECP1) or page 80 (For LECPA) if I/O cable is required.



\*2 When "Pulse input type" is selected for controller/driver types, pulse input usable only with differential. Only 1.5 m cables usable with open collector.

## 12 Controller/Driver mounting

Nil	Screw mounting
<b>D</b>	DIN rail mounting*

\* DIN rail is not included. Order it separately.  
(Refer to page 56.)

## Compatible Controllers/Driver

Type	Step data input type 	Programless type 	Pulse input type 
Series	<b>LECP6</b>	<b>LECP1</b>	<b>LECPA</b>
Features	Value (Step data) input Standard controller	Capable of setting up operation (step data) without using a PC or teaching box	Operation by pulse signals
Compatible motor	Step motor (Servo/24 VDC)	Step motor (Servo/24 VDC)	
Maximum number of step data	64 points	14 points	—
Power supply voltage	24 VDC		
Reference page	Page 55	Page 68	Page 74

## Specifications



Model		LEHZ10	LEHZ16	LEHZ20	LEHZ25	LEHZ32	LEHZ40
Opening/closing stroke (Both sides)		4	6	10	14	22	30
Gripping force [N] <small>Note 1) Note 3)</small>	Basic	6 to 14		16 to 40		52 to 130	84 to 210
	Compact	2 to 6	3 to 8	11 to 28		—	—
Opening and closing speed/ Pushing speed [mm/s] <small>Note 2) Note 3)</small>		5 to 80/5 to 50		5 to 100/5 to 50		5 to 120/5 to 50	
Drive method		Slide screw + Slide cam					
Finger guide type		Linear guide (No circulation)					
Repeatability [mm] <small>Note 4)</small>		±0.02					
Repeated length measurement accuracy [mm] <small>Note 5)</small>		±0.05					
Finger backlash/ both sides [mm] <small>Note 6)</small>		0.5 or less				1.0 or less	
Impact/Vibration resistance [m/s <sup>2</sup> ] <small>Note 7)</small>		150/30					
Max. operating frequency [C.P.M]		60					
Operating temperature range [°C]		5 to 40					
Operating humidity range [%RH]		90 or less (No condensation)					
Weight [g]	Basic	165	220	430	585	1120	1760
	Compact	135	190	365	520	—	—
Motor size		□20		□28		□42	
Motor type		Step motor (Servo/24 VDC)					
Encoder		Incremental A/B phase (800 pulse/rotation)					
Rated voltage [V]		24 VDC ±10%					
Power consumption/ Standby power consumption when operating [W] <small>Note 8)</small>	Basic	11/7		28/15		34/13	36/13
	Compact	8/7		22/12		—	—
Max. instantaneous power consumption [W] <small>Note 9)</small>	Basic	19		51		57	61
	Compact	14		42		—	—

- Note 1) Gripping force should be from 10 to 20 times the workpiece weight. Positioning force should be 150% when releasing the workpiece. Gripping force accuracy should be ±30% (F.S.) for LEHZ10/16, ±25% (F.S.) for LEHZ20/25 and ±20% (F.S.) for LEHZ32/40.
- Note 2) Pushing speed should be set within the range during pushing (gripping) operation. Otherwise, it may cause malfunction. The opening/closing speed and pushing speed are for both fingers. The speed for one finger is half this value.
- Note 3) The speed and force may change depending on the cable length, load and mounting conditions. Furthermore, if the cable length exceeds 5 m, then it will decrease by up to 10% for each 5 m. (At 15 m: Reduced by up to 20%)
- Note 4) Repeatability means the variation of the gripping position (workpiece position) when the gripping operation is repeatedly performed by the same sequence for the same workpiece.
- Note 5) Repeated length measurement accuracy means dispersion (value on the controller monitor) when the workpiece is repeatedly held in the same position.
- Note 6) There will be no influence of backlash during pushing (gripping) operation. Make the stroke longer for the amount of backlash when opening.
- Note 7) Impact resistance: No malfunction occurred when the gripper was tested with a drop tester in both an axial direction and a perpendicular direction to the lead screw. (Test was performed with the gripper in the initial state.)  
Vibration resistance: No malfunction occurred in a test ranging between 45 to 2000 Hz. Test was performed in both an axial direction and a perpendicular direction to the lead screw. (Test was performed with the gripper in the initial state.)
- Note 8) The power consumption (including the controller) is for when the gripper is operating.  
The standby power consumption when operating is for when the gripper is stopped in the set position during operation, including the energy saving mode when gripping.
- Note 9) The maximum instantaneous power consumption (including the controller) is for when the gripper is operating. This value can be used for the selection of the power supply.

## How to Mount

a) When using the thread on the side of the body

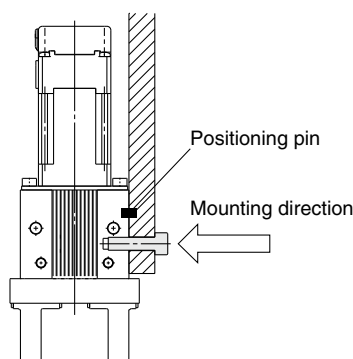

b) When using the thread on the mounting plate

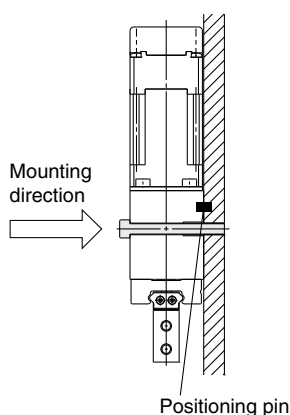

c) When using the thread on the back of the body

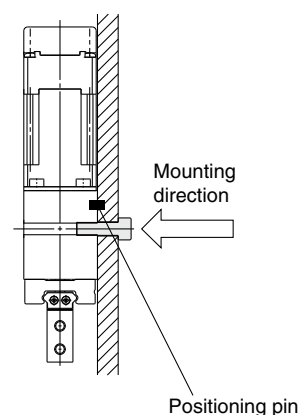

**Construction**

**Series LEHZ**

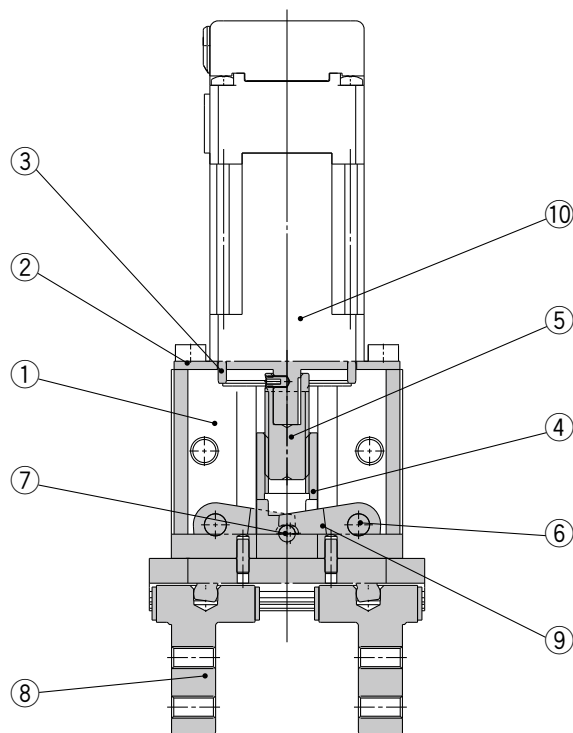

**Component Parts**

No.	Description	Material	Note
1	<b>Body</b>	Aluminum alloy	Anodized
2	<b>Motor plate</b>	Aluminum alloy	Anodized
3	<b>Guide ring</b>	Aluminum alloy	
4	<b>Slide nut</b>	Stainless steel	Heat treatment + Special treatment
5	<b>Slide bolt</b>	Stainless steel	Heat treatment + Special treatment
6	<b>Needle roller</b>	High carbon chromium bearing steel	
7	<b>Needle roller</b>	High carbon chromium bearing steel	
8	<b>Finger assembly</b>	—	
9	<b>Lever</b>	Special stainless steel	
10	<b>Step motor (Servo/24 VDC)</b>	—	

**Replacement Parts** ⑧ **Finger Assembly**

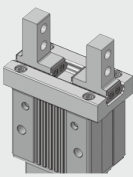
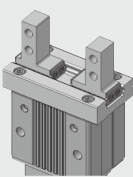
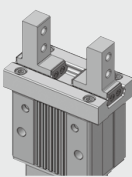
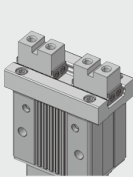
Size	Basic (Nil)	Side tapped mounting (A)	Through-hole in opening/ closing direction (B)	Flat fingers (C)
				
10	MHZ-A1002	MHZ-A1002-1	MHZ-A1002-2	MHZ-A1002-3
16	MHZ-A1602	MHZ-A1602-1	MHZ-A1602-2	MHZ-A1602-3
20	MHZ-A2002	MHZ-A2002-1	MHZ-A2002-2	MHZ-A2002-3
25	MHZ-A2502	MHZ-A2502-1	MHZ-A2502-2	MHZ-A2502-3
32	MHZ-A3202	MHZ-A3202-1	MHZ-A3202-2	MHZ-A3202-3
40	MHZ-A4002	MHZ-A4002-1	MHZ-A4002-2	MHZ-A4002-3

Model Selection

LEHZ

LEHZJ

Step Motor (Servo/24 VDC)

LEHF

LEHS

LECP6

LEC-G

LECP1

LECPA

Specific Product Precautions

# Series LEHZ

## Dimensions

### LEHZ10(L)K2-4

Model	L	(L <sub>1</sub> )
LEHZ10K2-4□	103.8	(59.7)
LEHZ10LK2-4□	87.2	(43.1)

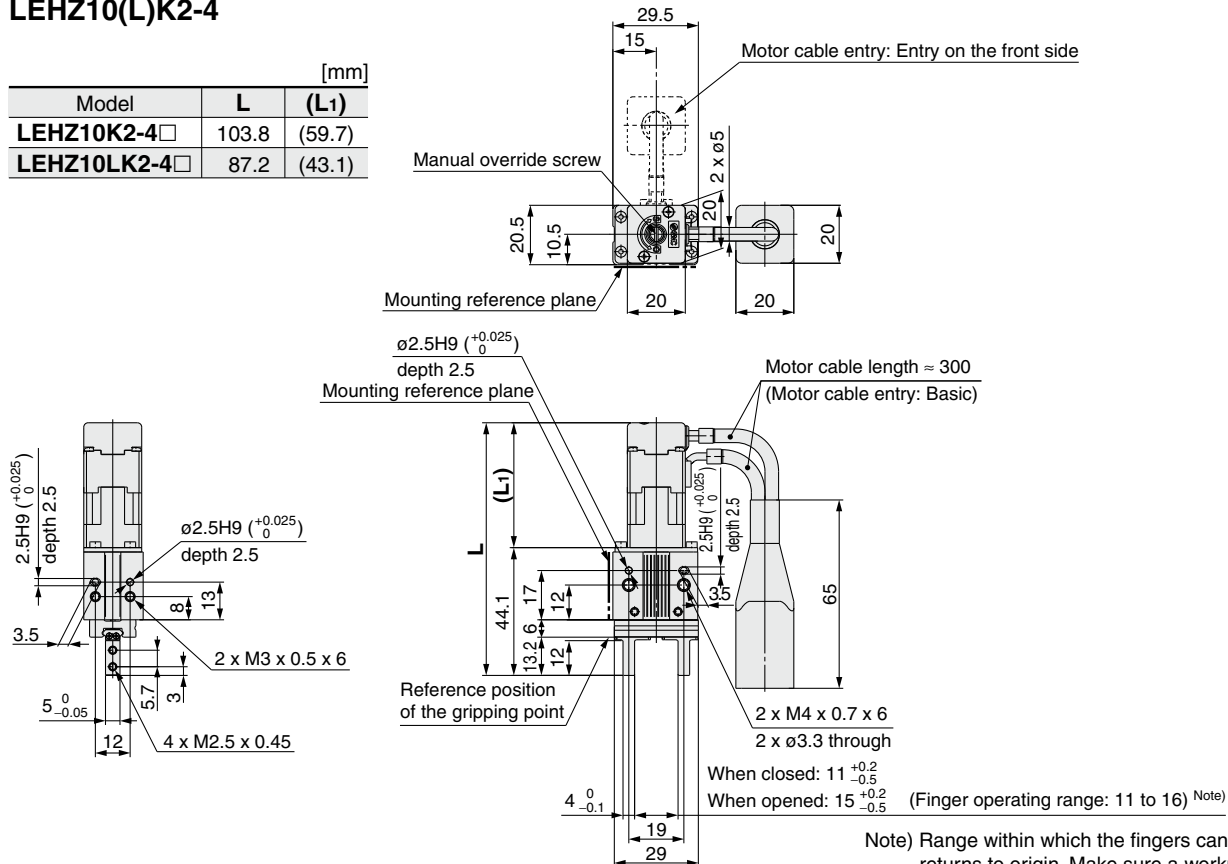

### LEHZ16(L)K2-6

Model	L	(L <sub>1</sub> )
LEHZ16K2-6□	112.8	(59.7)
LEHZ16LK2-6□	96.2	(43.1)

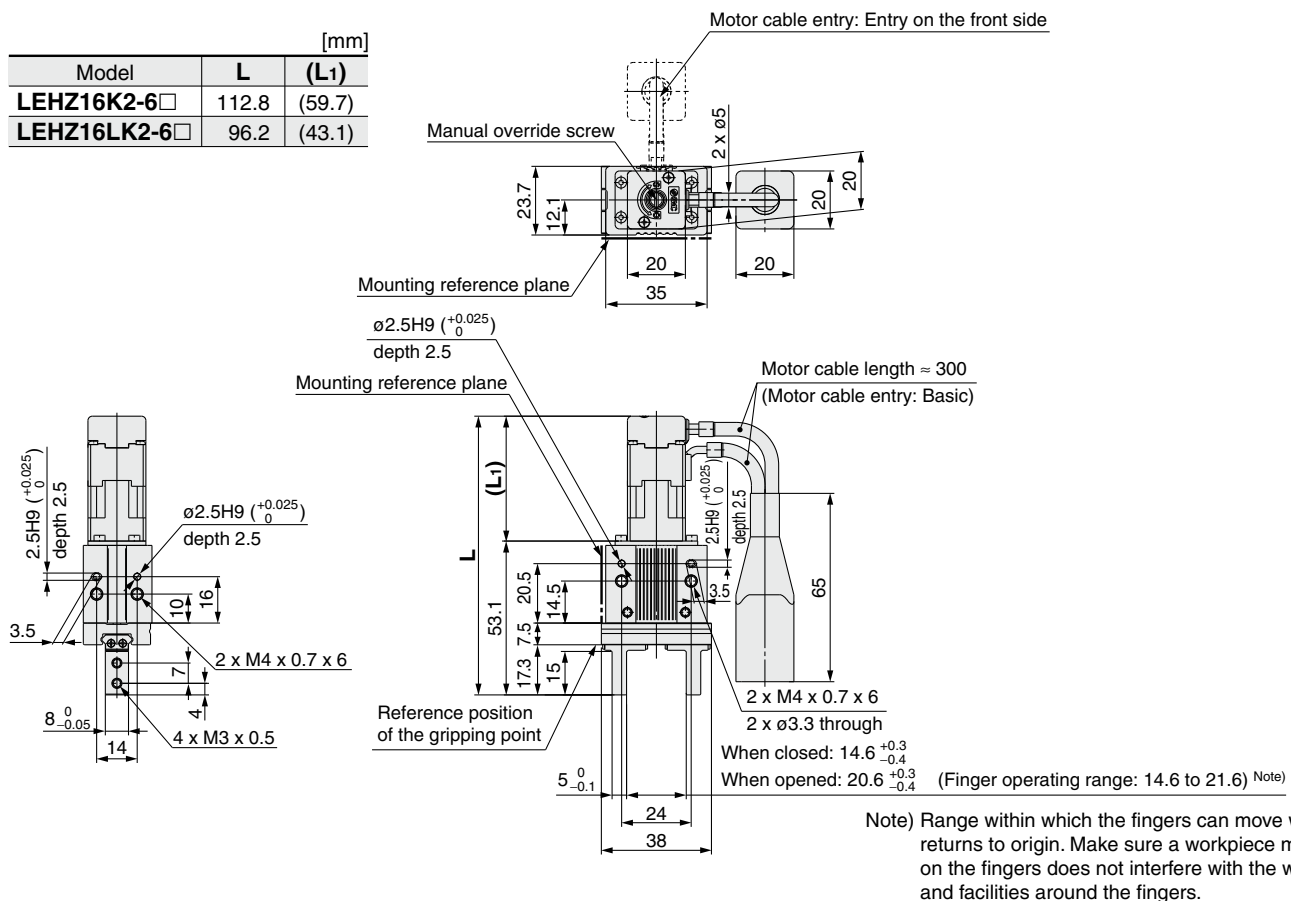

## Dimensions

### LEHZ20(L)K2-10

Model	L	(L1)
LEHZ20K2-10□	129.6	(61.8)
LEHZ20LK2-10□	115.6	(47.8)

[mm]

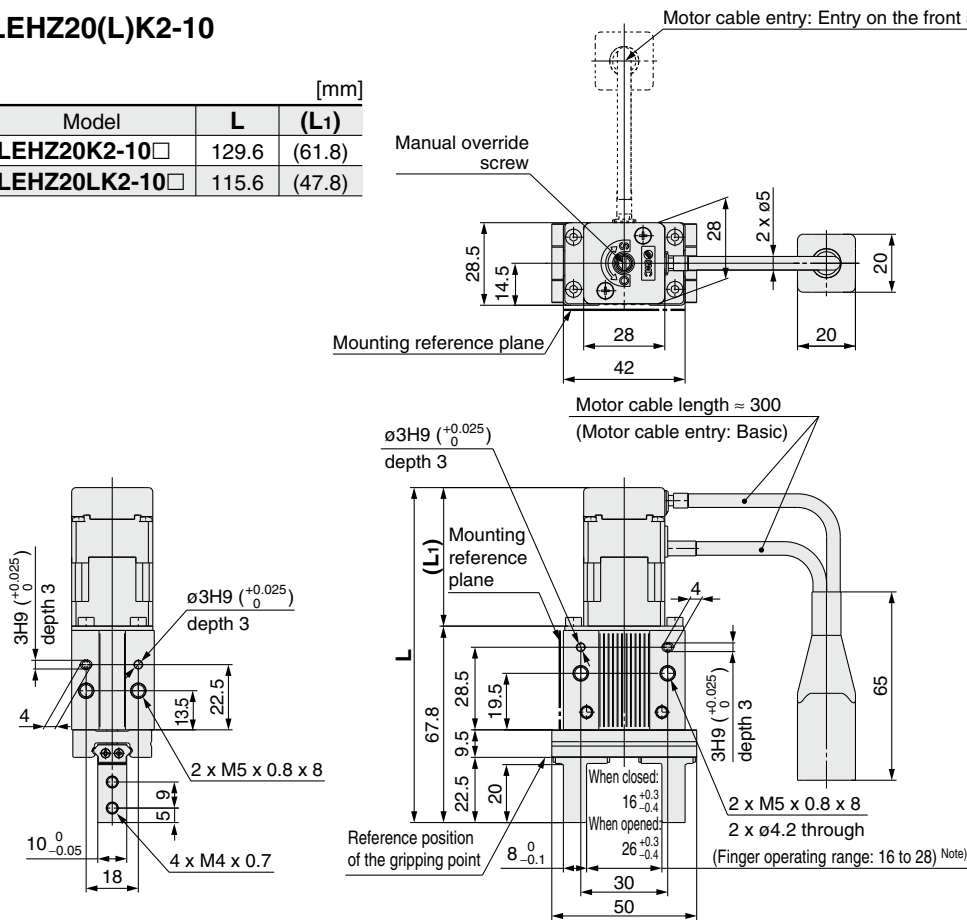

Note) Range within which the fingers can move when it returns to origin. Make sure a workpiece mounted on the fingers does not interfere with the workpieces and facilities around the fingers.

### LEHZ25(L)K2-14

Model	L	(L1)
LEHZ25K2-14□	139.8	(61.8)
LEHZ25LK2-14□	125.8	(47.8)

[mm]

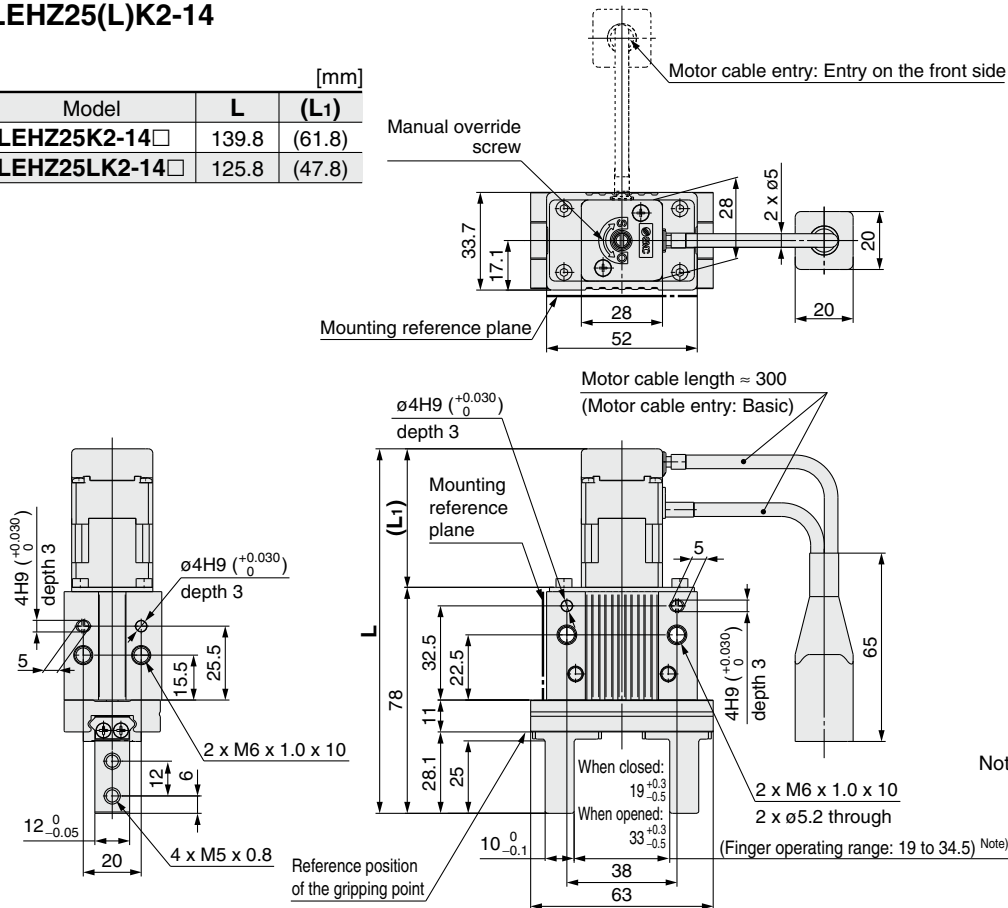

Note) Range within which the fingers can move when it returns to origin. Make sure a workpiece mounted on the fingers does not interfere with the workpieces and facilities around the fingers.



# Series LEHZ

## Finger Options

### Side Tapped Mounting (A)

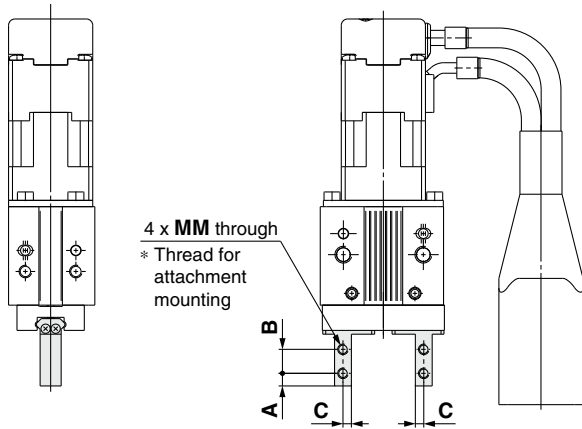

Model	A	B	C	MM
LEHZ10(L)K2-4A□	3	5.7	2	M2.5 x 0.45
LEHZ16(L)K2-6A□	4	7	2.5	M3 x 0.5
LEHZ20(L)K2-10A□	5	9	4	M4 x 0.7
LEHZ25(L)K2-14A□	6	12	5	M5 x 0.8
LEHZ32K2-22A□	7	14	6	M6 x 1
LEHZ40K2-30A□	9	17	7	M8 x 1.25

### Through-hole in Opening/Closing Direction (B)

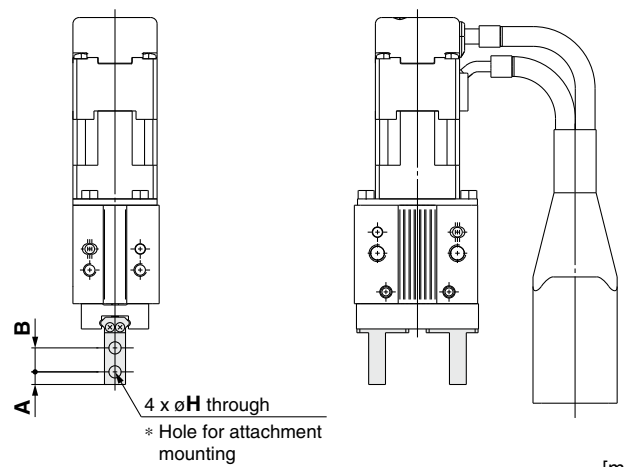

Model	A	B	H
LEHZ10(L)K2-4B□	3	5.7	2.9
LEHZ16(L)K2-6B□	4	7	3.4
LEHZ20(L)K2-10B□	5	9	4.5
LEHZ25(L)K2-14B□	6	12	5.5
LEHZ32K2-22B□	7	14	6.6
LEHZ40K2-30B□	9	17	9

### Flat Fingers (C)

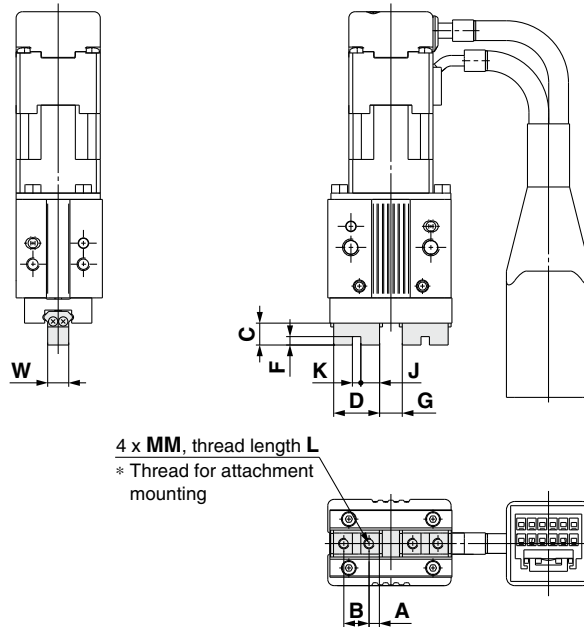

Model	A	B	C	D	F	G		J	K	MM	L	W	Weight (g)
						When opened	When closed						
LEHZ10K2-4C□	2.45	6	5.2	10.9	2	5.4 <sup>0</sup> <sub>-0.2</sub>	1.4 <sup>0</sup> <sub>-0.2</sub>	4.45	2H9 <sup>+0.025</sup> <sub>0</sub>	M2.5 x 0.45	5	5 <sup>0</sup> <sub>-0.05</sub>	165
LEHZ10LK2-4C□						135							
LEHZ16K2-6C□	3.05	8	8.3	14.1	2.5	7.4 <sup>0</sup> <sub>-0.2</sub>	1.4 <sup>0</sup> <sub>-0.2</sub>	5.8	2.5H9 <sup>+0.025</sup> <sub>0</sub>	M3 x 0.5	6	8 <sup>0</sup> <sub>-0.05</sub>	220
LEHZ16LK2-6C□						190							
LEHZ20K2-10C□	3.95	10	10.5	17.9	3	11.6 <sup>0</sup> <sub>-0.2</sub>	1.6 <sup>0</sup> <sub>-0.2</sub>	7.45	3H9 <sup>+0.025</sup> <sub>0</sub>	M4 x 0.7	8	10 <sup>0</sup> <sub>-0.05</sub>	430
LEHZ20LK2-10C□						365							
LEHZ25K2-14C□	4.9	12	13.1	21.8	4	16 <sup>0</sup> <sub>-0.2</sub>	2 <sup>0</sup> <sub>-0.2</sub>	8.9	4H9 <sup>+0.030</sup> <sub>0</sub>	M5 x 0.8	10	12 <sup>0</sup> <sub>-0.05</sub>	575
LEHZ25LK2-14C□						510							
LEHZ32K2-22C□	7.3	20	18	34.6	5	25 <sup>0</sup> <sub>-0.2</sub>	3 <sup>0</sup> <sub>-0.2</sub>	14.8	5H9 <sup>+0.030</sup> <sub>0</sub>	M6 x 1	12	15 <sup>0</sup> <sub>-0.05</sub>	1145
LEHZ40K2-30C□	8.7	24	22	41.4	6	33 <sup>0</sup> <sub>-0.2</sub>	3 <sup>0</sup> <sub>-0.2</sub>	17.7	6H9 <sup>+0.030</sup> <sub>0</sub>	M8 x 1.25	16	18 <sup>0</sup> <sub>-0.05</sub>	1820

Model Selection

LEHZ

LEHZJ

Step Motor (Servo24 VDC)

LEHF

LEHS

LECP6

LEC-G

LECP1

LECPA

Specific Product Precautions