

Video Decoder EI3 Extender Board Manual

an EZ-Extender® product

Revision 1.1, November 2012

Part Number
82-000253-01

Analog Devices, Inc.
One Technology Way
Norwood, Mass. 02062-9106



Copyright Information

© 2012 Analog Devices, Inc., ALL RIGHTS RESERVED. This document may not be reproduced in any form without prior, express written consent from Analog Devices, Inc.

Printed in the USA.

Disclaimer

Analog Devices, Inc. reserves the right to change this product without prior notice. Information furnished by Analog Devices is believed to be accurate and reliable. However, no responsibility is assumed by Analog Devices for its use; nor for any infringement of patents or other rights of third parties which may result from its use. No license is granted by implication or otherwise under the patent rights of Analog Devices, Inc.

Trademark and Service Mark Notice

The Analog Devices logo, Blackfin, CrossCore, EngineerZone, EZ-Board, EZ-Extender, EZ-KIT Lite, and VisualDSP++ are registered trademarks of Analog Devices, Inc.

All other brand and product names are trademarks or service marks of their respective owners.

Regulatory Compliance

The Video Decoder EI3 Extender Board is designed to be used solely in a laboratory environment. The board is not intended for use as a consumer end product or as a portion of a consumer end product. The board is an open system design which does not include a shielded enclosure and therefore may cause interference to other electrical devices in close proximity. This board should not be used in or near any medical equipment or RF devices.

The Video Decoder EI3 Extender Board has been certified to comply with the essential requirements of the European EMC directive 2004/108/EC and therefore carries the “CE” mark.

The Video Decoder EI3 Extender Board has been appended to Analog Devices, Inc. EMC Technical File (EMC TF) referenced **DSPTOOLS1**, issue 2 dated June 4, 2008 and was declared CE compliant by an appointed Notified Body (No.0673) as listed below.

Notified Body Statement of Compliance: Z600ANA2.045 dated September 3, 2012.



Issued by: Technology International (Europe) Limited
56 Shrivenham Hundred Business Park
Shrivenham, Swindon, SN6 8TY, UK

The extender board contains ESD (electrostatic discharge) sensitive devices. Electrostatic charges readily accumulate on the human body and equipment and can discharge without detection. Permanent damage may occur on devices subjected to high-energy discharges. Proper ESD precautions are recommended to avoid performance degradation or loss of functionality. Store unused extender boards in the protective shipping package.



CONTENTS

PREFACE

Product Overview	ix
Purpose of This Manual	x
Intended Audience	xi
Manual Contents	xi
What's New in This Manual	xii
Technical Support	xii
Supported Products	xiii
Product Information	xiii
Analog Devices Web Site	xiv
EngineerZone	xiv
Related Documents	xv
Notation Conventions	xv

USING VIDEO DECODER EI3 EXTENDER BOARD

Package Contents	1-2
Video Decoder EI3 Extender Board Installation	1-2
High-Performance HDMI Receiver (ADV7842)	1-3
Expansion Interface III	1-5

Contents

Example Programs	1-6
Board Design Database	1-6

VIDEO DECODER EI3 EXTENDER BOARD HARDWARE REFERENCE

System Architecture	2-2
Software-Controlled Switches (SoftConfig)	2-3
Overview of SoftConfig	2-3
Programming SoftConfig	2-7
ADV7842_INT_GPIOx Signal	2-9
SPORT_ENABLE Signal	2-9
Connectors	2-10
Component Connector (J1)	2-11
S-Video Connector (J2)	2-11
VGA Connector (J3)	2-11
Expansion Interface III (EI3) Connectors (J4)	2-12
HDMI Connector (J5–6)	2-12
Composite Connector (J7)	2-13
Power Connector (P1)	2-13
LEDs	2-14
HDMI Detect LED (LED1–2)	2-14
Power LED (LED3)	2-14

VIDEO DECODER EI3 EXTENDER BOARD BILL OF

Contents

MATERIALS

VIDEO DECODER EI3 EXTENDER BOARD SCHEMATIC

INDEX

Contents

PREFACE

Thank you for purchasing the Video Decoder EI3 Extender Board, an EZ-Extender[®] for EZ-KIT Lite[®]/EZ-Board[®] evaluation systems with the expansion interface 3 (EI3).

The EZ-KIT Lite/EZ-Board and Video Decoder EI3 Extender Board are designed to be used in conjunction with the CrossCore[®] Embedded Studio (CCES) development environment.

To learn more about Analog Devices development software, go to <http://www.analog.com/processors/tools>.

Product Overview

The Video Decoder EI3 Extender Board is a separately sold daughter board that plugs onto the EI3 of an EZ-KIT Lite/EZ-Board evaluation system. The extender board aids the design and prototyping phases of embedded processor-targeted applications.

The board extends the capabilities of the evaluation system by providing a connection between the parallel peripheral interface (PPI) of the processor and the ADV7842 video decoder. The serial port interface (SPORT) is used to receive audio data. The two-wire interface (TWI) port of the processor is used to communicate with the video decoders and SoftConfig on the extender.

Purpose of This Manual

The following is a list of the Video Decoder EI3 Extender Board interfaces.

- Video interface
 - ADV7842 — Dual HDMI 1.4 fast switching receiver with 12-bit, 170 MHz video and graphics digitizer and 3-D comb filter decoder
- Video connectors
 - Two HDMI
 - One SVIDEO
 - One component
 - One composite
 - One VGA
- Software-controlled switches for board configuration
- Expansion Interface III
- No power supply required: derives power from the EZ-KIT Lite/EZ-Board
- CE certified

Purpose of This Manual

The *Video Decoder EI3 Extender Board Manual* provides instructions for installing the product hardware (board). The text describes operation and configuration of the board components and provides guidelines for running your own code on the Video Decoder EI3 Extender Board. Finally, a schematic and a bill of materials are provided for reference.

Intended Audience

The primary audience for this manual is a programmer who is familiar with Analog Devices processors. This manual assumes that the audience has a working knowledge of the appropriate processor architecture, instruction set, and C/C++ programming languages.

Programmers who are unfamiliar with Analog Devices processors can use this manual, but should supplement it with other texts that describe your target architecture and hardware development tools.

Programmers who are unfamiliar with the CrossCore Embedded Studio programming environment or the mating evaluation board, should refer to the CCES online help or the manual describing the board (see [“Related Documents”](#)).

Manual Contents

The manual consists of:

- Chapter 1, [“Using Video Decoder EI3 Extender Board” on page 1-1](#)
Provides basic product information.
- Chapter 2, [“Video Decoder EI3 Extender Board Hardware Reference” on page 2-1](#)
Provides information about the product’s hardware components.
- Appendix A, [“Video Decoder EI3 Extender Board Bill Of Materials” on page A-1](#)
Provides a list of hardware components used to manufacture the board.

What's New in This Manual

- Appendix B, “[Video Decoder EI3 Extender Board Schematic](#)” on [page B-1](#)
Provides all circuits on the extender board.

What's New in This Manual

This is the second revision of the *Video Decoder EI3 Extender Board Manual*. It includes the updated regulatory compliance section and minor modifications based on the errata report against the first revision.

Technical Support

You can reach Analog Devices processors and DSP technical support in the following ways:

- Post your questions in the processors and DSP support community at EngineerZone[®]:
<http://ez.analog.com/community/dsp>
- Submit your questions to technical support directly at:
<http://www.analog.com/support>
- E-mail your questions about processors, DSPs, and tools development software from **CrossCore Embedded Studio** or **VisualDSP++[®]**:

Choose **Help > Email Support**. This creates an e-mail to processor.tools.support@analog.com and automatically attaches your **CrossCore Embedded Studio** or **VisualDSP++** version information and `license.dat` file.

- E-mail your questions about processors and processor applications to:
processor.support@analog.com or
processor.china@analog.com (Greater China support)
- In the **USA only**, call 1-800-ANALOGD (1-800-262-5643)
- Contact your Analog Devices sales office or authorized distributor. Locate one at:
www.analog.com/adi-sales
- Send questions by mail to:
Processors and DSP Technical Support
Analog Devices, Inc.
Three Technology Way
P.O. Box 9106
Norwood, MA 02062-9106
USA

Supported Products

This extender board supports EZ-KIT Lite/EZ-Board evaluation systems with EI3.

Product Information

Product information can be obtained from the Analog Devices Web site and the CCES online help system.

Analog Devices Web Site

The Analog Devices Web site, www.analog.com, provides information about a broad range of products— analog integrated circuits, amplifiers, converters, and digital signal processors.

To access a complete technical library for each processor family, go to http://www.analog.com/processors/technical_library. The manuals selection opens a list of current manuals related to the product as well as a link to the previous revisions of the manuals. When locating your manual title, note a possible errata check mark next to the title that leads to the current correction report against the manual.

Also note, myAnalog.com is a free feature of the Analog Devices Web site that allows customization of a Web page to display only the latest information about products you are interested in. You can choose to receive weekly e-mail notifications containing updates to the Web pages that meet your interests, including documentation errata against all manuals. myAnalog.com provides access to books, application notes, data sheets, code examples, and more.

Visit myAnalog.com (found on the Analog Devices home page) to sign up. If you are a registered user, just log on. Your user name is your e-mail address.

EngineerZone

EngineerZone is a technical support forum from Analog Devices. It allows you direct access to ADI technical support engineers. You can search FAQs and technical information to get quick answers to your embedded processing and DSP design questions.

Use EngineerZone to connect with other DSP developers who face similar design challenges. You can also use this open forum to share knowledge and collaborate with the ADI support team and your peers. Visit <http://ez.analog.com> to sign up.

Related Documents

For additional information about the processor, refer to the following publications.

Table 1. Related Processor Publications



Title	Description
<i>Processor Data Sheet</i>	General functional description, pinout, and timing of the processor
<i>Processor Hardware Reference</i>	Description of the internal processor architecture and all register functions
<i>Blackfin® Processor Programming Reference</i>	Description of all allowed processor assembly instructions

Notation Conventions

Text conventions used in this manual are identified and described as follows.

Example	Description
Close command (File menu)	Titles in reference sections indicate the location of an item within the CCES environment's menu system (for example, the Close command appears on the File menu).
{this that}	Alternative required items in syntax descriptions appear within curly brackets and separated by vertical bars; read the example as <i>this</i> or <i>that</i> . One or the other is required.
[this that]	Optional items in syntax descriptions appear within brackets and separated by vertical bars; read the example as an optional <i>this</i> or <i>that</i> .
[this,...]	Optional item lists in syntax descriptions appear within brackets delimited by commas and terminated with an ellipsis; read the example as an optional comma-separated list of <i>this</i> .

Notation Conventions

Example	Description
.SECTION	Commands, directives, keywords, and feature names are in text with letter gothic font.
<i>filename</i>	Non-keyword placeholders appear in text with italic style format.
	Note: For correct operation, ... A Note provides supplementary information on a related topic. In the online version of this book, the word Note appears instead of this symbol.
	Caution: Incorrect device operation may result if ... Caution: Device damage may result if ... A Caution identifies conditions or inappropriate usage of the product that could lead to undesirable results or product damage. In the online version of this book, the word Caution appears instead of this symbol.
	Warning: Injury to device users may result if ... A Warning identifies conditions or inappropriate usage of the product that could lead to conditions that are potentially hazardous for the devices users. In the online version of this book, the word Warning appears instead of this symbol.

1 USING VIDEO DECODER EI3 EXTENDER BOARD

This chapter provides the setup procedure for the Video Decoder EI3 Extender Board and describes two types of interfaces the extender supports.

The information is presented in the following order.

- [“Package Contents” on page 1-2](#)
- [“Video Decoder EI3 Extender Board Installation” on page 1-2](#)
- [“High-Performance HDMI Receiver \(ADV7842\)” on page 1-3](#)
- [“Expansion Interface III” on page 1-5](#)
- [“Example Programs” on page 1-6](#)
- [“Board Design Database” on page 1-6](#)

For information about the CCES integrated development environment (IDE), refer to the online help.

Package Contents

Your Video Decoder EI3 Extender Board package contains the following items.

- Video Decoder EI3 Extender Board
- A bag containing hardware for securing the extender board onto the EZ-KIT Lite/EZ-Board
- Two video cables: one HDMI and one component
- Release notes containing information about the product download

Contact the vendor where you purchased your extender board or contact Analog Devices, Inc. if any item is missing.

Video Decoder EI3 Extender Board Installation

Follow these instructions to ensure correct operation of the product hardware and software.

1. Attach the extender board to the EZ-KIT Lite/EZ-Board.

The J1 connector on the extender board can be connected to the P1A, P2A, or P3A connector on the EZ-KIT Lite/EZ-Board. Refer to the example program for a reference to the proper connector.

2. Use the provided hardware to secure the extender to the EZ-KIT Lite/EZ-Board. See [Figure 1-1](#).

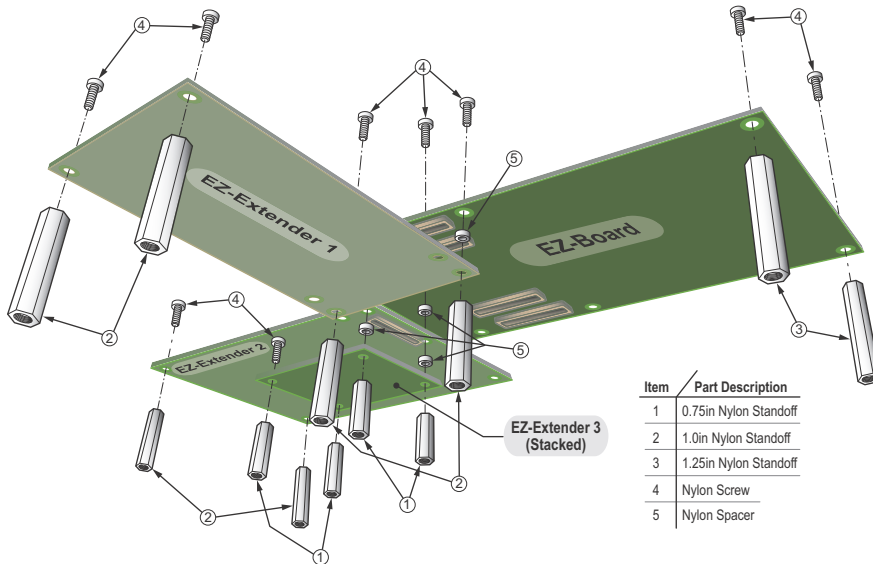

Figure 1-1. Assembled Board Diagram

3. Refer to the EZ-KIT Lite/EZ-Board manual for information on connecting to a personal computer (PC) and running CCES.

High-Performance HDMI Receiver (ADV7842)

The video interface consists of the ADV7842 dual HDMI fast switching receiver with video and graphics digitizer and 3-D comb filter. This device interfaces to the processor's parallel peripheral interface (PPI). It operates in 24-, 16- or 8-bit modes. YCbCr and RGB video modes are supported.

High-Performance HDMI Receiver (ADV7842)

The ADV7842 receiver is a high quality, single-chip, 2:1 multiplexed HDMI receiver and graphics digitizer with an integrated multi-format video decoder.

The ADV7842 receiver uses external 256 Mb DDR SDRAM for 3-D comb and frame synchronizer.

The ADV7842 receiver incorporates a dual input HDMI 1.4-compatible receiver that supports all HDTV formats up to 1080p and display resolutions up to UXGA. It also incorporates Xpressview fast switching on both input HDMI ports. Using the Analog Devices hardware-based HDCP engine that minimizes software overhead, Xpressview technology allows fast switching between any HDMI input ports in less than one second.

HDCP 1.4 support with internal HDCP keys. There is a version of the product, where the ADV7842 device is programmed with internal HDCP keys (ADZS-DECODEK-EX3). Consumers must have HDCP adopter status (consult Digital Content Protection, LLC for licensing requirements) to purchase any components with internal HDCP keys. In order to interface with consumer electronics, a board with internal HDCP keys is required.

The ADV7842 receiver supports all mandatory HDMI 1.4 3-D TV formats in addition to all HDTV formats up to 1080p.

The ADV7842 receiver also integrates an HDMI v1.4 CEC controller that supports the capability discovery and control (CDC) feature.

The ADV7842 receiver offers a flexible audio output port for the audio data decoded from the HDMI stream.

ADV7842 receiver can be configured to generate an interrupt based on various events. The TWI port is used for communication between the receiver and processor. The parallel peripheral interface (PPI) is used to receive video data. The serial port (SPORT) is used to receive audio data. An interrupt signal from the receiver is connected to a GPIO signal on the processor. The GPIO signal is configured via a software switch. Refer to

[“Video Decoder EI3 Extender Board Schematic”](#) on page B-1 for more information.

For more information about the ADV7842, go to www.analog.com and search for ADV7842.

An example program demonstrating capabilities of the ADV7842 device is available by installing the Video Decoder EI3 Extender Board Support Package (BSP).

Expansion Interface III

The Expansion Interface III (EI3) allows an extender board to be used across various hardware platforms that have the same expansion interface connectors.

The EI3 implemented on the Video Decoder EI3 Extender Board contains the PPI, SPORT, TWI and GPIO ports. These signals are used for the peripherals on the extender. The connectors contain a majority of the processor’s signals. For pinout information, go to [“Video Decoder EI3 Extender Board Schematic”](#) on page B-1. The mechanical dimensions of the expansion connectors can be obtained by contacting [“Technical Support”](#).

The Video Decoder EI3 Extender Board can interface with EZ-KIT Lites/EZ-Boards operating at an IO voltage of 3.3V. Other IO voltages are not supported. The extender can be powered from either the EZ-KIT Lite/EZ-Board or through the on-board 5V power connector (P1).

For more information about extender boards, visit the Analog Devices Web site (www.analog.com).

Limits to current and interface speed must be taken into consideration when using the EI3. Current for the EI3 can be sourced from the EZ-KIT Lite/EZ-Board; therefore, the current should be limited to 200 mA for 5V and 300 mA for the 3.3V planes. If more current is required, then a sepa-

Example Programs

rate power connector and a regulator must be designed on the daughter card. Additional circuitry can add extra loading to signals, decreasing their maximum effective speed.

 Analog Devices does not support and is not responsible for the effects of additional circuitry.

Example Programs

Example programs are included with the Video Decoder EI3 Extender Board BSP. Example programs demonstrate various capabilities of the product. The support package is installed on top of CrossCore Embedded Studio. Once installed, the example programs can be found in the `<install_path>\Video_Decoder_EI3_Extender_Board-RelX.X.X\Video_Decoder_EI3` directory where `X.X.X` denotes the support package release number.

Board Design Database

A .zip file containing all of the electronic information required for the design, layout, fabrication and assembly of the product is available for download from the Analog Devices board design database at:

<http://www.analog.com/en/processors-dsp/blackfin/processors/board-design-database/resources/index.html>.

2 VIDEO DECODER EI3 EXTENDER BOARD HARDWARE REFERENCE

This chapter describes the hardware design of the Video Decoder EI3 Extender Board.

The following topics are covered.

- [“System Architecture” on page 2-2](#)
Describes the daughter board configuration and explains how the board components interface with the processor.
- [“Software-Controlled Switches \(SoftConfig\)” on page 2-3](#)
List and describe signals routed through the software-controlled switches.
- [“Connectors” on page 2-10](#)
Shows the locations and provides part numbers for the on-board connectors. In addition, the manufacturer and part number information is provided for the mating parts.
- [“LEDs” on page 2-14](#)
Describes the on-board LEDs.

System Architecture

A block diagram of the Video Decoder EI3 Extender Board is shown in [Figure 2-1](#).

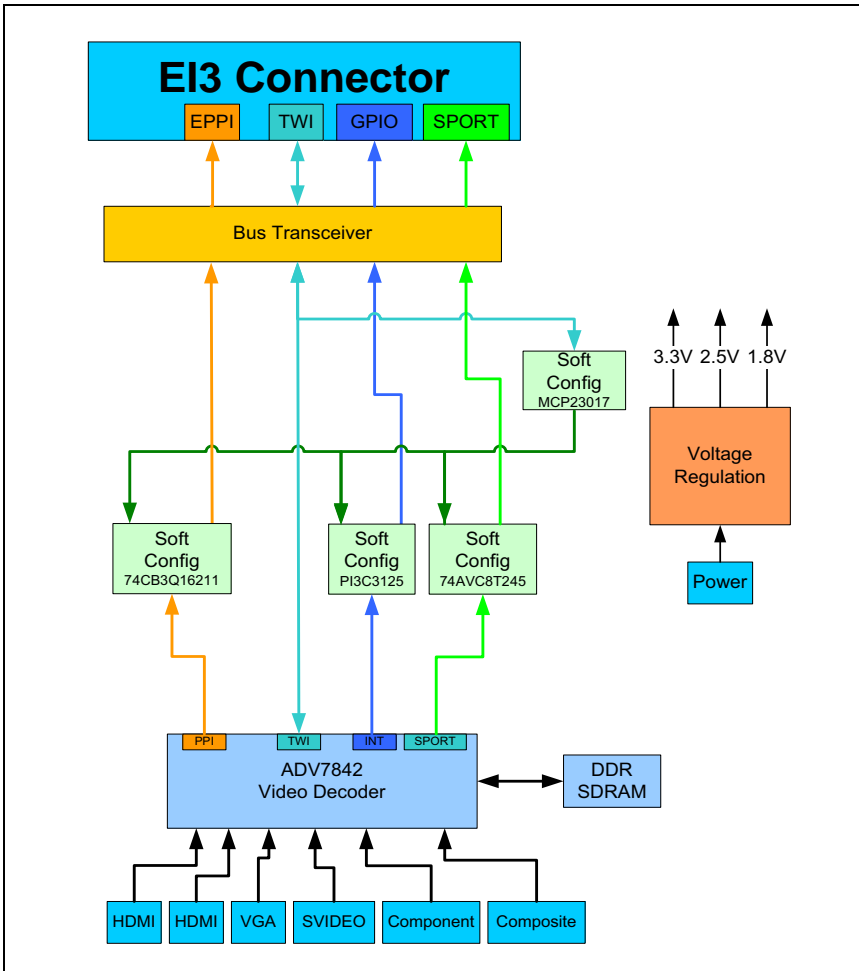



Figure 2-1. Video Decoder EI3 Extender Board Block Diagram

Software-Controlled Switches (SoftConfig)

On the Video Decoder EI3 Extender Board, all of the traditional mechanical switches and jumpers have been replaced by I²C software-controlled switches. Refer to any `SoftConfig*.c` file found in the installation directory of CCES for an example of how to set up the SoftConfig feature of the product through software.

The SoftConfig section of this manual serves as a reference to any user that intends to modify an existing software example. If software provided by ADI is used, there should be little need to reference this section.

 Care should be taken when changing SoftConfig settings not to create a conflict between interfaces.

Overview of SoftConfig

In order to further clarify the use of electronic single FET switches and multi-channel bus switches, an example of each is illustrated and compared to a traditional mechanical switching solution. This is a generic example. After the generic discussion, there is a detailed explanation of the SoftConfig interface specific to the extender board.

[Figure 2-2](#) shows two individual FET switches (Pericom PI3A125CEX) with reference designators UA and UB. Net names `ENABLE_A` and `ENABLE_B` control UA and UB. In this example, the default FET switch enable settings are controlled by resistors RA and RB which pull the enable pin 1 of UA and UB to ground (low). In a real example, these enable signals are controlled by the Microchip IO expander. The default pull-down resistors connect the signals `EXAMPLE_SIGNAL_A` and `EXAMPLE_SIGNAL_B` and also connect signals `EXAMPLE_SIGNAL_C` and `EXAMPLE_SIGNAL_D`. To disconnect `EXAMPLE_SIGNAL_A` from `EXAMPLE_SIGNAL_B`, the Microchip IO expander is used to change `ENABLE_A` to a logic 1 through software that interfaces with

Software-Controlled Switches (SoftConfig)

the Microchip. The same procedure for `ENABLE_B` disconnects `EXAMPLE_SIGNAL_C` from `EXAMPLE_SIGNAL_D`.

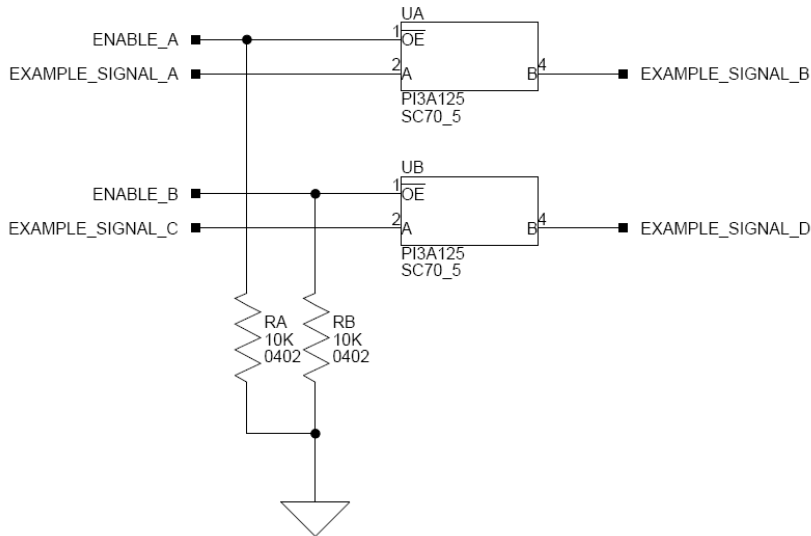

Figure 2-2. Example of Individual FET Switches

Figure 2-3 shows the equivalent circuit to Figure 2-2 but utilizes mechanical switches that are in the same package. The default is shown by black boxes located closer to the ON label of the switches. In order to disconnect these switches, physically move the switch to the OFF position.

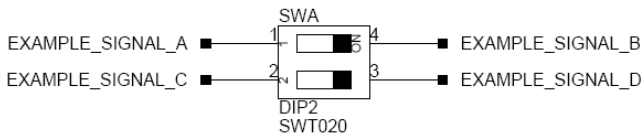

Figure 2-3. Example of Mechanical Switch Equivalent to Figure 2-2

Video Decoder EI3 Extender Board Hardware Reference

Figure 2-4 shows a bus switch example, reference designator UC (Pericom PI3LVD512ZHE), selecting between lettered functionality and numbered functionality. The signals on the left side are multiplexed signals with naming convention letter_number.

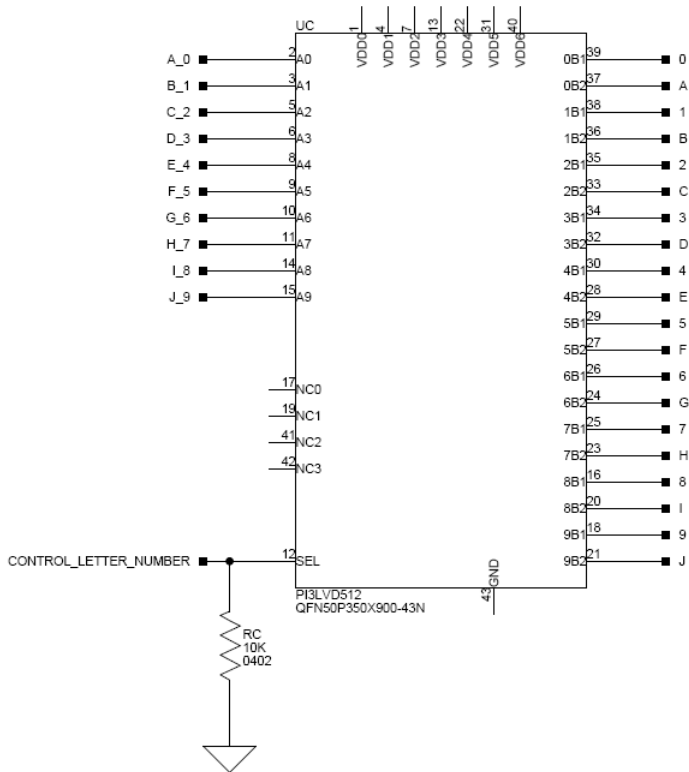

Figure 2-4. Example of a Bus Switch

The right side of the circuit shows the signals separated into letter and number, with the number on the lower group (eg. 0B1) and the letter on the upper group (eg. 0B2). The default setting is controlled by the signal CONTROL_LETTER_NUMBER which is pulled low. This selects the number signals on the right to be connected to the multiplexed signals on the left by

Software-Controlled Switches (SoftConfig)

default. In this example, the Microchip IO expander is not shown but controls the signal `CONTROL_LETTER_NUMBER` and allows the user to change the selection through software.

Figure 2-5 shows the equivalent circuit to Figure 2-4 but utilizes mechanical switches. Note the default for reference designators SWC and SWD is illustrated by black boxes located closer to the ON label of the switches to enable the number signals by default. Note the default setting for reference designators SWE and SWF is OFF. In order to connect the letters instead of the numbers, the user physically changes all switches on SWC and SWD to the OFF position and all switches on SWE and SEF to the ON position.

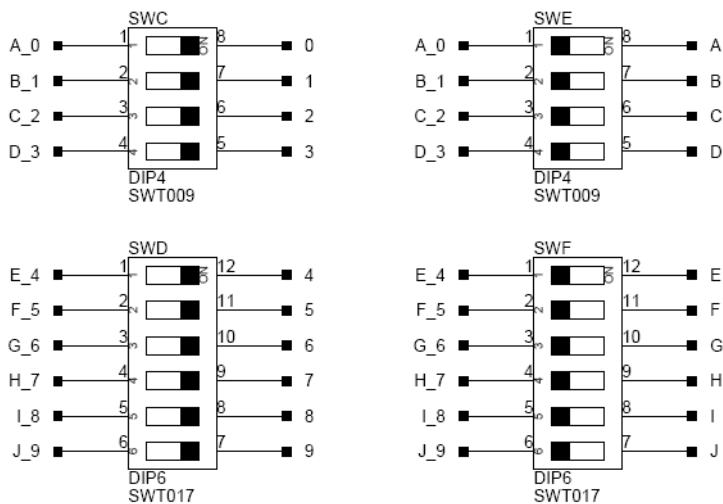

Figure 2-5. Example of Mechanical Switch Equivalent to Figure 2-4

Programming SoftConfig

On the Video Decoder EI3 Extender Board, a single Microchip MCP23017 device controls individual and electronic bus switches via TWI. The device has the following programming characteristics:

- There are two programmable GPIO registers.

GPIO Register	Register Address
GPIOA	0x12
GPIOB	0x13

- Each GPIO register controls eight signals (software switches).
- By default, the GPIO signals function as input signals; therefore, all electronic switches are in the OFF state.

The signals must be programmed as output signals to override their default values. The following table shows the Microchip register addresses and values that must be written to them to program the signals as output signals.

IODIR Register	IODIR Register Address	Value to be Written to Program Signals as Outputs
IODIRA	0x00	0
IODIRB	0x01	0

Each example in CrossCore Embedded Studio includes source files that program the soft switches, even if the default settings are being used. The README for each example identifies only the signals that are being changed

Software-Controlled Switches (SoftConfig)

from their default values. The code that programs the soft switches is located in two files:

- `SoftConfig_Decoder.c` for configuring the extender board
- `SoftConfig_xxx.c` for configuring the EZ-KIT Lite/EZ-Board; `xxx` identifies the EZ-KIT Lite/EZ-Board file in each example.

Page 2 of “[Video Decoder EI3 Extender Board Schematic](#)” on page B-1 shows how the GPIO expanders are connected to the board’s ICs.

U12 is a 24-bit bus switch. The switch connects the decoder to the processor.

U8-9 are 2-port bus switches. The switches select the GPIO signals to be used as the interrupt for the ADV7842 device (U10).

U18 is an 8-port bus switch. The switch is used to connect/disconnect the SPORT interface of the processor to the ADV7842 receiver.

[Table 2-1](#) and [Table 2-2](#) show the output signals of the GPIO expander (U2) with a TWI address of 0100 110 X , where X represents the read or write bit. The signals that control an individual FET have an entry under the **FET** column. The **Component Connected** column shows the board IC that is connected if the FET is enabled.

Table 2-1. Output Signals of GPIO Expander (U2 Port A)

Bit	Signal Name	Description	FET	Component Connected	Default
0	$\overline{24_BIT_ADV7842}$	24-bit video mode	U12	U10	OFF
1	Not Used				
2	$\overline{SPORT_ENABLE}$	Enable SPORT interface	U18	U10	OFF
3	Not Used				
4	Not Used				
5	Not Used				

Video Decoder EI3 Extender Board Hardware Reference

Table 2-1. Output Signals of GPIO Expander (U2 Port A) (Cont'd)

Bit	Signal Name	Description	FET	Component Connected	Default
6	Not Used				
7	Not Used				

Table 2-2. Output Signals of GPIO Expander (U2 Port B)

Bit	Signal Name	Description	FET	Component Connected	Default
0	ADV7842_INT_GPIO0	Decoder interrupt	U8	U10	OFF
1	$\overline{\text{ADV7842_INT_GPIO1}}$	Decoder interrupt	U8	U10	OFF
2	$\overline{\text{ADV7842_INT_GPIO2}}$	Decoder interrupt	U8	U10	OFF
3	$\overline{\text{ADV7842_INT_GPIO3}}$	Decoder interrupt	U8	U10	OFF
4	$\overline{\text{ADV7842_INT_GPIO4}}$	Decoder interrupt	U9	U10	OFF
5	$\overline{\text{ADV7842_INT_GPIO5}}$	Decoder interrupt	U9	U10	OFF
6	$\overline{\text{ADV7842_INT_GPIO6}}$	Decoder interrupt	U9	U10	OFF
7	$\overline{\text{ADV7842_INT_GPIO7}}$	Decoder interrupt	U9	U10	OFF

ADV7842_INT_GPIOx Signal

The $\overline{\text{ADV7842_INT_GPIOx}}$ signal connects the interrupt signal of the ADV7842 video decoder to one of eight GPIO pins of the processor. U2 ports GPB0-7 select the connection to the appropriate GPIO signal via the U8-9 bus switches.

SPORT_ENABLE Signal

The SPORT_ENABLE signal connects the audio signal of the ADV7842 video decoder to the SPORT interface of the processor. U2 port GPA2 enables or disables the connection via the U18 bus switch. By default, the audio is disabled.

Connectors

This section describes connector functionality and provides info about mating connectors. The connector locations are shown in [Figure 2-6](#).

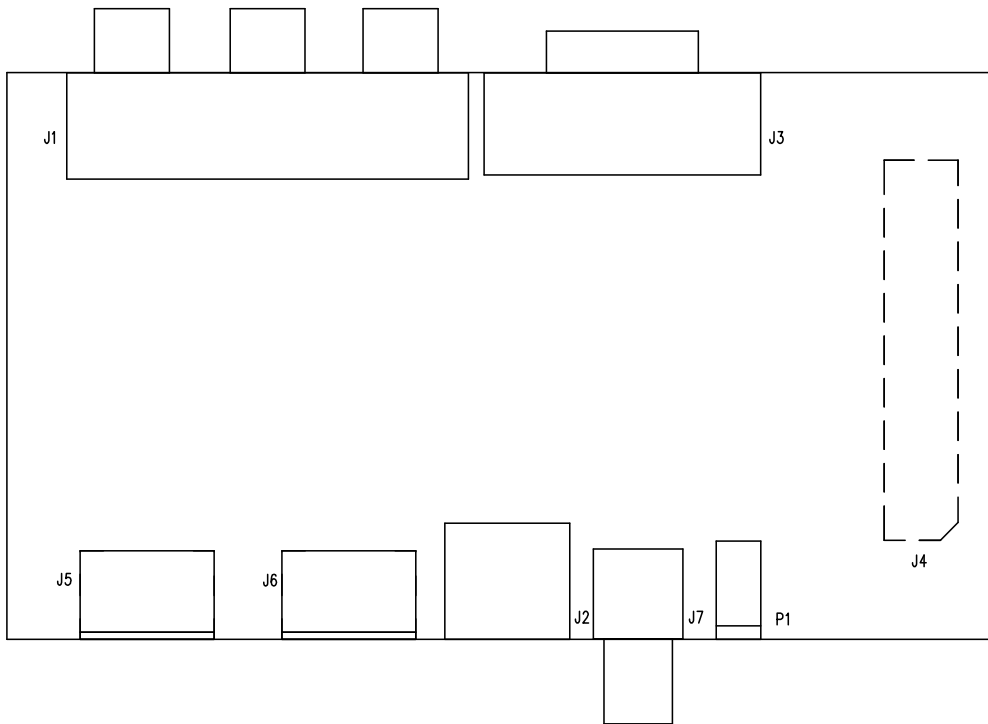

Figure 2-6. Connector Locations



Connectors denoted by a dotted line are located on the opposite side of the board.

Component Connector (J1)

The component connector (J1) is a group of three RCA jacks which connect to the ADV7842 video decoder. The connector can be used for YPrPb and RGB modes and supports SD, ED, and HD video modes.

Part Description	Manufacturer	Part Number
Component (3x1 RCA)	CUI	RCJ-32265
Mating Cable		
Component cable	BELKIN	AV21000-06

S-Video Connector (J2)

The S-Video connector (J2) is a DIN connector to the ADV7842 video decoder. The connector can be used for Y-C mode and supports SD, ED, and HD video modes.

Part Description	Manufacturer	Part Number
S-Video	CUI	MD-40SM
Mating Cable		
S-Video cable	BELKIN	F8V308-06

VGA Connector (J3)

The VGA connector (J3) is a DSUB15 connector which connects to the ADV7842 video decoder. The connector can be used for RGB mode and supports SD, ED, and HD video modes.

Part Description	Manufacturer	Part Number
VGA	EDAC	634-015-263-032

Connectors

Part Description	Manufacturer	Part Number
Mating Cable		
VGA cable	BELKIN	F2N028-06

Expansion Interface III (EI3) Connectors (J4)

One board-to-board connector (J4) provides signals from the PPI, SPORT, TWI, and GPIO interfaces of the processor. The connector is located on the top side of the board.

Part Description	Manufacturer	Part Number
120-pin, 0.6 mm	HIROSE	FX8-120S-SV(21)
Mating Connector		
120-pin, 0.6 mm	HIROSE	FX8-120P-SV1(91)

HDMI Connector (J5-6)

The HDMI connectors (J5-6) are HDMI receptacles connected to the ADV7842 video decoder. The connector can be used for YCbCr and RGB modes and supports SD, ED, and HD video modes. It supports ARC and is v.1.4 compliant.

Part Description	Manufacturer	Part Number
HDMI	FCI	10029449-002TLF
Mating Cable		
HDMI cable	MEDIABRIDGE	91-02X-06B

Composite Connector (J7)

The composite connector (J7) is a single RCA jack connected to the ADV7842 video decoder. The connector can be used for CVBS and supports SD, ED, and HD video modes.

Part Description	Manufacturer	Part Number
Composite (1 RCA)	SWITCHCRAFT	PJ1RAN1X1U01X
Mating Cable		
Composite Cable	KOBICONN	17FH101

Power Connector (P1)

Under normal circumstances, the power connector is not needed because the Video Decoder EI3 Extender Board derives its power from the EZ-KIT Lite/EZ-Board. If the EZ-KIT Lite/EZ-Board is not able to supply enough power to the Video Decoder EI3 Extender Board, then an external power supply can be connected to P1 and power the extender and EZ-KIT Lite/EZ-Board.

Part Description	Manufacturer	Part Number
0.65 mm power jack	CUI	045-0883R
Mating Cable		
5.0VDC@3.6A power supply	GLOBETEK	GS-1750(R)

LEDs

LEDs

This section describes the on-board LEDs.

HDMI Detect LED (LED1–2)

When LED1 or LED2 is lit solid (yellow), it indicates that a valid connection is sensed on the HDMI connector.

Power LED (LED3)

When LED3 is lit solid (green), it indicates that power is being supplied to the board properly.

A VIDEO DECODER EI3 EXTENDER BOARD BILL OF MATERIALS

The bill of materials corresponds to “[Video Decoder EI3 Extender Board Schematic](#)” on page B-1.

Ref.	Qty.	Description	Reference Designator	Manufacturer	Part Number
1	2	SN74LVC1G125 SOT23-5	U21-U22	TI	74LVC1G125DBVRE4
2	1	SN74CB3Q16211 TSSOP56	U12	DIGI-KEY	296-17629-1-ND
3	1	SN74AVC4T245 SOIC16	U7	DIGI-KEY	296-17930-1-ND
4	1	SST25WF040 SOIC8	U13	SST	SST25WF040-40-5I-SAF
5	1	SN74AVC8T245 TSSOP24	U18	TI	SN74AVC8T245PW
6	1	K4H561638J TSOP66_22P2X11 P76X0P32MM	U16	SAMSUNG	K4H561638N-LCB3000
7	1	28.6363MHZ OSCJ850P1140X4 70-4	Y1	DIGI KEY	300-8572-1-ND
8	1	12MHZ OSC015	U26	DIGI KEY	535-9413-2-ND
9	1	MCP23017 QFN65P600X600- 29	U2	DIGI KEY	MCP23017-E/ML-ND
10	2	PI3C3125 TSSOP14	U8-U9	PERICOM	PI3C3125

Ref.	Qty.	Description	Reference Designator	Manufacturer	Part Number
11	1	74AVC24T245 LFBGA84	U6	DIGI KEY	296-17662-1-ND
12	1	ADP1706-3.3V LFCSP8	VR1	ANALOG DEVICES	ADP1706ACPZ-3.3-R7
13	3	ADP1715 MSOP8	VR2-VR4	ANALOG DEVICES	ADP1715ARMZ-1.8-R7
14	1	ADP1715 MSOP8	VR5	ANALOG DEVICES	ADP1715ARMZ-2.5-R7
15	1	ADV7842 BGA256C100P16 X16_1700X1700	U10	ANALOG DEVICES	ADV7842KBCZ-5
16	1	RCA 1X1 CON012	J7	SWITCH- CRAFT	PJ1RAN1X1U01X
17	1	PWR .65MM CON027	P1	DIGI-KEY	CP1-022PJCT-ND
18	1	1A RESETABLE 1206	F1	RAYCHEM	NANOSMDC110F-2
19	1	DSUB 15P EDAC_634-015-2 63-032	J3	MOUSER	587-634-015-263-032
20	2	HDMI 19P FCI_10029449-00 2TLF	J5-J6	FCI	10029449-002LF
21	1	RCA 3X1 CUI-STACK_RCJ- 32265	J1	DIGI KEY	CP-1446-ND
22	1	MINI-DIN 4PIN CUI-STACK_MD- 40SM	J2	DIGI KEY	CP-2240-ND
23	1	.6MM 120PIN HIROSE_FX8-120 S-SV(21)	J4	HIROSE	FX8-120S-SV(21)

Video Decoder EI3 Extender Board Bill Of Materials

Ref.	Qty.	Description	Reference Designator	Manufacturer	Part Number
24	3	10K 1/10W 5% 0805	R11,R15-R16	VISHAY	CRCW080510K0JNEA
25	3	10K 1/10W 5% 0805	R9-R10,R17	VISHAY	CRCW080510K0JNEA
26	2	10K 31MW 5% RNET8	RN16-RN17	CTS	746X101103JP
27	31	0.1UF 10V 10% 0402	C5-C6,C11,C15-C19,C21-C22,C24-C26,C44,C58,C66,C68,C77,C80-C87,C90-C94	AVX	0402ZD104KAT2A
28	31	0.01UF 16V 10% 0402	C29-C37,C42-C43,C45-C48,C50-C51,C54,C57,C59-C65,C67,C69-C72	AVX	0402YC103KAT2A
29	1	10K 1/16W 5% 0402	R55	VISHAY	CRCW040210K0FKED
30	7	4.7K 1/16W 5% 0402	R45-R46,R51-R52,R57,R60-R61	VISHAY	CRCW04024K70JNED
31	2	0 1/16W 5% 0402	R1-R2	PANASONIC	ERJ-2GE0R00X
32	6	0 1/16W 5% 0402	R4,R6,R8,R26-R28	PANASONIC	ERJ-2GE0R00X
33	3	33 1/16W 5% 0402	R3,R5,R56	VISHAY	CRCW040233R0JNEA
34	9	24.0 1/10W 1% 0603	R30,R32,R34-R35,R38-R41,R43	DIGI-KEY	311-24.0HRTR-ND
35	2	4.7UF 6.3V 20% 0603	C55-C56	AVX	06036D475MAT2A
36	1	1UF 6.3V 20% 0402	C78	PANASONIC	ECJ-0EB0J105M
37	4	100 1/16W 5% 0402	R12-R14,R54	DIGI-KEY	311-100JRTR-ND
38	2	27PF 50V 5% 0402	C96-C97	AVX	04025A270JAT2A

Ref.	Qty.	Description	Reference Designator	Manufacturer	Part Number
39	1	10UF 10V 10% 0805	C95	PANASONIC	ECJ-2FB1A106K
40	1	GREEN LED001	LED3	PANASONIC	LN1361CTR
41	1	430 1/16W 1% 0402	R50	DIGI-KEY	311-430LRCT-ND
42	2	47.0K 1/16W 1% 0402	R18,R21	ROHM	MCR01MZPF4702
43	2	47.0K 1/16W 1% 0402	R19-R20	ROHM	MCR01MZPF4702
44	4	1.0K 1/16W 1% 0402	R22-R23,R53,R59	PANASONIC	ERJ-2RKF1001X
45	13	2.2UF 25V 10% 0805	C1-C4,C27-C28, C38-C41,C49,C52- C53	DIGI KEY	445-6860-2-ND
46	3	1A MBR130LSFT1G SOD-123FL	D1-D3	ON SEMI	MBR130LSFT1G
47	9	51.1 1/16W 1% 0402	R31,R33,R36-R37, R42,R44,R47-R49	DIGI-KEY	541-51.1LCT-ND
48	1	27K 1/16W 5% 0402	R29	PANASONIC	ERJ-2GEJ273X
49	2	1000PF 50V 5% 0402	C20,C23	DIGI-KEY	490-3244-1-ND
50	5	22 1/16W 5% RNS003	RN11-RN15	PANASONIC	EXB-2HV220JV
51	2	220.0 1/10W 1% 0603	R24-R25	DIGI-KEY	P220HTR-ND
52	2	GREEN 0603	LED1-LED2	DIGI KEY	475-1409-2-ND
53	4	4700PF XXX 2A FIL_NFE61PT	FER1-FER4	DIGI KEY	490-2554-2-ND
54	9	75 1/16W 5% RESCAV_YC164-8	RN1-RN2,RN4- RN10	YAGEO	YC164-JR-0775RL

Video Decoder EI3 Extender Board Bill Of Materials

Ref.	Qty.	Description	Reference Designator	Manufacturer	Part Number
55	4	5A RCLAMP0524 DIO_RCLAMP05 24	D7-D10	SEMTECH	RCLAMP0524P.TCT
56	2	6A RCLAMP0504 DIO_RCLAMP05 04	D4-D5	SEMTECH	RCLAMP0504P.TCT
57	1	30MA DB3X314 DIO_DB3X314	D6	PANASONIC	DB3X314K0L
58	1	499 1/10W 1% 0402	R58	PANASONIC	ERJ-2RKF4990X
59	1	75.0 1/10W 1% 0402	R7	PANASONIC	ERJ-2RKF75R0X

Video Decoder EI3 Extender Board Schematic

	ANALOG DEVICES	20 Cotton Road Nashua, NH 03063 PH: 1-800-ANALOGD
Title	Video Decoder EI3 Extender Board Title Page	
Size C	Board No. A0253-2010	Rev 1.0
Date	3/7/12	Sheet 1 of 9

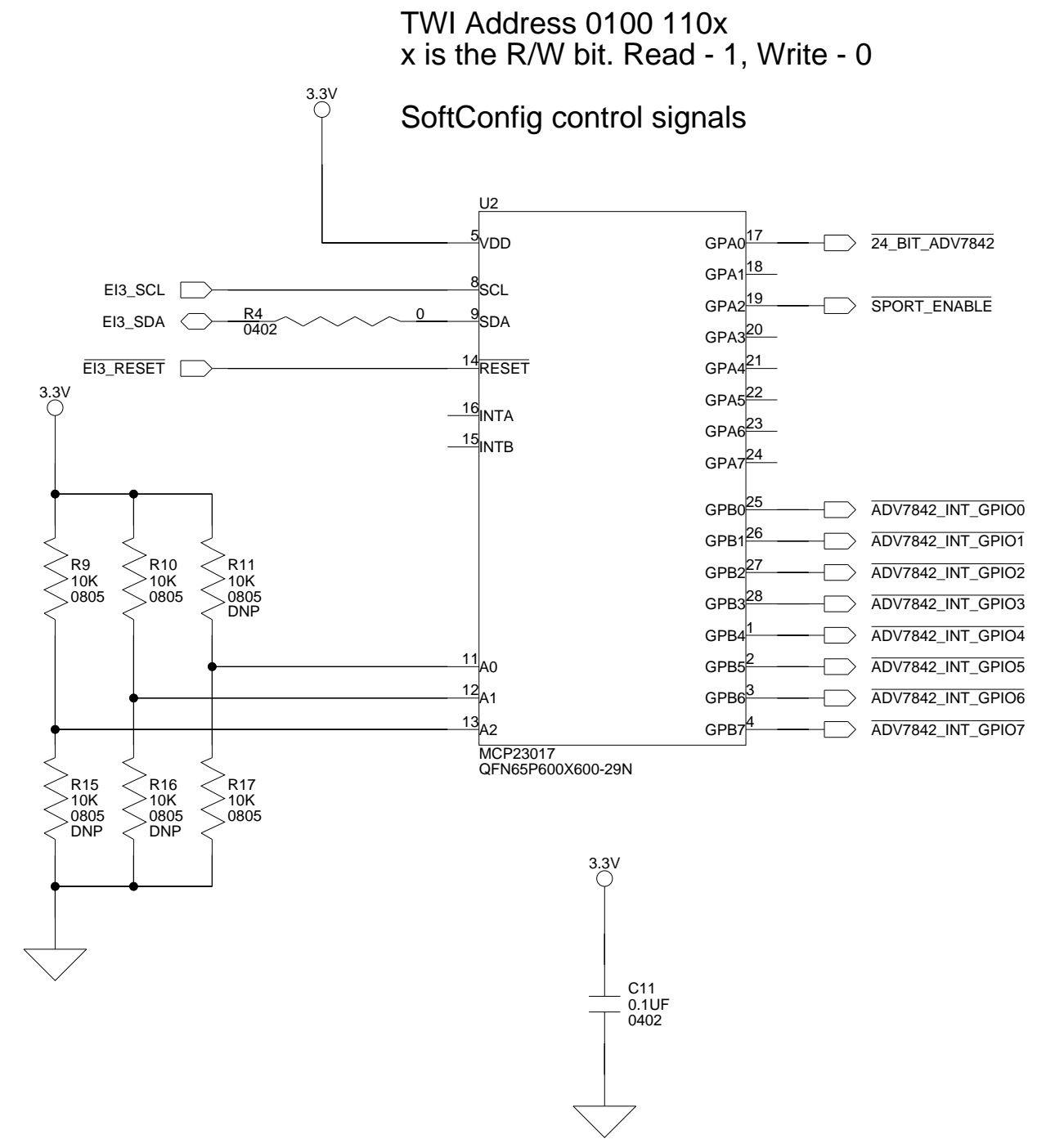
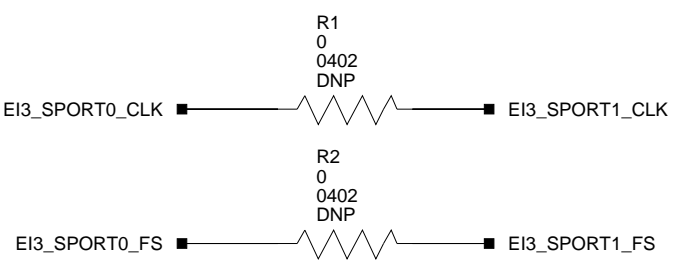
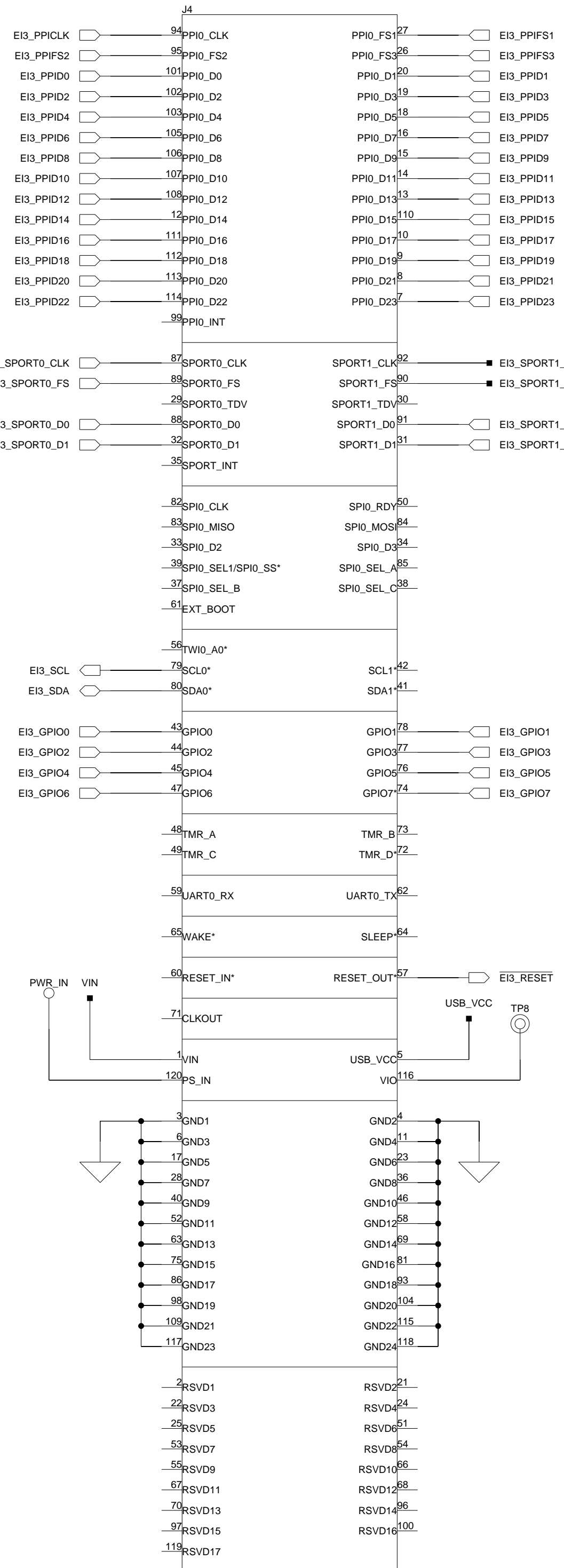

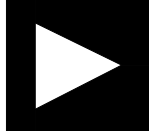
 ANALOG DEVICES		20 Cotton Road Nashua, NH 03063 PH: 1-800-ANALOGD	
		Title Video Decoder EI3 Extender Board EI3 Connector/GPIO Extender	
Size C	Board No. A0253-2010	Rev 1.0	
Date 3/7/12	Sheet 2 of 9		

A

B

C

D

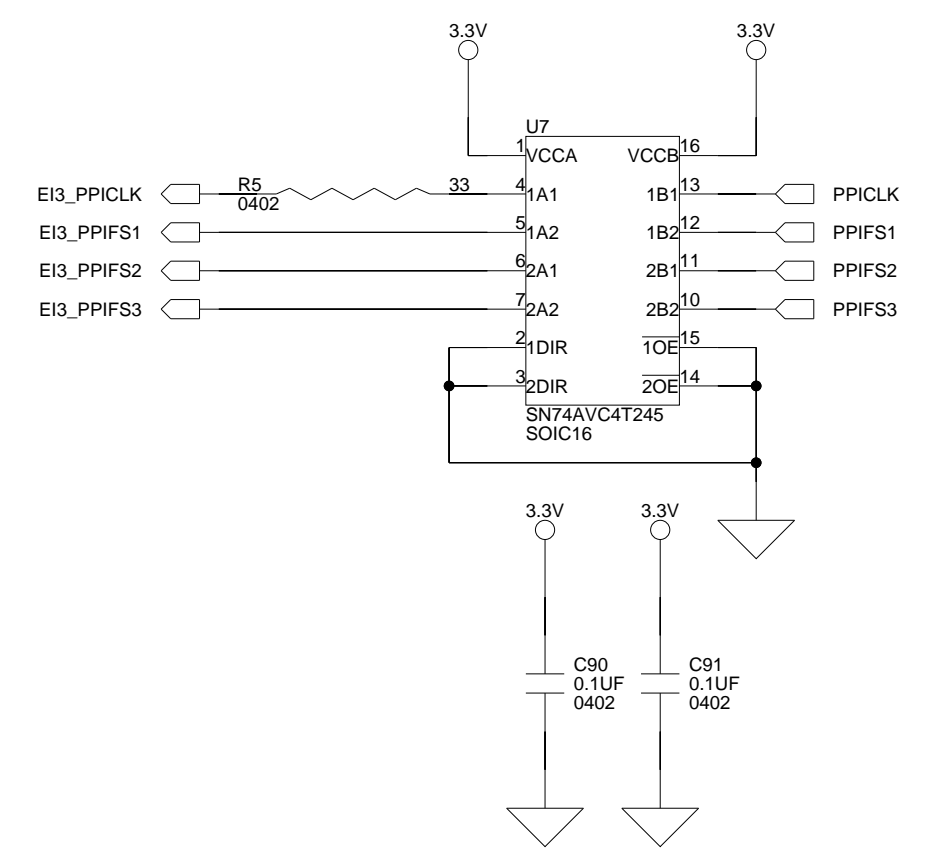
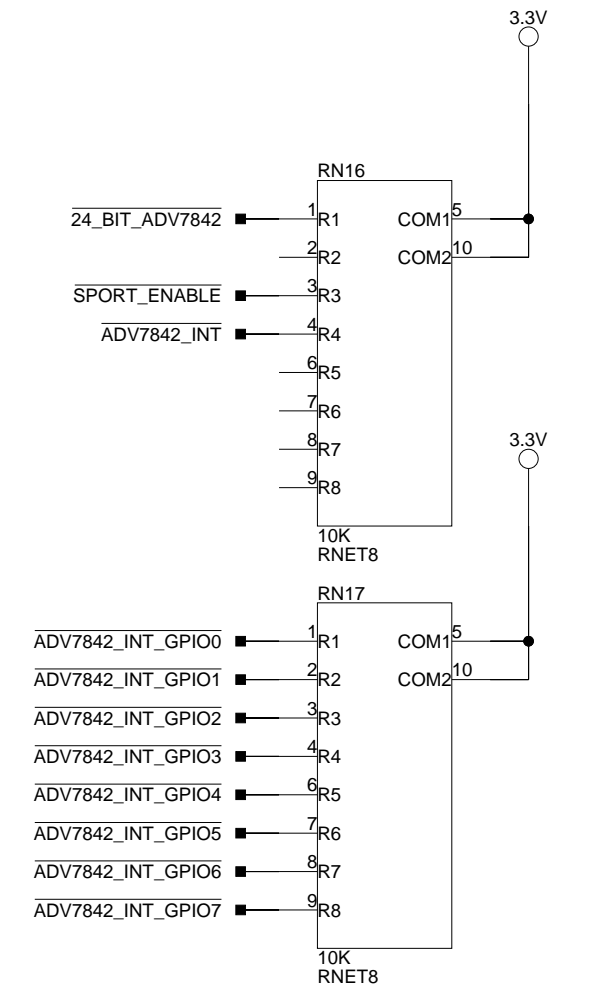
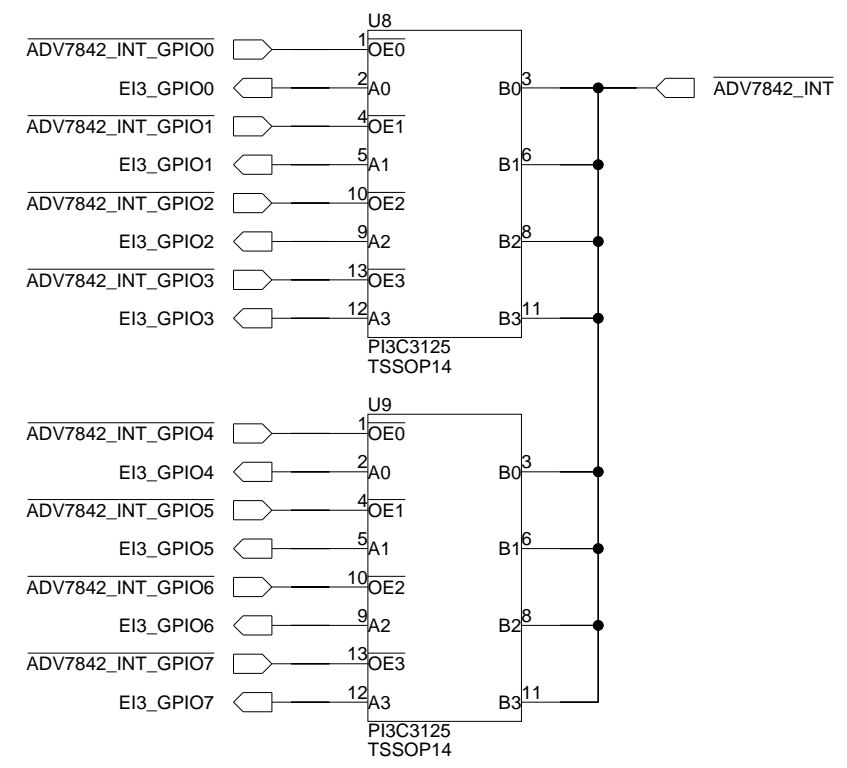
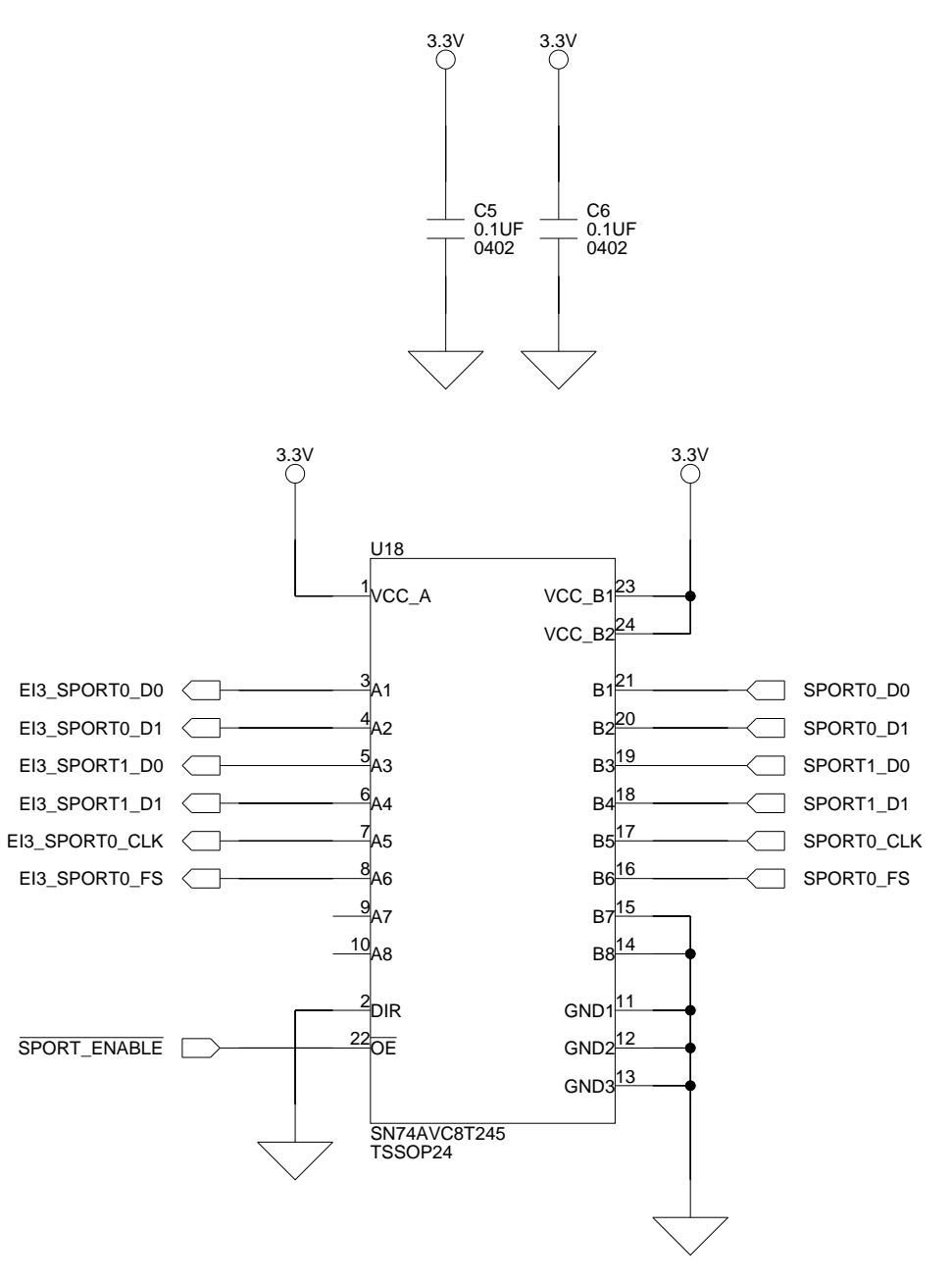
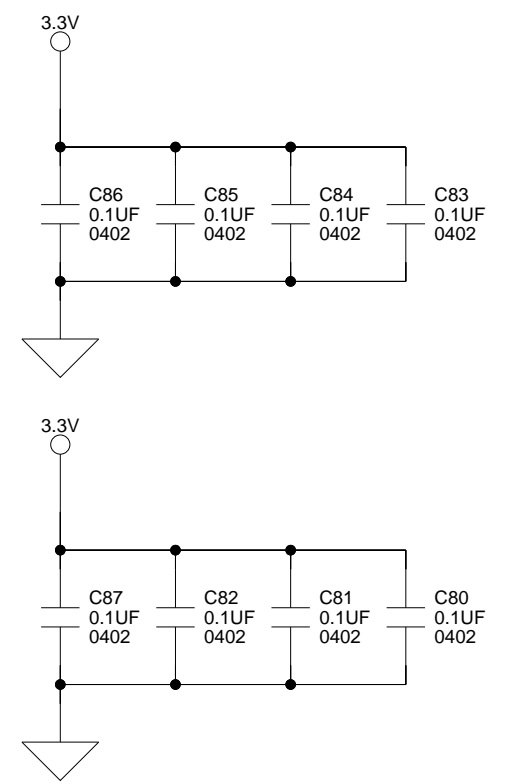
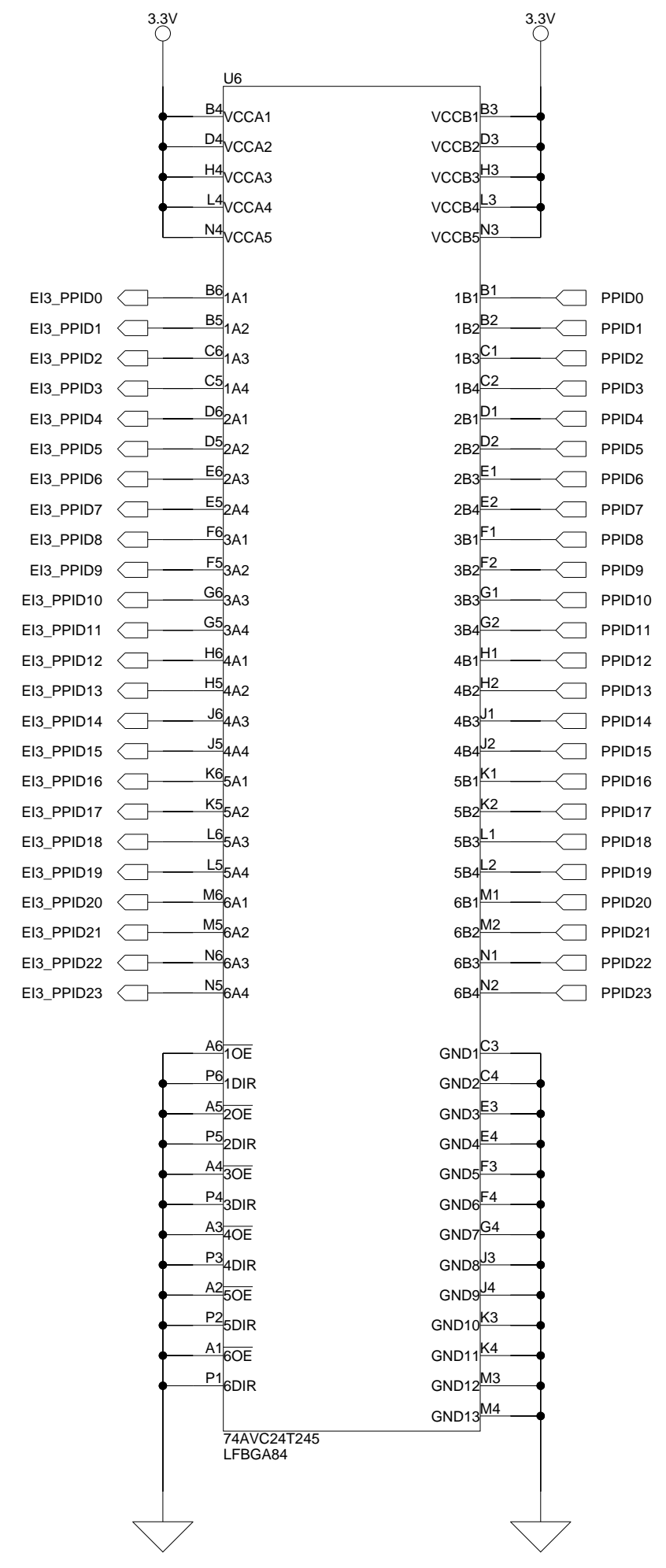

		20 Cotton Road Nashua, NH 03063 PH: 1-800-ANALOGD	
		Title Video Decoder E13 Extender Board Buffers/SoftConfig	
Size C	Board No. A0253-2010	Rev 1.0	
Date 3/7/12	Sheet 3 of 9		

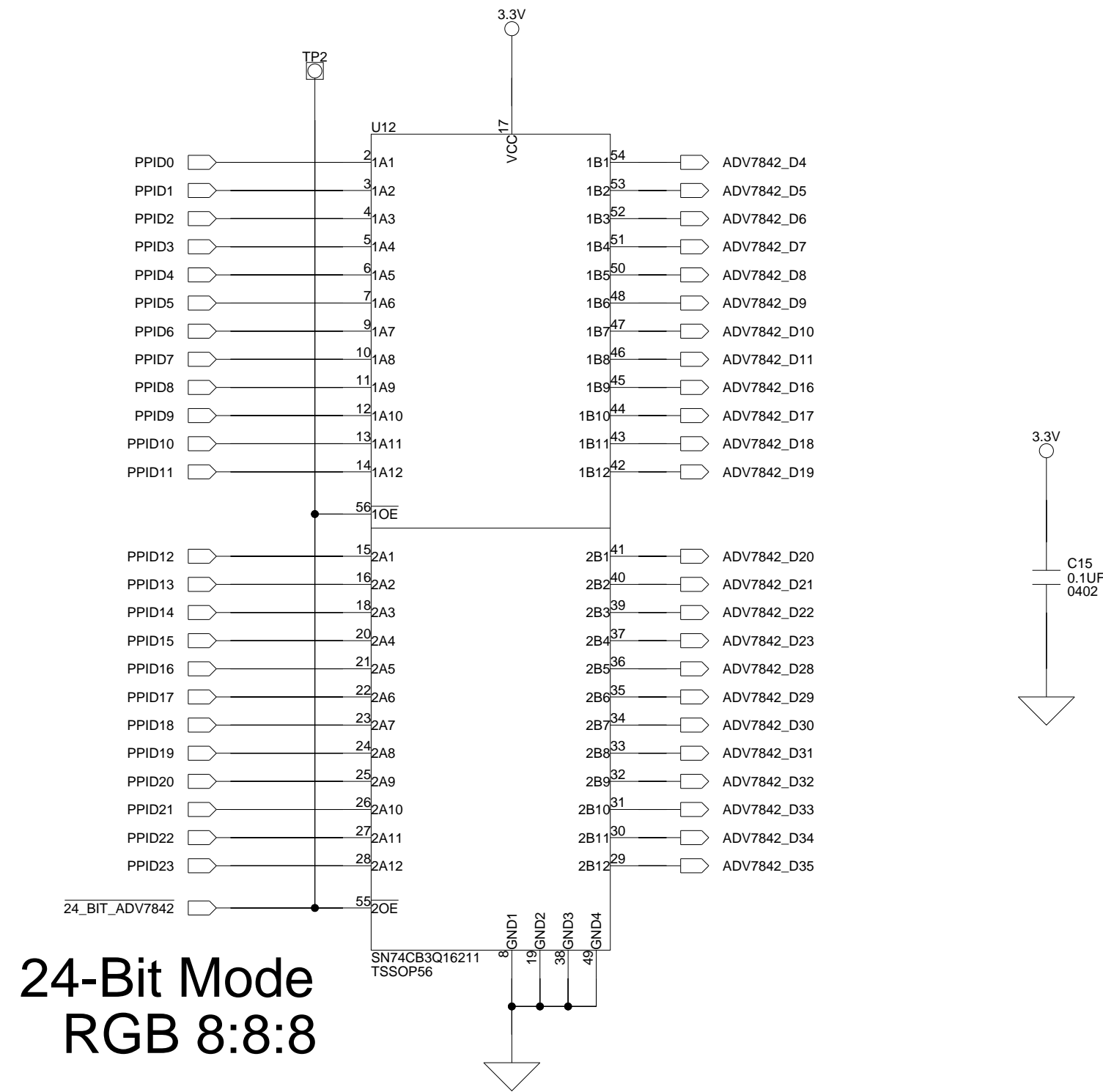

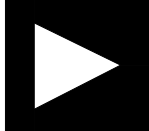
 ANALOG DEVICES		20 Cotton Road Nashua, NH 03063 PH: 1-800-ANALOGD
Title Video Decoder EI3 Extender Board Video Mode		
Size C	Board No. A0253-2010	Rev 1.0
Date 3/7/12	Sheet 4 of 9	

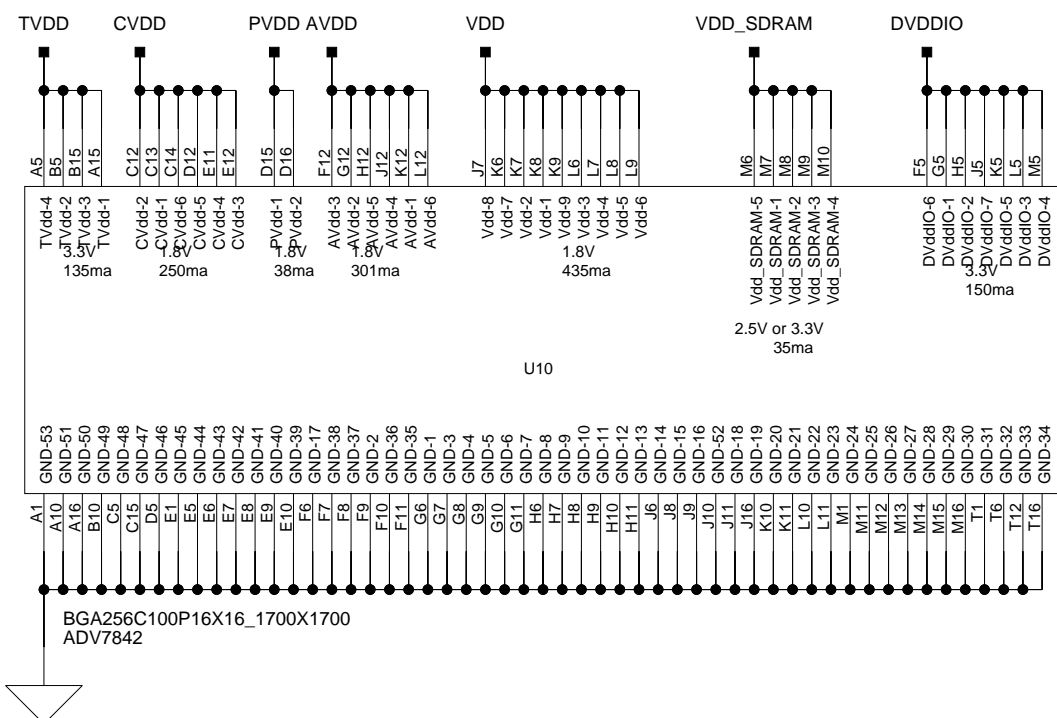

TWI Address 0100 000x
x is the R/W bit. Read - 1, Write - 0

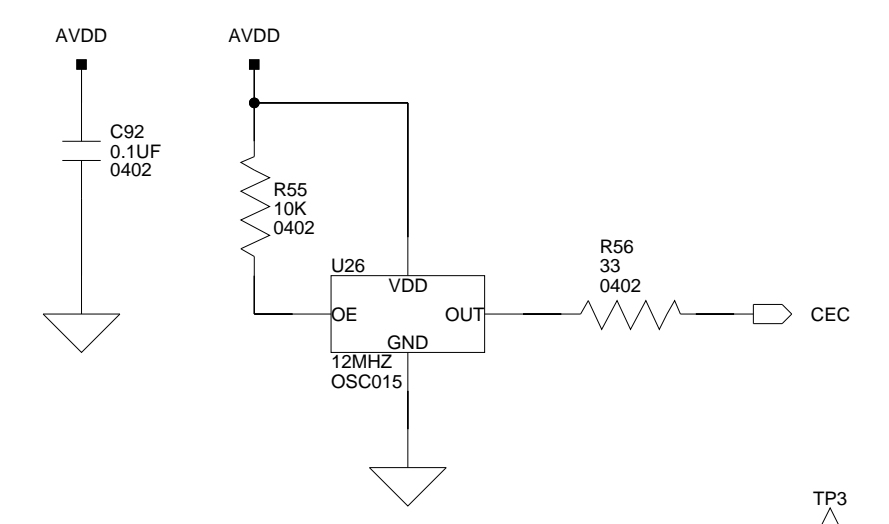
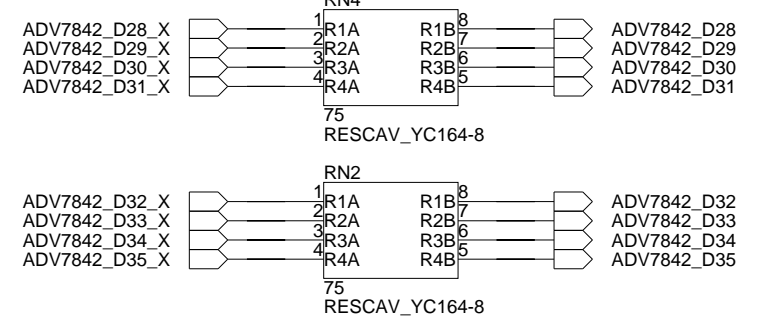
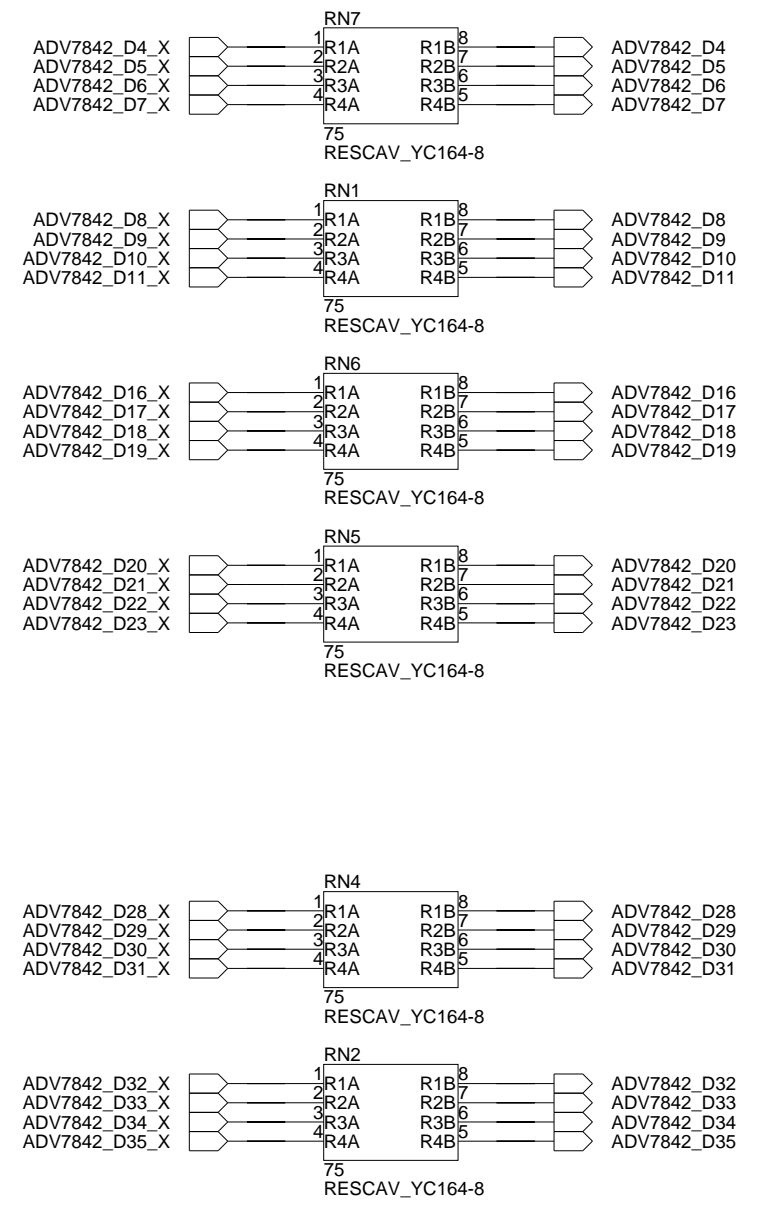
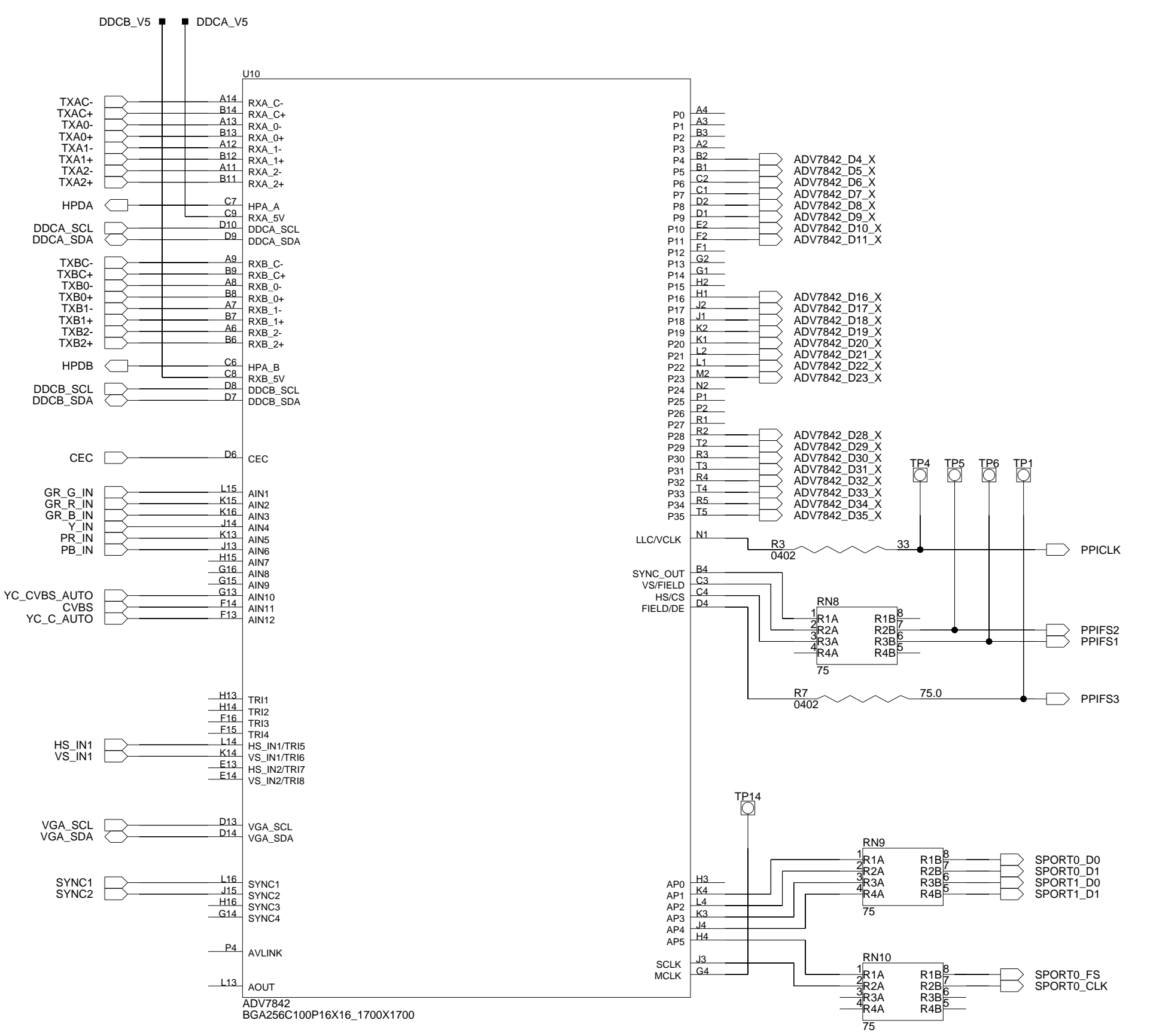

		20 Cotton Road Nashua, NH 03063 PH: 1-800-ANALOGD	
		Title Video Decoder EI3 Extender Board ADV7842	
Size C	Board No.	A0253-2010	Rev
Date	3/7/12	Sheet	5 of 9

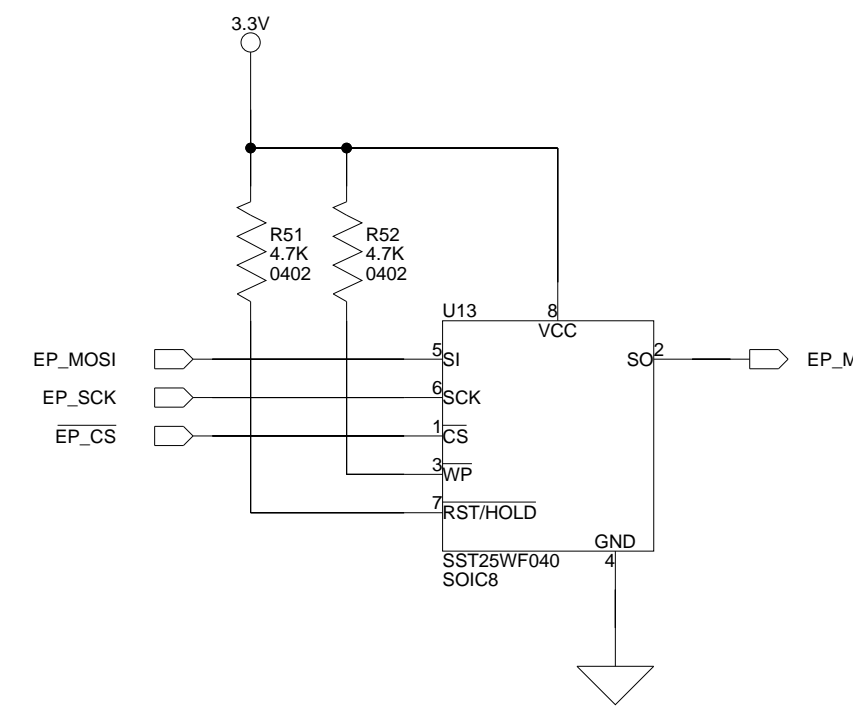
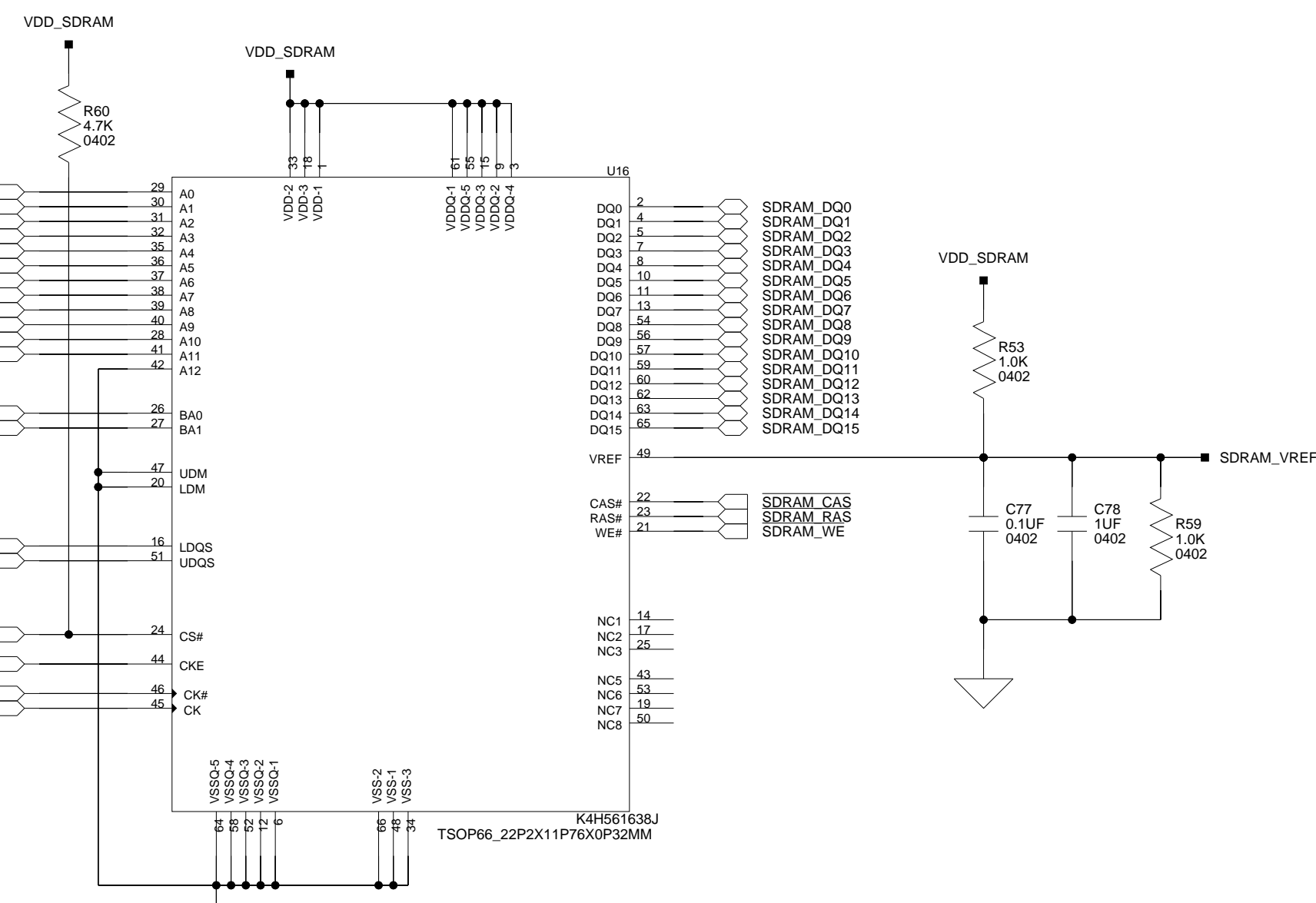
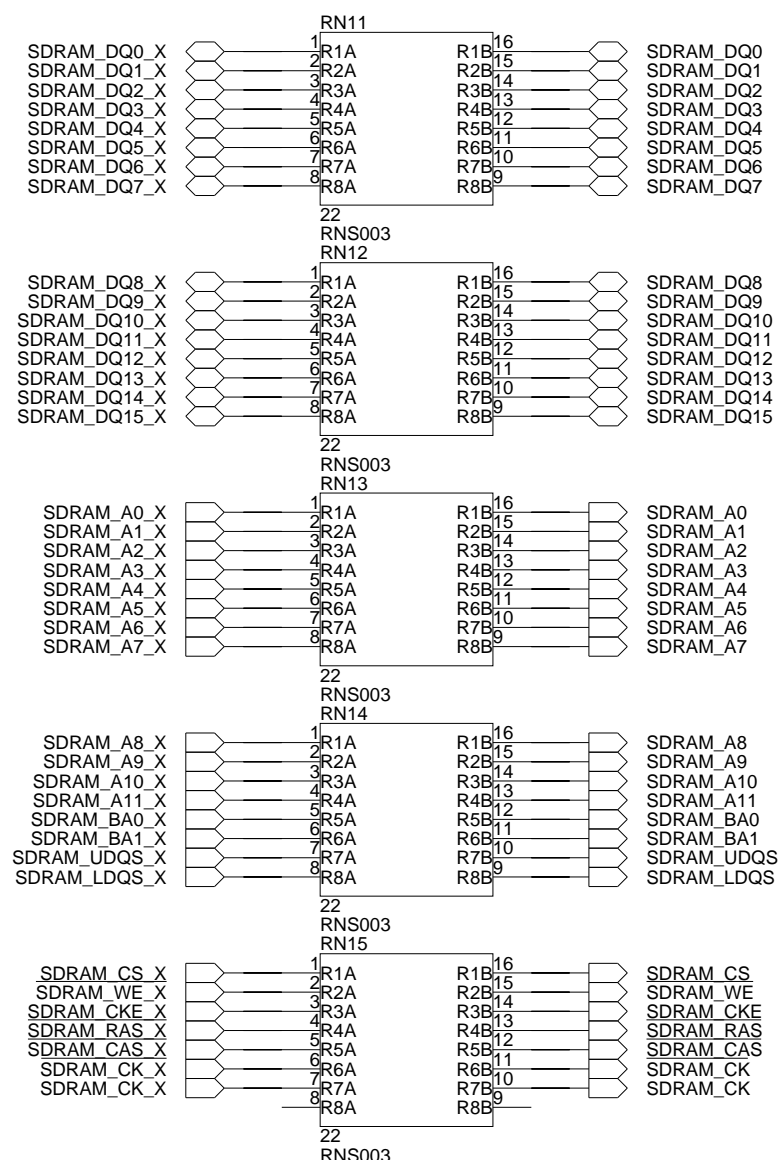
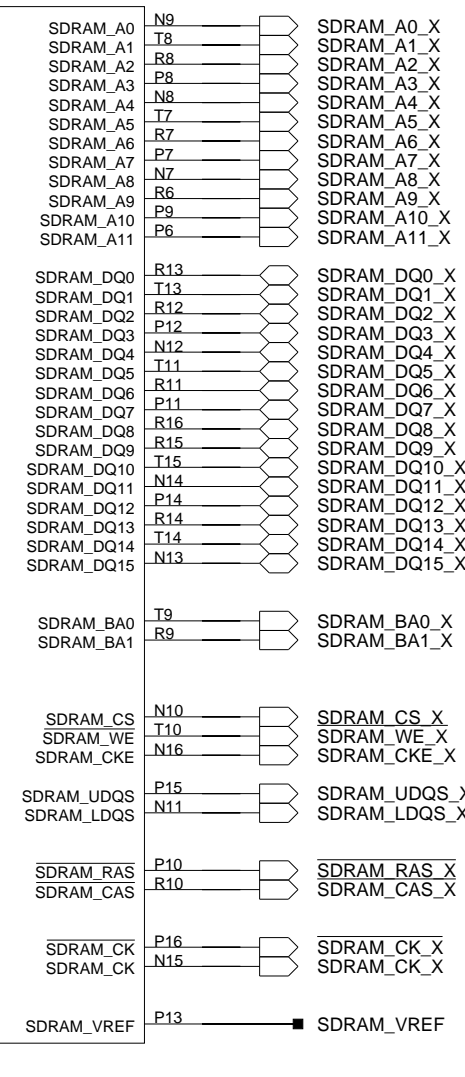
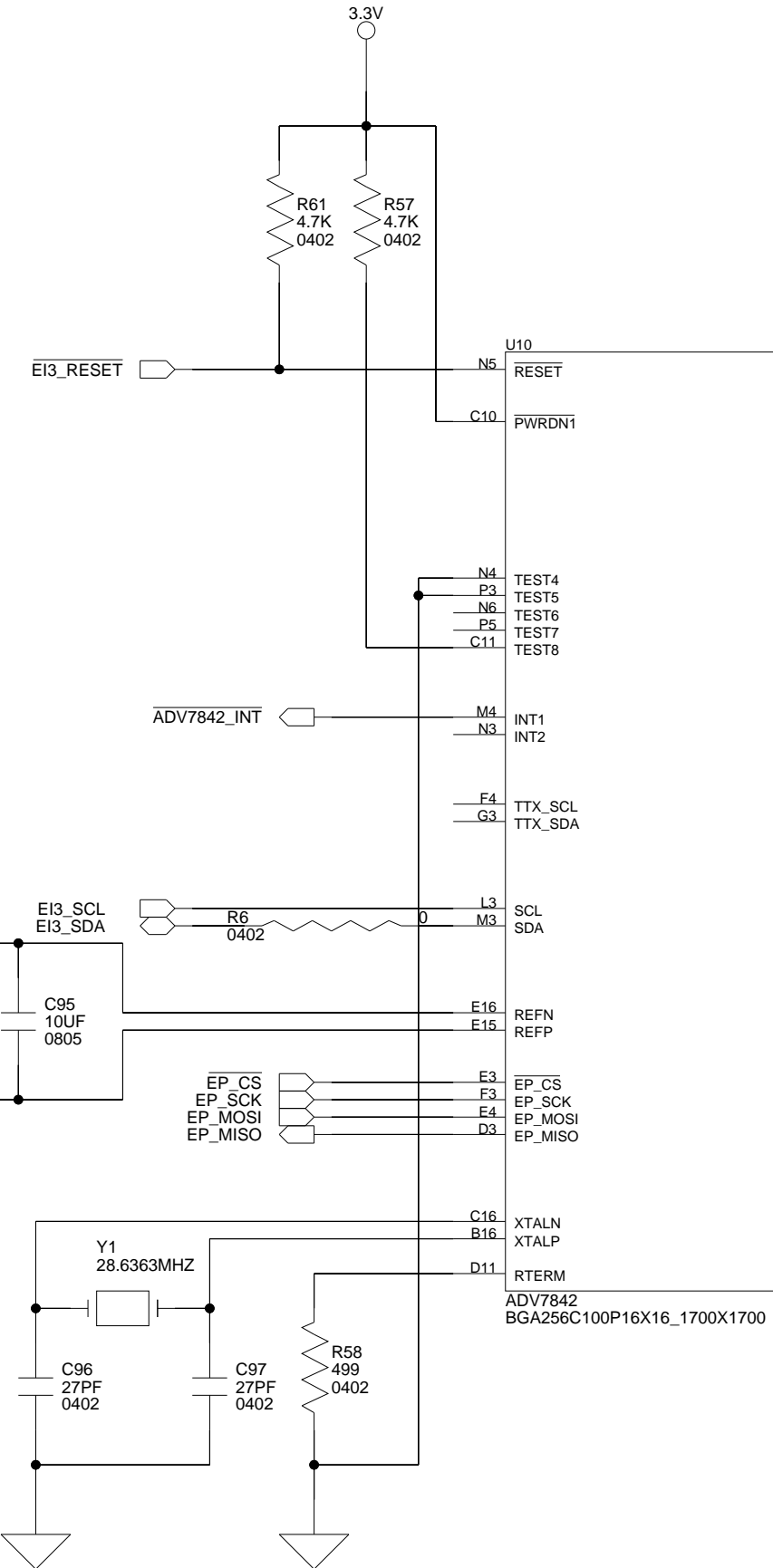

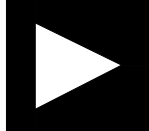
 ANALOG DEVICES		20 Cotton Road Nashua, NH 03063 PH: 1-800-ANALOGD	
		Title Video Decoder EI3 Extender Board ADV7842 Memory	
Size C	Board No. A0253-2010	Rev 1.0	
Date 3/7/12	Sheet 6 of 9		

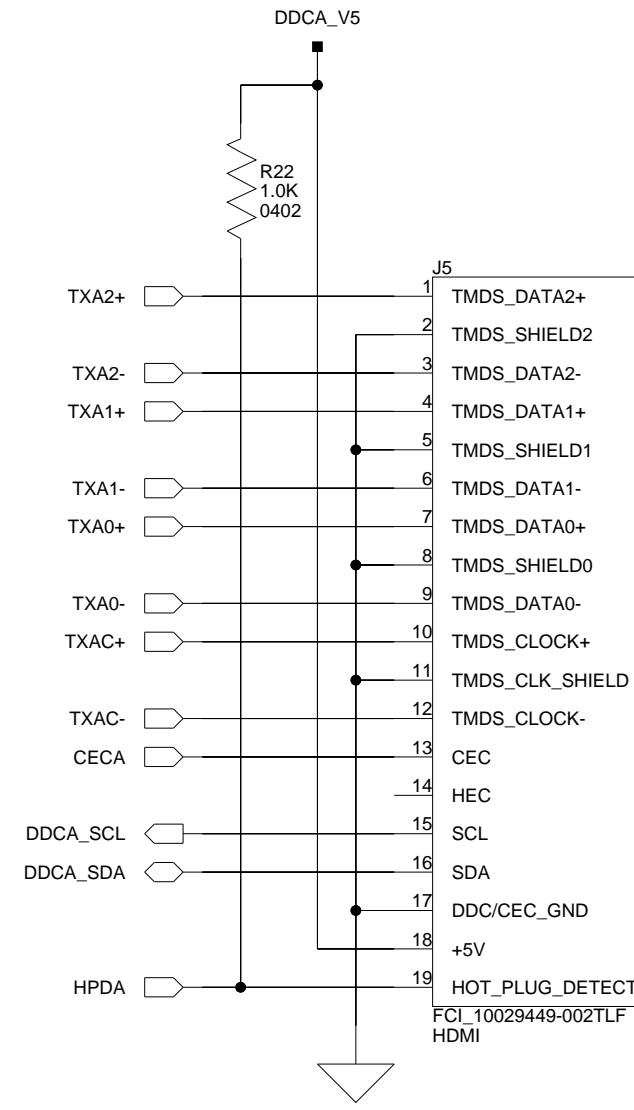

HDMI

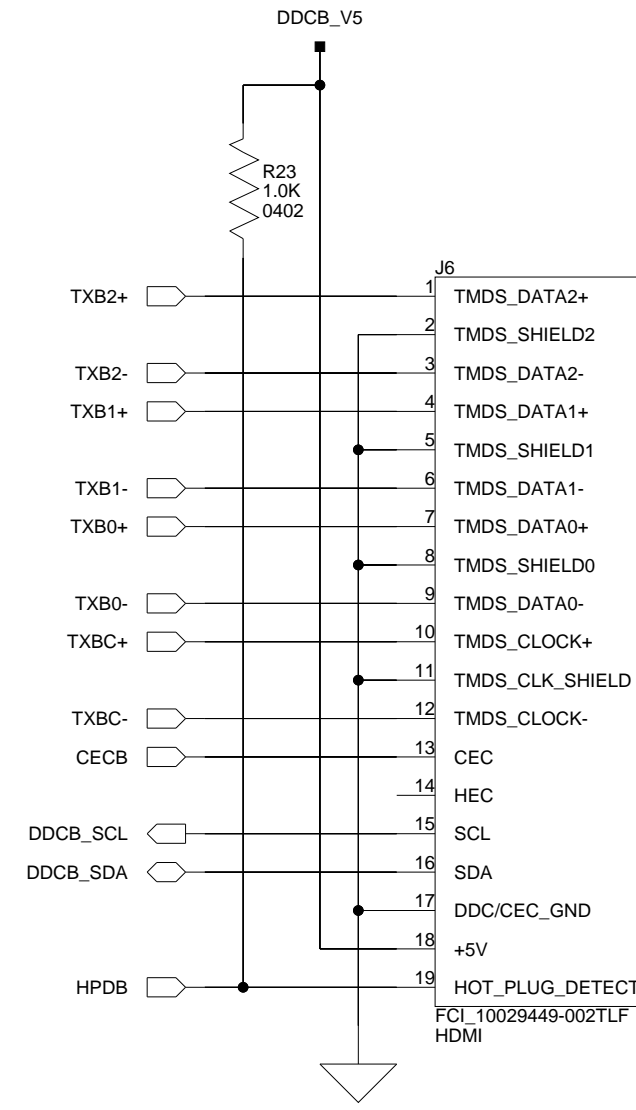
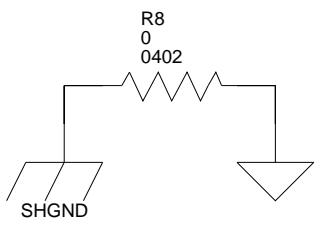

HDMI

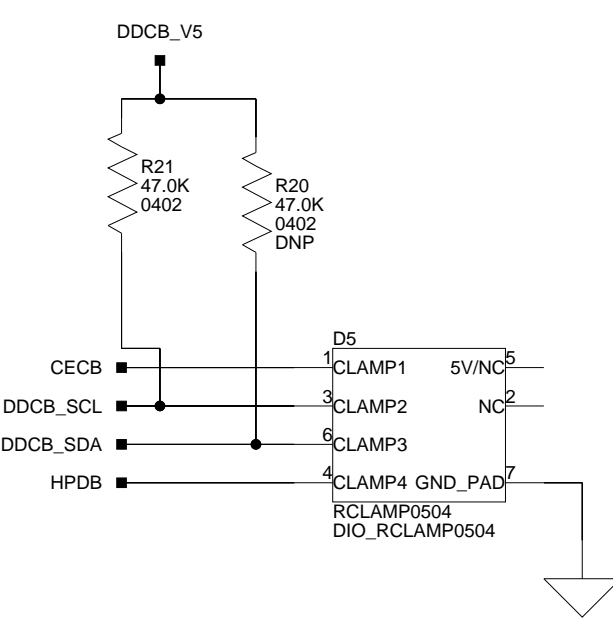
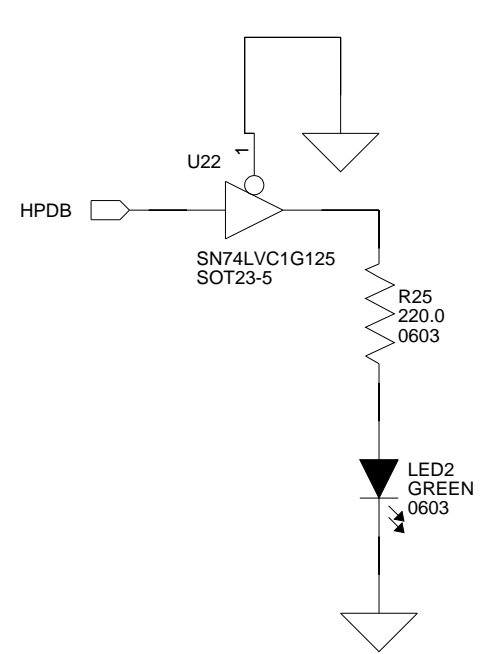
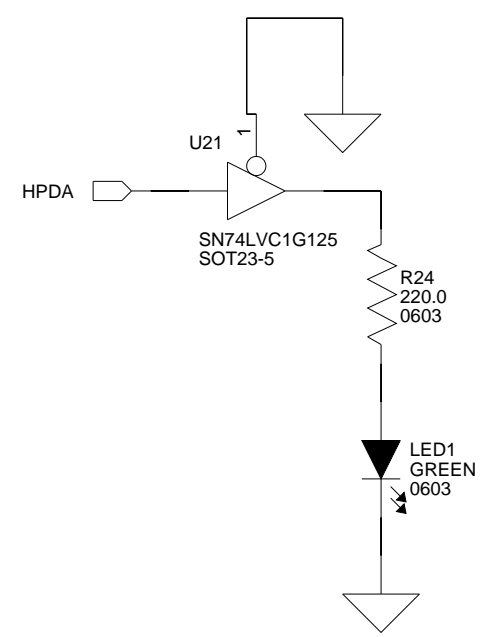
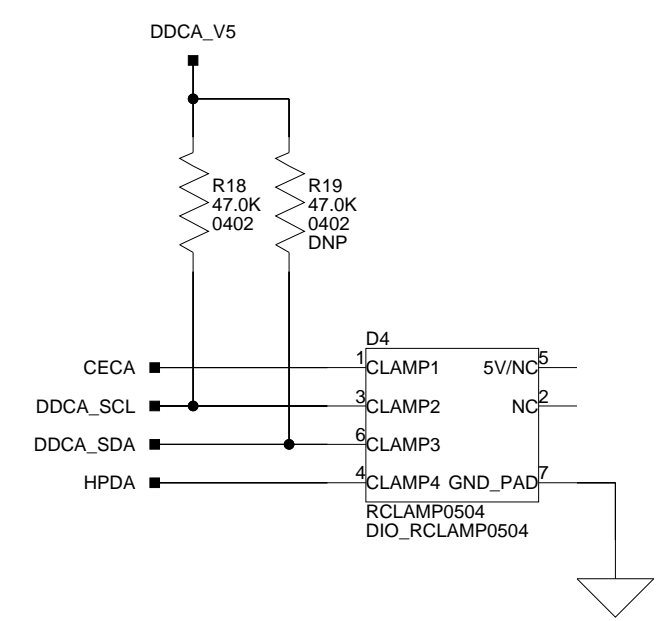
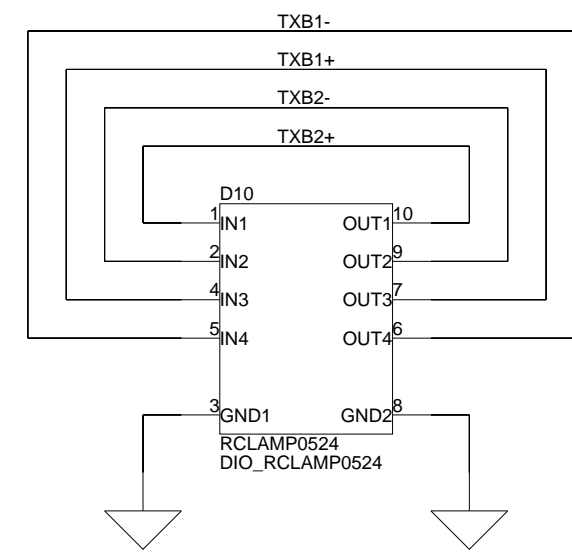
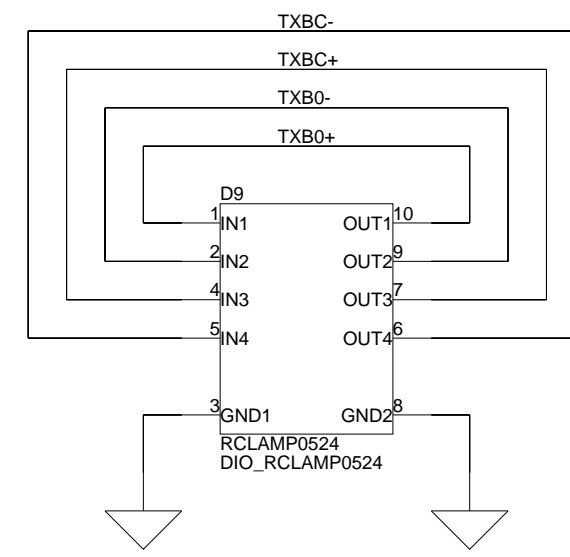
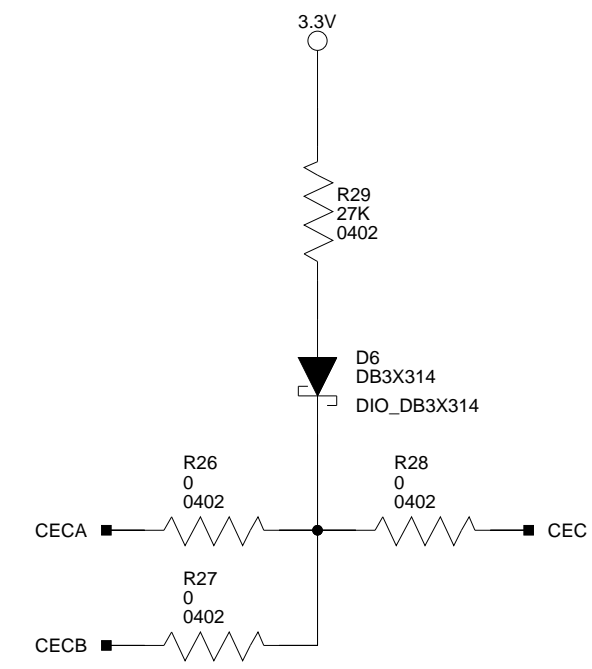
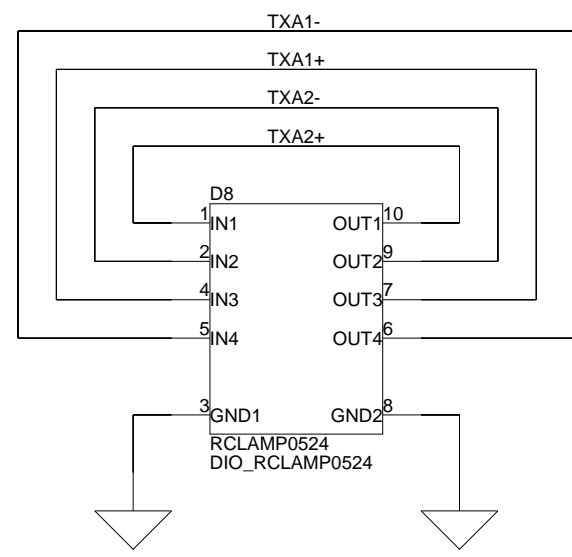
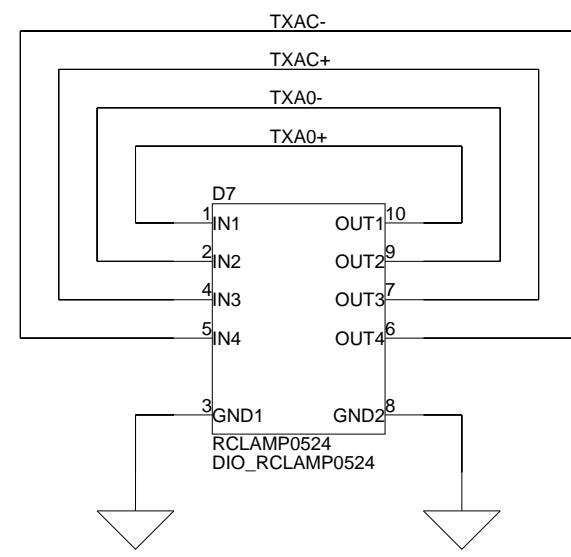

		20 Cotton Road Nashua, NH 03063 PH: 1-800-ANALOGD	
Title Video Decoder EI3 Extender Board Video Connectors			
Size C	Board No. A0253-2010	Rev 1.0	
Date	3/7/12	Sheet	7 of 9

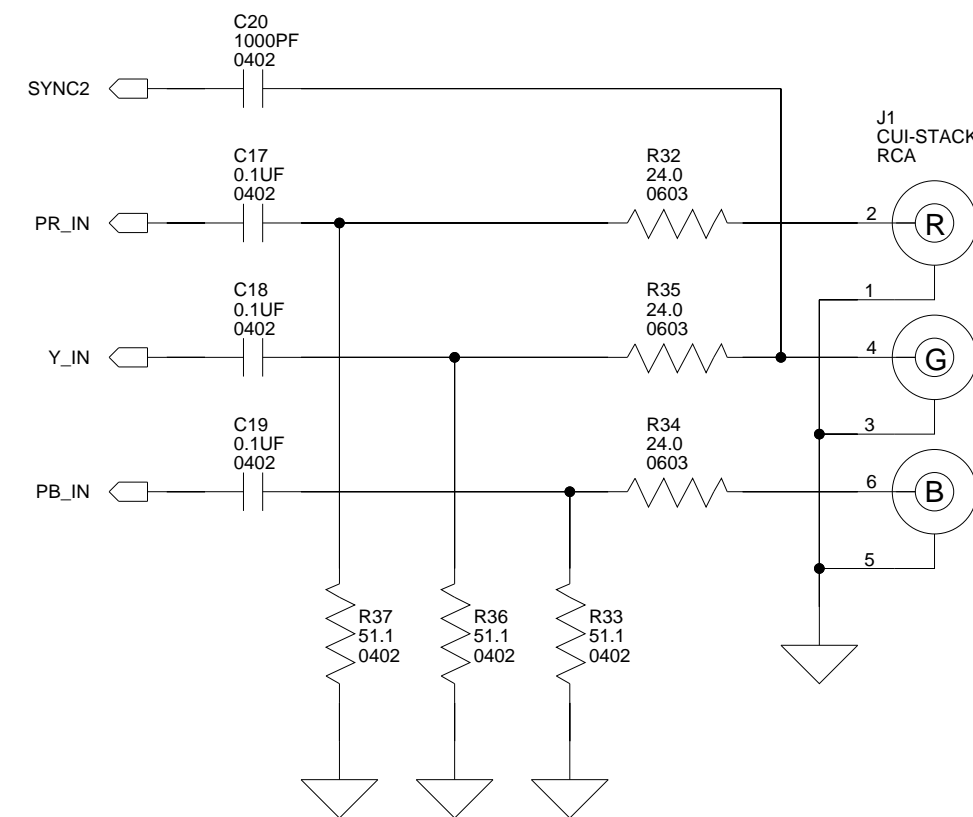

Component

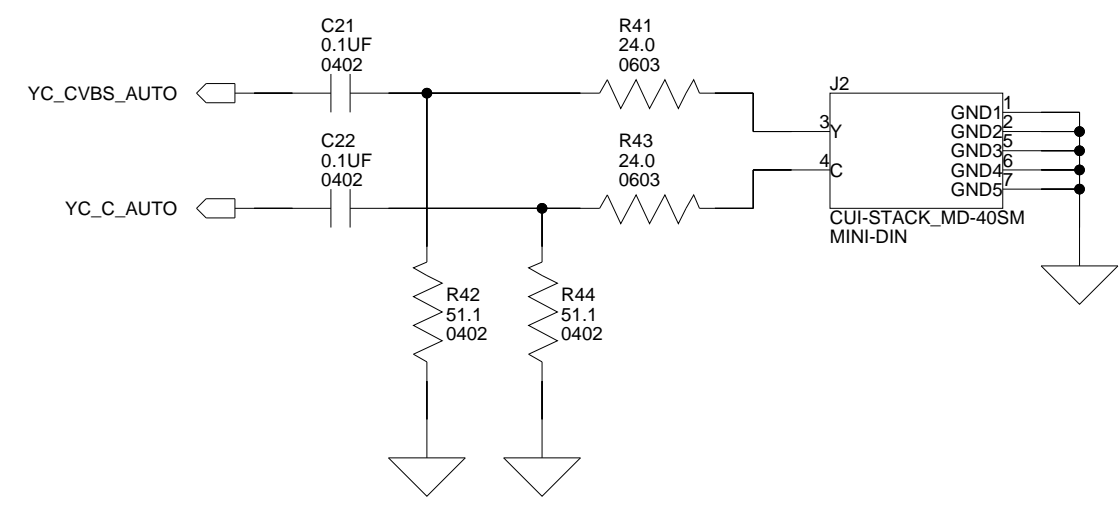

S-Video

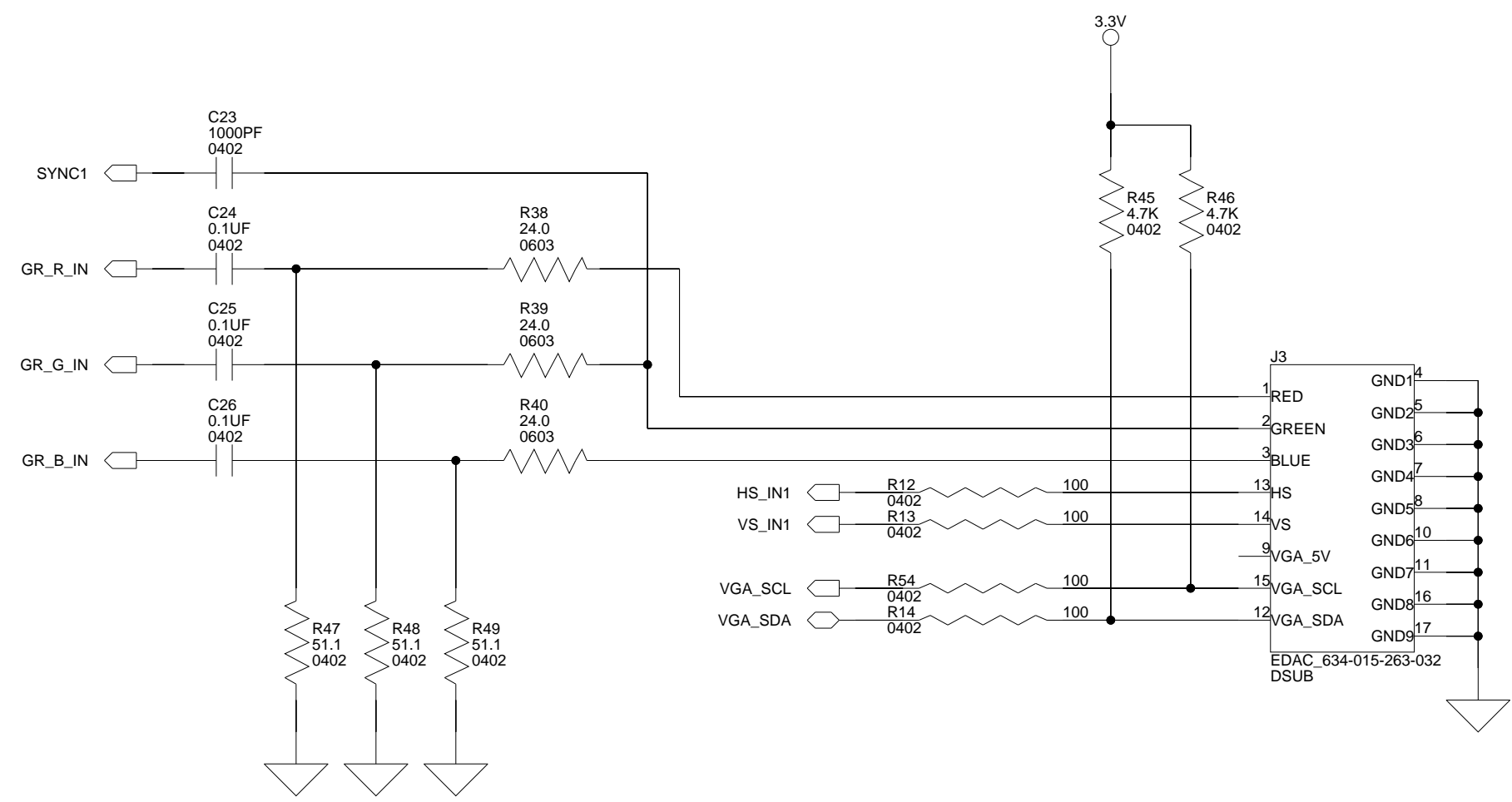

VGA

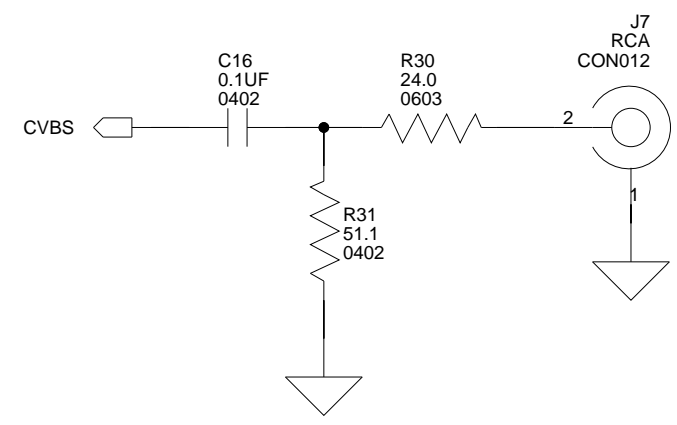

Composite

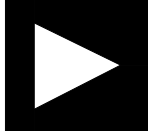
 ANALOG DEVICES		20 Cotton Road Nashua, NH 03063 PH: 1-800-ANALOGD	
		Title Video Decoder EI3 Extender Board Video Connectors 2	
Size C	Board No.	A0253-2010	
Date	3/7/12	Sheet	8 of 9
		Rev	1.0

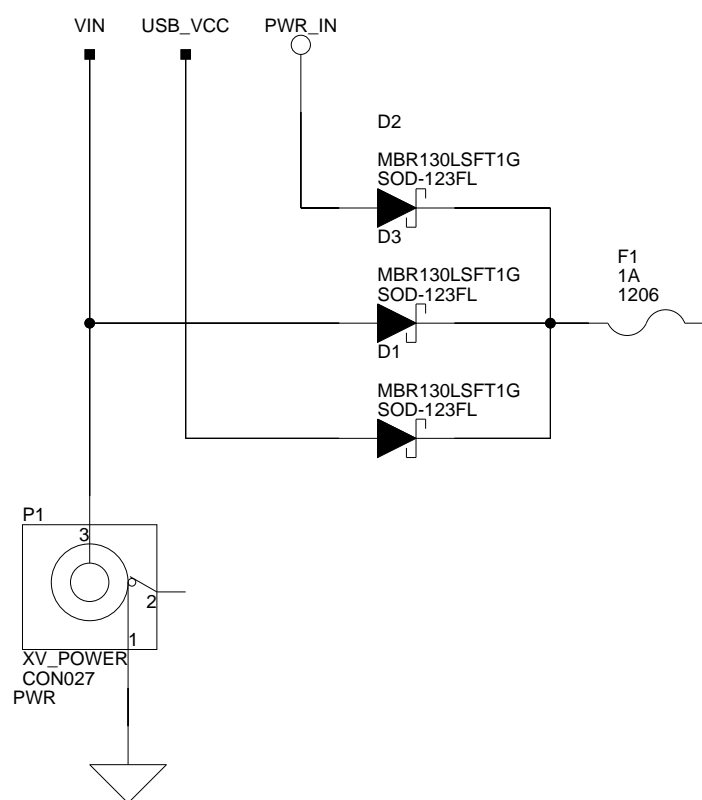
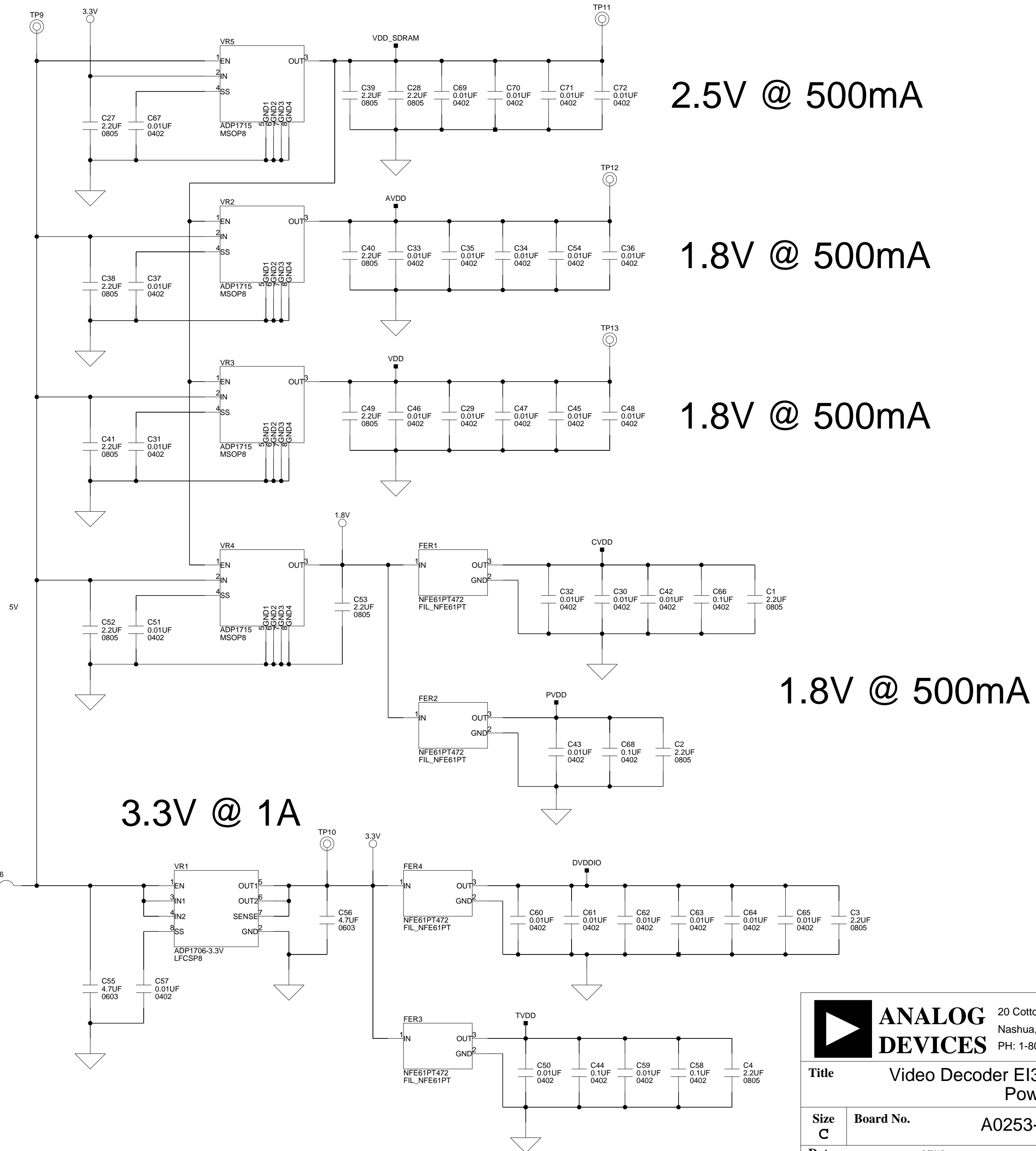
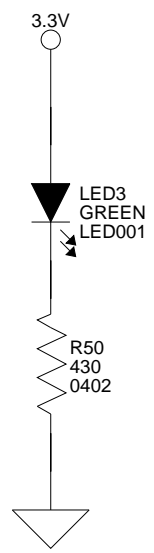

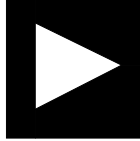
 ANALOG DEVICES		20 Cotton Road Nashua, NH 03063 PH: 1-800-ANALOGD	
		Title Video Decoder EI3 Extender Board Power	
Size C	Board No. A0253-2010	Rev 1.0	
Date 3/7/12	Sheet 9	of 9	

I INDEX

A

ADV7842

- high-performance receiver, [x](#), [1-3](#)
- ADV7842_INT_GPIOx signal, [2-9](#)
- component connector (J1), [2-11](#)
- composite connectors (J7), [2-13](#)
- HDMI connectors (J5-6), [2-12](#)
- SPORT_ENABLE signal, [2-9](#)
- S-video connector (J2), [2-11](#)
- VGA connector (J3), [2-11](#)

architecture, of Video Decoder EI3 Extender Board, [2-2](#)

B

- bill of materials, [A-1](#)
- board design database, [1-6](#)
- board schematic (Video Decoder EI3 Extender Board), [B-1](#)
- bus switch example, [2-5](#)

C

- component connector (J1), [2-11](#)
- composite connector (J7), [2-13](#)
- connectors
 - diagram of locations, [2-10](#)
 - J1 (component), [2-11](#)
 - J2 (S-video), [2-11](#)
 - J3 (VGA), [2-11](#)
 - J4 (EI3), [2-12](#)
 - J5-6 (HDMI), [2-12](#)

J7 (composite), [2-13](#)

P1 (power), [1-5](#), [2-13](#)

contents, of this Extender Board package, [1-2](#)

customer support, [xii](#)

D

- DIN connector, [2-11](#)
- DSUB15 connector, [2-11](#)

E

- example programs, [1-6](#)
- expansion interface III (EI3)
 - connector (J4), [2-12](#)
 - overview, [1-5](#)

F

- FET switches, [2-3](#), [2-4](#)

G

- GPIO
 - expander (U10), [2-8](#)
 - signal (ADV7842_INT_GPIOx), [2-8](#), [2-9](#)

H

- HDCP 1.4 support, [1-4](#)
- HDMI
 - connector (J5-6), [2-12](#)
 - detect LED (LED1-2), [2-14](#)

Index

receiver (ADV7842), [x](#), [1-3](#), [2-11](#), [2-12](#),
[2-13](#)
receptacles, [2-12](#)

I

installation, of this Extender Board, [1-2](#)

L

LEDs, [2-14](#)
LED1-2 (HDMI), [2-14](#)
LED3 (power), [2-14](#)

M

MCP23017 device, [2-7](#)
mechanical switch, [2-4](#), [2-6](#)

N

notation conventions, [xv](#)

P

package contents, [1-2](#)
power
connector (P1), [1-5](#), [2-13](#)
LED (LED3), [2-14](#)
product overview, [ix](#)

R

RCA jacks, [2-11](#), [2-13](#)

S

schematic, of Video Decoder EI3 Extender
Board, [B-1](#)
serial port (SPORT), [1-4](#)
SoftConfig (software-controlled switches)
examples, [2-3](#)
on the Extender Board, [2-8](#)
overview, [2-3](#)
programming, [2-7](#)
SPORT_ENABLE signal, [2-9](#)
supported products, [xiii](#)
S-video connector (J2), [2-11](#)
system architecture, [2-2](#)

T

TWI port, [1-4](#)
two-wire interface (TWI), [2-7](#)

V

VGA connector (J3), [2-11](#)
video
connectors, [x](#)
interface (ADV7842), [x](#)