

MALE END VIEW

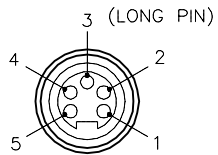

SPECIFICATIONS

CONTACT CARRIER MATERIAL	TPU
CONTACT MATERIAL/PLATING	BRASS/GOLD
HOUSING MATERIAL/PLATING	BRASS/NICKEL
O-RING MATERIAL	BUNA-N (NITRILE)
RATED CURRENT [A]	9.0 A
RATED VOLTAGE [V]	600 V
SOLDER CUP [MAX]	UP TO 16 AWG
TEMPERATURE RATING	-30°C to +80°C (-22°F to +176°F)
PROTECTION CLASS	MEETS NEMA 1,3,4,6P AND IEC IP67

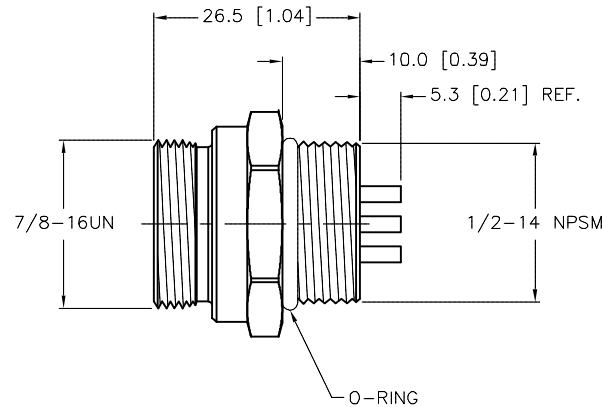
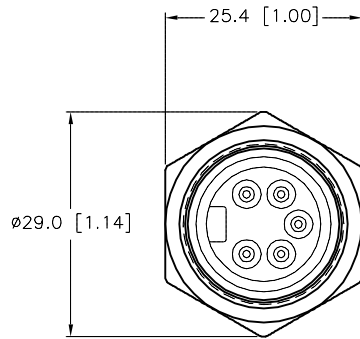

SOURCE DRAWING - FOR REFERENCE ONLY

RELATED DOCUMENTS 1. 2. 3. 4.	3RD ANGLE PROJECTION 	THIS DRAWING IS CONFIDENTIAL AND THE PROPERTY OF TURCK INC. USE OF THIS DOCUMENT WITHOUT WRITTEN PERMISSION IS PROHIBITED.		3000 CAMPUS DRIVE MINNEAPOLIS, MN 55441 1-800-544-7769 (763) 553-7300 (763) 553-0708 fax turck.com	
	MATERIAL  SEE SPECIFICATIONS	ALL DIMENSIONS DISPLAYED ON THIS DRAWING ARE FOR REFERENCE ONLY	DRFT JBJ DATE 02/27/04	DESCRIPTION RSFL 56	
FINISH  SEE SPECIFICATIONS	APVD SCALE 1=1.0				
		UNIT OF MEASUREMENT <b>MILLIMETER [ INCH ]</b>		IDENTIFICATION NO. U5229-12	
		CONTACT TURCK FOR MORE INFORMATION		REV B	
		DO NOT SCALE THIS DRAWING		FILE: U5229-12	

B	ADD O-RING PER ECO	KMY	12/06/12	40601
REV	DESCRIPTION	BY	DATE	ECO NO.