

Schnitt A-A / cross section A-A

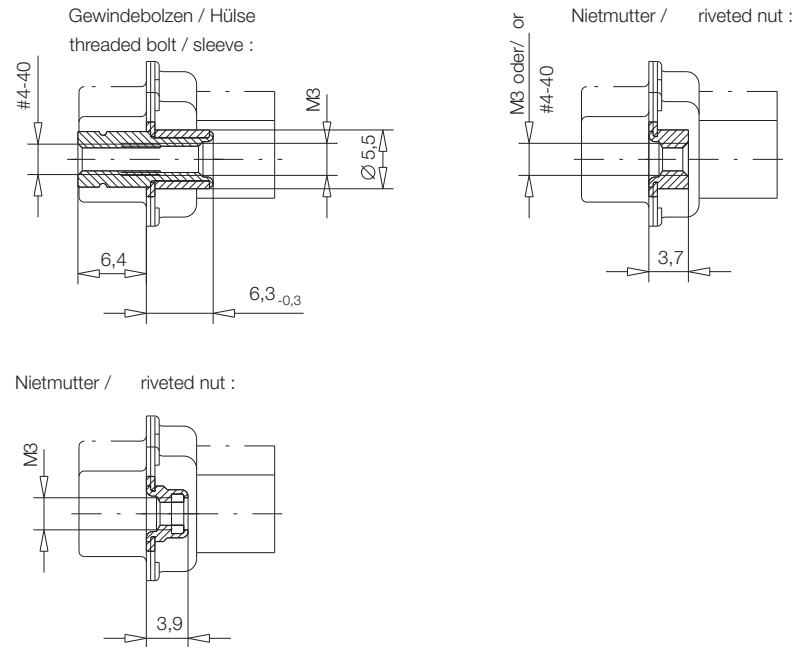
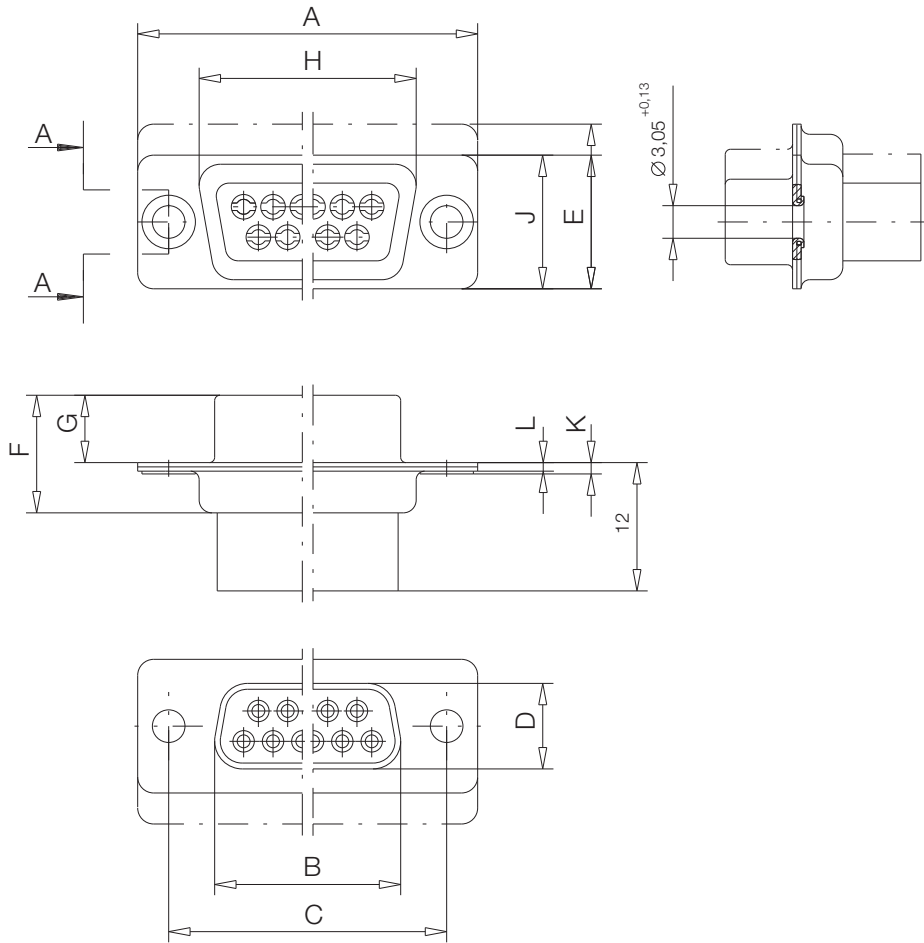

9	30.8	16.4	25.0	8.0	12.5	11.0	6.3	19.3	10.8	1.5	0.8		
15	39.1	24.7	33.3	8.0	12.5	11.0	6.3	27.5	10.8	1.5	0.8		
25	53.0	38.5	47.0	8.0	12.5	11.0	6.3	41.3	10.8	1.5	0.8		
37	69.3	54.9	63.5	8.0	12.5	11.0	6.3	57.7	10.8	1.5	0.8		
50	67.0	52.5	61.1	10.8	15.4	11.0	6.3	55.3	13.6	1.5	0.8		
Polzahl/ No. of contacts	A $\pm 0,3$	B $-0,2$	C $\pm 0,2$	D $-0,2$	E $\pm 0,3$	F $\pm 0,2$	G $-0,3$	H $\pm 0,3$	J $\pm 0,2$	K max.	L $\pm 0,1$		

Ident-Nr. / Part No. : Refer to table on page 2

Polzahl / No. of contacts : Refer to table on page 2

Anschlußart / Terminal Type : CRIMP-SNAP IN

Anschlußlänge / Terminal Length : Refer to table on page 2

Bauart / Type : 1

Anforderungsstufe / Class : Refer to table on page 2

Aufdruck / Logo : ERNI 1

Zubehör / Accessory : Refer to table on page 2

Sonderausführung / Special : Refer to table on page 2

Fehlende Masse und Angaben siehe DIN 41652 / Missing information and dimensions according to DIN 41652

Sonstige Angaben siehe Fertigungsunterlagen / Additional indications please see the production documentation

Information:	Tolerances All Dimensions in mm	Scale 2:1
All rights reserved. Only for information. To insure that this is the latest version of this drawing, please contact one of the ERNI companies before using.	Subject to modification without prior notice. Drawing will not be updated.	Designation TMC-S 9 bis 50-CSI TMC-S 9 to 50-CSI
www.ERNI.com		054872
c Index	27.04.1999 Date	M:00021176.SZN TMCS

Ordering Information

D-Sub Connector Crimp Snap-in Vertical Female

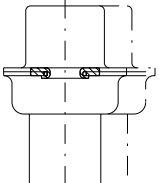
Number of Pins	9	15	25	37	50
	Through hole				
	014176	014178	014180	014182	014184

Ordering Information for Crimp Contacts

Version	Loose contacts	Reel 500 pieces	Reel 10.000 pieces
AWG 26-20	014234	014237	014240
AWG 28-24	014233	014236	014239

Ordering Information for Processing Tools

Version

Hand crimping tool for loose contacts AWG 20-28 (0.08-0.56 mm ²)	014374
Hand crimping tool for reels with 500 contacts incl. reel holder AWG 20-28	014375
Mounting and dismounting tool for AWG 20-28	014373