

USER MANUAL

MODEL 2120 RS-232 Single Port Terminal Server



PE PATTON
Electronics Co.

07M2120-A
Revised 3/26/01

SALES OFFICE
(301) 975-1000
TECHNICAL SUPPORT
(301) 975-1007

TABLE OF CONTENTS

1.0	Warranty Information	3
1.1	Radio And TV Interference	3
1.2	CE Notice.....	3
1.3	Service.....	4
2.0	General Information.....	5
2.1	Product Features	5
2.2	Software Features	5
	RS-232 Serial Interface	5
	Raw TCP/TELNET	6
	System Features	6
	Pending Software Features	8
2.3	Description.....	8
3.0	Configuration	10
3.1	Configuration Switches	10
	Default Settings	11
	Detailed Switch Settings.....	11
3.2	Software Configuration	11
	Model 2120 Software Command System	11
	Model 2120 Help Menu/Command Hierarchy	12
	Entering Commands.....	14
	Activating Configuration Commands	14
3.3	Default Configuration Parameters	14
	EIA232 Interface Defaults.....	14
	RawTCP/Telnet Defaults	15
	System Defaults	15
3.4	Initial Unit Configuration.....	16
3.5	Remote Configuration of the Unit	18
3.6	Software Installation Instructions	19
	Software Installation Procedures Using Your Own FTP Server.....	19
	Software Installation Procedures Using Patton's FTP Server	20
4.0	Installation.....	22
4.1	Model 2120 Connection	22
4.2	AC Power Connection	22
5.0	Operation.....	23
5.1	LED Status Indicators	23
	Rear Panel LEDs.....	23
	Top Panel LEDs	24
A	Model 2120 Single Port Terminal Server Specifications.....	25
B	Model 2120 Single Port Terminal Server Software Command Definitions	26

C Model 2120 Single Port Terminal Server
Application Notes 39

1.0 WARRANTY INFORMATION

Patton Electronics warrants all Model 2120 components to be free from defects, and will—at our option—repair or replace the product should it fail within one year from the first date of shipment.

This warranty is limited to defects in workmanship or materials, and does not cover customer damage, abuse or unauthorized modification. If this product fails or does not perform as warranted, your sole recourse shall be repair or replacement as described above. Under no condition shall **Patton Electronics** be liable for any damages incurred by the use of this product. These damages include, but are not limited to, the following: lost profits, lost savings and incidental or consequential damages arising from the use of or inability to use this product. **Patton Electronics** specifically disclaims all other warranties, expressed or implied, and the installation or use of this product shall be deemed an acceptance of these terms by the user.

1.1 RADIO AND TV INTERFERENCE

The Model 2120 generates and uses radio frequency energy, and if not installed and used properly—that is, in strict accordance with the manufacturer's instructions—may cause interference to radio and television reception. The Model 2120 has been tested and found to comply with the limits for a Class A computing device in accordance with the specifications in Subpart J of Part 15 of FCC rules, which are designed to provide reasonable protection from such interference in a commercial installation. However, there is no guarantee that interference will not occur in a particular installation. If the Model 2120 does cause interference to radio or television reception, which can be determined by disconnecting the RS-232 interface, the user is encouraged to try to correct the interference by one or more of the following measures: moving the computing equipment away from the receiver, re-orienting the receiving antenna and/or plugging the receiving equipment into a different AC outlet (such that the computing equipment and receiver are on different branches).

1.2 CE NOTICE

The CE symbol on your Patton Electronics equipment indicates that it is in compliance with the Electromagnetic Compatibility (EMC) directive and the Low Voltage Directive (LVD) of the European Union (EU). A Certificate of Compliance is available by contacting Technical Support.

1.3 SERVICE

All warranty and non-warranty repairs must be returned freight prepaid and insured to Patton Electronics. All returns must have a Return Materials Authorization number on the outside of the shipping container. This number may be obtained from Patton Electronics Technical Service at **(301) 975-1007**. *Packages received without an RMA number will not be accepted.*

Patton Electronics' technical staff is also available to answer any questions that might arise concerning the installation or use of your Model 2120. Technical Service hours: **8AM to 5PM EST, Monday through Friday**.

Note THIS DEVICE IS NOT INTENDED TO BE CONNECTED TO THE PUBLIC NETWORK.

2.0 GENERAL INFORMATION

Thank you for your purchase of this Patton Electronics product. This product has been thoroughly tested and is warranted for One Year parts and labor. If any questions or problems arise during installation or use of this product, please do not hesitate to contact Patton Electronics Technical Support at (301) 975-1007.

2.1 PRODUCT FEATURES

- Enables control of any RS-232 asynchronous serial device over a LAN or via the Internet
- Asynchronous data rates up to 115.2 kbps
- DTE/DCE-selectable serial port
- RS-232 status indicators
- 802.3 10Base-T LAN connection via RJ-45 for network connection
- Ethernet link and status indicators
- User-configurable session options
- Supports standard TCP/IP protocols (TCP, UDP, IP, ICMP, TELNET, RLOGIN, ARP, DHCP, FTP, TFTP, SLIP, and PPP)
- Comes with 1 Mbyte RAM and 512 kbytes FLASH
- Small package attaches directly to terminal equipment
- AC or DC power options
- Software updates via Patton's FTP site
- Can be used as single-port remote access server

2.2 SOFTWARE FEATURES

RS-232 Serial Interface

- Selectable asynchronous data rates from 4,800 kbps to 115.2 kbps
- Selectable serial port options of DCE, DTE
- DCE/DTE on configuration reset (SW2)
- Selectable RS-232 character length options of 5, 6, 7, 8

- Selectable RS-232 flow control options of none, hardware, xonxoff
- Selectable RS-232 parity options of none, odd, even, high
- Selectable RS-232 stop length options of 1, 2
- Selectable RS-232 interface protocol options of telnet, rawtcp (slip/ppp future)

Raw TCP/TELNET

- Permits automatic connection request to a remote device
- Permits incoming connection requests from remote devices on the serial interface
- Selectable frequency (in seconds) of the automatic connection requests to remote device
- Selectable serial interface inactivity timeout (minutes) with disable option
- Selectable TCP port number for serial interface
- Optional User ID & Password protection for access to serial interface
- Selectable destination IP address for sending automatic connection requests to a remote device
- Selectable TCP port number for sending automatic connection requests to a remote device
- Optional User ID & Password capability when sending automatic connection requests to remote device
- Selectable serial interface session termination character

System Features

- Ability to display boot message on the serial interface
- Selectable default gateway IP address for use when the destination IP address cannot be found
- DHCP enable/disable
- Selectable unit IP address
- Ability to change factory assigned unit MAC Address

- Ability to enable/disable unit management/configuration via remote Telnet session
- Selectable unit management inactivity timeout (minutes) with disable option
- Optional Management ID & Password protection for users attempting a Telnet session
- Ability to change the preset system command prompt (TS>)
- Selectable unit Subnet Mask
- Ability to remotely perform a soft boot of the unit
- Configuration reset to factory default configuration via SW1 (Will not reset MAC Address)
- Ability to clear configuration changes prior to being activated/written to memory
- Ability to reset non-volatile configuration parameters
- Ability to remotely close the serial interface connection
- Ability to FTP to a remote device
- Ability to Ping to a remote device
- Ability to Raw-TCP to a remote device
- Ability to Telnet to a remote device
- Ability to download software using UTP and write/activate to flash memory
- Ability to view all current serial interface related parameters
- Ability to view current setting of each individual serial interface related parameter
- Ability to view all current Raw-TCP related parameters
- Ability to view current setting of each individual Raw-TCP related parameters
- Ability to view all current system related parameters
- Ability to view current setting of each individual system related parameters

- Ability to view TCP connection state
- Ability to view DHCP state, passed lease time (seconds), renew lease time (seconds), rebind lease time (seconds), and expire lease time (seconds)
- Ability to view current software version

Pending Software Features

- Single port Remote Access Device Capabilities & Parameters (SLIP & PPP with PAP & CHAP)
- TFTP functionality
- Data rates of 50 bps to 2,400 bps
- Data rates of 230,400 bps & 460,800 bps

2.3 DESCRIPTION

The Patton Model 2120 (see Figure 1) is a single port terminal server that enables RS-232 asynchronous devices to connect with other devices over the 10Base-T Ethernet LAN. Serial asynchronous device connectivity across the LAN is provided using Telnet/TCP or Raw-TCP protocols.

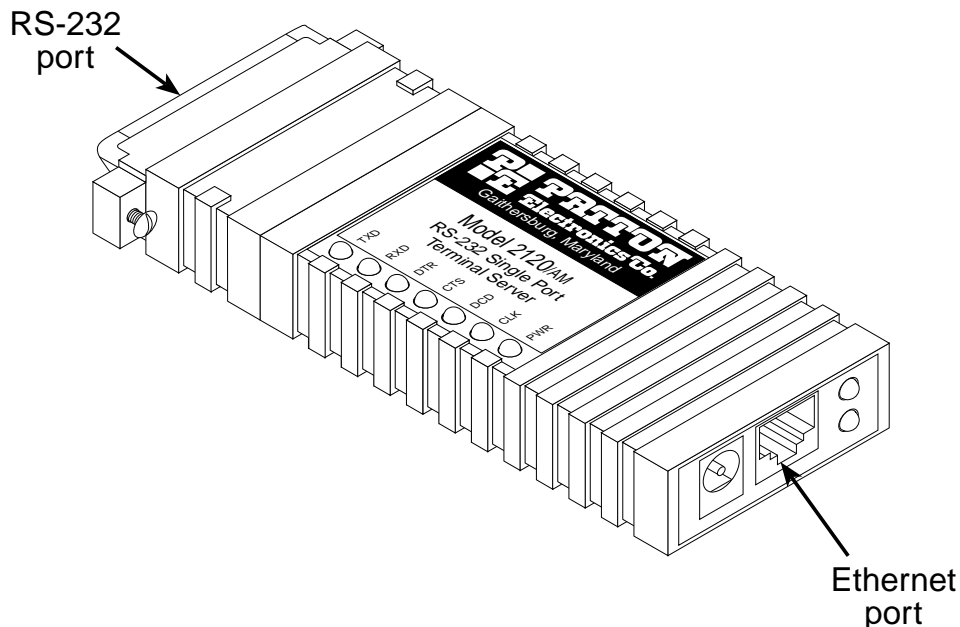

Figure 1. Model 2120 showing location of Ethernet and RS-232 ports.

The Model 2120 is initially configured via the serial interface using a dumb terminal or terminal emulation software in VT-100 mode. The serial interface factory default asynchronous setting is 9600 bits/second, 8 bits

per character, no parity, and 1 stop bit. All configuration parameters can be set via the serial interface for many types of applications. Once initial configuration is complete with an assigned IP address, the 2120 configuration parameters can be modified over the LAN using a Telnet session. Optional user ID and password can be configured to provide security into this convenient feature.

The Model 2120 uses an integrated FTP (File Transfer Protocol) client to obtain new program images and communicate with an FTP server. The FTP client logs onto the FTP server and then can browse and display files located on the FTP server. The FTP client can also obtain a new program image (software release) from the FTP server. The program image is first obtained from the FTP server across the LAN and then stored in FLASH memory. This enables the Model 2120 to obtain new functionality both easily and quickly. The latest Model 2120 software release is available for download via upgrades.patton.com.

The Model 2120 can use DHCP (Dynamic Host Configuration Protocol) to dynamically obtain the unit IP address over the LAN from a DHCP server. The 2120 sends the DHCP server MAC address information and dynamically obtains its IP address based on the unit MAC address. This feature reduces the numbers of IP addresses on the network and minimizes network administration.

Future SLIP and PPP functionality will enable the 2120 to serve as a single port remote access server.

3.0 CONFIGURATION

3.1 CONFIGURATION SWITCHES

SW1 is a set of four internal DIP switches (see Figure 2) that are used for configuration reset purposes only. To access switch set SW1, use a small flat blade screwdriver to open the Model 2120's case as shown in Figure 3.

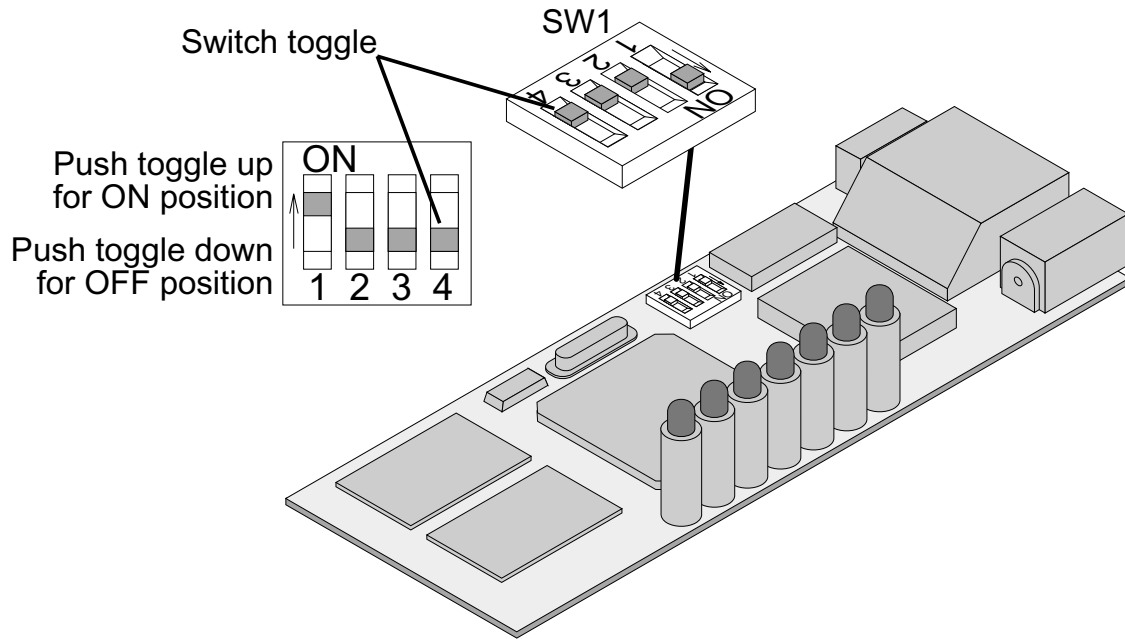

Figure 2. Switch set SW1 location

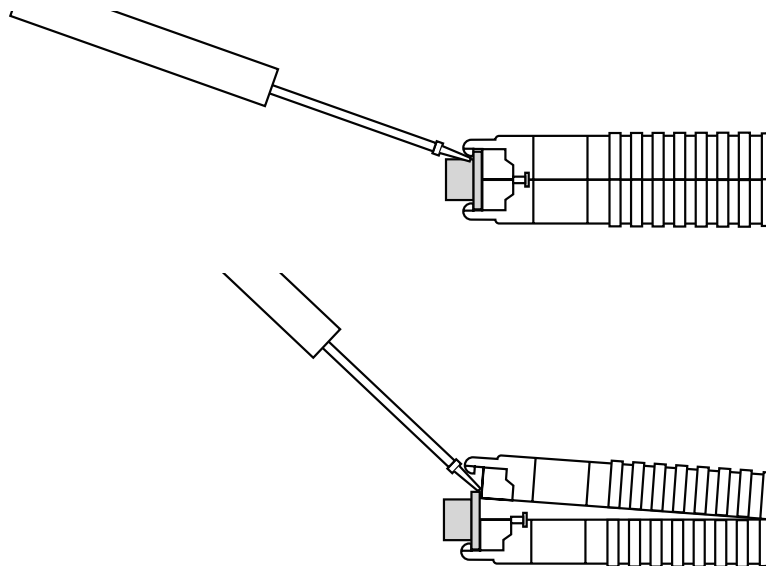

Figure 3. Opening the Model 2120 case

To configure the DIP switches, use a small screwdriver and gently push each switch to its proper setting. The ON and OFF positions are shown in Figure 2.

Default Settings

Default settings for the DIP switches are as follows:

Position	Function	Factory Default
SW1	Configuration Reset	OFF
SW2	DCE/DTE on Config Reset	OFF
SW3	Not Used (Must Be OFF)	OFF
SW4	Not Used (Must Be OFF)	OFF

Detailed Switch Settings

This section provides detailed information about the function of each DIP switch and lists all possible settings.

- Switch 1: Configuration Reset. Set this switch to the ON position and power cycle the unit to reset to the factory default configuration parameters.

Note This will not change the factory assigned NIC/MAC address.

- Switch 2: DCE/DTE on Configuration Reset. When a configuration reset is being performed via Switch 1 (above), set this switch to the ON position to force the serial interface to DTE or to the OFF position to force the serial interface to DCE.

Note This switch is ONLY read when the configuration is reset through Switch 1 (above).

- Switch 3: Not Used. This switch is not used and must remain in the OFF position.
- Switch 4: Not Used. This switch is not used and must remain in the OFF position.

3.2 SOFTWARE CONFIGURATION

The Model 2120 software features a menu-driven command system that enables the configuration of the unit via the serial interface using a VT-100 terminal or emulation session or over the LAN using a Telnet session. Since the Model 2120 is not pre-configured with an IP address for your network, initial configuration of the Model 2120 is performed via the serial interface (See “Initial Unit Configuration” on page 17).

Model 2120 Software Command System

The Model 2120 Software Command System is designed with a series of help menus and commands derived from the actual function descriptions. Once a session has been established with the 2120 and the sys-

tem prompt (**TS>**) appears, the main help menu (see Figure 4) will be displayed by pressing the <**Enter**> key.

```
*** Help Menu ***

activateimage - Activate Image Acquired With FTP Get
boot          - Boot System
configure     - Configure Parameters
eiaconclose  - EIA232 Connection Close
ftp           - FTP To Remote Device
ping         - Ping Remote Device
rawtcp       - Raw-TCP To Remote Device
show         - Show Parameters and Statistics
telnet       - Telnet To Remote Device
```

Figure 4. Main Help Menu

Model 2120 Help Menu/Command Hierarchy

The help menu/command hierarchy is shown in Figure 5 on page 14.

Note For a detailed definition of all Model 2120 system commands, valid entries, and defaults see Appendix B on page 27.

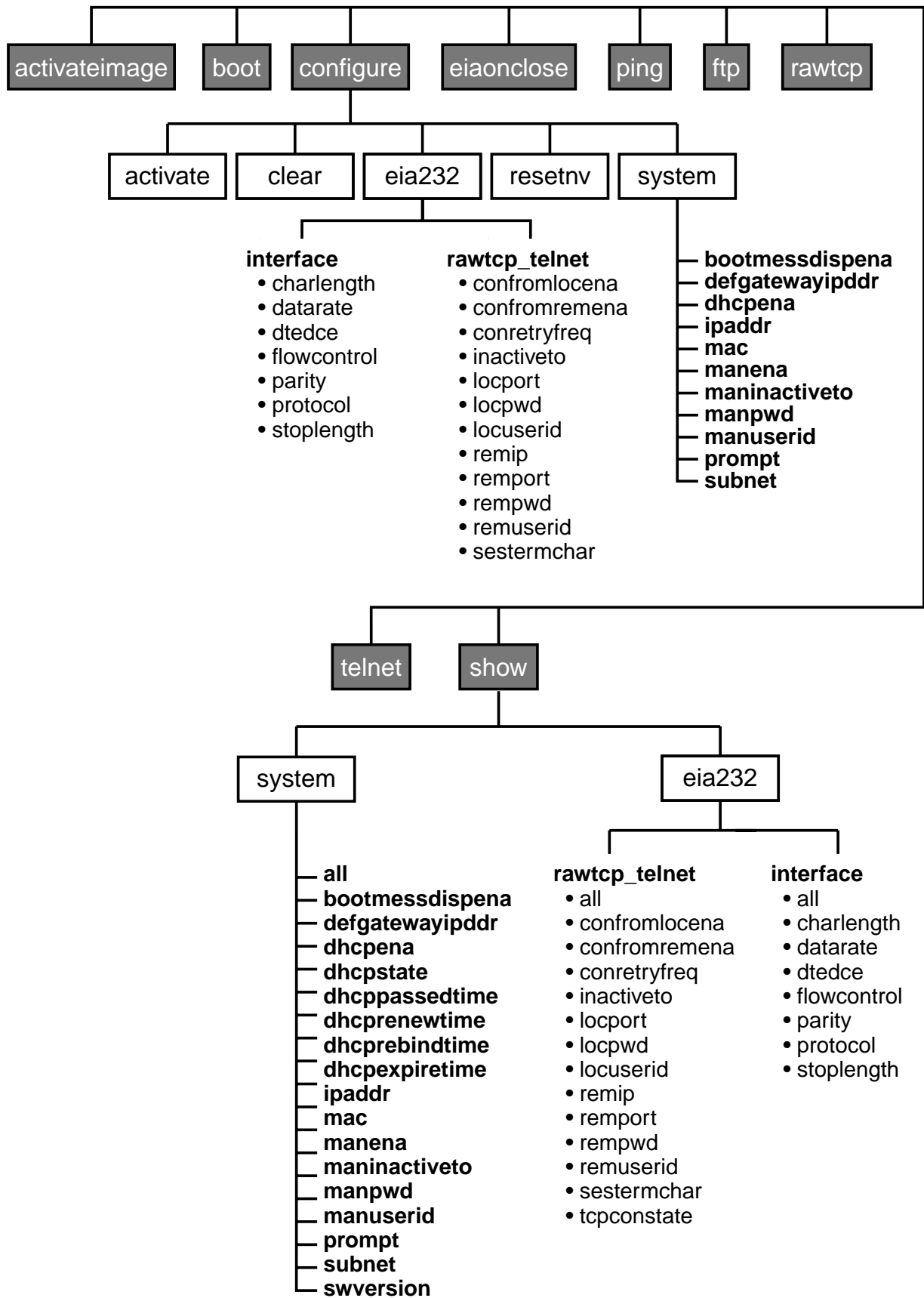

Figure 5. Model 2120 Help Menu/Command Hierarchy

Entering Commands

Commands are executed by typing the appropriate command or commands at the system prompt (TS>) followed by a valid entry (if applicable) and the <Enter> key. If entering multiple commands, they must be entered in hierarchy order (See “Model 2120 Help Menu/Command Hierarchy” on page 13) and separated by a space. For example, the following command string is entered to set the serial interface data rate to 115.2 kbps:

```
TS>configure eia232 interface datarate 115200<Enter>
```

For a single entry command such as “boot”, the following command is entered to remotely boot the Model 2120:

```
TS>boot<Enter>
```

Activating Configuration Commands

The Model 2120 configuration parameters can be changed by using the “configure” command and associated sub-commands. Immediately after the necessary “configure” command string is entered, the “configure activate” command **must be entered in order to activate the changes and write them to flash memory**. For example, the command string used to set the serial interface data rate to 115.2 kbps (see section “Entering Commands”) must be immediately followed by the following command:

```
TS>configure eia232 interface datarate 115200<Enter>
```

```
TS>configure activate<Enter>
```

If successfully activated, the message “Activate is complete!” will display.

Note The “configure activate” command MUST be entered after each configuration change!

3.3 DEFAULT CONFIGURATION PARAMETERS

The Model 2120 software is pre-configured with the following factory default settings.

EIA232 Interface Defaults

- RS-232 Character Length: **8** (bits)
- RS-232 Datarate: **9600** (bits per second)
- RS-232 DTE/DCE Physical Port: **DCE**
- RS-232 Flow Control: **none**

- RS-232 Parity: **none**
- RS-232 Protocol: **Telnet**
- RS-232 Stop Length: **1** (bits)

RawTCP/Telnet Defaults

- Connection From Local Enable: **no**
- Connection From Remote Enable: **yes**
- Connection Retry Frequency: **0** (seconds)
- Inactive Timeout: **15** (minutes)
- Local Port: **404**
- Local Password: **UNDEFINED** (no entry)
- Local User ID: **UNDEFINED** (no entry)
- Remote IP Address: **1.1.1.8**
- Remote Port: **23**
- Remote Password: **UNDEFINED** (no entry)
- Remote User ID: **UNDEFINED** (no entry)
- Session Termination Character: **4** (Control-D)

System Defaults

- Boot Message Display Enable: **yes**
- Default Gateway IP Address: **0.0.0.0** (disabled)
- DHCP Enable: **yes**
- IP Address: **2.2.2.2**
- MAC Address: **0x000102030405**
- Management Enable: **yes**
- Management Inactive Timeout: **15** (minutes)
- Management Password: **UNDEFINED** (no entry)
- Management User ID: **UNDEFINED** (no entry)

- Prompt: **TS>**
- Subnet Mask: **255.255.255.0**

3.4 INITIAL UNIT CONFIGURATION

Unless pre-configured with an IP address for your LAN (not standard), the Model 2120 must be initially configured via the serial interface using the menu-driven command system and required terminal equipment as described below:

1. Verify that the four internal DIP switches are set to the OFF position (factory default).
2. Using ribbon cable or other similar cable, connect the serial RS-232 port of a VT-100 ASCII terminal or similar DTE with terminal emulation software to the RS-232 port of the Model 2120.
3. Power up the emulation device and configure its RS-232 port as follows:
 - 9600 Baud
 - 8 data bits, 1 stop bit, no parity
 - ANSI, VT100 emulation
4. Power up the Model 2120.
5. After the Model 2120 is powered on, the ASCII terminal or emulation device should display the following message:

```
Model 2120 Terminal Server
Software Version 3.0.8
TS>
```

Note If you are unable to connect with the Model 2120 and you have rechecked your terminal emulation settings, it is recommended that a configuration reset (to factory defaults) be performed on the Model 2120 by setting internal dip switch #1 to the ON position and power cycling the Model 2120. Once powered on, set switch #1 back to the OFF position. If still unable to establish a connection, please contact Patton Electronics Technical Support at (301) 975-1007.

6. Press the **<Enter>** key to see the main help menu screen.

```
*** Help Menu ***
```

```
activateimage - Activate Image Acquired With FTP Get
```

```
boot          - Boot System
configure     - Configure Parameters
eiaconclose   - EIA232 Connection Close
ftp           - FTP To Remote Device
ping          - Ping Remote Device
rawtcp        - Raw-TCP To Remote Device
show          - Show Parameters and Statistics
telnet        - Telnet To Remote Device
```

TS>

7. Before proceeding with the configuration of the Model 2120 for your application, it is suggested that the following “show all” commands be executed in order to view the current system and *eia232* configuration parameters:

```
TS>show system all<Enter>
```

```
Boot Message Display Enable: yes
Default Gateway IP Address: 0.0.0.0
DHCP Enable: yes
DHCP State: initialize
DHCP Passed Lease Time (seconds): 0
DHCP Renew Lease Time (seconds): 0
DHCP Rebind Lease Time (seconds): 0
DHCP Expire Lease Time (seconds): 0
IP Address: 2.2.2.2
MAC Address: (Factory Assigned MAC/NIC Address)
Management Enable: yes
Management Inactive Timeout: 15
Management Password: (UNDEFINED)
Management User ID: (UNDEFINED)
Prompt: TS>
Subnet Mask: 255.255.255.0
Software Version: 3.0.8
```

```
TS>show eia232 interface all<Enter>
```

```
Character Length: 8
Datarate: 9600
DTE / DCE Physical Port: dce
Flow Control: none
Parity: none
Protocol: telnet
Stop Length: 1
```

```
TS>show eia232 rawtcp_telnet all<Enter>
```

```
Connection From Local Enable: no
Connection From Remote Enable: yes
Connection Retry Frequency: 0
```

Inactive Timeout: 15
Local Port: 404
Local Password: (UNDEFINED)
Local User ID: (UNDEFINED)
Remote IP Address: 1.1.1.8
Remote Port: 23
Remote Password: (UNDEFINED)
Remote User ID: (UNDEFINED)
Session Termination Character: 0x04
TCP Connection State: listen

8. You are now ready to configure the Model 2120 for your application. Configuration parameters will vary based upon the requirements of each application.

For a detailed definition of all 2120 system commands, valid entries, and defaults see Appendix B on page 27. In addition, the Application Notes provided in Appendix C on page 40 can be used as a helpful reference when configuring the Model 2120 for various applications.

Note Contact your Network Administrator if you have questions regarding configuration parameters required for your application and/or LAN.

3.5 REMOTE CONFIGURATION OF THE UNIT

Once you have performed the initial configuration and the Model 2120 is connected to and communicating with a LAN, the configuration parameters can be changed remotely from anywhere on the LAN using an FTP Client (i.e. Windows Command Mode) on a computer that can communicate over the LAN.

1. From the Windows "Run" prompt at your computer, type: **command** and click **OK**.
2. At the DOS prompt, Telnet into the 2120 by typing:
telnet <the IP address of the 2120>
and pressing **<Enter>**.
3. When connected to the 2120, the computer should display the following message:

```
Model 2120 Terminal Server - Telnet Session  
Software Version: 3.0.8  
TS>
```

4. Press the "Enter" key to see the main help menu screen.

```
*** Help Menu ***
```

```
activateimage - Activate Image Acquired With FTP Get
```

boot	- Boot System
configure	- Configure Parameters
eiaconclose	- EIA232 Connection Close
ftp	- FTP To Remote Device
ping	- Ping Remote Device
rawtcp	- Raw-TCP To Remote Device
show	- Show Parameters and Statistics
telnet	- Telnet To Remote Device

TS>

5. You are now ready to change the configuration of the Model 2120 for your application.

For a detailed definition of all 2120 system commands, valid entries, and defaults see Appendix B on page 27. In addition, the Application Notes provided in Appendix C on page 40 can be used as a helpful reference for when configuring the Model 2120 for various Model 2120 applications.

Note Contact your Network Administrator if you have questions regarding configuration parameters required for your application and/or LAN.

3.6 SOFTWARE INSTALLATION INSTRUCTIONS

Because the Model 2120 stores its software in FLASH Memory, obtaining the latest software release is both quick and easy. Using the integrated FTP (File Transfer Protocol) client, new software releases can be obtained over the LAN from your own FTP server or Patton's FTP Server via upgrades.patton.com.

Software Installation Procedures Using Your Own FTP Server

Requirements

The following conditions must be met before loading new operational software on your Model 2120:

- You must have a valid IP address assigned to the Model 2120 and the Model 2120 must be connected to the LAN
- You must have an FTP Client (i.e. Windows Command Mode) on a computer that can communicate over the LAN
- You must load the most current version Model 2120 software in a valid directory on your FTP Server

Procedures

To load new software into the 2120, execute the following steps:

1. From the Windows "Run" prompt at your computer, type: **command** and click **OK**.
2. At the DOS prompt, Telnet into the 2120 by typing **telnet <the IP address of the 2120>** and pressing **<Enter>**.
3. At the Terminal Server prompt (TS>), FTP into the FTP Server where the 2120 software resides by typing **ftp <the IP address of the FTP Server>** and pressing **<Enter>**.
4. If prompted for Username, type: **<assigned Username>** and press **<Enter>**.
5. If prompted for Password, type: **<assigned Password>** and press **<Enter>**.
6. At the FTP prompt, type: **get <current 2120 software file-name>** and press **<Enter>**.
7. If completed, type: **quit** and press **<Enter>** to return to the TS prompt
8. At the TS prompt, type: **<activateimage>** and press **<Enter>**.
9. Once the image is activated, you will lose your connection to the Model 2120.

To verify new software version, TELNET back into the 2120 by typing **telnet <the IP address of the 2120>** and press **<Enter>**. The new software version should be listed at the top of the screen.

Software Installation Procedures Using Patton's FTP Server

Requirements

The following conditions must be met before loading new operational software on your 2120:

- You must have a valid IP address assigned to the Model 2120 and the 2120 must be connected to the LAN with Internet access
- You must have an FTP Client (i.e. Windows Command Mode) on a computer that can communicate over the LAN

- You must obtain a Patton Username and Password and obtain the IP address of Patton's FTP Server and current 2120 software version file-name from *upgrades.patton.com*.

Procedures

To load new software into the 2120, execute the following steps:

1. From the Windows "Run" prompt at your computer, type: **command** and click **OK**.
2. At the DOS prompt, Telnet into the 2120 by typing: **telnet <the IP address of the 2120>** and pressing **<Enter>**.
3. At the Terminal Server prompt (TS>), FTP into Patton's FTP Server by typing: **ftp <the IP address of Patton's FTP Server>** and pressing **<Enter>**.
4. Enter FTP Username by typing: **<ftp>** and pressing **<Enter>**.
5. Enter your FTP Password by typing: **<your e-mail address>** and pressing **<Enter>**.
6. At the FTP prompt, type: **get <current 2120 software file-name>** and press **<Enter>**.
7. When completed, type: **quit** and press **<Enter>** to return to the TS prompt.
8. At the TS prompt, type: **<activateimage>** and press **<Enter>**.
9. Once the image is activated, you will lose your connection to the Model 2120.

To verify new software version, TELNET back into the 2120 by typing **telnet <the IP address of the 2120>** and pressing **<Enter>**. The new software version should be listed at the top of the screen.

4.0 INSTALLATION

Once the Model 2120 is configured, it is ready to connect to the serial interface of the RS-232 device, to the Ethernet interface, and to the power source. The Model 2120 is designed to connect an asynchronous RS-232 device to other devices via the LAN/10Base-T interface. This section describes how to install the 2120.

4.1 MODEL 2120 CONNECTION

The Model 2120 features a DB-25 (Male or Female) serial interface and an RJ-45 Female Ethernet interface. The 2120 conveniently attaches and secures to the serial port of the RS-232 device with the DB-25 connector and connector screws. The 2120 connects to any standard LAN connection (usually an RJ-45F Jack) using a standard LAN patch cord (not provided with 2120).

In the drawing below, the Model 2120 is attached directly to a card reader and will use its individually assigned IP address so that the host PC can communicate with the card reader over the Ethernet LAN. Using a communications protocol such as Telnet or Raw-TCP, the host PC will poll and monitor the card reader for various types of data.

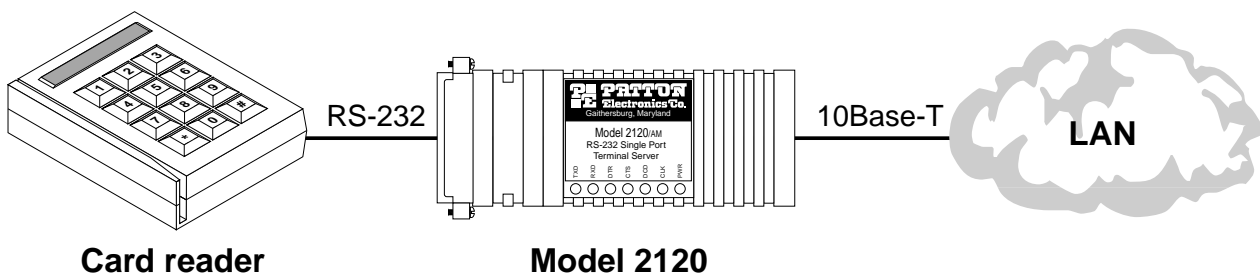

Figure 6. A Typical RS-232 to 10BaseT Ethernet Installation

4.2 AC POWER CONNECTION

The Model 2120 uses a 5VDC, 2A universal input, power supply that is equipped with a male IEC-320 power entry connector and supports a voltage range of 100–240VAC. This transformer connects to the Model 2120 by means of a cannon jack on the rear panel. There are a variety of domestic and international power cords available for the power entry. The Model 2120 is powered-up as soon as it is plugged into an AC outlet (there is no power switch). The 2120 features an LED indicator for Power and when lit, the 2120 is receiving power from the AC outlet.

5.0 OPERATION

After configuring and installing the Model 2120, you are ready for operation. This section describes the operation of the Model 2120 Single Port Terminal Server.

5.1 LED STATUS INDICATORS

The Model 2120 features seven top panel LEDs and two rear panel LEDs. The figures below show the their position. A description of each LED follows each figure.

Rear Panel LEDs

Figure 7 shows the LEDs on the rear panel, Table 1. lists the LED definitions.

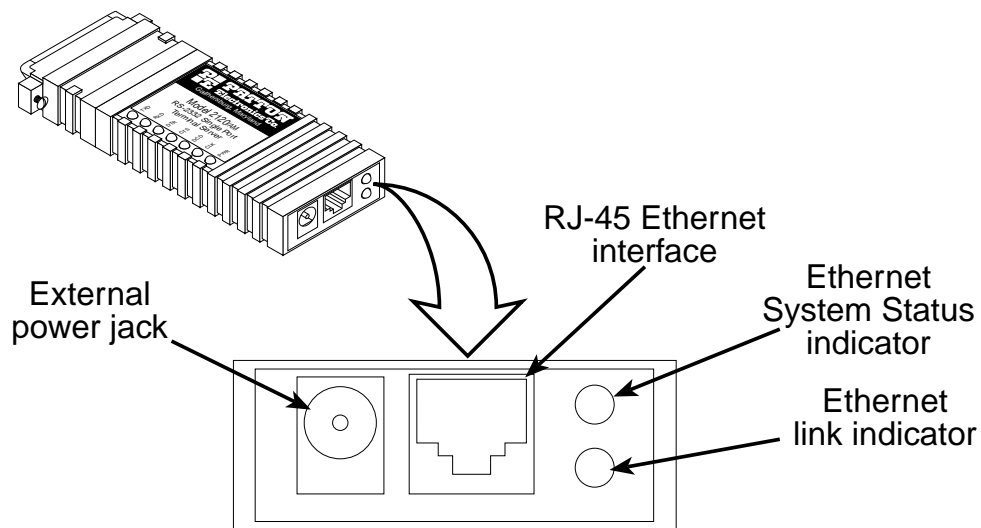

Figure 7. Model 2120 Rear Panel LEDs

Table 1: Model 2120 Rear Panel LED definitions

LED	Description
Link	Glows green to indicate that the Ethernet signal from the LAN is active.
Status	Blinks yellow indicating the system status as follows:
2 Blinks:	TCP Connection Established
3 Blinks:	TCP Connection Not Established
4 Blinks:	DB25 Data Rate Is 50 BPS
5 Blinks:	DB25 Data Rate Is 75 BPS
6 Blinks:	DB25 Data Rate Is 150 BPS
7 Blinks:	DB25 Data Rate Is 300 BPS
8 Blinks:	DB25 Data Rate Is 600 BPS
9 Blinks:	DB25 Data Rate Is 1200 BPS
10 Blinks:	DB25 Data Rate Is 2400 BPS

Table 1: Model 2120 Rear Panel LED definitions

LED	Description
11 Blinks:	DB25 Data Rate Is 4800 BPS
12 Blinks:	DB25 Data Rate Is 9600 BPS
13 Blinks:	DB25 Data Rate Is 19200 BPS
14 Blinks:	DB25 Data Rate Is 38400 BPS
15 Blinks:	DB25 Data Rate Is 57600 BPS
16 Blinks:	DB25 Data Rate Is 115200 BPS
17 Blinks:	DB25 Data Rate Is 230400 BPS
18 Blinks:	DB25 Data Rate Is 460800 BPS

Top Panel LEDs

Figure 8 shows the location of the LEDs on the top panel; Table 2 lists descriptions for each LED.

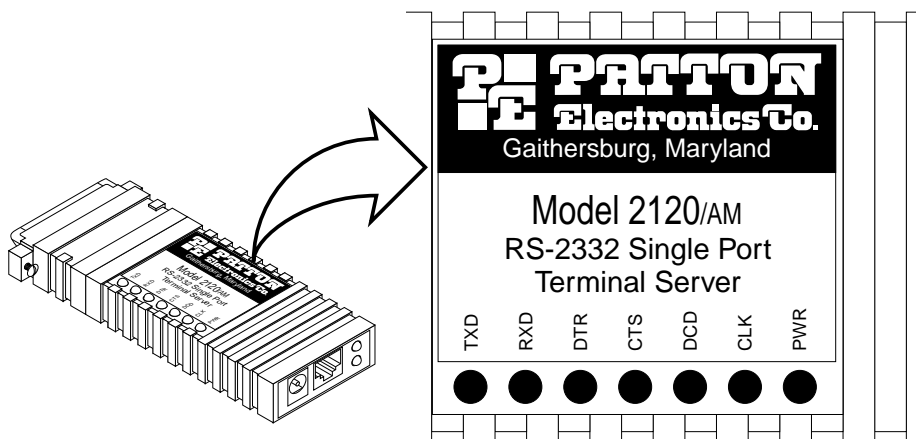

Figure 8. Model 2120 Top Panel LEDs

Table 2: Model 2120 Top Panel LED definitions

LED	Description
TXD	Blinks green to show that data is being transferred through the unit.
RXD	Blinks green to show that data is being received.
DTR	Glow yellow to indicate that the Data Terminal Ready signal is being detected by the Terminal Server.
CTS	Glow yellow to indicate that the Clear to Send signal is being detected by the Terminal Server.
DCD	Glow yellow to indicate that the Data Carrier Detect signal is being detected by the Terminal Server.
CLK	Glow yellow to indicate that a clock is being detected by the Terminal Server.
PWR	Glow green to indicate that power is applied to the unit.

APPENDIX A
MODEL 2120 SINGLE PORT TERMINAL SERVER SPECIFICATIONS

Serial Interface: DB-25 male or female connector

Serial Transmission: RS-232 Asynchronous, 0 to 115.2 kbps (software selectable)

DCE/DTE: DCE or DTE (software selectable)

RS-232 Status Indicators: *TXD, RXD, DTR, CTS, DCD, CLK, and Power*

Ethernet Interface: RJ-45 female connector

Ethernet Standard: 10Base-T (IEEE 802.3)

Ethernet Status Indicators: Ethernet link and status

Protocols Supported: TCP, UDP, IP, ICMP, TELNET, RLOGIN, ARP, DHCP, FTP, TFTP, SLIP, and PPP

Management Services: Monitoring, control, and diagnostics via serial interface or TELNET session

Memory: 1 Mbyte RAM; 512 kbytes FLASH

Power Supply Options: External, universal AC (100–240 VAC) or -48 VDC

Temperature: 32 to 122°F (0 to 50°C)

Altitude: 0 to 15,000 feet (0 to 4,572 meters)

Humidity: Up to 95% non-condensing

Dimensions: 3.5L X 2.1W X 0.78H in. (9.0L X 5.3W X 1.9H cm)

Weight: 0.2 lbs (0.09 kg)

APPENDIX B
MODEL 2120 SINGLE PORT TERMINAL SERVER
SOFTWARE COMMAND DEFINITIONS

In the commands defined below, X = Valid entry/setting for that configuration parameter.

Note Contact your Network Administrator if you have questions regarding configuration parameters required for your application and/or LAN.

B.1 ACTIVATE IMAGE COMMANDS

activateimage

Activates software downloaded to 2120 via FTP. Once new software is activated, session is lost.

Accessibility: N/A

Default: N/A

Valid Entries: N/A

Note Command will not work unless SW has been downloaded to unit.

B.2 BOOT COMMANDS

boot

Remotely performs a soft boot of the 2120. When performed, session is lost.

Accessibility: N/A

Default: N/A

Valid Entries: N/A

Note Command will not work unless SW has been downloaded to unit.

B.3 CONFIGURE COMMANDS

configure

Returns the Configure Help Menu.

Accessibility: N/A

Default: N/A

Valid Entries: N/A

Note Needs to be entered first in all "configure" command strings.

configure activate

Activates/writes changes in configuration parameters permanently in Flash memory of the 2120.

Accessibility: N/A

Default: N/A

Valid Entries: N/A

Note MUST be entered immediately after each “configure” command string to activate configuration changes.

configure clear

Clears changes in configuration parameters prior to “activating” them and reverts back to the previous settings.

Accessibility: N/A

Default: N/A

Valid Entries: N/A

Note Once changes in parameters are activated/written to flash memory using the “configure activate” command, the clear function will have no effect and you must go back in and undo any undesired changes.

configure eia232

Returns the Configure EIA232 Help Menu.

Accessibility: N/A

Default: N/A

Valid Entries: N/A

Note Needs to be entered first in all “configure eia232” command strings.

configure eia232 interface

Returns the Configure EIA232 Interface Help Menu.

Accessibility: N/A

Default: N/A

Valid Entries: N/A

Note Needs to be entered first in all “configure eia232 interface” command strings.

configure eia232 interface charlength X

Sets the RS-232 Character Length (in bits) of the serial interface.

Accessibility: READ/WRITE

Default: 8 (bits)

Valid Entries: 5, 6, 7, 8

configure eia232 interface datarate X

Sets the RS-232 Datarate (in bits per second) of the serial interface.

Accessibility: READ/WRITE

Default: 9600 (bits per second)

Valid Entries: 50*, 75*, 150*, 300*, 600*, 1200*, 2400*, 4800, 9600, 19200, 38400, 57600, 115200, 230400*, 460800*

Note * Denotes data rates not available in the current software version.

configure eia232 interface dtedce X

Sets the RS232 Physical Port of the serial interface.

Accessibility: READ/WRITE

Default: DCE

Valid Entries: DCE, DTE

configure eia232 interface flowcontrol X

Sets the RS-232 Flow Control of the serial interface.

Accessibility: READ/WRITE

Default: none

Valid Entries: none, hardware, xonxoff

configure eia232 interface parity X

Sets the RS-232 Parity of the serial interface.

Accessibility: READ/WRITE

Default: none

Valid Entries: none, odd, low, even, high

configure eia232 interface protocol X

Sets the protocol used by remote devices to communicate with the 2120's serial interface over the LAN.

Accessibility: READ/WRITE

Default: telnet

Valid Entries: telnet, rawtcp

configure eia232 interface stoplevel X

Sets the RS-232 Stop Length (in bits) of the serial interface.

Accessibility: READ/WRITE

Default: 1 (bit)

Valid Entries: 1, 2

configure eia232 rawtcp_telnet

Returns the Configure EIA232 RawTCP/Telnet Help Menu.

Accessibility: N/A

Default: N/A

Valid Entries: N/A

Note Needs to be entered first in all "configure eia232 rawtcp_telnet" command strings.

configure eia232 rawtcp_telnet confromlocena X

Permits the automatic connection request to a remote device over the LAN.

Accessibility: READ/WRITE

Default: no

Valid Entries: yes, no

Note To activate the auto connection feature, this must be set to YES, “configure eia232 rawtcp_telnet conretryfreq” must be set to any number (up to 65535) other than 0, and a valid IP address must be entered into “configure eia232 rawtcp_telnet remip”.

configure eia232 rawtcp_telnet confromremena X

Permits incoming connection requests to the serial interface from a remote device over the LAN.

Accessibility: READ/WRITE

Default: yes

Valid Entries: yes, no

configure eia232 rawtcp_telnet conretryfreq X

Sets the connection retry frequency (in seconds) that automatic connection requests are sent to a remote device.

Accessibility: READ/WRITE

Default: 0 (Disabled)

Valid Entries: 0–65535

Note To activate the auto connection feature, this must be set to any number (up to 65535) other than 0, “configure eia232 rawtcp_telnet confromlocena” must be set to YES, and a valid IP address must be entered into “configure eia232 rawtcp_telnet remip”.

configure eia232 rawtcp_telnet inactiveto X

Sets the period of time (in minutes) that the 2120 will close an inactive connection to the serial interface.

Accessibility: READ/WRITE

Default: 15 (minutes)

Valid Entries: 0–10080

Note Entering a 0 for this parameter will disable this feature and allow a connection to the serial interface for an unlimited period of time.

configure eia232 rawtcp_telnet locport X

Sets the TCP port number used to establish a connection with the serial interface over the LAN.

Accessibility: READ/WRITE

Default: 404

Valid Entries: 0–65535

Note This TCP port number must be used as the TCP destination port number by any device attempting to connect to the 2120's serial interface over the LAN.

configure eia232 rawtcp_telnet locpwd X

Sets/activates the local password required for remote devices/applications attempting a connection request to the serial interface over the LAN.

Accessibility: READ/WRITE

Default: UNDEFINED (no entry)

Valid Entries: Any alphanumeric entry with a string size up to 32 bytes

configure eia232 rawtcp_telnet locuserid X

Sets/activates the local user ID required for remote devices/applications attempting a connection request to the serial interface over the LAN.

Accessibility: READ/WRITE

Default: UNDEFINED (no entry)

Valid Entries: Any alphanumeric entry with a string size up to 32 bytes

configure eia232 rawtcp_telnet remip X

Sets the destination IP address used when automatic connection requests are sent to a remote device over the LAN.

Accessibility: READ/WRITE

Default: 1.1.1.8

Valid Entries: Any in IP address format

Note To activate the auto connection feature, "configure eia232 rawtcp_telnet confromlocena" must be set to YES and "configure eia232 rawtcp_telnet conretryfreq" must be set to any number (up to 65535) other than 0.

configure eia232 rawtcp_telnet remport X

Sets the destination TCP port number used when automatic connection requests are sent to a remote device over the LAN.

Accessibility: READ/WRITE

Default: 23 (Telnet)

Valid Entries: 0–65535

Note This is used in conjunction with the automatic connection feature.

configure eia232 rawtcp_telnet rempwd X

Sets/activates the password sent with automatic connection requests to a remote device/application over the LAN.

Accessibility: READ/WRITE

Default: UNDEFINED (no entry)

Valid Entries: Any alphanumeric entry with a string size up to 32 bytes

configure eia232 rawtcp_telnet remuserid X

Sets/activates the User ID sent with automatic connection requests to a remote device/application over the LAN.

Accessibility: READ/WRITE

Default: UNDEFINED (no entry)

Valid Entries: Any alphanumeric entry with a string size up to 32 bytes

configure eia232 rawtcp_telnet sestermchar X

Sets character string that is required to terminate a connection to the serial interface.

Accessibility: READ/WRITE

Default: 4 (Control-D)

Valid Entries: 0–65535

Note 4 (Control-D) is recommended.

configure resetnv

Performs a software reset (to factory defaults) of all non-volatile configuration parameters. When performed, session is lost.

Accessibility: N/A

Default: N/A

Valid Entries: N/A

Note Will not reset factory assigned MAC/NIC address, but will reset the IP address.

configure system

Returns the Configure System Help Menu.

Accessibility: N/A

Default: N/A

Valid Entries: N/A

Note Needs to be entered first in all “configure system” command strings.

configure system bootmessdispena X

Permits the display of the Boot Message on the serial interface.

Accessibility: READ/WRITE

Default: yes

Valid Entries: yes, no

Note Set to NO if the serial device is affected/confused by the boot message.

configure system defgatewayipddr X

Sets the IP address of the default gateway.

Accessibility: READ/WRITE

Default: 0.0.0.0 (disabled)

Valid Entries: Any in MAC address format

Note The 2120 will attempt to find and use the MAC address of the default gateway when the MAC address of the destination IP address cannot be found.

configure system dhcpena X

Permits DHCP client operation.

Accessibility: READ/WRITE

Default: yes

Valid Entries: yes, no

Note When set to YES, the 2120 will automatically request and use an IP address assigned by the DHCP Server. This feature will not function unless there is an active DHCP Server on the LAN.

configure system ipaddr X

Sets IP address of the 2120.

Accessibility: READ/WRITE

Default: 2.2.2.2

Valid Entries: Any in IP address format.

Note If there is an active DHCP Server on the LAN, configure system dhcpena must be set to NO or the IP address entered here will be overwritten with the IP address assigned by the DHCP server.

configure system mac X

Changes MAC address of the 2120.

Accessibility: READ/WRITE

Default: Factory assigned MAC/NIC address.

Valid Entries: Any in MAC address format.

Note MAC address can be changed, but will not reset when hard (Dip Switch #1) or soft (configure resetnv) configuration resets are performed.

configure system manena X

Permits configuration of the 2120 via a remote Telnet session over the LAN.

Accessibility: READ/WRITE

Default: yes

Valid Entries: yes, no

Note If disabled, configuration of the 2120 is only possible via the serial interface.

configure system manactiveto X

Sets the period of time (in minutes) that the 2120 will close an inactive Telnet session.

Accessibility: READ/WRITE

Default: 15 (minutes)

Valid Entries: 0 – 10080

Note Entering a 0 for this parameter will disable this feature and allow a Telnet session for an unlimited period of time.

configure system manpwd X

Sets/activates the password required by users attempting a Telnet session with the 2120.

Accessibility: READ/WRITE

Default: UNDEFINED (no entry)

Valid Entries: Any alphanumeric entry with a string size up to 32 bytes

configure system manuserid X

Sets/activates the user ID required by users attempting a Telnet session with the 2120.

Accessibility: READ/WRITE

Default: UNDEFINED (no entry)

Valid Entries: Any alphanumeric entry with a string size up to 32 bytes

configure system prompt X

Sets system command prompt.

Accessibility: READ/WRITE

Default: TS>

Valid Entries: Any alphanumeric entry with a string size up to 32 bytes

configure system subnet X

Sets the Subnet Mask of the 2120.

Accessibility: READ/WRITE

Default: 255.255.255.0

Valid Entries: Any in Subnet Mask format.

B.4 EIAONCLOSE COMMANDS

eiaonclose

Remotely closes the connection to the serial interface.

Accessibility: N/A

Default: N/A

Valid Entries: N/A

Note This may be needed if the inactivity timeout feature is disabled.

B.5 FTP COMMANDS

ftp

Enables the 2120 to communicate with FTP servers over the LAN for viewing and downloading files (i.e. new 2120 software releases).

Accessibility: N/A

Default: N/A

Valid Entries: N/A

Note See "Software Installation Instructions" on page 20.

B.6 PING COMMANDS

ping

Enables the 2120 to ping other devices on the LAN.

Accessibility: N/A

Default: N/A

Valid Entries: N/A

B.7 RAWTCP COMMANDS

rawtcp

Enables the 2120 to initiate a Raw-TCP session with remote devices over the LAN.

Accessibility: N/A

Default: N/A

Valid Entries: N/A

B.8 SHOW COMMANDS

show

Returns the Show Help Menu.

Accessibility: N/A

Default: N/A

Valid Entries: N/A

Note Needs to be entered first in all “show” command strings.

show eia232

Returns the Show EIA232 Help Menu.

Accessibility: N/A

Default: N/A

Valid Entries: N/A

Note Needs to be entered first in all “show eia232” command strings.

show eia232 interface

Returns the Show EIA232 Interface Help Menu.

Accessibility: N/A

Default: N/A

Valid Entries: N/A

Note Needs to be entered first in all “show eia232 interface” command strings.

show eia232 interface all

Returns all current EIA232 interface settings.

Accessibility: READ ONLY

show eia232 interface charlength

Returns current RS-232 Character Length setting.

Accessibility: READ ONLY

show eia232 interface datarate

Returns current RS-232 Datarate setting.

Accessibility: READ ONLY

show eia232 interface dtedce

Returns current RS-232 DTE/DCE Physical Port setting.

Accessibility: READ ONLY

show eia232 interface flowcontrol

Returns current RS-232 Flow Control setting.

Accessibility: READ ONLY

show eia232 interface parity

Returns current RS-232 Parity setting.

Accessibility: READ ONLY

show eia232 interface protocol

Returns current RS-232 Protocol setting.

Accessibility: READ ONLY

show eia232 interface stoptlength

Returns current RS-232 Stop Length setting.

Accessibility: READ ONLY

show eia232 rawtcp_telnet

Returns Raw-TCP/Telnet Help Menu.

Accessibility: N/A

Default: N/A

Valid Entries: N/A

Note Needs to be entered first in all “show eia232 rawtcp_telnet” command strings.

show eia232 rawtcp_telnet all

Returns all current EIA232 Raw-TCP/Telnet settings.

Accessibility: READ ONLY

show eia232 rawtcp_telnet confromlocena

Returns current Connection From Local Enable setting.

Accessibility: READ ONLY

show eia232 rawtcp_telnet confromremena

Returns current Connection From Remote Enable setting.

Accessibility: READ ONLY

show eia232 rawtcp_telnet conretryfreq
Returns current Connection Retry Frequency setting.
Accessibility: READ ONLY

show eia232 rawtcp_telnet inactiveto
Returns current Inactive Timeout setting.
Accessibility: READ ONLY

show eia232 rawtcp_telnet locport
Returns current Local Port setting.
Accessibility: READ ONLY

show eia232 rawtcp_telnet locpwd
Returns current Local Password setting.
Accessibility: READ ONLY

show eia232 rawtcp_telnet locuserid
Returns current Local User ID setting.
Accessibility: READ ONLY

show eia232 rawtcp_telnet remip
Returns current Remote IP Address setting.
Accessibility: READ ONLY

show eia232 rawtcp_telnet remport
Returns current Remote Port setting.
Accessibility: READ ONLY

show eia232 rawtcp_telnet rempwd
Returns current Remote Password setting.
Accessibility: READ ONLY

show eia232 rawtcp_telnet remuserid
Returns current Remote User ID setting.
Accessibility: READ ONLY

show eia232 rawtcp_telnet sestertermchar
Returns current Session Termination Character setting.
Accessibility: READ ONLY

show eia232 rawtcp_telnet tcpconstate
Returns current TCP Connection State.
Accessibility: READ ONLY
Default: listen
Possible States: listen, established

show system

Returns System Help Menu.

Accessibility: N/A

Default: N/A

Valid Entries: N/A

Note Needs to be entered first in all “show system” command strings.

show system all

Returns all current System settings.

Accessibility: READ ONLY

show system bootmessdispena

Returns current Boot Message Display Enable setting.

Accessibility: READ ONLY

show system defgatewayipddr

Returns current Default Gateway IP Address setting.

Accessibility: READ ONLY

show system dhcpena

Returns current DHCP Enable setting.

Accessibility: READ ONLY

show system dhcpstate

Returns current DHCP client state.

Accessibility: READ ONLY

Default: select

Possible States: select, initialize, bound

show system dhcppassedtime

Returns the amount of time (in seconds) since the lease on the IP address started.

Accessibility: READ ONLY

Default: 0 (seconds)

Possible Values: 0–65535

show system dhcprenewtime

Returns when (in seconds) the lease on the current IP address must be renewed.

Accessibility: READ ONLY

Default: 0 (seconds)

Possible Values: 0–65535

show system dhcprebindtime

Returns when (in seconds) rebind must occur between the IP and MAC address.

Accessibility: READ ONLY

Default: 0 (seconds)

Possible Values: 0–65535

show system dhcpexpiretime

Returns when (in seconds) the lease on the current IP address will expire.

Accessibility: READ ONLY

Default: 0 (seconds)

Possible Values: 0–65535

show system ipaddr

Returns current IP address setting.

Accessibility: READ ONLY

show system mac

Returns current MAC/NIC address setting.

Accessibility: READ ONLY

show system manena

Returns current management enable setting.

Accessibility: READ ONLY

show system maninactiveto

Returns current management inactive timeout setting.

Accessibility: READ ONLY

show system manpwd

Returns current management password setting.

Accessibility: READ ONLY

show system manuserid

Returns current management user ID setting.

Accessibility: READ ONLY

show system prompt

Returns current prompt setting.

Accessibility: READ ONLY

show system subnet

Returns current subnet mask setting.

Accessibility: READ ONLY

show system swversion

Returns current software version.

Accessibility: READ ONLY

APPENDIX C
MODEL 2120 SINGLE PORT TERMINAL SERVER
APPLICATION NOTES

Provided below are sample test configurations and applications that can be used as a reference when configuring the Model 2120 for various applications.

*** THIS SECTION IS UNDER CONSTRUCTION ***