

Stick T3 Mini 10,000 hours

Compact Fluorescent Lamps Integrated
9W, 11W, 15W, 20W and 23W

Product information

The T3 10,000 hours Mini stick range offers low energy consumption in a compact size. Stick shaped lamps provide an energy saving alternative for almost all applications where incandescent bulbs are currently used – ensuring excellent light quality and reliable energy savings.

Features

Compact Fluorescent Lamps (CFL) have an important role to play in the future of lighting, helping to protect the environment by using less energy and creating less CO₂ emissions. In addition, CFL lamps contribute to the reduction of maintenance costs, ensuring that financial benefits are enjoyed alongside environmental benefits.

There are a variety of performance advantages afforded by GE Lighting CFL lamps. They use almost 80% less energy and last ten times longer than their incandescent predecessors, are rated energy class 'A' and offer high quality light.

With continuing technological advancements and miniaturisation, today's T3 CFL lamps are similar to the incandescent lamps that they replace to ensure that they are discreet – yet high performing.

- 10,000 hours life
- Small dimensions
- Standard warm-up
- Switch on feature
- 'A' energy class



Application areas

Stick T3 Mini 10,000 hours lamps are recommended for general indoor and outdoor (in enclosed fittings) applications such as:

- Home lighting
- Retail lighting
- Hotels
- Restaurants
- Corridors, hallways
- Gardens, courtyards

Product range

T3 Stick Mini lamps are available in a full range of:

- 9, 11, 15, 20 and 23 wattages
- E14, E27, B22 caps
- Warm (2700K), Cool (4000K) and Daylight (6500K) colours
- Box and blister packs



Compliance

Standards

- IEC 60061-1: Lamp caps and holders together with gauges for the control of interchangeability and safety
- IEC or EN 60969: Self ballasted lamps for general lighting services – performance requirements
- IEC or EN 60968: Self-ballasted lamps for general lighting services – safety requirements
- CIE S 009/E:2002: Photobiological safety of lamps and lamp systems
- EN 61547: Requirement for general lighting purposes – EMC immunity requirement
- EN 55015 or CISPR 15: Limits and methods of measurement of radio disturbance characteristics of electrical lighting and similar equipment
- EN 61000-3-2: Electromagnetic compatibility (EMC) – Part 3-2: Limits – limits for harmonic current emissions (equipment input current up to and including 16A per phase)
- EN 61000-3-3: Electromagnetic compatibility (EMC) – Part 3-3: Limits – limitation of voltage fluctuations and flicker in low-voltage supply systems for equipment with rated current up to 16A
- EN 62493 Assessment of lighting equipment related to human exposure to electromagnetic fields

European Directives:

- CE mark: 93/68/EEC; LVD: 2006/95/EC; EMC: 2004/108/EC, Ecodesign 2005/32/EC, ROHS 2011/65/EU
- Energy Labelling: Directive 2010/30/EU, 874/2012/EU energy labelling of electrical lamps and luminaires
- RoHS: Directive 2011/65/EU on Restrictions of the use of certain Hazardous Substances (RoHS)
- WEEE: Directive 2012/19/EU on Waste Electrical and Electronic Equipment (WEEE)
- REACH: Directive 2006/1907/EC on Registration, Evaluation, Authorisation and Restriction of Chemicals (REACH)
- ErP ecodesign: Directive 2005/32/EC, 2009/244/EC ecodesign requirements (of Energy-related Products) for non-directional household lamps

Basic data

Rated Power* [W]	Volts [V]	Cap	Product description	Product Code Box pack	Product Code Blister pack	Rated Lumen* [lm]	CCT [K]	CRI [Ra]	Rated* Life [h]	Length [mm]	Diameter [mm]	EuP Inca Watt Equivalent	EEC	Energy consumption [kWh/1000h]	Pack Qty
9	230	E14	FLE9TBX/T3/827/E14	71298		470	2700	82	10000	120	45	42	A	8.96	8
9	230	E14	FLE9TBX/T3/865/E14	71382		450	6500	82	10000	120	45	41	A	8.97	10
9	230	E27	FLE9TBX/T3/827/E27	71297		470	2700	82	10000	111	45	42	A	8.96	8
9	230	E27	FLE9TBX/T3/840/E27	71299		470	4000	82	10000	111	45	42	A	9.10	10
9	230	E27	FLE9TBX/T3/865/E27	71300		450	6500	82	10000	111	45	41	A	8.97	10
9	230	B22	FLE9TBX/T3/827/B22	71100		470	2700	82	10000	110	45	42	A	8.96	8
11	230	E14	FLE11TBX/T3/827/E14	71296	89864	590	2700	82	10000	132	45	50	A	10.54	8
11	230	E14	FLE11TBX/T3/865/E14	71501		560	6500	82	10000	132	45	48	A	10.71	10
11	230	E27	FLE11TBX/T3/827/E27	71117		590	2700	82	10000	123	45	50	A	10.54	8
11	230	E27	FLE11TBX/T3/840/E27	71500		590	4000	82	10000	123	45	50	A	10.56	10
11	230	E27	FLE11TBX/T3/865/E27	71125		560	6500	82	10000	123	45	48	A	10.71	8
11	230	B22	FLE11TBX/T3/827/B22	71118		590	2700	82	10000	122	45	50	A	10.54	8
15	230	E27	FLE15TBX/T3/827/E27	71116	89863	850	2700	82	10000	134	45	67	A	14.38	8
15	230	E27	FLE15TBX/T3/840/E27	72375		850	4000	82	10000	134	45	67	A	14.46	10
15	230	E27	FLE15TBX/T3/865/E27	72376		810	6500	82	10000	134	45	65	A	14.55	10
20	230	E27	FLE20TBX/T3/827/E27	72379		1185	2700	82	10000	146	45	88	A	18.20	8
20	230	E27	FLE20TBX/T3/840/E27	72381		1155	4000	82	10000	146	45	86	A	18.04	10
20	230	E27	FLE20TBX/T3/865/E27	72382		1155	6500	82	10000	146	45	86	A	18.32	10
20	230	B22	FLE20TBX/T3/827/B22	72380		1185	2700	82	10000	145	45	88	A	18.20	8
23	230	E27	FLE23QBX/T3/827/E27	71124		1400	2700	82	10000	153	51	100	A	22.15	8
23	230	E27	FLE23QBX/T3/840/E27	72383		1400	4000	82	10000	153	51	100	A	22.19	8
23	230	B22	FLE23QBX/T3/827/B22	71119		1400	2700	82	10000	152	51	100	A	22.15	8

*Rated wattage, life and lumen are equivalent to nominal values, which are indicated on product packaging

Survival rate and lumen maintenance

Life Expectancy and Lumen Maintenance

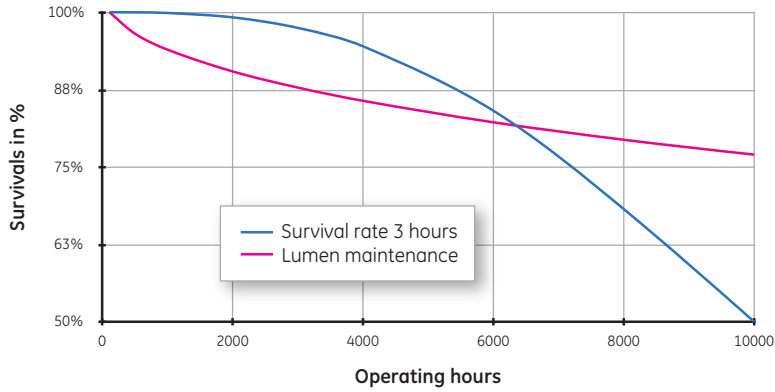

Hours	Survival rate 3 hours	Lumen maintenance
100	1.00	1.00
2,000	0.99	0.90
4,000	0.94	0.86
6,000	0.84	0.82
8,000	0.68	0.79
10,000	0.49	0.77

Test condition: 50Hz 230V 3 hours cycling - according to IEC60969

Dimensions

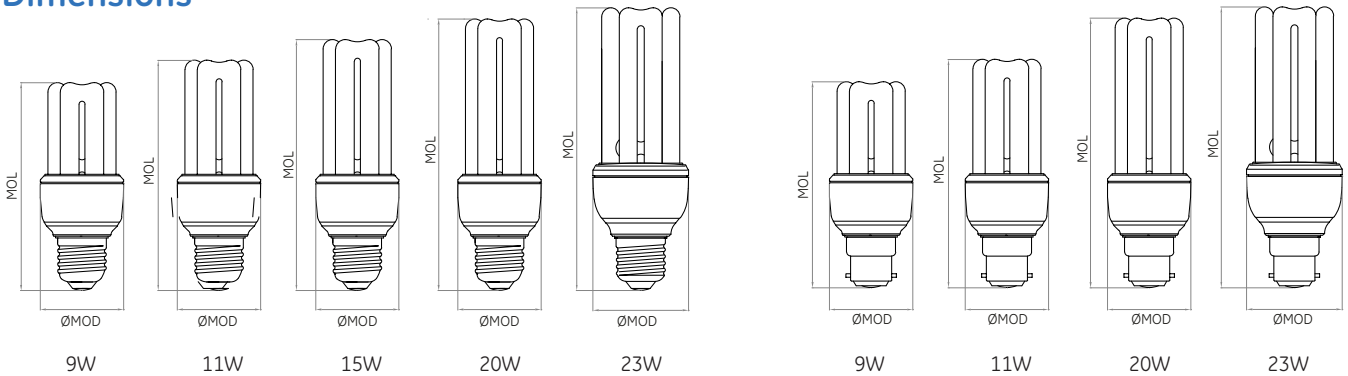

E27 cap		
	MOL [mm]	MOD [mm]
9W	111	45
11W	123	45
15W	134	45
20W	146	45
23W	153	51

B22 cap		
	MOL [mm]	MOD [mm]
9W	110	45
11W	122	45
20W	145	45
23W	152	51

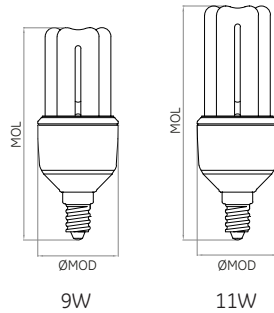

E14 cap		
	MOL [mm]	MOD [mm]
9W	120	45
11W	132	45

Spectral power distribution

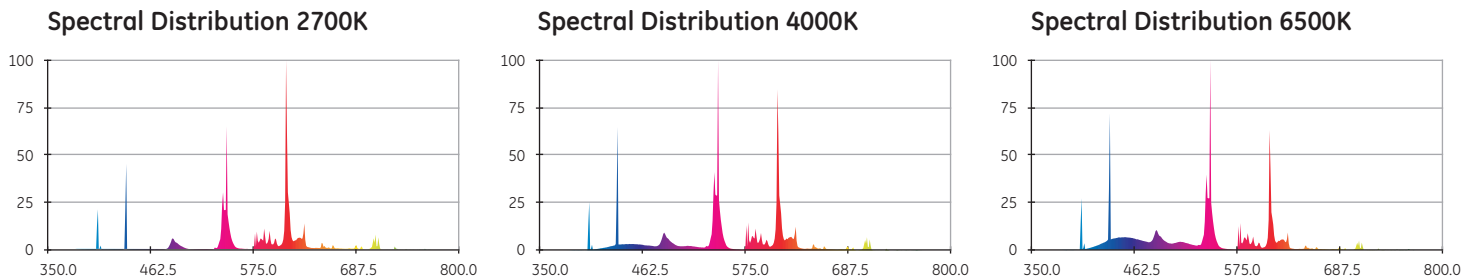

Lumen output versus ambient temperature

Photometrical and light parameters of a fluorescent lamp depend on the mercury vapor pressure inside the lamp. Mercury vapor pressure in turn is controlled by temperature. When installed in a luminaire, the temperature of the air surrounding the lamp cap changes and this can affect the light output of the lamp. The effects of changes in ambient temperature for a typical lamp are shown on the graph.

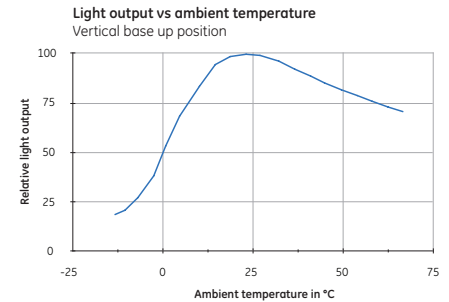

Additional Information - ErP Compliance



Incandescent watt equivalence: select the preferred wattage to enjoy the same light output as the original incandescent bulb while at the same time achieving significant energy savings. The Basic Data table and the updated EuP packaging include the CFL-Incandescent wattage equivalences according to the new EuP luminous flux standards.



Switching cycle: switching endurance is minimum 30,000 cycles based on official EU standard – one minute on, three minutes off.

T3 Stick Mini 10,000: switching cycle: 30,000



Starting time: the time needed for the lamp to start fully and remain alight. GE Lighting's CFL lamps are usually instant light on. Starting categories are: instant on (<0.3sec), quick (0.3-1sec), standard (1-1.5sec).

T3 Stick Mini 10,000 hours starting time: standard



Warm-up: GE Lighting's CFL lamps are usually characterised by fast warm-up times and an instant light on feature. Warm-up categories at 60% lumen are: fast (<30sec), standard (30-60sec) and slow (60-120sec).

T3 Stick Mini 10,000: warm-up <40sec



Dimming: not recommended to use with dimmers.



All lamps operate on 230 Volt (+/-10%), 50 Hertz

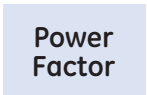

Power Factor: ratio of the measured active input power to the product of the supply voltage (r.m.s.) and the supply current (r.m.s.) measures how efficiently the current is being converted into real power. Lamps of power factor >0.9 are referred to as High Power Factor lamps, below that as Low Power Factor lamps. All lamps above 25 wattage sold in EU need be High Power Factor lamp. **T3 Stick Mini 10,000 hours power factor: >= 0,55**

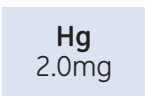

Mercury content: GE Lighting's CFL lamps contain a minimised level of mercury, some of our best-in class lamps as low as 0.9 mg vs. the max. 2.5mg allowed by the EU RoHS.

T3 Stick Mini 10,000: mercury content 2mg



Website: Instructions on how to dispose of lamps at end of life or in the case of accidental lamp breakage are available on the GE Lighting website.

Application information

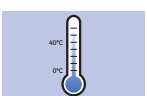

Ambient temperature range: temperature at which a lighting product can be safely used and can meet the claimed rated life. Outside of this temperature range the product might still operate, although the life could be reduced. **Stick T3 Mini 10,000 hours ambient operating temperature range: 0-40 °C**

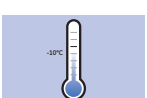

Minimum starting temperature: the lowest temperature condition at which the product can reliably start at within 3 sec at 230V.

Stick T3 Mini 10,000 hours minimum starting temperature: -10°C

Cautionary notices



Lamp may shatter and cause injury if broken.

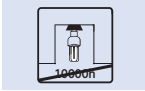

Usage in recessed fixtures could result in reduced life.

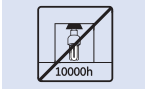

Do not use the lamp in enclosed fixtures.

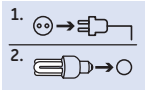

Switch off electricity before changing the bulb.

Safety notice



Do not grab the tubes when install/screw-in the lamp.