

Ultra-Fast Soft Recovery Diode Module

Description

Ultra-FRD module devices are optimized to reduce losses and EMI/RFI in high frequency power conditioning electrical systems. These diode modules are ideally suited for power converters, motors drives and other applications where switching losses are significant portion of the total losses.



Features

- ☞ Repetitive Reverse Voltage : $V_{RRM} = 400V$
- ☞ Low Forward Voltage Drop : $V_F(\text{typ.}) = 1.05V$
- ☞ Average Forward Current : $I_F(\text{AV.}) = 125A @ T_c = 100^\circ C$
- ☞ Ultra-Fast Reverse Recovery Time : $t_{rr}(\text{typ.}) = 70 \text{ ns}$
- ☞ Extensive Characterization of Recovery Parameters
- ☞ Reduced EMI and RFI
- ☞ Isolation Type Package

Applications

Motor Drives, Free wheel use, High Power Converters, Welders, Various Switching and Telecommunication Power Supply.

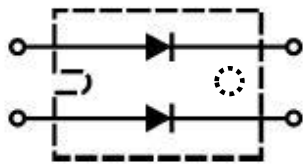
Equivalent Circuit and Package

Equivalent Circuit

Package : SOT-227

Please see the package Out line information

Absolute Maximum Ratings @ $T_j=25^\circ C$ (Per Leg)

Symbol	Parameter	Conditions	Ratings	Unit
V_{RRM}	Repetitive Peak Reverse Voltage		400	V
$V_{R(DC)}$	Reverse DC Voltage		320	V
$I_{F(AV)}$	Average Forward Current	@ $T_c = 25^\circ C$	Resistive Load 250	A
		@ $T_c = 100^\circ C$	125	A
I_{FSM}	Surge(non-repetitive) Forward Current	One Half Cycle at 60Hz, Peak Value	2600	A
I^2_t	I^2t for Fusing	Value for One Cycle Current, $t_w = 8.3\text{ms}, T_j = 25^\circ C$ Start	$30.5 * 10^3$	A^2s
T_j	Junction Temperature		-40 ~ 150	$^\circ C$
T_{stg}	Storage Temperature		-40 ~ 125	$^\circ C$
V_{isol}	Isolation Voltage	@ AC 1 minutes	2500	V
P_d	Maximum Power Dissipation		460	W
-	Mounting Torque		1.45	N.m
-	Terminal Torque		1.45	N.m
-	Weight	Typical Including Screws	30	g

Thermal Characteristics

Symbol	Parameter	Conditions	Values			Unit
			Min.	Typ.	Max.	
$R_{th(j-c)}$	Thermal Resistance(Non Isolation Type)	Junction to Case	-	-	0.27	$^{\circ}\text{C}/\text{W}$

Electrical Characteristics @ $T_j=25^{\circ}\text{C}$ (unless otherwise specified)

Symbol	Parameter	Conditions	Values			Unit	
			Min.	Typ.	Max.		
V_R	Cathode Anode Breakdown Voltage	$I_R = 100\mu\text{A}$	400	-	-	V	
V_{FM}	Maximum Forward Voltage	$I_F = 125\text{A}, T_c = 25^{\circ}\text{C}$	-	1.05	1.3	V	
		$I_F = 125\text{A}, T_c = 100^{\circ}\text{C}$	-	0.95	1.1	V	
I_{RRM}	Repetitive Peak Reverse Current	$T_c = 100^{\circ}\text{C}, V_{RRM}$ applied	-	-	1.0	mA	
t_{rr}	Reverse Recovery Time	$T_c = 25^{\circ}\text{C}$	-	70	100	ns	
		$T_c = 100^{\circ}\text{C}$	-	100	-	ns	
I_{rr}	Diode Peak Reverse Recovery Current	$I_F = 125\text{A}, V_R = 200\text{V}$ $di/dt = -250\text{A}/\mu\text{s}$,	$T_c = 25^{\circ}\text{C}$	-	8	12	A
			$T_c = 100^{\circ}\text{C}$	-	17.5	-	A
Q_{rr}	Diode Reverse Recovery Charge	Inductive load	$T_c = 25^{\circ}\text{C}$	-	280	600	nC
			$T_c = 100^{\circ}\text{C}$	-	750	-	nC
tb/ta	Softness	$I_F = 125\text{A}, V_R = 200\text{V}, di/dt = -250\text{A}/\mu\text{s}$	0.8	-	-		

Performance Curves

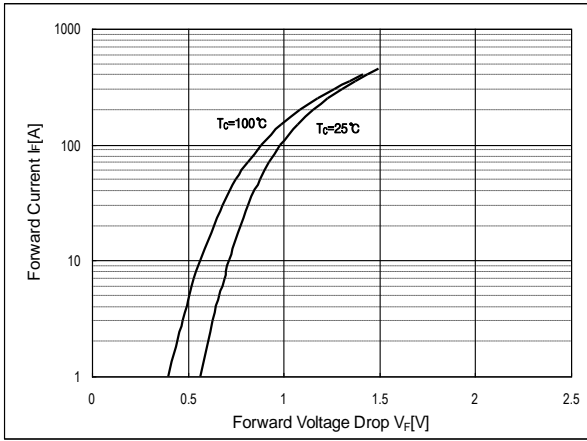

Fig. 1 : Typical Forward Voltage Drop vs. Instantaneous Forward Current

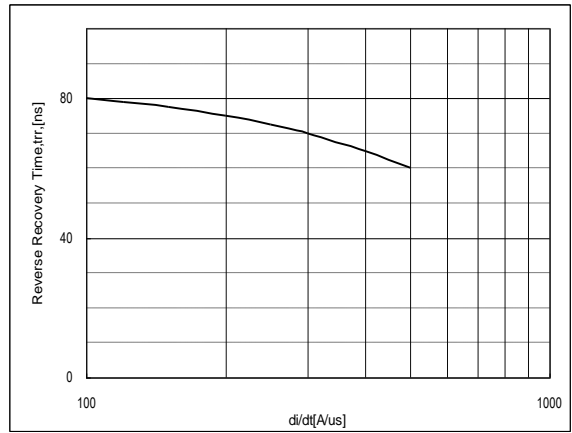

Fig. 2 : Typical Reverse Recovery Time vs. -di/dt

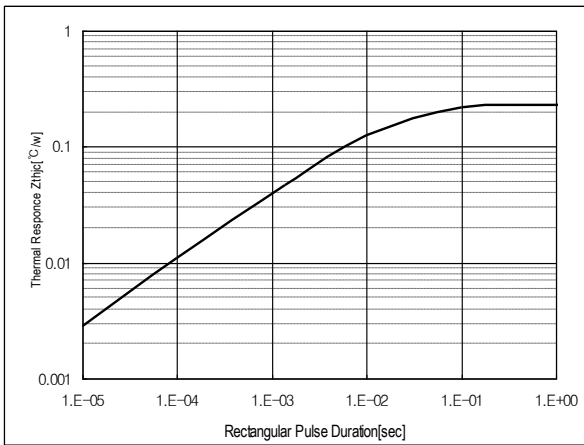

Fig. 3 : Transient Thermal Impedance(Z_{thjc}) Characteristics

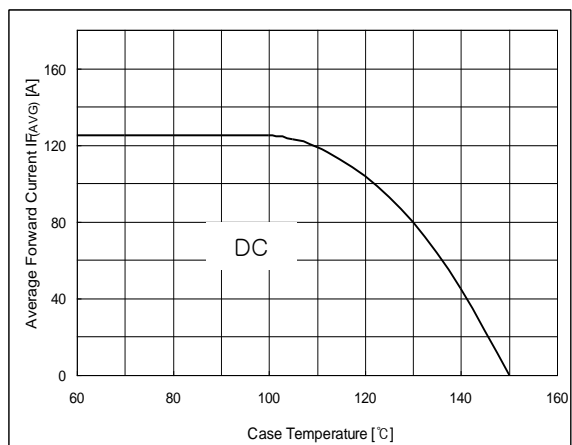

Fig. 4 : Forward Current Derating Curve

Package Out Line Information

SOT-227



Marking Spec.

Device Name	Marking code
DWM2F125N040	DWM125X2-04N

UNIT : mm

