

SINGLE TURN CERMET TRIMMERS

# RJ-4

RoHS compatible

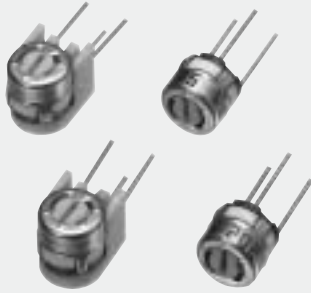

## FEATURES

- Lead-free soldering, Cadmium-free
- Compact with power rating of 0.5 W
- Precious metal alloy wiper

### INTERNAL STRUCTURE

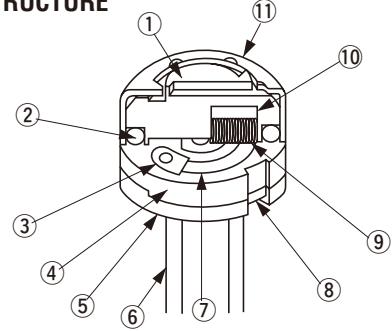

Part name		Material	Flammability
①	Rotor	PBT (Polybutyleneterephthalate)	UL-94HB
②	“O” ring	Silicone rubber	
③	Electrode	Ag-Pd cermet	—
④	Base element	Ceramic	
⑤	Base	PPS (Polyphenylenesulphide)	UL-94V-0
⑥	Terminal pin	Sn-Pb Copper alloy, Solder-plated	—
		Sn Copper alloy, Tin-plated	
⑦	Resistive element	RuO <sub>2</sub> cermet	
⑧	Adhesive	Epoxy	
⑨	Wiper	Multi metal alloy	
⑩	Rubber cushion	Silicone rubber	
⑪	Cover	Stainless steel	

CFCs, Halon, Carbon tetrachloride and designated bromic flame retardant PBBOs and PBBs are not used in our products.

## PART NUMBER DESIGNATION

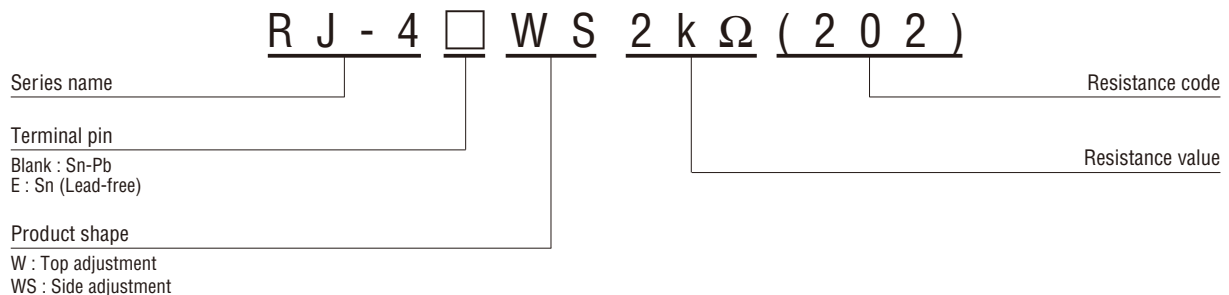

✳ Please refer to the LIST OF PART NUMBERS when placing orders.

### LIST OF PART NUMBERS

Adjustment position	Form of packaging		Pieces in package
	Vinyl bag		
	Sn-Pb	Sn (Lead-free)	
Top adjustment	RJ-4W	RJ-4EW	50 pcs./pack
Side adjustment	RJ-4WS	RJ-4EWS	

### <Nominal resistance values>

↻ 10 Ω	↻ 20 Ω	50 Ω	100 Ω	200 Ω	500 Ω	1 kΩ	2 kΩ	5 kΩ
10 kΩ	20 kΩ	50 kΩ	100 kΩ	200 kΩ	500 kΩ	1 MΩ	2 MΩ	

Fig. 1

The products indicated by ↻ mark are manufactured upon receipt of order basis.

- \* : The above part numbers are all available with the respective combination of <Nominal resistance values> (Fig. 1).
- \* : Verify the above part numbers when placing orders.

### ELECTRICAL CHARACTERISTICS

Nominal resistance range	10 Ω ~ 2 MΩ
Resistance tolerance	± 10 %
Power ratings	0.5 W (70 °C) 0 W (120 °C)
Resistance law	Linear law (B)
Maximum input voltage	DC200 V or power rating, whichever is smaller
Maximum wiper current	100 mA or power rating, whichever is smaller
Effective electrical angle	200 ° (1 turn)
End resistance	1 % or 2 Ω, whichever is greater
C.R.V.	1 % or 3 Ω, whichever is greater
Operating temp. range	-55 ~ 120 °C
Temp. coefficient	10 Ω ~ 50 Ω : ± 250 10 <sup>-6</sup> /°C maximum 100 Ω ~ 2 MΩ : ± 100 10 <sup>-6</sup> /°C maximum
Insulation resistance	1000 MΩ minimum (DC500 V)
Dielectric strength	AC500 V, 60 s
Net weight	Approx. 0.26 g (RJ-4W, EW) Approx. 0.35 g (RJ-4WS, EWS)

### MECHANICAL CHARACTERISTICS

Mechanical angle	230 ° (1 turn)
Operating torque	15 mN·m {153 gf·cm} maximum
Stop strength	45 mN·m {459 gf·cm} minimum
Rotational life	200 cycles 10 Ω ~ 200 Ω [Δ R/R ≤ ± (0.5 Ω + 3 %)] 500 Ω ~ 2 MΩ [Δ R/R ≤ ± (0.5 Ω + 2 %)]
Terminal strength	10 N {1.02 kgf} minimum (Tensile strength)
Thrust to rotor	10 N {1.02 kgf} minimum
Solderability	Sn-Pb : 235 °C, 2 s Sn (Lead-free) : 245 ± 3 °C, 2 ~ 3 s

{ } : Reference only

### ENVIRONMENTAL CHARACTERISTICS

Test item	Test conditions	Specifications
Thermal shock	-65 ~ 125 °C (0.5 h), 5 cycles	[Δ R/R ≤ 1 %] [S.S. ≤ 1 %]
Humidity	-10 ~ 65 °C (Relative humidity 80 ~ 98 %), 10 cycles, 240 h	[Δ R/R ≤ 1 %]
Shock	981 m/s <sup>2</sup> , 6 ms 6 directions for 3 times each	[Δ R/R ≤ 1 %] [S.S. ≤ 1 %]
Vibration	Amplitude 1.52 mm or Acceleration 196 m/s <sup>2</sup> , 10 ~ 2000 Hz, 3 directions, 12 times each	[Δ R/R ≤ 1 %] [S.S. ≤ 1 %]
Load life	70 °C, 0.5 W 1000 h	[Δ R/R ≤ 3 %] [S.S. ≤ 1 %]
Low temp. operation	-55 °C, 2 h	[Δ R/R ≤ 2 %] [S.S. ≤ 2 %]
High temp. exposure	120 °C, 250 h	[Δ R/R ≤ 3 %] [S.S. ≤ 2 %]
Immersion seal	85 °C, 60 s	No leaks (No continuous bubbles)
Soldering heat	Sn-Pb 350 °C, 3 s Sn Flow : 260 ± 3 °C, 5 ~ 6 s, twice Manual soldering : 380 ± 10 °C, 3 ~ 4 s	[Δ R/R ≤ 1 %]

Δ R/R : Change in total resistance  
S.S. : Setting stability

■ **MAXIMUM INPUT RATINGS**

Nominal resistance values (Ω)	Resistance code	Maximum input voltage (V)	Maximum wiper current (mA)
<ul style="list-style-type: none"> <li>➔ 10</li> <li>➔ 20</li> <li>50</li> <li>100</li> <li>200</li> <li>500</li> </ul>	<ul style="list-style-type: none"> <li>100</li> <li>200</li> <li>500</li> <li>101</li> <li>201</li> <li>501</li> </ul>	<ul style="list-style-type: none"> <li>1.00</li> <li>2.00</li> <li>5.00</li> <li>7.07</li> <li>10.0</li> <li>15.8</li> </ul>	<ul style="list-style-type: none"> <li>100</li> <li>100</li> <li>100</li> <li>70.7</li> <li>50.0</li> <li>31.6</li> </ul>
<ul style="list-style-type: none"> <li>1 k</li> <li>2 k</li> <li>5 k</li> <li>10 k</li> <li>20 k</li> <li>50 k</li> </ul>	<ul style="list-style-type: none"> <li>102</li> <li>202</li> <li>502</li> <li>103</li> <li>203</li> <li>503</li> </ul>	<ul style="list-style-type: none"> <li>22.4</li> <li>31.6</li> <li>50.0</li> <li>70.7</li> <li>100</li> <li>158</li> </ul>	<ul style="list-style-type: none"> <li>22.4</li> <li>15.8</li> <li>10.0</li> <li>7.07</li> <li>5.00</li> <li>3.16</li> </ul>
<ul style="list-style-type: none"> <li>100 k</li> <li>200 k</li> <li>500 k</li> <li>1 M</li> <li>2 M</li> </ul>	<ul style="list-style-type: none"> <li>104</li> <li>204</li> <li>504</li> <li>105</li> <li>205</li> </ul>	<ul style="list-style-type: none"> <li>200</li> <li>200</li> <li>200</li> <li>200</li> <li>200</li> </ul>	<ul style="list-style-type: none"> <li>2.00</li> <li>1.00</li> <li>0.40</li> <li>0.20</li> <li>0.10</li> </ul>

The products indicated by ➔ mark are manufactured upon receipt of order basis.

■ **OUTLINE DIMENSIONS**

Unless otherwise specified, tolerance : ± 0.3 (Unit : mm)

● **RJ-4W, RJ-4EW**  
Top adjustment

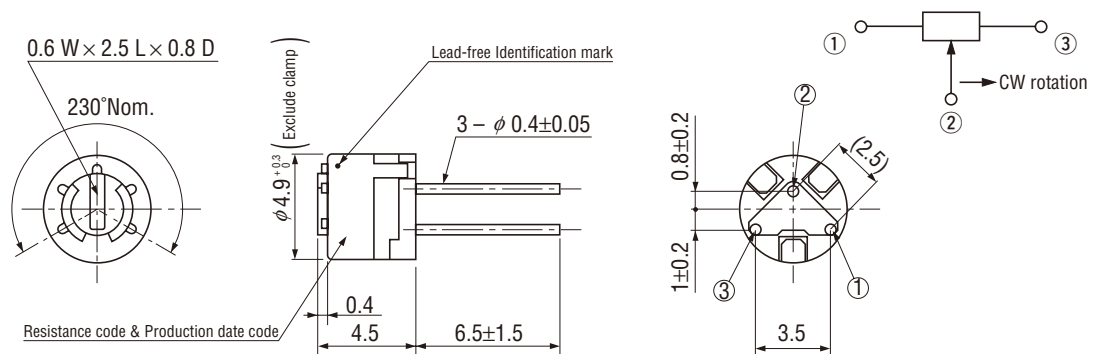

● **RJ-4WS, RJ-4EWS**  
Side adjustment

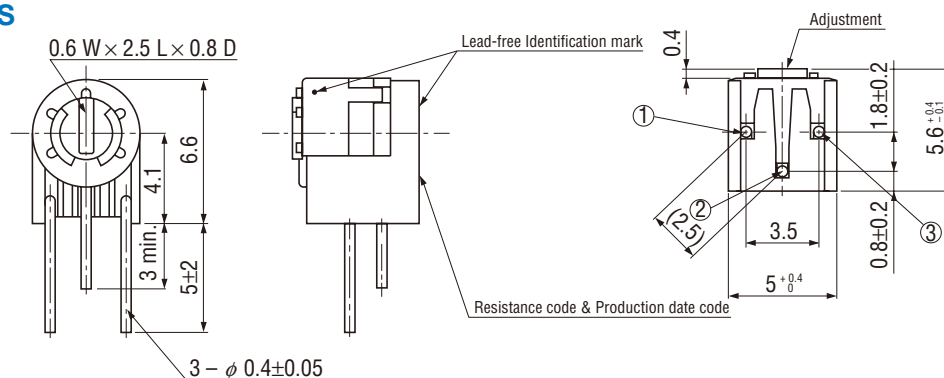

■ **PACKAGING SPECIFICATIONS**

<Vinyl bag packaging specifications>

- Unit of bulk in vinyl bag packaging is 50 pcs. per pack.
- Boxing of bulk in vinyl bags is performed with 200 pcs. per box.