

150.10 CUT-OFF, TOOLHOLDERS

Holders 150.10-..20/25 and HSS-blades 150.10A-20/25 for cut-off

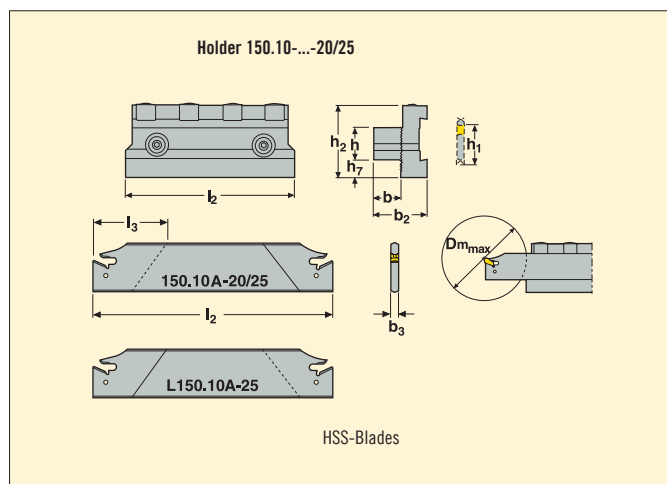

• Inserts, please see page 88-99



Part. No.	EDP	Dimensions in inch										KG	
		h	b	h ₁	h ₇	h ₂	l ₂	b ₃	b ₂	D _{m max}	l ₃		
150.10-10-20	71869	0.625	0.625	—	0.500	1.620	3.500	—	1.410	—	—	1.540	150.10-20..
150.10-12-20	71882	0.750	0.750	—	0.380	1.620	3.500	—	1.530	—	—	1.760	150.10-20..
150.10-16-20	78182	1.000	1.000	—	0.130	1.620	3.500	—	1.780	—	—	2.650	150.10-20..
150.10-16-25	71885	1.000	1.000	—	0.380	1.620	4.500	—	1.780	—	—	3.010	150.10-25..
150.10-20-25	71876	1.250	1.250	—	0.130	1.620	4.500	—	2.030	—	—	3.750	150.10-25..
150.10A-20-1.4	33042	—	—	0.843	—	—	4.720	0.047	—	1.400	0.980	0.130	150.10-1.4..
150.10A-20-2	33043	—	—	0.843	—	—	4.72	0.071	—	1.4	0.980	0.140	150.10-2..
150.10A-20-2.5	33044	—	—	0.843	—	—	4.72	0.079	—	1.4	0.980	0.150	150.10-2.5..
150.10A-20-3	33045	—	—	0.843	—	—	4.72	0.094	—	3.4	—	0.160	150.10-3..
150.10A-20-4	33046	—	—	0.843	—	—	4.72	0.134	—	4	—	0.18	150.10-4..
150.10A-20-5	33047	—	—	0.843	—	—	4.72	0.173	—	4	—	0.23	150.10-5..
150.10A-20-6	33048	—	—	0.843	—	—	4.72	0.222	—	4	—	0.3	150.10-6..
150.10A-25-1.4	33049	—	—	0.984	—	—	5.910	0.047	—	1.400	0.980	0.130	150.10-1.4..
150.10A-25-2	33050	—	—	0.984	—	—	5.91	0.071	—	1.4	0.980	0.140	150.10-2..
150.10A-25-2.5	33051	—	—	0.984	—	—	5.91	0.079	—	1.4	0.980	0.150	150.10-2.5..
150.10A-25-3	33052	—	—	0.984	—	—	5.91	0.094	—	4	—	0.160	150.10-3..
150.10A-25-4	33053	—	—	0.984	—	—	5.91	0.134	—	4.8	—	0.22	150.10-4..
150.10A-25-5	33054	—	—	0.984	—	—	5.91	0.173	—	5.6	—	0.29	150.10-5..
150.10A-25-6	33055	—	—	0.984	—	—	5.91	0.222	—	5.6	—	0.37	150.10-6..
L150.10A-25-1.4	33057	—	—	0.984	—	—	5.91	0.047	—	1.4	0.980	0.13	150.10-1.4..

SPARE PARTS, PARTS INCLUDED IN DELIVERY

Toolholder/ Insert Dimension	Wedge	Wedge Screw	Screw/Key		Key for insert *
-20					
-25	150.10-646	150.10-650	MF6S 6x25	150.10-159	150.10A-150
	150.10-646	150.10-650	MF6S 6x25	150.10-159	150.10A-150

* To be ordered separately